

**Serie | 4, Fully-integrated dishwasher,  
60 cm  
SMV46MX00G**



**A++**



**Gentle - even to your ear. Our SilencePlus.**

- **ExtraDry:** extra drying option for difficult-to-dry loads.
- **Silence Plus:** pleasantly quiet at 46 dB.
- **Glass 40°C:** protective programme for gently cleaning and drying glasses.
- **VarioFlex-baskets and VarioDrawer:** enhanced flexibility options with more space on all levels.
- **VarioDrawer:** 3rd level loading for cutlery and smaller kitchen utensils.

**Technical Data**

Water consumption (l) :	9.5
Construction type :	Built-in
Height of removable worktop (mm) :	0
Dimensions of the product (HxWxD) :	815 x 598 x 550
Required niche size for installation (HxWxD) :	815-875 x 600 x 550
Depth with open door 90 degree (mm) :	1150
Adjustable feet :	Yes - all from front
Maximum adjustability feet (mm) :	60
Adjustable plinth :	both horizontal and vertical
Net weight (kg) :	34.312
Gross weight (kg) :	36.5
Connection rating (W) :	2400
Current (A) :	10
Voltage (V) :	220-240
Frequency (Hz) :	50; 60
Length of electrical supply cord (cm) :	175
Plug type :	GB plug
Length inlet hose (cm) :	165
Length outlet hose (cm) :	190
EAN code :	4242005035915
Number of place settings :	14
Energy efficiency rating :	A++
Energy consumption annual (kWh/annum) - NEW (2010/30/EC) :	266.00
Energy consumption (kWh) :	0.93
Power consumption in left-on mode (W) - NEW (2010/30/EC) :	0.10
Power consumption in off-mode (W) - NEW (2010/30/EC) :	0.10
Water consumption annual (l/annum) - NEW (2010/30/EC) :	2660
Drying performance :	A
Reference programme :	Eco
Total cycle time of reference programme (min) :	210
Noise level (dB(A) re 1 pW) :	46
Installation type :	Full-integrated

**Optional accessories**

- SGZ1010 :
- SMZ5003 :
- SMZ5005 :
- SMZ5035 : Decor conversion kit, stainless steel
- SMZ5300 :



## Serie | 4, Fully-integrated dishwasher, 60 cm SMV46MX00G

### Gentle - even to your ear. Our SilencePlus.

#### Performance

- Energy Efficiency Class: A++
- Capacity: 14 place settings. VarioDrawer on 3rd level
- Energy consumption in programme Eco 50 °C: 266 kWh per year, based on 280 standard cleaning cycles using cold water fill and the consumption of the low power modes. Actual energy consumption will depend on how the appliance is used.
- Water consumption in Eco 50 programme: 2660 litres per year, based on 280 standard cleaning cycles
- Programme time in Eco 50 programme: 210 minutes
- A rated performance for washing and A for drying
- Noise level dB (A) re 1pW: 46 dB
- Noise level (silence programme): not available(A) re 1 pW
- Energy consumption in Eco 50 programme: 0.93 kWh
- Water consumption in Eco 50 programme: 9.5 litres

#### Programmes/functions

- 6 programmes: Intensive 70 °C, Auto 45-65 °C, Eco 50 °C, Glass 40 °C, 1 hour 65 °C, Quick 45 °C
- 3 special options: VarioSpeed Plus, Hygiene Plus, Extra Dry
- Special program 1: Machine Care
- 5 temperatures

#### Flexible design elements

- VarioFlex baskets
- VarioDrawer - loading of cutlery on 3rd level
- 3 stage Rackmatic height-adjustable top basket
- Lower rack handle: BO plastic-middle grey-red
- 2 foldable plate racks in top basket
- 4 foldable plate racks in bottom basket
- Upper rack cup shelf

#### Innovations and technology

- Heat exchanger - Hygienic and efficient drying
- DosageAssist detergent dispenser
- Automatic detergent detection
- ActiveWater hydraulic water system
- EcoSilence BLDC drive
- AquaSensor III, Load Sensor
- AquaMix - Glass protection system
- AquaStop: Bosch warranty in case of water damage - for the lifetime of the appliance. Please find warranty terms under <https://www.bosch-home.co.uk/customer-service/care-protection-and-parts/additional-warranties>
- Curved spray arms - Optimum water distribution

#### Design features

- Push button top edge controls
- Acoustic end of cycle indicator, Time remaining indicator (min), water inlet indicator
- Red Info light, Acoustic end of cycle indicator, Time remaining indicator (min), water inlet indicator
- Time delay (3, 6 or 24 hours)
- Child safety - Childproof door lock
- Stainless steel interior
- Display colour: Red LED indicators
- LED salt refill indicator, LED rinse aid refill indicator
- Alternating spray arms
- Large item spray head, steam protection plate
- Self-cleaning filter system with 3 piece corrugated filter
- Acoustic end of cycle indicator
- Front-adjustable rear foot
- Dimensions (HxWxD): 81.5 x 59.8 x 55cm
- Efficiency information relates to the Eco 50 programme. This programme is suitable for cleaning normally soiled tableware and is the most efficient programme in terms of combined energy and water consumption.

**Serie | 4, Fully-integrated dishwasher, 60 cm  
SMV46MX00G**

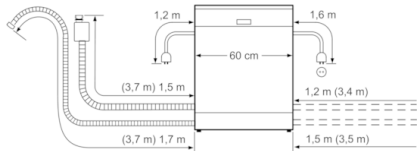

( ) Werte mit Verlängerungssatz

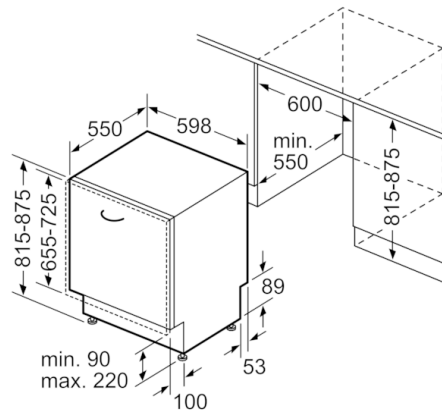

measurements in mm