

Series 2, Fully-integrated dishwasher, 60 cm SMV24AX01G



A+



Optional accessories

SGZ1010	inlet and outlet hose extension
SMZ2056	Attachment door, stainless steel
SMZ5000	Dishwashing aid set
SMZ5001	Baby care kit
SMZ5002	Silver polishing cassette
SMZ5003	Retractable hinge f. high corpus dimens.
SMZ5006	decorative strips 81cm st.steel

Silent operation in the background of your home.

- **ExtraDry:** extra drying option for difficult-to-dry loads.
- **InfoLight:** a red light on the floor indicates whether the dishwasher is switched on or off.
- **AquaStop:** Bosch's warranty in case of water damage – throughout the lifetime of the appliance.*
- **EcoSilence Drive:** especially energy-saving and silent in operation with a particularly high life span.
- **10-year guarantee:** our convincing promise of quality against rusting of the inner tub.

Technical Data

Maximum number of place settings: 12
The water consumption of the eco programme in liters per cycle:	11.7 l
Built-in / Free-standing: Built-in
Height of removable worktop: 0 mm
Dimensions of the product (HxWxD):815 x 598 x 550 mm
Min. required niche size for installation (HxWxD):815-875 x 600 x 550 mm
Depth with open door 90 degree: 1150 mm
Adjustable feet: Yes - all from front
Maximum adjustability feet: 60 mm
Adjustable plinth: Both horizontal and vertical
Net weight: 29.3 kg
Gross weight: 31.1 kg
Connection rating: 2400 W
Fuse protection: 10 A
Voltage: 220-240 V
Frequency: 60; 50 Hz
Length electrical supply cord: 175.0 cm
Plug type: GB plug
Length inlet hose: 165 cm
Length outlet hose: 190 cm
EAN code: 4242005027927
Installation typology: Integrated



Series 2, Fully-integrated dishwasher, 60 cm SMV24AX01G

Silent operation in the background of your home.

Performance

- Capacity: 12 place settings
- Energy consumption in programme Eco 50 °C: 290 kWhper year, based on 280 standard cleaning cycles using cold water fill and the consumption of the low power modes. Actual energy consumption will depend on how the appliance is used.
- Water consumption in Eco50 programme: 3300 litres per year, based on 280 standard cleaning cycles
- Programme time in Eco 50 programme: 210 minutes
- Noise level dB (A) re 1pW: 52 dB
- Energy consumption in Eco 50 programme: 1.02 kWh

Programmes/functions

- 4 programmes: Intensive 70 °C, Normal
- 65 °C, Eco 50 °C, Quick wash
- 1 special option: Extra Dry
- 4 temperatures

Flexible design elements

- Normal baskets
- Upper rack cup shelf
- Cutlery basket in lower rack

Innovations and technology

- Heat exchanger.
- DosageAssist detergent dispenser
- Automatic detergent detection
- ActiveWater hydraulic water system
- EcoSilence BLDC drive
- Load Sensor
- AquaMix - Glass protection system
- AquaStop: Bosch's warranty in case of water damage - for the lifetime of the appliance. Please find warranty terms under <https://www.bosch-home.co.uk/customer-service/care-protection-and-parts/additional-warranties>
- Curved spray arms - Optimum water distribution

Design features

- Push button top edge controls
- Acoustic end of cycle indicator, water inlet indicator
- Red Info light, Acoustic end of cycle indicator, Washing + drying LEDs, water inlet indicator
- Stainless steel/Polinox interior
- Display colour: Red LED indicators
- LED salt refill indicator, LED rinse aid refill indicator
- Alternating spray arms
- Large item spray head, steam protection plate
- Self cleaning filter system with 3 piece corrugated filter
- Acoustic end of cycle indicator
- Front-adjustable rear foot
- Dimensions (HxWxD): 81.5 x 59.8 x 55cm

- Efficiency information relates to the Eco50 programme. This programme is suitable for cleaning normally soiled tableware and is the most efficient programme in terms of combined energy and water consumption.

**Series 2, Fully-integrated
dishwasher, 60 cm
SMV24AX01G**

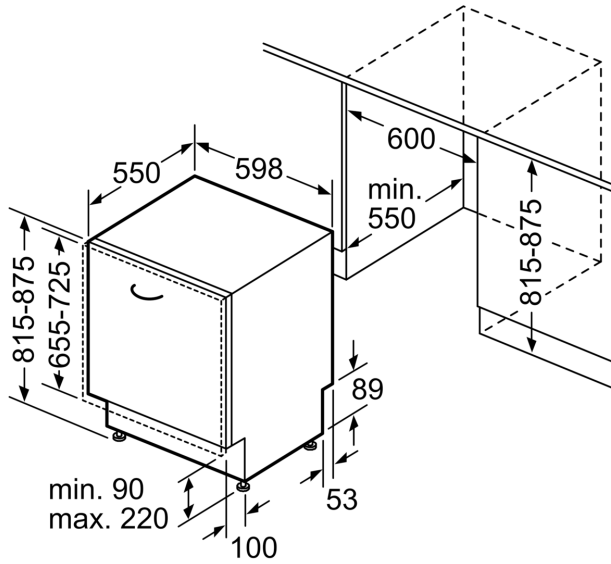

measurements in mm