

**Series 6, Built-under fridge, 82 x 60 cm, flat hinge
KUR15AFF0G**



Included accessories

1 x egg tray

**The built-under refrigerator with MultiBox:
ideal storage location for your fresh fruits
and vegetables.**

- LED lights bring a completely new lighting concept to fridges
- The egg rack keeps your eggs safe

Technical Data

Energy Efficiency Class: F

Average annual energy consumption in kilowatt hour per year (kWh/a): 114 kWh/a

Sum of volume of frozen compartments: 0 l

Sum of volume of chill compartments: 137 l

Airborne acoustical noise emissions : 38 dB(A) re 1 pW

Airborne acoustical noise emission class: C

Construction type: Built-in

Door panel options: Possible but accessory

Height: 820 mm

Width of the appliance: 598 mm

Depth of the product: 548 mm

Min. required niche size for installation (HxWxD): 820 x 600 x 550 mm

Net weight: 34.0 kg

Connection rating: 90 W

Fuse protection: 13 A

Door hinge: Right reversible

Voltage: 220-240 V

Frequency: 50 Hz

Length of electrical supply cord: 230.0 cm

Number of compressors: 1

Number of independent cooling systems: 1

Interior ventilator: No

Reversible Door Hinge: Yes

Number of Adjustable Shelves in fridge compartment (Stck): 3

Shelves for Bottles: No

EAN code: 4242005142859

Brand: Bosch

Product name / Commercial code: KUR15AFF0G

Product category: Refrigerator

Frost free system: No

Installation type: Built-under

Included accessories: 1 x egg tray



Series 6, Built-under fridge, 82 x 60 cm, flat hinge KUR15AFF0G

The built-under refrigerator with MultiBox: ideal storage location for your fresh fruits and vegetables.

Performance and Consumption

- EU19_EEK_D: F
- Total Volume : 137 l
- Annual Energy Consumption: 114 kWh/a
- Climate Class: SN-ST
- EU19_Fast freezer facility_D
- Noise Level : 38 dB , EU19_Noise emission class_D: C

-
- Fully integrated

Functions

- Ventilation through plinth
- Easy clean interior

Design features

- Mechanical control
- 1 compressor
- Automatic defrost fridge

Design features

- 3 safety glass shelves in fridge compartment of which 3 are height adjustable
- 1 removable door storage compartments.
- Bottle holder in x-deep door tray
- Bright interior LED fridge light

Freshness System

Key features - Fridge section

- Right hinged door, door reversible
- Connection value 90 W
- 220 - 240 V

Dimension and installation

- Niche Dimensions: 82 cm H x 60 cm W x 55 cm D
- Dimensions: 82 cm H x 59.8 cm W x 54.8 cm D

Key features - Freezer section

- KUR15AFF0G

Country Specific Options

- Based on the results of the standard 24-hour test. Actual consumption depends on usage/position of the appliance.

Additional features

Series 6, Built-under fridge, 82 x 60 cm, flat hinge KUR15AFF0G

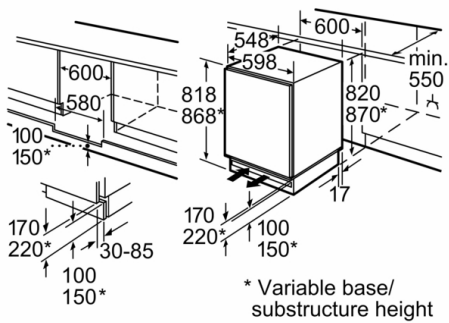

Space for electrical connection next to the appliance on the left or right-hand side.
Ventilation space in the base.

Measurements in mm

measurements in mm
Recommended gap dimensions for flat hinges

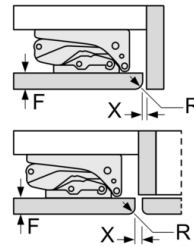

F	R	X
16-19	0-3	2.5
20	0-1	3
	2-3	2.5
21	0-1	3
	2-3	2.5
22	0	4
	1	3.5
	2-3	3

The gap dimensions recommended in the table must be adhered to in order to ensure that appliance doors do not collide with anything when they are opened, and to avoid causing damage to kitchen units.

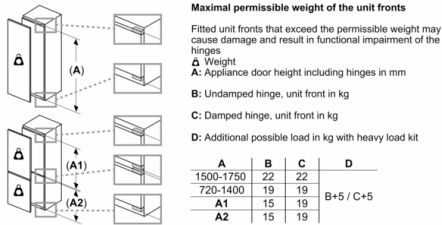

Maximal permissible weight of the unit fronts

Fitted unit fronts that exceed the permissible weight may cause damage and result in functional impairment of the hinges

Δ Weight

A: Appliance door height including hinges in mm

B: Undamped hinge, unit front in kg

C: Damped hinge, unit front in kg

D: Additional possible load in kg with heavy load kit

A	B	C	D
1500-1750	22	22	B+5 / C+5
720-1400	19	19	
A1	15	19	
A2	15	19	