

**Serie | 4, Built-in fridge-freezer with freezer at bottom, 177.2 x 54.1 cm, flat hinge
KIV87VF30G**



A++

The bottom freezer with electronic temperature control and MultiBox: set the temperature easily and precisely.

- LED lights bring a completely new lighting concept to fridges
- **VarioZone:** more flexibility due to variable-use glass shelves and drawers in the freezer compartment.
- **BigBox frozen food drawer:** for stacking storage containers or for large frozen food items.
- **LowFrost:** defrost less often thanks to lower ice formation - saves work and is energy-efficient.
- The egg rack keeps your eggs safe

Technical Data

Construction type : Built-in
 Door panel options : Not possible
 Width of the appliance : 541 mm
 Depth of the product : 545 mm
 Required niche size for installation (HxWxD) : 1775.0 x 560 x 550 mm
 Net weight : 64.115 kg
 Connection rating : 90 W
 Fuse protection : 13 A
 Door hinge : Right reversible
 Voltage : 220-240 V
 Frequency : 50 Hz
 Approval certificates : CE, VDE
 Length of electrical supply cord : 230 cm
 Storage Period in Event of Power Failure (h) : 26 h
 Number of compressors : 1
 Number of independent cooling systems : 1
 Interior ventilator : No
 Reversible Door Hinge : Yes
 Number of Adjustable Shelves in fridge compartment (Stck) : 4
 Shelves for Bottles : No
 EAN code : 4242002839370
 Brand : Bosch
 Product name / Commercial code : KIV87VF30G
 Energy consumption annual - NEW (2010/30/EC) : 227.00 kWh/annum
 Refrigerator Net capacity - NEW (2010/30/EC) : 209 l
 Freezer Net capacity - NEW (2010/30/EC) : 63 l
 Frost free system : No
 Freezing capacity) - NEW (2010/30/EC) : 3 kg/24h
 Climate class : SN-T
 Noise level : 38 dB(A) re 1 pW
 Installation type : Full-integrated

Included accessories

2 x cold accumulator
 2 x egg tray
 1 x ice cube tray

Optional accessories

KSZ10020 : Bottle Rack



4 242002 839370

Serie | 4, Built-in fridge-freezer with freezer at bottom, 177.2 x 54.1 cm, flat hinge KIV87VF30G

The bottom freezer with electronic temperature control and MultiBox: set the temperature easily and precisely.

Dimension and installation

- Easy Installation
- Height adjustable front feet
- Niche Dimensions: 177.5 cm H x 56 cm W x 55 cm D
- Dimensions: 177.2 cm H x 54.1 cm W x 54.5 cm D

Performance and Consumption

- Energy Efficiency Class: A++
- Energy Efficiency Class: A++ kWh/yr: 0.621 kWh
- Total net capacity: 272 l litres
- Net fridge capacity: 209 litres
- Net freezer capacity: 63 litres
- Noise level dB(A) re 1 pW: 38
- Climate class SN-T (suitable for ambient temperatures between 10 to 43°C)

Design features

- Bright interior LED fridge light
- Right hinged door, door reversible
- 1 compressor
- Bright interior LED fridge light
- LED electronic control
- Removable magnetic door seals - easy to clean
- Easy clean interior

Food freshness system

- FreshSense - Constant temperature control by intelligent sensor technology
- 2 x cold accumulator, 3 x egg tray, 1 x ice cube tray
- 1 MultiBox - Transparent drawer with a rippled bottom, ideal for storing fruits and vegetables.

Key features - Fridge section

- 5 door bins
- 5 removable safety glass shelves of which 4 are easy pull out
- Door shelves in fridge door: 1 large and 4 small.
- 5 safety glass shelves in fridge compartment of which 4 are height adjustable

Key features - Freezer section

- 2 transparent freezer drawers, including 1 BigBox
- Freezing capacity in 24 hours: 3 kg
- 4 star freezer rating
- Manual defrost freezer
- SuperFreezing function with automatic deactivation
- Maximum freezer storage time in power failure: 26 hours
- Calendar frozen food

Functions

Serie | 4, Built-in fridge-freezer with freezer at bottom, 177.2 x 54.1 cm, flat hinge KIV87VF30G

measurements in mm
Recommended gap dimensions for flat hinges

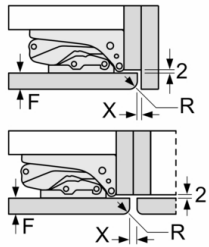

F	R	X
16-19	0-3	2.5
20	0-1	3
	2-3	2.5
21	0-1	3
	2-3	2.5
22	0	4
	1	3.5
	2-3	3

The gap dimensions recommended in the table must be adhered to in order to ensure that appliance doors do not collide with anything when they are opened, and to avoid causing damage to kitchen units.

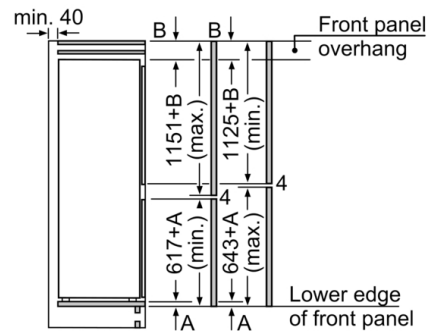

The specified unit door dimensions are valid for a door gap of 4 mm.

measurements in mm

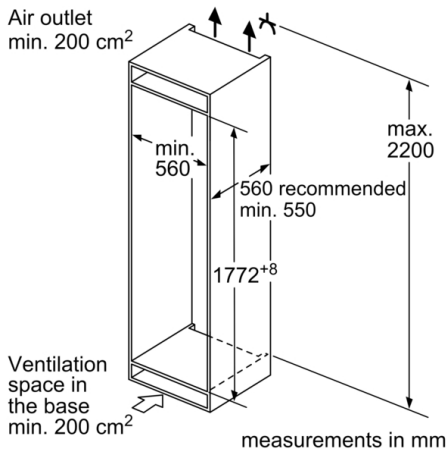

measurements in mm

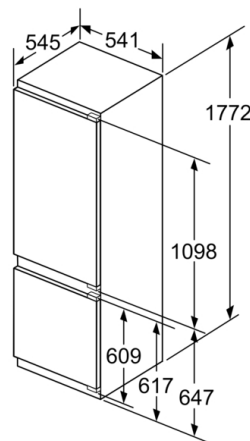

measurements in mm