

**Serie | 4, Built-in fridge-freezer with freezer at bottom, 177.2 x 54.1 cm, sliding hinge
KIV86VSF0G**



Included accessories

3 x egg tray
1 x ice cube tray

Optional accessories

KSZ10020 : Bottle Rack



The bottom freezer with electronic temperature control and MultiBox: set the temperature easily and precisely.

- LED lights bring a completely new lighting concept to fridges
- **VarioZone:** more flexibility due to variable-use glass shelves and drawers in the freezer compartment.
- **BigBox frozen food drawer:** for stacking storage containers or for large frozen food items.
- **LowFrost:** defrost less often thanks to lower ice formation - saves work and is energy-efficient.
- The egg rack keeps your eggs safe

Technical Data

Energy Efficiency Class: F

Average annual energy consumption in kilowatt hour per year (kWh/a): 279 kWh/annum

Sum of volume of frozen compartments: 76 l

Sum of volume of chill compartments: 192 l

Airborne acoustical noise emissions : 38 dB(A) re 1 pW

Airborne acoustical noise emission class: C

Construction type: Built-in

Door panel options: Not possible

Width of the appliance: 541 mm

Depth of the product: 545 mm

Required niche size for installation (HxWxD): 1775.0 x 560 x 550 mm

Net weight: 59.7 kg

Connection rating: 90 W

Fuse protection: 13 A

Door hinge: Right reversible

Voltage: 220-240 V

Frequency: 50 Hz

Approval certificates: CE, VDE

Length of electrical supply cord: 230 cm

Storage Period in Event of Power Failure (h): 9 h

Number of compressors: 1

Number of independent cooling systems: 1

Interior ventilator: No

Reversible Door Hinge: Yes

Number of Adjustable Shelves in fridge compartment (Stck): 3

Shelves for Bottles: No

Frost free system: No

Installation type: Full-integrated

Type of hinge: Follow-door



Serie | 4, Built-in fridge-freezer with freezer at bottom, 177.2 x 54.1 cm, sliding hinge KIV86VSF0G

The bottom freezer with electronic temperature control and MultiBox: set the temperature easily and precisely.

Performance and Consumption

- EU19_EEK_D: F
- Total Volume : 268 l
- Net Fridge Volume : 192 l
- Net Freezer Volume : 76 l
- Freezing capacity 24h : 4 kg
- Annual Energy Consumption: 279 kWh/a
- Climate Class: SN-ST
- Noise Level : 38 dB , EU19_Noise emission class_D: C
- Temperature rise time : EU19_Temperature rise time_D: 9 H

Functions

- Sliding hinge
- Sliding hinge
- Easy clean interior

Design features

- LED electronic control
- SuperFreezing function with automatic deactivation
- Automatic defrost fridge

Design features

- 4 safety glass shelves in fridge compartment of which 3 are height adjustable
- 1 removable door storage compartments.
- Bright interior LED fridge light

Freshness System

- 1 MultiBox - Transparent drawer with a rippled bottom, ideal for storing fruits and vegetables.

Food freshness system

- 3 transparent freezer drawers, including 1 BigBox

Key features - Fridge section

- Right hinged door, door reversible
- Connection value 90 W
- 220 - 240 V

Dimension and installation

- Niche Dimensions: 177.5 cm H x 56 cm W x 55 cm D
- Dimensions: 177.2 cm H x 54.1 cm W x 54.5 cm D

Key features - Freezer section

- 3 x egg tray, 1 x ice cube tray

Design features

Dimension and installation

Country Specific Options

- Based on the results of the standard 24-hour test. Actual consumption depends on usage/position of the appliance.

Additional features

Serie | 4, Built-in fridge-freezer with freezer at bottom, 177.2 x 54.1 cm, sliding hinge KIV86VSF0G

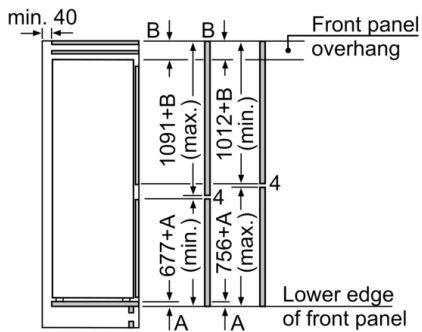
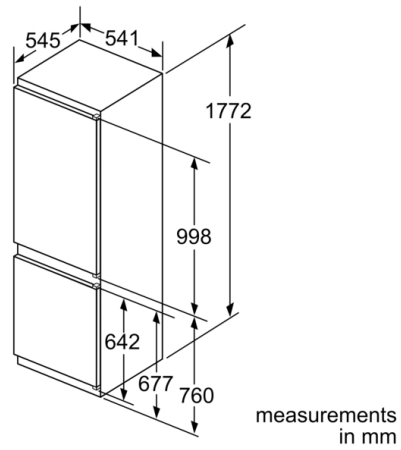
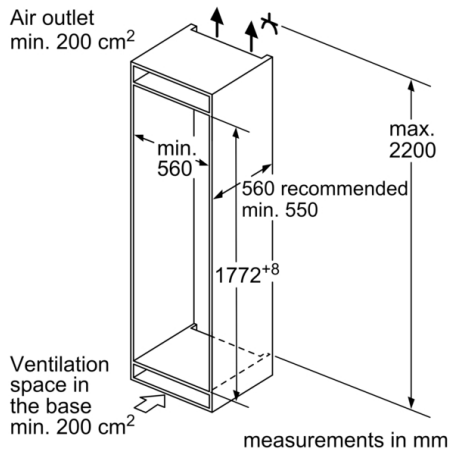

The specified unit door dimensions are valid for a door gap of 4 mm.
measurements in mm