

**Series 2, Built-in fridge-freezer with freezer at bottom, 193.5 x 54.1 cm, sliding hinge
KIN96NSE0**



KSZB6R00 Bottle Rack
KSZGGM00 Butter box

The extra large built-in fridge freezer with 12% more cooling volume including Multi Box XXL drawer for fruit and vegetables, No Frost and error warning signal for optimal storage.

- **Built-in XL:** get 11% extra volume of storage thanks to a taller design.
- **NoFrost:** never defrost again, thanks to perfect protection from ice formation - that saves time and effort.
- **An audible alarm system signals the door is open**
- **LED lighting:** all your items in perfect view.
- **Two cooling systems:** separately controllable fridge and freezer compartments

Energy Efficiency Class: E
 Average annual energy consumption in kilowatt hour per year (kWh/a): 231 kWh/annum
 Sum of volume of frozen compartments: 75 l
 Sum of volume of chill compartments: 215 l
 Airborne acoustical noise emissions : 34 dB(A) re 1 pW
 Airborne acoustical noise emission class: B
 Built-in / Free-standing: Built-in
 Door panel options: Not possible
 Height: 1935 mm
 Width of the appliance: 541 mm
 Depth: 548 mm
 Min. required niche size for installation (HxWxD): .. 1940 x 560 x 550 mm
 Net weight: 54.9 kg
 Fuse protection: 10 A
 Door hinge: Right reversible
 Voltage: 220-240 V
 Frequency: 50 Hz
 Length electrical supply cord: 230.0 cm
 Number of compressors: 1
 Number of independent cooling systems: 2
 Interior ventilator: No
 Reversible Door Hinge: Yes
 Number of Adjustable Shelves in fridge compartment: 4
 Shelves for Bottles: No
 Frost free system: Freezer
 Installation typology: Integrated



Series 2, Built-in fridge-freezer with freezer at bottom, 193.5 x 54.1 cm, sliding hinge KIN96NSE0

- Niche Dimensions: 194 cm H x 56 cm W x 55 cm D
- Length of power cord: 230 cm

Country Specific Options

The extra large built-in fridge freezer with 12% more cooling volume including Multi Box XXL drawer for fruit and vegetables, No Frost and error warning signal for optimal storage.

Design features

- Built-in fridge-freezer
- Right hinged door, door reversible
- Height adjustable front feet
- Bright interior LED fridge light in fridge section
- Separate, electronic temperature control with LED display

Functions

- Automatic defrost fridge
- NO_FROST_NEU_BL, never have to defrost ever again
- Two separate cooling circuits allow independent temperature control and prevents the transference of humidity between the fridge and freezer cavity
- Super Cooling: automatic deactivation
- Optical and accoustical

Food freshness system

- 1 MultiBox - Transparent drawer with a rippled bottom, ideal for storing fruits and vegetables.

Key features - Fridge section

- 5 safety glass shelves in fridge compartment of which 4 are height adjustable
- Door shelves in fridge door: 1 large and 3 small.

Key features - Freezer section

- 3 freezer drawers

Additional features

- 3 x egg tray, 1 x ice cube tray

Performance and Consumption

- Climate Class: SN-ST
- Total Volume : 290 l
- Net Fridge Volume : 215 l
- Net Freezer Volume : 75 l
- Annual Energy Consumption: 231 kWh/a
- Noise Level : 34 dB , EU19_Noise emission class_D: B
- Temperature rise time : EU19_Temperature rise time_D: 10 H
- Freezing capacity 24h : 7.5 kg
- 220 - 240 V
- EU19_EEK_D: E
- EU19_Fast freezer facility_D
- Based on the results of the standard 24-hour test. Actual consumption depends on usage/position of the appliance.

Dimension and installation

- Dimensions: 193.5 cm H x 54.1 cm W x 54.8 cm D

**Series 2, Built-in fridge-freezer with
freezer at bottom, 193.5 x 54.1 cm,
sliding hinge
KIN96NSE0**

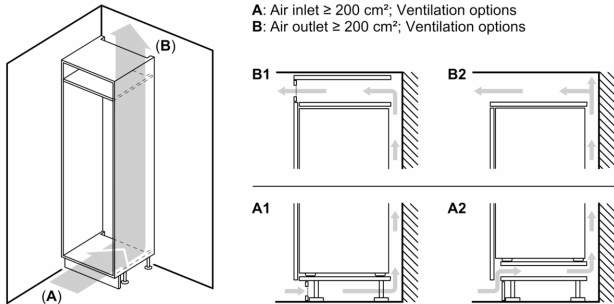

Measurements in mm

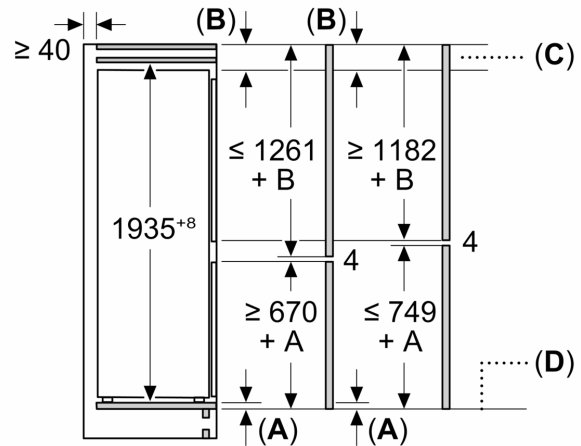

C: Front panel overhang

D: Lower edge of front panel

Measurements in mm

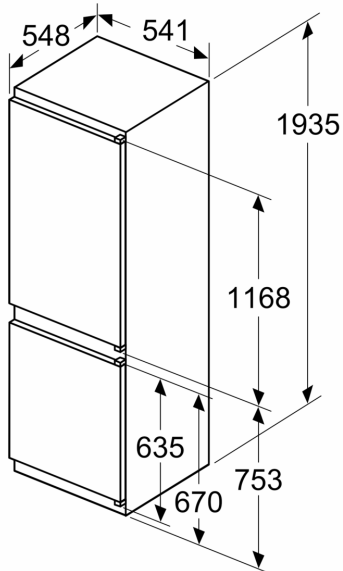

Measurements in mm

