

**Serie | 4, Built-in fridge-freezer with freezer at bottom, 177.2 x 54.1 cm, flat hinge
KIN86VF30G**



A++

The bottom freezer with MultiBox and electronic temperature control: set the temperature easily and precisely.

- LED lights bring a completely new lighting concept to fridges
- **VarioZone:** more flexibility due to variable-use glass shelves and drawers in the freezer compartment.
- **BigBox frozen food drawer:** for stacking storage containers or for large frozen food items.
- Temperature sensors continually monitor the temperature inside and outside the built-in fridge.
- An audible alarm system signals the door is open

Technical Data

Construction type : Built-in
 Door panel options : Not possible
 Width of the appliance : 541 mm
 Depth of the product : 545 mm
 Required niche size for installation (HxWxD) : 1775.0 x 560 x 550 mm
 Net weight : 64.605 kg
 Connection rating : 90 W
 Fuse protection : 13 A
 Door hinge : Right reversible
 Voltage : 220-240 V
 Frequency : 50 Hz
 Approval certificates : CE, VDE
 Length of electrical supply cord : 230 cm
 Storage Period in Event of Power Failure (h) : 13 h
 Number of compressors : 1
 Number of independent cooling systems : 1
 Interior ventilator : No
 Reversible Door Hinge : Yes
 Number of Adjustable Shelves in fridge compartment (Stck) : 3
 Shelves for Bottles : No
 EAN code : 4242002839578
 Brand : Bosch
 Product name / Commercial code : KIN86VF30G
 Energy consumption annual - NEW (2010/30/EC) : 222.00 kWh/annum
 Refrigerator Net capacity - NEW (2010/30/EC) : 188 l
 Freezer Net capacity - NEW (2010/30/EC) : 67 l
 Frost free system : Freezer
 Freezing capacity) - NEW (2010/30/EC) : 8 kg/24h
 Climate class : SN-ST
 Noise level : 39 dB(A) re 1 pW
 Installation type : Full-integrated

Included accessories

2 x cold accumulator
 2 x egg tray
 1 x ice cube tray

Optional accessories

KSZ10020 : Bottle Rack



4 242002 839578

Serie | 4, Built-in fridge-freezer with freezer at bottom, 177.2 x 54.1 cm, flat hinge KIN86VF30G

The bottom freezer with MultiBox and electronic temperature control: set the temperature easily and precisely.

Performance and Consumption

- Energy Efficiency Class: A++
- Energy consumption: 222 kWh kWh/yr.
- Total net capacity: 255 l litres
- Net fridge capacity: 188 litres
- Net freezer capacity: 67 litres
- Noise level dB(A) re 1 pW: 39
- Climate class SN-ST (suitable for ambient temperatures between 10 to 38°C)

Design features

- Electronic LED display
- Bright interior LED fridge light
- Right hinged door, door reversible
- 1 compressor

Food freshness system

- FreshSense - Constant temperature control by intelligent sensor technology
- 1 MultiBox - Transparent drawer with a rippled bottom, ideal for storing fruits and vegetables.
- 2 x cold accumulator, 3 x egg tray, 1 x ice cube tray

Key features - Fridge section

- 4 door bins

Key features - Freezer section

- NoFrost freezer, never have to defrost ever again
- 3 transparent freezer drawers, including 1 BigBox
- Freezing capacity in 24 hours: 8 kg
- Maximum freezer storage time in power failure: 13 hours
- Calendar frozen food

Functions

- SuperFreezing function with automatic deactivation

Dimension and installation

- Dimensions: 177.2 cm H x 54.1 cm W x 54.5 cm D
- Niche Dimensions: 177.5 cm H x 56 cm W x 55 cm D
- 220 - 240 V

Serie | 4, Built-in fridge-freezer with freezer at bottom, 177.2 x 54.1 cm, flat hinge KIN86VF30G

measurements in mm
Recommended gap dimensions for flat hinges

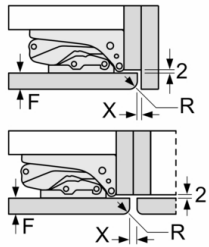

F	R	X
16-19	0-3	2.5
20	0-1	3
	2-3	2.5
21	0-1	3
	2-3	2.5
22	0	4
	1	3.5
	2-3	3

The gap dimensions recommended in the table must be adhered to in order to ensure that appliance doors do not collide with anything when they are opened, and to avoid causing damage to kitchen units.

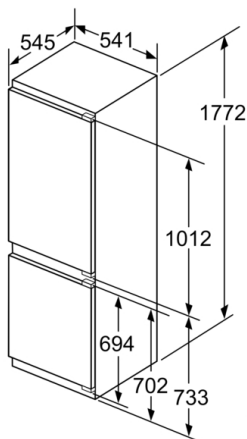
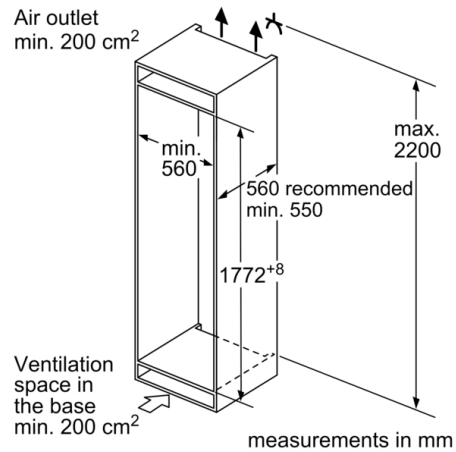

measurements in mm

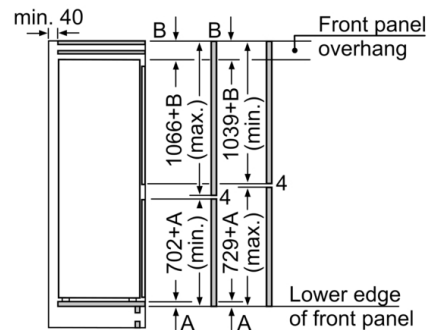

The specified unit door dimensions are valid for a door gap of 4 mm.
measurements in mm