

**Series 6, Built-in fridge-freezer with freezer at bottom, 177.2 x 55.8 cm, soft close flat hinge KIN86ADD0**



**Optional accessories**

KSZGGM00 Butter box

**The spacious built-in fridge-freezer with VitaFresh XXL near  $<0^{\circ}>$ , No Frost and constant temperature level keeps your food fresh for longer.**

- **VitaFresh XXL Pro near  $0^{\circ}\text{C}$ :** climate-controlled compartments lock in freshness and nutrients for longer.
- **NoFrost:** never defrost again, thanks to perfect protection from ice formation - that saves time and effort.
- **Eco Airflow:** maintains optimal air circulation and a constant temperature level throughout the cooling area.
- **Two cooling systems:** separately controllable fridge and freezer compartments
- **High-stability door trays:** more height means more flexible space and stability.

**Technical Data**

Energy Efficiency Class: .....	D
Average annual energy consumption in kilowatt hour per year (kWh/a): .....	186 kWh/annum
Sum of volume of frozen compartments: .....	76 l
Sum of volume of chill compartments: .....	184 l
Airborne acoustical noise emissions : .....	35 dB(A) re 1 pW
Airborne acoustical noise emission class: .....	B
Built-in / Free-standing: .....	Built-in
Door panel options: .....	Possible but accessory
Height: .....	1772 mm
Width of the appliance: .....	558 mm
Depth: .....	548 mm
Min. required niche size for installation (HxWxD): 1775.0 x 560 x 550 mm	
Net weight: .....	58.2 kg
Fuse protection: .....	10 A
Door hinge: .....	Right reversible
Voltage: .....	220-240 V
Frequency: .....	50 Hz
Length electrical supply cord: .....	230.0 cm
Number of compressors: .....	1
Number of independent cooling systems: .....	2
Interior ventilator: .....	No
Reversible Door Hinge: .....	Yes
Number of Adjustable Shelves in fridge compartment: .....	2
Shelves for Bottles: .....	Yes
Frost free system: .....	Freezer
Installation typology: .....	Integrated



## **Series 6, Built-in fridge-freezer with freezer at bottom, 177.2 x 55.8 cm, soft close flat hinge KIN86ADD0**

**The spacious built-in fridge-freezer with VitaFresh XXL near <math>0^{\circ}</math>, No Frost and constant temperature level keeps your food fresh for longer.**

- Built-in fridge-freezer
- easy Installation
- Fixed hinge, SoftClosing Door - dampens door movement, for smooth and effortless closure

### **Performance and Consumption**

- EU19\_EEK\_D: D
- Total Volume : 260 l
- Annual Energy Consumption: 186 kWh/a
- Noise Level : 35 dB , EU19\_Noise emission class\_D: B

### **Functions**

- Bright interior LED fridge light in fridge section

### **Design features**

- NO\_FROST\_NEU\_BL, never have to defrost ever again
- Separate, electronic temperature control with LED display
- Super Cooling: automatic deactivation
- Two separate cooling circuits allow independent temperature control and prevents the transference of humidity between the fridge and freezer cavity
- Optical and accoustical
- EU19\_Fast freezer facility\_D
- VarioZone - adaptable storage for more flexibility

### **Design features**

- Net Fridge Volume : 184 l
- 4 safety glass shelves in fridge compartment of which 2 are height adjustable
- 1 removable door storage compartments.
- Metal bottle rack
- Door shelves in fridge door: 1 large and 1 small.
- 3 door trays, including 1x dairy compartment

### **Freshness System**

- 1 VitaFresh drawer with humidity control - Fruits and vegetables retain vitamins and stay fresh for longer

### **Food freshness system**

- Net Freezer Volume : 76 l
- Freezing capacity 24h : 8 kg
- SuperFreeze function with automatic deactivation
- Temperature rise time : EU19\_Temperature rise time\_D: 11 H
- 3 freezer drawers

### **Dimension and installation**

- Dimensions: 177.2 cm H x 55.8 cm W x 54.8 cm D
- Niche Dimensions: 177.5 cm H x 56 cm W x 55 cm D

### **Key features - Fridge section**

- Right hinged door, door reversible
- Height adjustable front feet
- Climate Class: SN-ST
- 220 - 240 V
- Length of power cord: 230 cm

### **Key features - Freezer section**



- 3 x egg tray, 1 x ice cube tray

**Country Specific Options**

- Based on the results of the standard 24-hour test. Actual consumption depends on usage/position of the appliance.

**Series 6, Built-in fridge-freezer with  
freezer at bottom, 177.2 x 55.8 cm,  
soft close flat hinge  
KIN86ADD0**

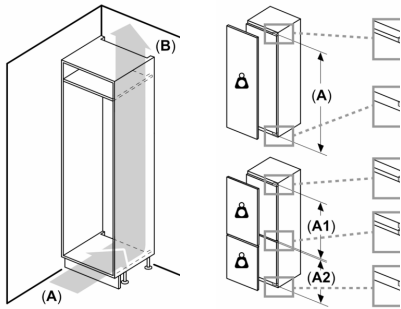

Measurement



Air outlet  
min. 200 cm<sup>2</sup>

Ventilation  
space  
in the base  
min. 200 cm<sup>2</sup>

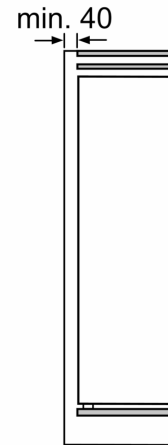

The specified  
are valid for ε

measurement  
Recommend

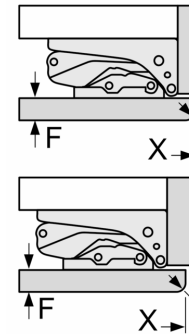

The gap dime  
in the table m  
to ensure that  
collide with ai  
and to avoid c