

Serie | 6, American side by side, 177 x 91 cm, Inox-easyclean KAG90AI20G



A+

The NoFrost side-by-side fridge-freezer with ice and water dispenser and HomeBar: provides convenient access to your drinks.

- **Ice dispenser:** dispenses ice cubes at the push of a button.
- **Extra Large size:** provides much more space for your food.
- **MultiBox:** transparent drawer with wave bottom, ideal for the storage of fruits and vegetables
- LED lights bring a completely new lighting concept to fridges
- **NoFrost:** never defrost again, thanks to perfect protection from ice formation - that saves time and effort.

Technical Data

Construction type :	Free-standing
Door panel options :	Not possible
Height (mm) :	1770
Width of the product (mm) :	910
Depth of the product :	720
Net weight (kg) :	115.400
Connection rating (W) :	374
Current (A) :	10
Door hinge :	Left & Right
Voltage (V) :	220-240
Frequency (Hz) :	50
Approval certificates :	CE
Length of electrical supply cord (cm) :	240
Storage Period in Event of Power Failure (h) :	4
Number of compressors :	1
Number of independent cooling systems :	1
Interior ventilator :	Yes
Reversible Door Hinge :	No
Number of Adjustable Shelves in fridge compartment (Stck) :	0
Shelves for Bottles :	No
Capacity of Water Tank [l] :	1.1
EAN code :	4242002816470
Brand :	Bosch
Product name / Commercial code :	KAG90AI20G
Energy consumption annual (kWh/annum) - NEW (2010/30/EC) :	432.00
Refrigerator Net capacity (l) - NEW (2010/30/EC) :	359
Freezer Net capacity (l) - NEW (2010/30/EC) :	163
Frost free system :	Fridge and freezer
Freezing capacity (kg/24h) - NEW (2010/30/EC) :	11
Climate class :	SN-T
Noise level (dB(A) re 1 pW) :	43
Installation type :	N/A

Included accessories

- 1 x connection hose
- 1 x egg tray



4 242002 816470

Serie | 6, American side by side, 177 x 91 cm, Inox-easyclean KAG90AI20G

The NoFrost side-by-side fridge-freezer with ice and water dispenser and HomeBar: provides convenient access to your drinks.

Performance

- Energy consumption: 432 kWh kWh/yr.
- Total net capacity: 522 l litres
- Net fridge capacity: 359 litres
- Net freezer capacity: 157 litres
- Noise level dB(A) re 1 pW: 43
- Climate class SN-T (suitable for ambient temperatures between 10 to 43°C)

Design features

- Homebar in the right hand door. Easy access to items in door and acts as a useful shelf
- Automatic ice cube maker
- Ice cube output: 0.9 kg/24 hours
- Internal water filter
- Aluminium Vertical door handle
- No Frost
- Automatic defrost fridge
- 1 compressor
- MultiAirflow system - improves circulation of air around the fridge
- Bright interior LED fridge light
- Removable magnetic door seals - easy to clean
- Optical and acoustical door open warning
- Freezer malfunction warning signal: optical and acoustical

Freshness System

- 2 MultiBox drawers on rails - Transparent drawers with a corrugated bottom, ideal for storing fruits and vegetables.

Additional features

- 3 safety glass shelves in fridge compartment of which 0 are height adjustable
- Freezing capacity in 24 hours: 11 kg
- Maximum freezer storage time in power failure: 4 hours
- Left hinged, Right hinged door
- Height adjustable front feet

Functions

- Electronic control for fridge and freezer with LED display
- Super Cooling: automatic deactivation
- SuperFreezing function with automatic deactivation
- Freezer malfunction warning signal: optical and acoustical warning system

Key features - Fridge section

- MultiBox - the special compartment in the door
- 2 MultiBox drawers on rails - Transparent drawers with a corrugated bottom, ideal for storing fruits and vegetables.
- 3 removable door storage compartments.
- Door shelves in fridge door: 3 large and 1 small.
- 1 x connection hose, 3 x egg tray
- Bright interior LED fridge light

Key features - Freezer section

- 2 freezer drawers
- Door trays in freezer door: 4
- To achieve the declared energy consumption, the distanceholders have to be used. As a result, the appliance depth increases by about 3.5 cm. The appliance used without the distance holder is fully functional, but has a slightly higher energy consumption.
- Connection Length (water supply):500 cm
- Dimensions: 177 cm H x 91 cm W x 72 cm D

**Serie | 6, American side by side, 177 x 91
cm, Inox-easyclean
KAG90AI20G**

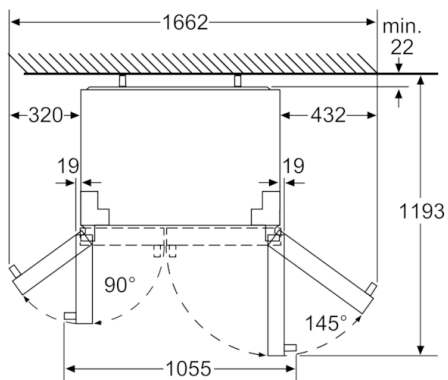
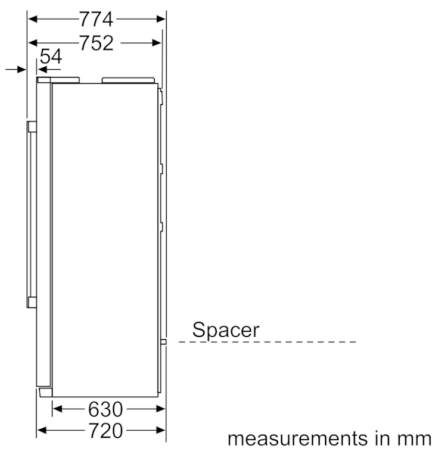

Drawers can be pulled out completely when the door is open to 145°.
measurements in mm

