

Series 2, Built-in microwave oven, 51 x 28 cm, Stainless steel HMT84G651B



A great partner for the kitchen, the built-in compact microwave defrosts, heats and cooks helping you prepare food in the kitchen.

- **Red LED display control:** easy-to-use thanks to the time functions.
- **Pop-out controls:** Make the front of the oven easy to clean and give it a sleek look.
- **White LCD display control:** easy-to-use thanks to direct access to additional functions, temperature recommendation and temperature indication.
- **Microwave Boost Function:** quick and easy warming.

Technical Data

Type of micro-wave oven: MW+Grill function
 Type of control:Electronic
 Dimensions: 280 x 513 x 405 mm
 Cavity dimensions: 215.0 x 337.0 x 354.0 mm
 Length of electrical supply cord: 130.0 cm
 Net weight: 17.7 kg
 Gross weight: 20.1 kg
 EAN code:4242002495064
 Maximum micro-wave power:900 W
 Connection rating: 1450 W
 Fuse protection:10 A
 Voltage:230 V
 Frequency: 50 Hz
 Plug type: GB plug



Series 2, Built-in microwave oven, 51 x 28 cm, Stainless steel HMT84G651B

A great partner for the kitchen, the built-in compact microwave defrosts, heats and cooks helping you prepare food in the kitchen.

Key Information

- Electronic control

Design

- 1 retractable control dial
- Push buttons
- Left hinged door
- Side opening door with viewing window

Features

- Electronic clock timer
- 1 interior light
- Stainless steel interior

Programmes/functions

- 3 main functions:
 - microwave, combination operation, Quartz grill
- 1.2 KW grill function
- 3 weight automatic cooking programmes
- 4 weight automatic defrost programmes
- 1 weight automatic combination programme
- 1 memory function

Performance/technical information

- Oven capacity: 25 litres
- Large 25 litre stainless steel interior
- Turntable distribution
- 315 mm turntable diameter
- 5 power levels: 900 W, 600 W, 360 W, 180 W, 90 W
- 5 microwave power levels
- 900 W maximum microwave power
- User-friendly electronics: extremely
- easy and comfortable operation
- installation in tall housing

**Series 2, Built-in microwave oven, 51
x 28 cm, Stainless steel
HMT84G651B**

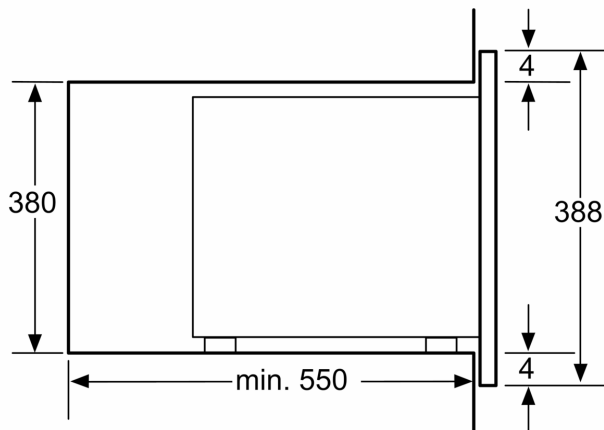

All measurements in mm

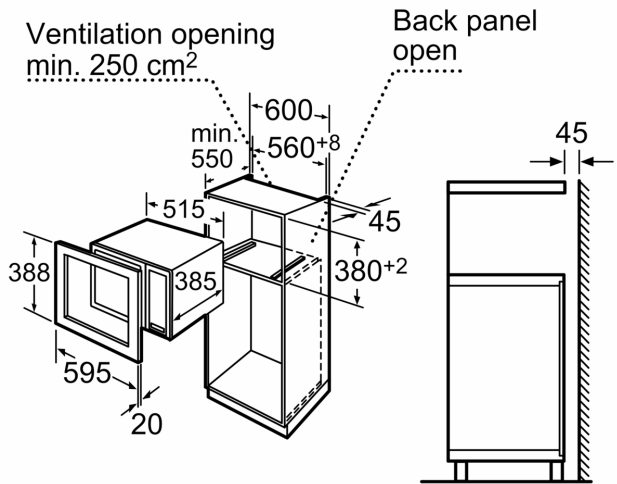

All measurements in mm

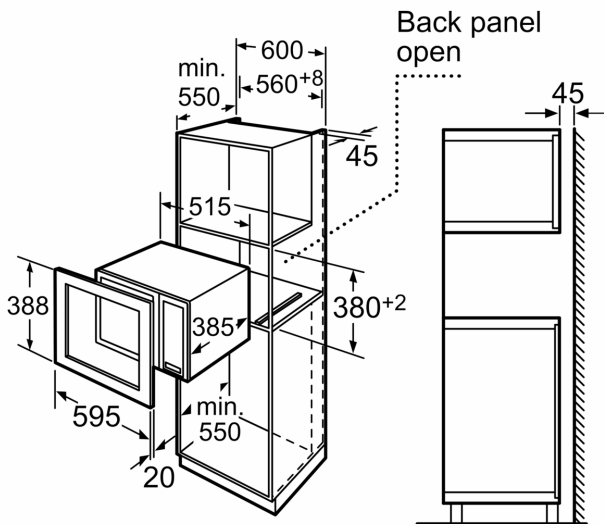

All measurements in mm