

**Series 2, Built-in microwave oven,
Stainless steel
HMT75M651B**



A great partner for the kitchen, the built-in compact microwave defrosts, heats and cooks helping you prepare food in the kitchen.

- **AutoPilot 7:** every dish is a perfect success thanks to 7 pre-set automatic programmes.
- **Red LED display control:** easy-to-use thanks to the time functions.
- **Pop-out controls:** Make the front of the oven easy to clean and give it a sleek look.
- **White LCD display control:** easy-to-use thanks to direct access to additional functions, temperature recommendation and temperature indication.
- **Microwave Boost Function:** quick and easy warming.

Technical Data

Type of micro-wave oven: MW only
 Type of control:Electronic
 Dimensions: 280 x 453 x 320 mm
 Cavity dimensions: 194.0 x 290 x 285.0 mm
 Length of electrical supply cord: 130.0 cm
 Net weight: 14.9 kg
 Gross weight: 17.2 kg
 EAN code:4242002491684
 Maximum micro-wave power:800 W
 Connection rating: 1270 W
 Fuse protection:10 A
 Voltage: 230 V
 Frequency: 50 Hz
 Plug type: GB plug



Series 2, Built-in microwave oven, Stainless steel HMT75M651B

A great partner for the kitchen, the built-in compact microwave defrosts, heats and cooks helping you prepare food in the kitchen.

Key Information

- Electronic control

Design

- Push buttons
- Left hinged door
- Side opening door with viewing window

Features

- Electronic clock timer
- 1 interior light
- Stainless steel interior

Programmes/functions

- microwave
- 3 weight automatic cooking programmes
- 4 weight automatic defrost programmes
- 1 memory function

Performance/technical information

- Oven capacity: 17 litres
- Large 17 litre stainless steel interior
- Turntable distribution
- 245 mm turntable diameter
- 5 power levels: 800 W, 600 W, 360 W, 180 W, 90 W
- User-friendly electronics: extremely
- easy and comfortable operation
- For installation into a 60 cm wide wall unit, installation in tall housing

**Series 2, Built-in microwave oven,
Stainless steel
HMT75M651B**

**Microwave ovens
in a wall-hanging
cupboard**

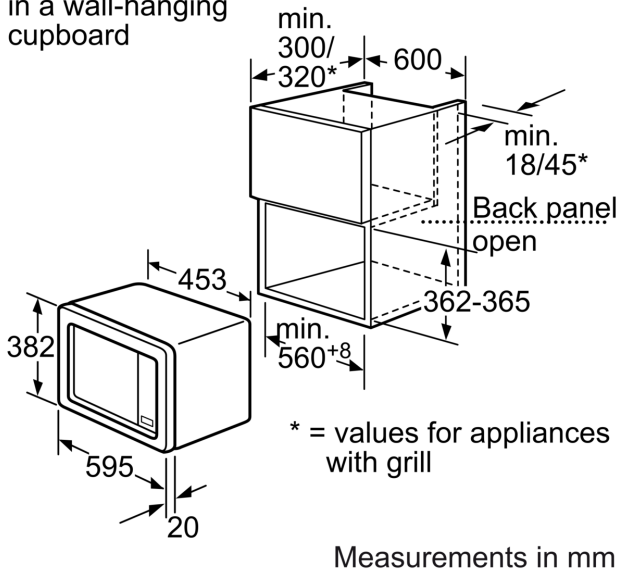

**Microwave ovens
Overlap of frame
surround**

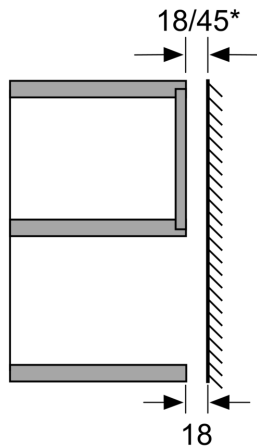
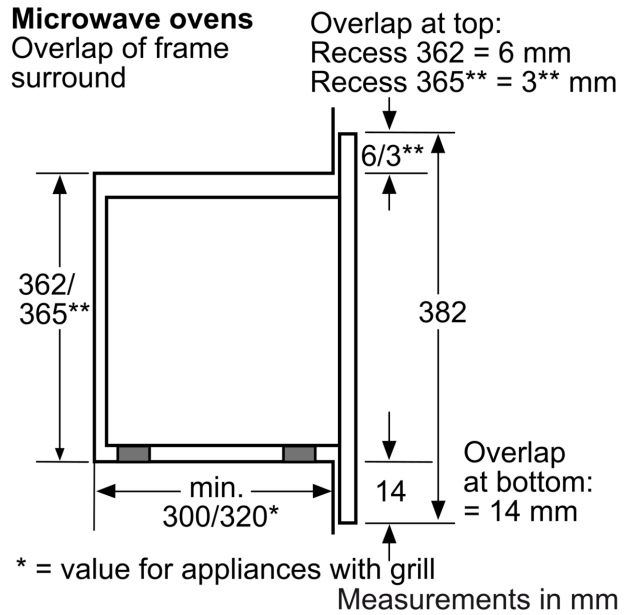

* = value for appliances with grill

Measurements in mm