

**Serie | 6, Built-in freezer, 71.2 x 55.8 cm, flat hinge  
GIV11AF30**



**The freezer with low energy and 3 transparent freezer drawers: provides ample room and a good overview - very efficient.**

- **Automatic super freezing:** for freezing smaller food loads faster whilst protecting your frozen items from defrosting, thanks to the detection of temperature increase
- **LowFrost:** defrost less often thanks to lower ice formation - saves work and is energy-efficient.
- An audible alarm system signals the door is open
- FreshSense sensors constantly monitor and control the ambient, fridge and freezer temperature
- SuperFreeze

**Technical Data**

Thermometer freeze section : None

Light : No

Product category : Upright freezer

Construction type : Built-in

Door panel options : Not possible

Frost free system : No

Height of the product : 712 mm

Width of the appliance : 558 mm

Depth of the product : 545 mm

Dimensions of the packed product (HxWxD) : 790 x 640 x 620 mm

Net weight : 36.134 kg

Gross weight : 38.5 kg

Connection rating : 90 W

Fuse protection : 10 A

Frequency : 50 Hz

Approval certificates : CE, Morocco, VDE

Length of electrical supply cord : 230 cm

Door hinge : Right reversible

Storage Period in Event of Power Failure (h) : 21 h

Defrost process : manual

Warning signal / malfunction : visual and audible

Lockable door : No

Number of drawers/baskets (Stck) : 3

Number of freezing flaps (Stck) : 0

EAN code : 4242002923819

Brand : Bosch

Product name / Commercial code : GIV11AF30

Product category : Upright freezer

Energy consumption annual - NEW (2010/30/EC) : 144.00 kWh/annum

Freezer Net capacity - NEW (2010/30/EC) : 72 l

Freezing capacity) - NEW (2010/30/EC) : 8 kg/24h

Climate class : SN-T

Noise level : 36 dB(A) re 1 pW

Installation type : Full-integrated



4 242002 923819

## Serie | 6, Built-in freezer, 71.2 x 55.8 cm, flat hinge GIV11AF30

**The freezer with low energy and 3 transparent freezer drawers: provides ample room and a good overview - very efficient.**

---

### Performance and Consumption

- Energy Efficiency Class: A++
- Energy Efficiency Class: A++ kWh/yr: 144
- Total net capacity: 72 l litres
- Noise level dB(A) re 1 pW: 36

### Design features

- Right hinged door, door reversible
- LED electronic control

### Food freshness system

- FreshSense - Constant temperature control by intelligent sensor technology

### Key features - Freezer section

- LowFrost - less ice creation and therefore quicker defrosting - less ice build up, faster defrosting
- 4 star freezer rating
- 3 freezer drawers
- 1 compressor/1 cooling circuit
- SuperFreeze function with automatic deactivation
- Freezing capacity in 24 hours: 8 kg
- Maximum freezer storage time in power failure: 21 hours

### Functions

- Freezer malfunction warning signal: optical, acoustical

### Accessories

- cold accumulator, ice cube tray

### Dimension and installation

- Climate class SN-T (suitable for ambient temperatures between 10 and 43°C)
- Connection value 90 W
- Dimensions: 71.2 cm H x 55.8 cm W x 54.5 cm D
- Niche Dimensions: 72 cm H x 56 cm W x 55 cm D

**Serie | 6, Built-in freezer, 71.2 x 55.8 cm, flat hinge  
GIV11AF30**

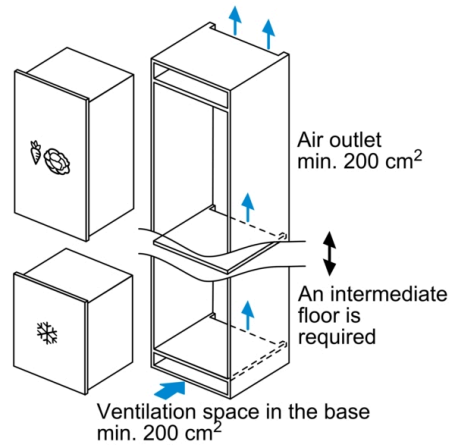
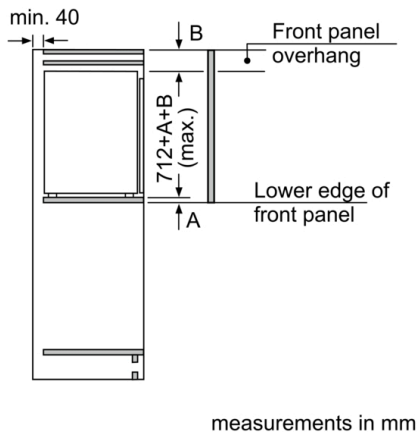
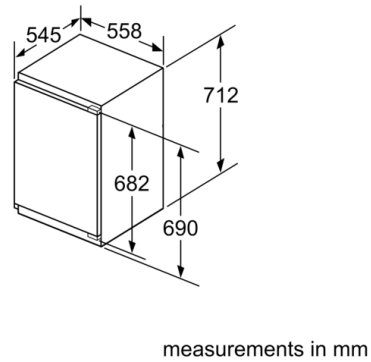
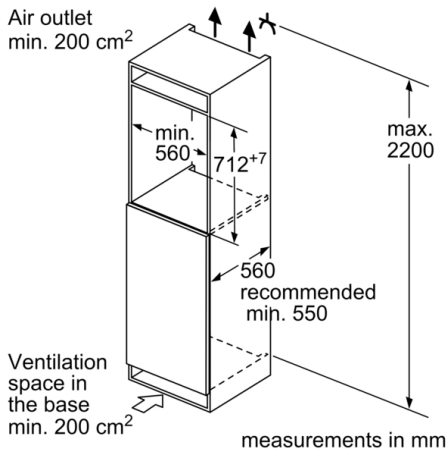

measurements in mm  
Recommended gap dimensions for flat hinges

F	R	X
16-19	0-3	2.5
20	0-1	3
	2-3	2.5
21	0-1	3
	2-3	2.5
22	0	4
	1	3.5
	2-3	3

The gap dimensions recommended in the table must be adhered to in order to ensure that appliance doors do not collide with anything when they are opened, and to avoid causing damage to kitchen units.