

**Serie | 6, Built-in freezer, 177.2 x 55.8 cm, flat hinge
GIN81AE30G**



A++

The NoFrost freezer with electronic temperature control: set the target temperature precisely and easily.

- **VarioZone:** more flexibility due to variable-use glass shelves and drawers in the freezer compartment.
- **NoFrost:** never defrost again, thanks to perfect protection from ice formation - that saves time and effort.
- **BigBox frozen food drawer:** for stacking storage containers or for large frozen food items.
- Temperature sensors continually monitor the temperature inside and outside the built-in fridge.
- An audible alarm system signals the door is open

Technical Data

Thermometer freeze section : Digital

Light : No

Product category : Upright freezer

Construction type : Built-in

Door panel options : Not possible

Frost free system : Fridge and freezer

Height of the product : 1772 mm

Width of the appliance : 558 mm

Depth of the product : 545 mm

Dimensions of the packed product (HxWxD) : 1840 x 640 x 610 mm

Net weight : 68.106 kg

Gross weight : 73.3 kg

Connection rating : 120 W

Fuse protection : 13 A

Frequency : 50 Hz

Approval certificates : CE, VDE

Length of electrical supply cord : 230 cm

Door hinge : Left reversible

Storage Period in Event of Power Failure (h) : 22 h

Warning signal / malfunction : visual and audible

Lockable door : No

Number of drawers/baskets (Stck) : 5

Number of freezing flaps (Stck) : 2

EAN code : 4242002898834

Brand : Bosch

Product name / Commercial code : GIN81AE30G

Product category : Upright freezer

Energy consumption annual - NEW (2010/30/EC) : 243.00 kWh/ annum

Freezer Net capacity - NEW (2010/30/EC) : 211 l

Freezing capacity) - NEW (2010/30/EC) : 20 kg/24h

Climate class : SN-T

Noise level : 36 dB(A) re 1 pW

Installation type : Full-integrated



Serie | 6, Built-in freezer, 177.2 x 55.8 cm, flat hinge GIN81AE30G

The NoFrost freezer with electronic temperature control: set the target temperature precisely and easily.

Performance and Consumption

- Energy Efficiency Class: A++
- Energy consumption: 1 kWh/24 hours
- Energy consumption: 243 kWh kWh/yr.
- Total net capacity: 211 l litres
- Noise level dB(A) re 1 pW: 36

Design features

- No Frost, never have to defrost ever again
- Door left hinged, door reversible
- Fixed hinge
- LED Electronic control

Food freshness system

- FreshSense - Constant temperature control by intelligent sensor technology

Key features - Freezer section

- 4 star freezer rating
- Vario Zone - removable safety glass shelves for extra space!
- 5 freezer drawers
- 2 freezer flaps with glass shelves
- 1 compressor/1 cooling circuit
- SuperFreezing function with automatic deactivation
- Freezing capacity in 24 hours: 20 kg
- Maximum freezer storage time in power failure: 22 hours

Functions

- Acoustic door open warning system
- Freezer malfunction warning signal: optical, acoustical

Accessories

- cold accumulator, ice cube tray

Dimension and installation

- Climate class SN-T (suitable for ambient temperatures between 10 and 43°C)
- Connection value 120 W
- Dimensions: 177.2 cm H x 55.8 cm W x 54.5 cm D
- Niche Dimensions: 177.5 cm H x 56 cm W x 55 cm D

**Serie | 6, Built-in freezer, 177.2 x 55.8 cm,
flat hinge
GIN81AE30G**

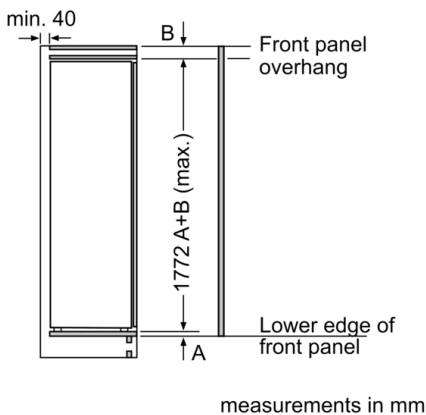
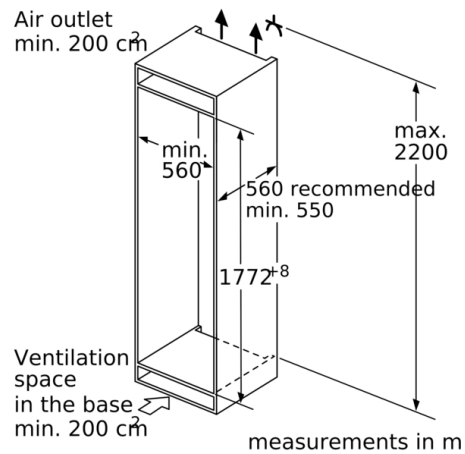
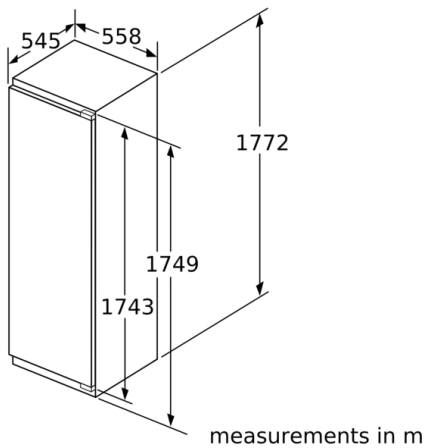

Maximal permissible weight of the unit fronts

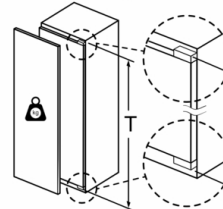

Fitted kitchen unit doors that exceed the permissible weight may cause damage and result in functional impairment of the hinges.

T: Includes height of appliance door Hinges in mm:	undamped hinge, Door in kg:	damped hinge, Door in kg:
1500-1750	22	22

measurements in mm
Recommended gap dimensions for flat hinges

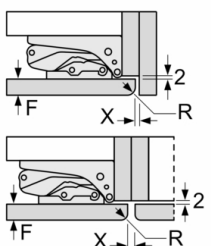

	F	R	X
16-19	0-3	2.5	
	20	0-1	3
21	2-3	2.5	
	21	0-1	3
22	2-3	2.5	
	22	0	4
	22	1	3.5
	2-3	3	

The gap dimensions recommended in the table must be adhered to in order to ensure that appliance doors do not collide with anything when they are opened, and to avoid causing damage to kitchen units.