

**Series 2, Wall-mounted cooker hood,
60 cm, Stainless steel
DWP64BC50B**



Optional accessories

DHZ1224 : Chimney extension 500 mm
DHZ5275 : Standard recirculation kit
DHZ5276 : Standard odor filter (replacement)
DHZ6551 : Brushed steel back panel

D

**Pyramid hood: perfect performance
matching your kitchen.**

- **LED Illumination:** The energy-saving lighting provides bright and clear lighting for the hob area.
- An impressive extraction rate of m³/h ensures this hood will have your kitchen odour free in no time.
- 3-speed power Level options to suit your cooking style and recipes.
- Dishwasher safe aluminum mesh filters

Technical Data

Typology : Wall-mounted
Length of electrical supply cord : 130 cm
Height of the chimney : 553-730/573-730 mm
Height of product, without chimney : 246 mm
Minimum distance above an electric hob : 550 mm
Minimum distance above a gas hob : 650 mm
Net weight : 7.6 kg
Type of control : mechanical
Number of speed settings : 3
Maximum output air extraction : 365 m³/h
Maximum output recirculating air : 211 m³/h
Number of lights (Stck) : 2
Noise level : 66 dB(A) re 1 pW
Diameter of air outlet : 120 / 150 mm
Grease filter material : Washable aluminium
EAN code : 4242005031467
Connection rating : 100 W
Fuse protection : 10 A
Voltage : 220-240 V
Frequency : 50; 60 Hz
Plug type : GB plug
Installation type : Wall-mounted



Series 2, Wall-mounted cooker hood, 60 cm, Stainless steel DWP64BC50B

Optional accessories

- Recirculating kit DHZ1224

* In accordance with the EU-Regulation No 65/2014

Pyramid hood: perfect performance matching your kitchen.

Key performance features:

- Energy Efficiency Class: D (at a range of energy efficiency classes from A+++ to D)
- Max. extraction rate: 365 m³/h
- Noise max. Normal Level: Noise, max. speed in normal us: 66 dB dB*

Features

- Push button control
- 3 power levels
- 2 x 1.5W LED light
- Colour Temperature: 3500 K
- 2 removable metal grease filter cassettes
- Installation: wall

Design

- Chimney extractor hood
- Mechanical

Performance/technical information

- Suitable for ducted or recirculating operation
- For recirculated extraction recirculating kit (accessory) needed
- Maximum extraction rate exhaust air 365 m³/h according to EN 61591
- Extraction rate in recirculation mode:
Max. normal use: 211 m³/h
- Noise level according to EN 60704-3 and EN 60704-2-13 at max. normal use exhaust air: 66 dB(A) re 1 pW
- Noise level in recirculation mode:
Max. normal use: 67 dB(A) re 1 pW (54 dB(A) re 20 µPa sound pressure)
- Power rating: 100 W
- Light Intensity: 104 lux
- Electrical cable length 1.3 m
- Diameter pipe Ø 150 mm (Ø 120 mm enclosed)
- Dimensions exhaust air (HxWxD): 799-975 x 600 x 500 mm
- Dimensions recirculating (HxWxD): 799-975 x 600 x 500 mm
- Blower Efficiency Class: E*
- Lighting Efficiency Class: A*
- Grease Filtering Efficiency Class: C*
- Average Energy Consumption: 53.1 kWh/year*

**Series 2, Wall-mounted cooker hood, 60 cm,
Stainless steel
DWP64BC50B**

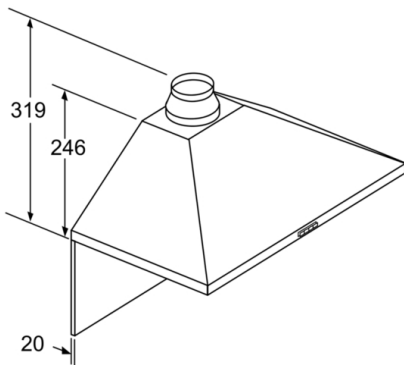

If a back panel is used,
the design of the appliance
must be considered. measurements in mm

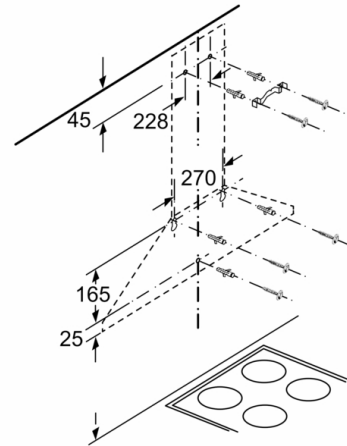

measurements in mm

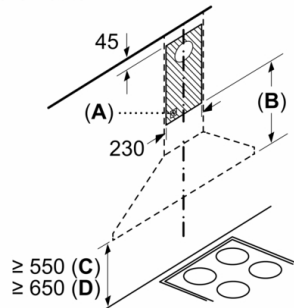

- A:** Socket
- B:** Exhaust air: ≥ 280 ; circulated air: ≥ 490
- C:** electric
- D:** Gas, from upper edge of pan support

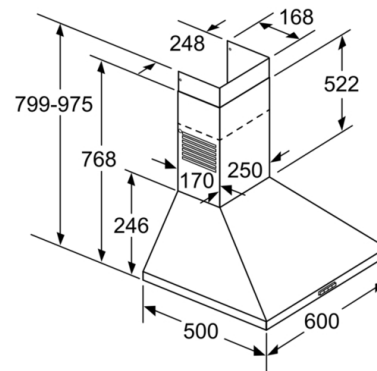

measurements in mm