

**Series 2, Wall-mounted cooker hood,
60 cm, clear glass
DWG64BC50B**



Optional accessories

DHZ1225 : Chimney extension 1000 mm
 DHZ1235 : Chimney extension 1500 mm
 DHZ6551 : Brushed steel back panel
 DWZ0XX0J0 : Long Life recirculation kit
 DWZ1DX1I4 : Clean Air Standard recirculation kit
 DWZ1DX1I6 : Clean Air Plus recirculation kit
 DWZ1FX5C6 : Clean Air Plus recirc. kit external
 DZZ1XX1B6 : Clean Air Plus odor filter (replacement)

**Hood with glass design: performance
combined with straight glass design
matching your kitchen.**

- **Silent:** maximum extractor performance with minimal noise.
- **Grease filtration level:** filters out over 85% of the grease from kitchen air.
- **LED illumination:** The energy-saving lighting provides bright and clear lighting for the hob area.
- An impressive extraction rate of m³/h ensures this hood will have your kitchen odour free in no time.
- 3-speed power Level options to suit your cooking style and recipes.

Technical Data

Typology : Wall-mounted
 Length of electrical supply cord : 130.0 cm
 Height of the chimney : 576-906/576-998 mm
 Height of the appliance : 59 mm
 Minimum distance above an electric hob : 550 mm
 Minimum distance above a gas hob : 650 mm
 Net weight : 12.8 kg
 Type of control : mechanical
 Number of speed settings : 3
 Maximum output air extraction : 365 m³/h
 Maximum output recirculating air : 240 m³/h
 Number of lights (Stck) : 2
 Noise level : 64 dB(A) re 1 pW
 Diameter of air outlet : 120 / 150 mm
 Grease filter material : Washable aluminium
 EAN code : 4242005051151
 Connection rating : 100 W
 Fuse protection : 10 A
 Voltage : 220-240 V
 Frequency : 50; 60 Hz
 Plug type : GB plug
 Installation type : Wall-mounted



4 242005 051151

Series 2, Wall-mounted cooker hood, 60 cm, clear glass DWG64BC50B

* In accordance with the EU-Regulation No 65/2014

Hood with glass design: performance combined with straight glass design matching your kitchen.

Key performance features:

- Energy Efficiency Class: D (at a range of energy efficiency classes from A+++ to D)
- Max. extraction rate: 365 m³/h
- Noise max. Normal Level: Noise, max. speed in normal us: 64 dB dB*

Features

- Push button control
- 3 power levels
- 2 x 1.5W LED light
- Colour Temperature: 3500 K
- 1 removable metal grease filter cassette
- Installation: wall

Design

- Chimney extractor hood
- Mechanical

Performance/technical information

- Suitable for ducted or recirculating operation
- For recirculated extraction recirculating kit or CleanAir recirculating kit (accessory) needed
- Maximum extraction rate exhaust air 365 m³/h according to EN 61591
- Noise level according to EN 60704-3 and EN 60704-2-13 at max. normal use exhaust air: 64 dB(A) re 1 pW
- Power rating: 100 W
- Light Intensity: 110 lux
- Electrical cable length 1.3 m
- Diameter pipe Ø 150 mm (Ø 120 mm enclosed)
- Dimensions exhaust air (HxWxD): 635-965 x 600 x 525 mm
- Dimensions recirculating (HxWxD): 635-1075 x 600 x 525 mm
- Dimensions recirculating with CleanAir module (HxWxD):
703 x 600 x 525mm - mounting with outer chimney
833-1163 x 600 x 525 mm - mounting with telescopic chimney
- Blower Efficiency Class: E*
- Lighting Efficiency Class: A*
- Grease Filtering Efficiency Class: B*
- Average Energy Consumption: 53.1 kWh/year*

Optional accessories

- Recirculating kit DHZ1225

**Series 2, Wall-mounted cooker hood, 60 cm,
clear glass
DWG64BC50B**

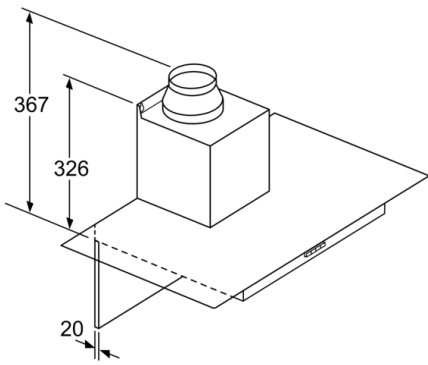

If a back panel is used,
the design of the appliance
must be considered.

measurements in mm

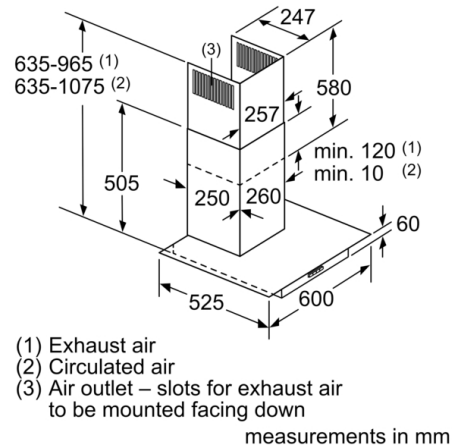
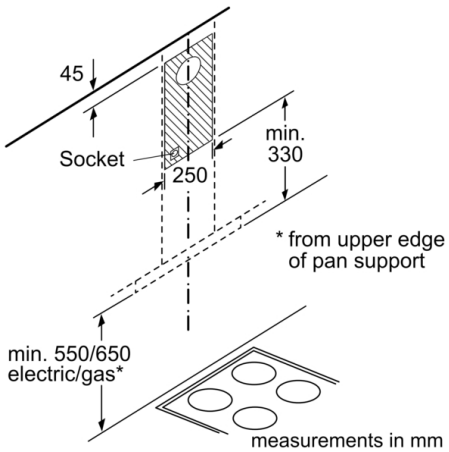
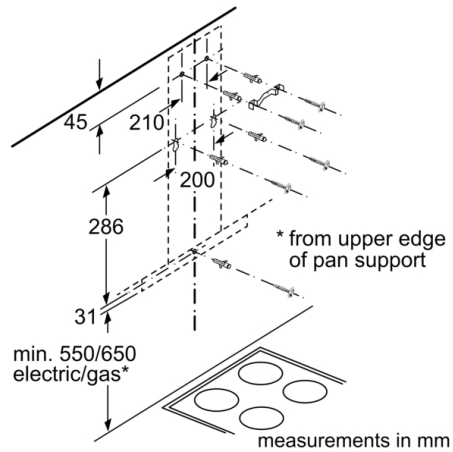

- (1) Exhaust air
- (2) Circulated air
- (3) Air outlet – slots for exhaust air to be mounted facing down