

**Series 6, Canopy cooker hood, 86 cm, Black
DLN87AC60B**



Optional accessories

DWZ1IX1C6	Clean Air Plus recirc. kit external
DWZ1IT1D1	Long Life recirculation kit external
DWZ1IX1B6	Clean Air Plus odor filter (replacement)
DHZ5316	Standard odor filter (replacement)
DHZ5605	Standard recirculation kit

Canopy hood: designed to fit neatly under an overhead unit or cabinet. They're discreet and effectively use valuable space.

- **High extraction rate - for continuously clean air in the kitchen.**
- **Quiet extraction with powerful performance**
- **Seamless integration:** thanks to flush installation, the canopy hood is almost invisible in upper cabinets.
- **LED Illumination:** the energy-saving lighting provides a clear and bright illumination for your hob area.
- **Intensive Setting:** the powerful way to beat intense steam during cooking.

Technical Data

Typology:	Built-in/Built-under
Length electrical supply cord:	150 cm
Required niche size for installation (HxWxD):	... 345mm x 676.0mm x 264mm mm
Height of the appliance:	345 mm
Minimum distance above an electric hob:	500 mm
Minimum distance above a gas hob:	650 mm
Net weight:	9.8 kg
Type of control:	Electronic
Number of speed settings:	3-stages + intensive setting
Max. air extraction:	600 m ³ /h
Boost position output recirculating:	700 m ³ /h
Max. air recirculation:	580 m ³ /h
Boost position air extraction:	745 m ³ /h
Maximum Air flow:	600 m ³ /h
Number of lights:	2
Noise level:	61 dB(A) re 1pW
Diameter of air outlet:	120 / 150 mm
Grease filter material:	Washable aluminium
EAN code:	4242005526659
Connection rating:	252 W
Fuse protection:	3 A
Voltage:	220-240 V
Frequency:	50; 60 Hz
Plug type:	GB plug
Installation typology:	Built-in



Series 6, Canopy cooker hood, 86 cm, Black DLN87AC60B

Canopy hood: designed to fit neatly under an overhead unit or cabinet. They're discreet and effectively use valuable space.

Design:

- Canopy hood
- Installation: Cabinet
- Flush-fitted installation for a seamless integration in wall cupboards.
- Suitable for ducted or recirculating operation
- For recirculated extraction various recirculation kits are available as optional accessories.

Core Features:

- 2 x 1W LED
- Colour Temperature: 4000 K
- Light Intensity: 400 lux
- Capacitor motor
- 2 metal grease filter(s).

Comfort Features:

- Soft touch button control with Electronic display
- 3 power levels & intensive setting
- Automatic reset from intensive to normal setting after 6 min

Cleaning Comfort:

- Removable metal grease filters dishwasher-safe
- Easy to clean smooth surfaces and materials.

Performance Exhaust:

- According to EN 61591 and EN/ IEC 60704-2-13 your appliance can achieve the following values in exhaust mode: Speed 1: extraction rate 285 m3/h; noise level 45 dB (A) re1pW Speed 2: extraction rate 410 m3/h; noise level 51 dB (A) re1pW Speed 3: extraction rate 600 m3/h; noise level 61 dB (A) re1pW Intensive 1: extraction rate 745 m3/h; noise level 65 dB (A) re1pW
- Energy Efficiency Class: A (at a range of energy efficiency classes from A+++ to D)
- Average Energy Consumption: 50.1 kWh/year*
- Blower Efficiency Class: A*
- Lighting Efficiency Class: A*
- Grease Filtering Efficiency Class: D*

Performance Recirculation:

- According to EN 61591 and EN/ IEC 60704-2-13 your appliance can achieve the following values in recirculation mode with standard recirculation kit (available as optional accessory): Speed 1: extraction rate 200 m3/h; noise level 59 dB (A) re1pW Speed 2: extraction rate 370 m3/h; noise level 71 dB (A) re1pW Speed 3: extraction rate 440 m3/h ; noise level 73 dB (A) re1pW Intensive Speed 1: extraction rate 460 m3/h; noise level 74 dB (A) re1pW
- According to EN 61591 and EN/ IEC 60704-2-13 your appliance can achieve the following values in recirculation mode with Clean Air plus recirculation kit, for chimless installation (available as optional accessory): Speed 1: extraction rate 270 m3/h ; noise level 51 dB (A) re1pW Speed 2: extraction rate 390 m3/h ; noise

level 71 dB (A) re1pW Speed 3: extraction rate 580 m3/h ; noise level 69 dB (A) re1pW Intensive Speed 1: extraction rate 700 m3/h ; noise level 74 dB (A) re1pW)

Technical Information and Sustainability:

- Consumption data:
- Power rating: 252 W
- Voltage: Nominal voltage: 220 - 240 V
- Sustainability:
- Environmentally friendly packaging
- Available odour filter as regenerative Long Life filter with 10 years lifetime

Planning and Installation Information:

- Dimensions (HxWxD): 345 x 860 x 282 mm
- Dimensions recirculating (HxWxD): 345-345 x 860 x 282 mm
- Built-in dimensions (HxWxD): 345 x 676 x 264 mm
- Please reference the built-in dimensions provided in the installation drawings
- Electrical cable length 1.5 m
- Diameter pipe Ø 150 mm (Ø 120 mm enclosed)
- Back-pressure flap: Yes

**Series 6, Canopy cooker hood, 86 cm, Black
DLN87AC60B**

Measurements in mm

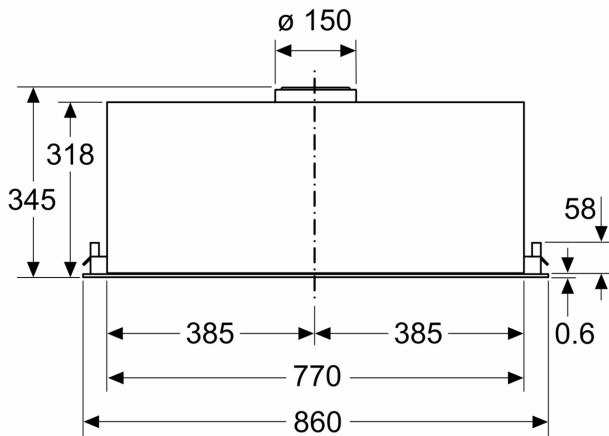

Measurements in mm

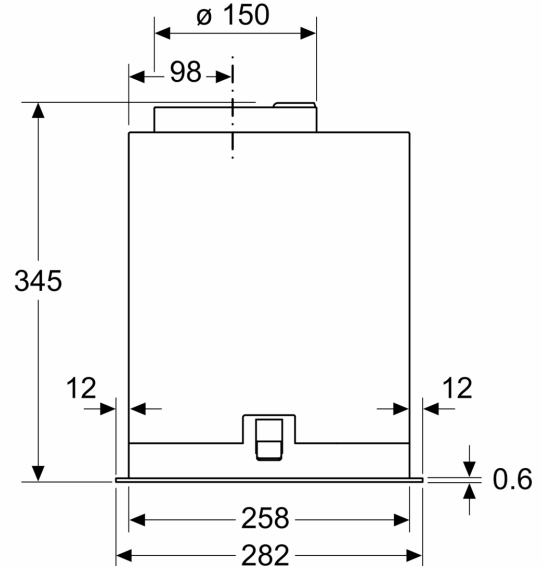

Measurements in mm

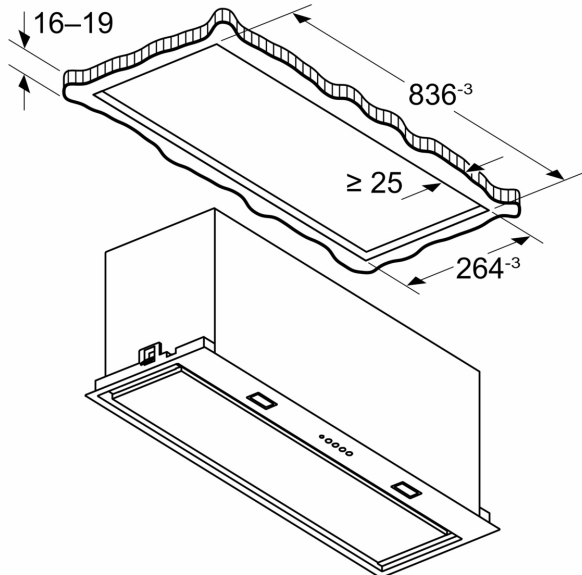

Measurements in mm

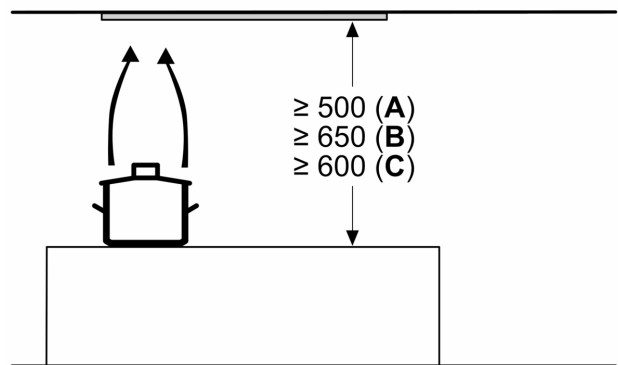

A: Electric

B: Gas - from upper edge of pan support

C: Electric - for Australia and New Zealand