

**Series 4, washing machine,
frontloader fullsize, 9 kg, ,
WGA144XVEG**



- **EcoSilence Drive™**: extremely energy-efficient and quiet in operation with a 10-year warranty.
- **AllergyPlus**: specially developed for the needs of allergy sufferers and sensitive skin.
- **SpeedPerfect**: perfectly clean in up to 65% less time.
- **VarioDrum**: gently and efficiently wash by evenly water distribution and without creasing garments.
- **Large LED display**: Easy operation and extra functions available.

Technical Data

Built-in / Free-standing : Free-standing
 Door hinge : Left
 Color / Material body : Silver inox
 Length electrical supply cord : 160 cm
 Height for building under : 845.00 mm
 Height of the product : 845 mm
 Dimensions of the product : 845 x 597 x 588 mm
 Wheels : No
 Net weight : 65.2 kg
 Drum volume : 63 l
 Main colour of product : Silver inox
 Door Frame : Silver-inox, black-grey
 Color Dial : Chrome-black
 Noise level washing : 51 dB(A) re 1 pW
 Connection Rating : 2300 W
 Fuse protection : 10 A
 Voltage : 220-240 V
 Frequency : 50 Hz
 Energy Star Qualified : No
 Cord included : No
 Plug type : GARDY plug w/ earthing
 Length of drain hose (in) : 59.05
 Length of supply hose (in) : 59.05
 Appliance Dimensions (h x w x d) (inches) : x x
 Dimensions of the packed product : 34.52 x 25.31 x 26.77
 Net weight : 144.000 lbs
 Gross weight : 154.000 lbs
 Length of drain hose : 150.00 cm
 Length of supply hose : 150.00 cm
 Dimensions of the packed product (HxWxD) : 877 x 680 x 643 mm
 Gross weight : 69.8 kg
 Connection Rating : 2300 W
 Fuse protection : 10 A
 Voltage : 220-240 V
 Frequency : 50 Hz
 Energy consumption : 2.00 kWh
 Water protection system : Multiple water protection
 Number of Options : 8
 Maximum spin speed : 1400 rpm
 Spin speed options : Variable
 Digital countdown indicator : Yes
 Progress indicator : LED, LED-display



Series 4, washing machine, frontloader fullsize, 9 kg, , WGA144XVEG

- WGA144XVEG
- Automatic Washing Machine, , built-under
- EcoSilence Drive: quiet motor with long lifetime
- 10 years guaranty on EcoSilence Drive

engine power and consumption

- rated capacity: 9 kg
- Spin-drying efficiency class: B
- max.spin speed 1400 rpm**
- Indication that cotton 60° + button EcoPerfect and cotton 40° + button EcoPerfect are the standard washing programmes to which the information in the label and the fiche relates, that these programmes are suitable to clean normally soiled cotton laundry and that they are the most efficient programmes in terms of combined energy and water consumption. The actual temperature may vary with this combination from the specified program temperature. Washing times will be extended for the benefit of lower energy consumption. Washing effect A is always guaranteed in the process.
- Noise level washing in standard 60° cotton programme at full load in dB (A) re 1 pW: 51
- Noise level spinning at standard 60°C cotton programme at full loading in dB (A) re 1 pW: 75

Programmes

- Special programmes: allergy plus, Drum Clean, easy care plus, Spin / Drain, Family Mix, single rinse, Duvet, Quick 15'/30', curtain

options

- PreSoaking: Works against stubborn stains.
- AntiStain: Automatic removal of the most common stains.
- VarioPerfect: time- or energy optimized programs with perfect wash performance
- TouchControl buttons: stain selection, SpeedPerfect, Pre-treatment, start/pause with reload function, Temperature, Spin speed selection, Easy Iron, end time delay/Rinse hold

comfort and safety

- Reload function: Be flexible in adding laundry items even after start of the wash cycle.
- VarioDrum™: gentle or intensive washing
- Multiple water protection
- Large display for temperature, spin speed, remaining time, 24 h end time delay and load recommendation
- Fully electronic control dial for all wash- and special programs
- AntiVibration Design: more stability and quietness
- 3D AquaSpar wash system with cascade for faster water penetration
- Continuous automatic load adjustment system
- loading introduction
- Foam detection system to remove excessive foam
- Unbalanced load detection
- Easy Cleaning Drawer
- Overdosage indication
- Child-proof lock
- Buzzer at the end of the programme
- Metal door closing hook
- comfort lock

Technical Information

- Dimensions (H x W x D): 84.5 cm x 59.7 cm x 58.8 cm
- Slide-under height of 85cm

**Series 4, washing machine, frontloader
fullsize, 9 kg, ,
WGA144XVEG**

measurements in mm

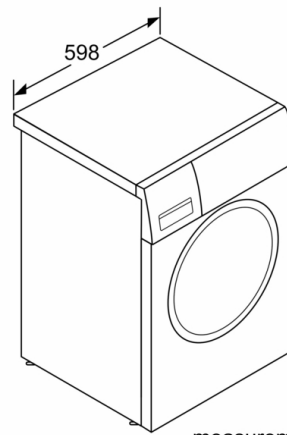
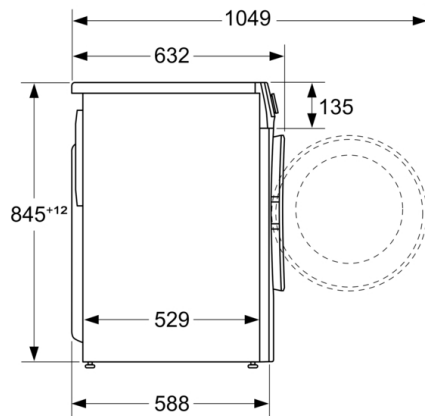

measurements in mm