

**Series 8, Mixed hob (gas and electric), 60 cm, ,  
PRY6A6B70Q**



HEZ298105 Simmer plate  
HEZ298114 Small pot support

**The ceramic glass gas hob with  
FlameSelect: achieve perfect cooking  
results thanks to nine precisely defined  
power levels.**

- **Heavy-duty continuous surface grates can be easily and quickly cleaned in the dishwasher.**
- **Continuous cast-iron pan support: for high firmness and stability of cookware.**
- **Sword knobs: for an ergonomic control.**
- **FlameSelect® - Allows for a Precise Adjustment of the Flame Size with Nine Defined Power Levels**
- **Precise Temperature Control for Better Cooking Results**

Product name/family: ..... mixed hob w integr controls  
 Built-in / Free-standing: ..... Built-in  
 Energy input: ..... Mixed fuel - gas and electric  
 Total number of positions that can be used at the same time: ..... 3  
 Type of control setting devices: ..... sword knobs  
 Min. required niche size for installation (HxWxD): .....45 x 560-562 x 490-502 mm  
 Width of the appliance: ..... 606 mm  
 Dimensions: ..... 47 x 606 x 527 mm  
 Dimensions of the packed product (HxWxD): ..... 165 x 677 x 579 mm  
 Net weight: ..... 10.8 kg  
 Gross weight: ..... 12.0 kg  
 Residual heat indicator: .....No  
 Location of control panel: ..... Front  
 Basic surface material: .....Ceramic  
 Color of surface: .....Black, Alu, brushed  
 Color of frame: ..... Black  
 Length electrical supply cord: ..... 100.0 cm  
 Knob Material: .....Plastic  
 Sealed Burners: ..... No  
 Type of pan support: ..... Elongated cast iron pan support  
 Power of 3rd heating element (kW): ..... 1.1 kW  
 Power of 5th heating element (kW): ..... 2.8 kW  
 Connection rating: ..... 1800 W  
 Gas connection rating: ..... 5800 W  
 Fuse protection: .....10 A  
 Voltage: ..... 220-240 V  
 Frequency: ..... 50; 60 Hz  
 Energy input: ..... Mixed fuel - gas and electric  
 Gas type: ..... Nat gas H/E/(L) 20 (25) mbar  
 Alternative gas type: ..... Liquid gas G30,31 28-30/37mbar  
 Plug type: ..... Gardy plug w/ earthing  
 Appliance Dimensions (h x w x d) (in): ..... x x  
 Dimensions of the packed product: ..... 6.49 x 22.79 x 26.65  
 Net weight: .....24.000 lbs  
 Gross weight: ..... 26.000 lbs  
 Total number of positions that can be used at the same time: ..... 3  
 Length electrical supply cord: ..... 100.0 cm  
 Min. required niche size for installation (HxWxD): .....45 x 560-562 x 490-502 mm  
 Dimensions: .....47 x 606 x 527 mm  
 Dimensions of the packed product (HxWxD): ..... 165 x 677 x 579 mm  
 Net weight: ..... 10.8 kg  
 Gross weight: ..... 12.0 kg



## Series 8, Mixed hob (gas and electric), 60 cm, , PRY6A6B70Q

**The ceramic glass gas hob with FlameSelect: achieve perfect cooking results thanks to nine precisely defined power levels.**

---

### **Design:**

- Ceramic glass

### **Comfort:**

- FlameSelect
- Sword control knobs
- 1 Hand ignition
- Cast iron continuous pan supports
- Pan supports dishwasher proof

### **Power and size:**

- 3 Gas burners
- 3 Gas burners and 1 Electric cooking zone
- 1 Rapid-, 1 Normal-, 1 Economy burner, 1 Electric cooking zone
- Left rear: Economy burner up to 1.1 KW (depending on gas type)
- Right rear: Rapid burner up to 2.8 KW (depending on gas type)
- Left front: Dual-circuit zone up to 0.7 KW, 1.8 KW (depending on gas type)
- Right front: Standard burner up to 1.9 KW (depending on gas type)

### **Environment+safety:**

- Flame failure safety device
- Preset for natural gas (20mbar). Also usable for NG H/E 20mbar, E+ 20/25mbar
- Liquid gas G30,31 28-30/37mbar. For the use of these gas types nozzles need to be changed. Please check if the required nozzles are included (see Accessories).

### **Measurements:**

- Power cord length 1m

### **Accessories**

- Nozzle set for Liquid gas nozzles (28-30/37mbar) included. Nozzles for all other gas types can be ordered via the customer service.

**Series 8, Mixed hob (gas and electric), 60 cm, ,  
PRY6A6B70Q**

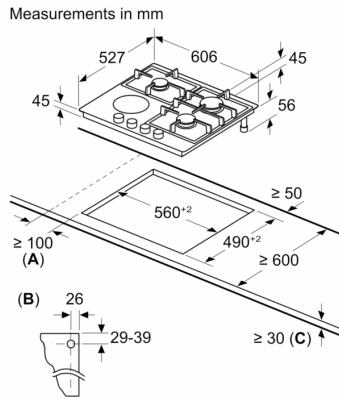

**A:** Min. distance from the hob cut-out to the wall

**B:** Position of gas connection in the cut-out

**C:** With fitted oven underneath possibly more; see space requirements for the oven