

**Series 2, Built-in oven, 60 x 60 cm,  
Stainless steel  
HBF113BR0Q**



1 x enamel baking tray, 1 x combination grid, 1 x universal pan

- HEZ317000 Pizza pan, enamelled
- HEZ327000 Pizza stone
- HEZ425001 Grill tray
- HEZ431002 Baking tray, antrasit enamelled
- HEZ625071 Grill tray, anthracite
- HEZ915003 Glass roasting dish, 5,4 L

**The built-in oven with 3D hotair: achieve perfect baking and roasting results on up to three levels simultaneously.**

- **LED-display control, red:** easy-to-use thanks to the time functions.

Gross weight: ..... 34.7 kg  
 Built-in / Free-standing: ..... Built-in  
 Integrated Cleaning system: .....Hydrolytic  
 Required niche size for installation (HxWxD): .....575-597 x 560-568 x 550 mm  
 Dimensions: ..... 595x594x548 mm  
 Dimensions of the packed product (HxWxD): .....680x655x680 mm  
 Control Panel Material: ..... Stainless steel  
 Door Material: ..... Glass  
 Net weight: ..... 32.5 kg  
 Usable volume of cavity: ..... 66 l  
 Heating modes:: .....Hotair gentle, Hot Air, Conventional heat, Hot air grilling, Full width variable grill  
 Length electrical supply cord: ..... 100 cm  
 Pull-out system: ..... Not applicable  
 Included accessories: 1 x enamel baking tray, 1 x combination grid, 1 x universal pan  
 Broil Element Wattages cavity 1: .....2800 W  
 Energy efficiency class: .....A  
 Energy consumption per cycle conventional (2010/30/EC): .....0.98 kWh/cycle  
 Energy consumption per cycle forced air convection (2010/30/EC):79 kWh/cycle  
 Energy efficiency index (2010/30/EC): ..... 95.2 %  
 Connection rating: ..... 3300 W  
 Fuse protection: ..... 16 A  
 Voltage: ..... 220-240 V  
 Frequency: ..... 60; 50 Hz  
 Plug type: ..... Gardy plug w/ earthing  
 Energy input: .....Electric  
 Required cutout/niche size for installation (in): .....X  
 Dimensions of the packed product: ..... 26.77 x 25.78 x 26.77  
 Net weight: ..... 72.000 lbs  
 Gross weight: ..... 76.000 lbs



## **Series 2, Built-in oven, 60 x 60 cm, Stainless steel HBF113BR0Q**

**The built-in oven with 3D hotair: achieve perfect baking and roasting results on up to three levels simultaneously.**

---

### **Type of oven / heating system:**

- Oven with 5 heating methods: 3D hotair, Conventional heat, Hot air grilling, Hotair gentle, Full width variable grill
- Temperature range 50 °C - 275 °C
- Cavity volume: 66 l

### **Hook-in racks / rails**

- Not available

### **Design:**

#### **Cleaning:**

- Innerdoor main: Full glass inner door

#### **Comfort:**

- LED-display control (red)
- Electronic clock
- Drop down door
- Fast preheat
- Halogen interior lighting
- Integral cooling fan

#### **Accessory:**

- universal pan, combination grid, enamel baking tray

#### **Environment and Safety:**

- Child lock

#### **Technical Information**

- Length of mains cable: 100 cm
- Nominal voltage: 220 - 240 V
- Total connected load electric: 3.3 KW
- Energy efficiency rating (acc. EU Nr. 65/2014): A(at a range of energy efficiency classes from A+++ to D)
- Energy consumption per cycle in conventional mode: 0.98 kWh
- Energy consumption per cycle in fan-forced convection mode: 0.79 kWh
- Number of cavities: 1
- Heat source: electrical
- Cavity volume: 66 l

#### **Dimensions:**

- Appliance dimension (hxwx): 595 mm x 594 mm x 548 mm
- Niche dimension (hxwx): 575 mm - 597 mm x 560 mm - 568 mm x 550 mm
- "Please reference the built-in dimensions provided in the installation drawing"

**Series 2, Built-in oven, 60 x 60 cm,  
Stainless steel  
HBF113BR0Q**

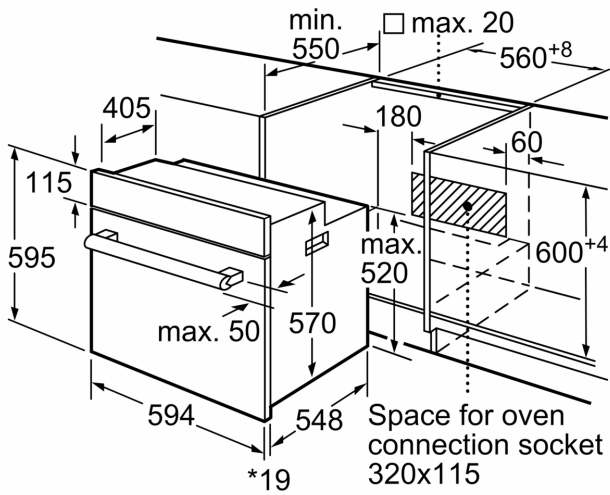

\* 20 mm for metal fascias

measurements in mm

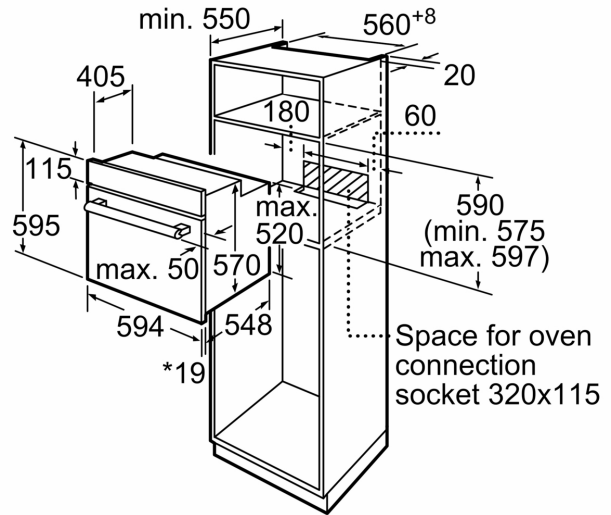

\* 20 mm for metal fascias

measurements in mm

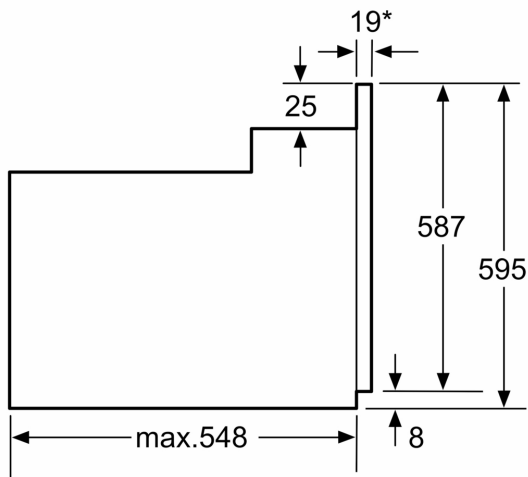

\* 20 mm for metal fascias

Dimensions in mm