

**Series 2, telescopic cooker hood, 60 cm, Black
DFT63CA60Q**



DWZ1IX1G9 Wall bracket

The telescopic cooker hood: practically disappears into your upper cabinet, giving you a sleek kitchen front.

- **Silent:** maximal extractor performance with little noise
- **Metal Grease Filter:** cleans the air, captures grease, easy monthly clean-up.
- **3-Speed Power Level Options To Suit Your Cooking Style And Recipes**
- **Ducted or Non-ducted Options**

Typology: Pull-out
 Length electrical supply cord: 130.0 cm
 Min. required niche size for installation (HxWxD): 135mm x 598.0mm x 264mm mm
 Net weight:6.8 kg
 Type of control:mechanical
 Number of speed settings: 3
 Max. air extraction:300 m³/h
 Max. air recirculation: 220 m³/h
 Number of lights: 2
 Noise level:62 dB(A) re 1 pW
 Diameter of air outlet: 150 mm
 Grease filter material:Washable aluminium
 Odour filter: No
 Operating Mode:Exhaust / Recirculation (Accessory available separately)
 Optional accessories:DWZ1IX1G9
 Total power of the lamps: 8 W
 Grease filter type:Kassette
 Connection rating: 181 W
 Voltage: 220-240 V
 Frequency: 50 Hz
 Plug type: Gardy plug w/ earthing
 Installation typology: Built-in
 Material body: Lacquered
 Plug type: Gardy plug w/ earthing
 Dimensions of the product, with chimney (if exists) (in):x x
 Dimensions of the packed product: 13.77 x 25.59 x 9.84
 Net weight: 15.000 lbs
 Gross weight: 17.000 lbs
 Motor location: Integrated motor in hood body
 No-return airflow flap: No
 Length electrical supply cord: 130.0 cm
 Dimensions of the product, with chimney (if exists):175 x 600.0 x 280.0 mm
 Dimensions of the packed product (HxWxD): 350 x 650 x 250 mm
 Net weight:6.8 kg
 Gross weight: 7.6 kg



**Series 2, telescopic cooker hood, 60 cm, Black
DFT63CA60Q**

measurements in mm

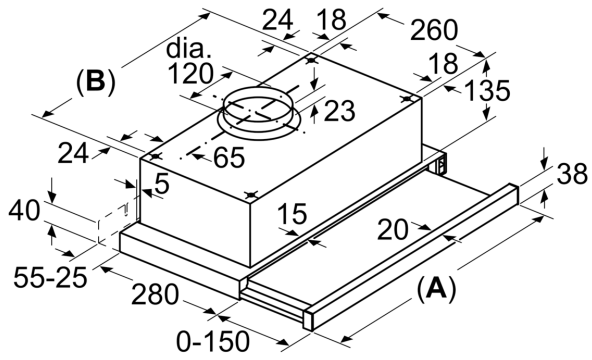

Hood Type	A	B	Hood Type	A	B
450	448	348	700	698	598
500	498	398	800	798	698
550	548	448	900	898	798
600	598	498			