

500 Series, Electric Freestanding Range, 30", Stainless steel HES5053C



Included accessories
2 x grid

Technical Data

Total number of cooktop burners :	5
Cooking mode :	
Convection Bake, Conventional heat, Half width variable grill	
Integrated Cleaning system :	Self Clean
Type of control :	Electronic
Knob Material :	Plastic
Included accessories :	2 x grid
Sealed Burners :	No
Bake Element Wattages cavity 1 (W) :	3500
Broil Element Wattages cavity 1 (W) :	3600
Number of gas burners :	0
Location of 1st heating element :	front left
Location of 2nd heating element :	center left
Location of 3rd heating element :	back left
Location of 4th heating element :	middle back
Location of 5th heating element :	back right
Location of 6th heating element :	center right
Display Color :	7-segment, red
UPC code :	825225880882
Current (A) :	40
Volts (V) :	240/208
Frequency (Hz) :	60
Approval certificates :	CSA
Required cutout size (HxWxD) (in) :	30" width slide-in
Overall appliance dimensions (HxWxD) (in) :	47 3/4" x 29 7/8" x 25 3/4"
Variable cooker height (in) :	3/4"
Product packaging dimensions (HxWxD) (in) :	50" x 32" x 29 1/2"
Net weight (lbs) :	159
Gross weight (lbs) :	180

500 Series, Electric Freestanding Range, 30", Stainless steel HES5053C

Key Features

- Convection Saves Time and Energy. A Fan Provides Even Heat Distribution Throughout the Cavity for Superior Cooking Results.
- Power Element - Quick Heating with Powerful 2,700 W Element.
- Extra Large 12 Inch Element Offers the Capability to Use Multiple Pan Sizes.
- Dual Element offers the Capability to use Multiple Pan Sizes

Design

- Design Fits to Bosch Family Look.
- Recommended Companion to other Bosch 500 Series Products.

Performance

- Convection Saves Time and Energy. A Fan Provides Even Heat Distribution Throughout the Cavity for Superior Cooking Results.
- Power Element - Quick Heating with Powerful 2,700 W Element.
- Extra Large 12 Inch Element Offers the Capability to Use Multiple Pan Sizes.
- 100W Warming Zone - Perfect for Keeping Food Ready to Serve or Prewarming Dishes.
- Dual Element Offers the Capability to use Multiple Pan Sizes.

Convenience

- Two Racks and Seven Different Rack Positions Adjust for All Cooking Needs.
- Self Clean Cycle Saves Time. Quickly and Easily Cleans your Oven.
- Wide View Oven Window - Extra large Window Provides Easy Viewing of Your Food.
- True Hidden Bake Element

Capacity

- Large Cavity with 5.4 cu ft. Easily Accommodates Large Dishes and Offers Multiple Rack Cooking.

**500 Series, Electric Freestanding Range,
30", Stainless steel
HES5053C**

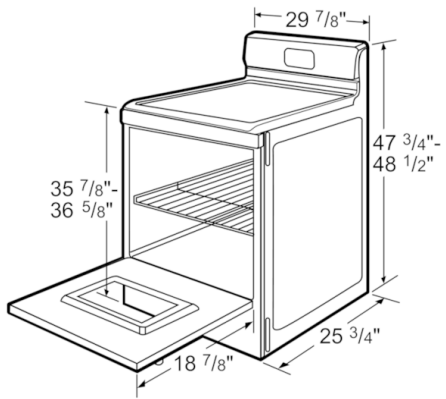

Dimensions in inches