

**Series 8, Built-in vacuum drawer, 60  
x 14 cm, Black  
BVE9101B1**



HEZ32WA00 Wireless food thermometer

**Vacuum drawer designed for preparing dishes for sous vide cooking. Vacuum-packed food that is steamed in a full steam appliance at a constant low temperature.**

- **Vacuum drawer:** for the preparation of dishes for sous vide cooking.
- **99% vacuum:** perfect for vacuum sealing food.
- **Push-pull mechanism:** easy opening and closing thanks to a practical spring mechanism.

---

Color / Material Front: ..... Black  
Built-in / Free-standing: ..... Built-in  
Dimensions (HxWxD): ..... 140 x 595 x 542 mm  
Dimensions of the packed product (HxWxD): ..... 230 x 660 x 660 mm  
Min. required niche size for installation (HxWxD): ..... 141 x 560 x 550 mm  
Net weight: ..... 31.7 kg  
Gross weight: ..... 33.6 kg  
EAN code: ..... 4242005330133  
Fuse protection: ..... 6 A  
Voltage: ..... 220-240 V  
Frequency: ..... 50; 60 Hz

---



**Series 8, Built-in vacuum drawer, 60  
x 14 cm, Black  
BVE9101B1**

**Vacuum drawer designed for preparing  
dishes for sous vide cooking.  
Vacuum-packed food that is steamed in a  
full steam appliance at a constant low  
temperature.**

---

**Vacuumping levels:**

- 3 vacuumping levels for vacuumping in the chamber, max. 99%
- 3 vacuumping levels for vacuumping outside the chamber, max. 90%
- 3 heat sealing durations for different bag thicknesses and materials.

**Design**

- stainless steel cavity
- Illuminated TouchSelect controls
- Touch key operation

**Convenience**

- Cavity volume: 8 l
- Handleless push&pull opening mechanism
- Automatic connection recognition for vacuumping outside the chamber
- Drying program for vacuumping pump
- Locking mechanism prevents the drawer from closing accidentally.
- The vacuumping bags are held by a clip safely in their position.

**Accessories**

- 1 x Adaptor f. vacuumping outside the chamber, 1 x Adaptor for bottle plugs, 3 x Plugs for vacuumping of bottles, 50 x Vacuumping bag, big, 50 x Vacuumping bag, small, 1 x Vacuumping hose

**Safety and Environment**

- Door contact switch

**Technical Info**

- Length of mains cable: 150 cm
- Total connected load electric: 0.32 KW
- Nominal voltage: 220 - 240 V

**Dimensions**

- Appliance dimensions (HxWxD): 140 mm x 595 mm x 542 mm
- Please reference the built-in dimensions provided in the installation drawing

**Series 8, Built-in vacuum drawer, 60  
x 14 cm, Black  
BVE9101B1**

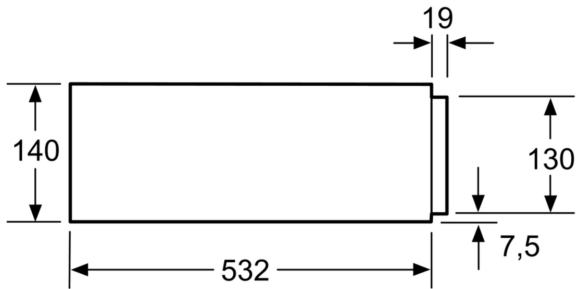

Compact ovens with an appliance height of 455 mm can be installed above a vacuum sealing drawer. An intermediate floor is not required.

measurements in mm

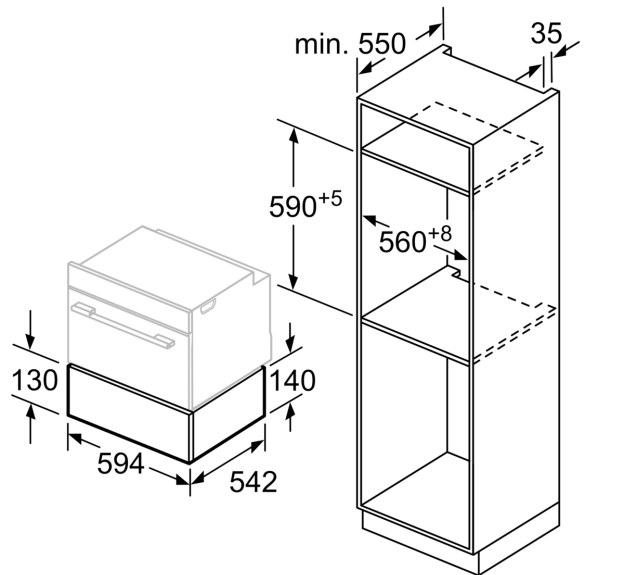

measurements in mm