



**BOSCH**



**Register** your  
new appliance  
now at MyBosch and  
enjoy benefits free of  
charge:  
[bosch-home.com/  
welcome](https://bosch-home.com/welcome)

# Washing machine

**WHE25300HK**

**[en]** User manual and installation instructions



**You can find additional information and explanations online.  
Scan the QR code on the title page.**



## Table of contents

<b>1 Safety .....</b>	<b>3</b>	<b>11 Laundry .....</b>	<b>23</b>
1.1 General information .....	3	11.1 Preparing the laundry .....	23
1.2 Intended use .....	3	11.2 Care symbols on the care labels .....	24
1.3 Restriction on user group .....	3	<b>12 Detergents and care products .....</b>	<b>24</b>
1.4 Safe installation .....	4	<b>13 Basic operation .....</b>	<b>24</b>
1.5 Safe use .....	6	13.1 Switching on the appliance ..	24
1.6 Safe cleaning and maintenance .....	8	13.2 Setting a programme .....	24
<b>2 Preventing material damage .....</b>	<b>8</b>	13.3 Saving programme settings .....	24
<b>3 Environmental protection and saving energy .....</b>	<b>9</b>	13.4 Opening the door .....	25
3.1 Disposing of packaging .....	9	13.5 Loading laundry .....	25
3.2 Save energy and conserve resources .....	10	13.6 Adding detergent and care product .....	25
3.3 Energy saving mode .....	10	13.7 Starting the programme .....	25
<b>4 Installation and connection .....</b>	<b>10</b>	13.8 Soaking laundry .....	25
4.1 Unpacking the appliance .....	10	13.9 Adding laundry .....	25
4.2 Contents of package .....	10	13.10 Cancelling the programme .....	26
4.3 Requirements for the installation location .....	11	13.11 Unloading the laundry .....	26
4.4 Removing foam parts .....	11	13.12 Switching off the appliance .....	26
4.5 Removing the transit bolts .....	12	<b>14 Childproof lock .....</b>	<b>26</b>
4.6 Connecting the appliance .....	12	14.1 Activating the childproof lock .....	26
4.7 Aligning the appliance .....	13	14.2 Deactivating the childproof lock .....	26
<b>5 Before using for the first time ..</b>	<b>14</b>	<b>15 Cleaning and servicing .....</b>	<b>26</b>
5.1 Starting an empty washing cycle .....	14	15.1 Cleaning the drum .....	27
<b>6 Familiarising yourself with your appliance .....</b>	<b>15</b>	15.2 Cleaning the detergent drawer .....	27
6.1 Appliance .....	15	15.3 Cleaning the drain pump .....	28
6.2 Detergent drawer .....	16	15.4 Cleaning the rubber gasket ..	30
6.3 Control panel .....	17	<b>16 Troubleshooting .....</b>	<b>30</b>
<b>7 Display .....</b>	<b>17</b>	16.1 Emergency release .....	34
<b>8 Buttons .....</b>	<b>18</b>		
<b>9 Programmes .....</b>	<b>20</b>		
<b>10 Accessories .....</b>	<b>23</b>		

<b>17 Transportation, storage and disposal .....</b>	<b>35</b>	<b>18 Customer Service .....</b>	<b>35</b>
17.1 Removing the appliance .....	35	18.1 Product number (E-Nr.) and production number (FD) .....	35
17.2 Inserting the transit bolts .....	35	<b>19 Consumption values .....</b>	<b>36</b>
17.3 Using the appliance again ....	35	<b>20 Technical data .....</b>	<b>36</b>
17.4 Disposing of old appliance ...	35		



## 1 Safety

Observe the following safety instructions.

### 1.1 General information

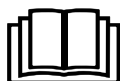

- Read this instruction manual carefully.
- Keep the instruction manual and the product information safe for future reference or for the next owner.
- Do not connect the appliance if it has been damaged in transit.

### 1.2 Intended use

Only use this appliance:

- for washing machine-washable fabrics and hand-washable wool in accordance with the care label.
- with tap water and commercially available detergents and care products suitable for washing machines.
- in private households and in enclosed spaces in a domestic environment.
- Up to an altitude of 4000 m above sea level.

### 1.3 Restriction on user group

This appliance may be used by children aged 8 or over and by people who have reduced physical, sensory or mental abilities or inadequate experience and/or knowledge, provided that they are supervised or have been instructed on how to use the appliance safely and have understood the resulting dangers.

Do not let children play with the appliance.

Cleaning and user maintenance must not be performed by children unless they are being supervised.

Keep children under the age of 3 years and pets away from the appliance.

## 1.4 Safe installation

### **⚠ WARNING – Risk of electric shock!**

Incorrect installation is dangerous.

- ▶ Connect and operate the appliance only in accordance with the specifications on the rating plate.
- ▶ Connect the appliance to a power supply with alternating current only via a properly installed socket with earthing.
- ▶ The protective conductor system of the domestic electrical installation must be properly installed. The installation must have a sufficiently large cross section.
- ▶ When using a residual current circuit breaker, only use a type with the  mark.
- ▶ Never equip the appliance with an external switching device, e.g. a timer or remote control.
- ▶ When the appliance is installed, the mains plug of the power cord must be freely accessible. If free access is not possible, an isolating switch must be integrated into the permanent electrical installation according to the installation regulations.
- ▶ When installing the appliance, check that the power cable is not trapped or damaged.

If the insulation of the power cord is damaged, this is dangerous.

- ▶ Never let the power cord come into contact with hot appliance parts or heat sources.
- ▶ Never let the power cord come into contact with sharp points or edges.
- ▶ Never kink, crush or modify the power cord.

### **⚠ WARNING – Risk of fire!**

It is dangerous to use an extended power cord and non-approved adapters.

- ▶ Do not use extension cables or multiple socket strips.
- ▶ Only use adapters and power cords approved by the manufacturer.
- ▶ If the power cord is too short and a longer one is not available, please contact an electrician to have the domestic installation adapted.

**⚠ WARNING – Risk of injury!**

The heavy weight of the appliance may result in injury when lifted.

- ▶ Do not lift the appliance on your own.

If this appliance is not correctly installed in a washer-dryer stack, the installed appliance may fall.

- ▶ Only stack the dryer on a washing machine using the connection kit from the dryer manufacturer. No other installation method is permitted.
- ▶ Do not install the appliance in a washer-dryer stack if the dryer manufacturer does not offer a suitable connection kit.
- ▶ Do not install appliances from different manufacturers and with varying depths and widths in a washer-dryer stack.
- ▶ Do not install a washer-dryer stack on a platform; the appliances may tip over.

**⚠ WARNING – Risk of suffocation!**

Children may put packaging material over their heads or wrap themselves up in it and suffocate.

- ▶ Keep packaging material away from children.
- ▶ Do not let children play with packaging material.

**⚠ CAUTION – Risk of injury!**

The appliance may vibrate or move when in use.

- ▶ Place the appliance on a clean, even, solid surface.
- ▶ Align the appliance using the appliance feet and a spirit level.

If hoses and power cords have been laid incorrectly, this causes a tripping hazard.

- ▶ Lay hoses and power cords in such a way that there is no risk of tripping.

If the appliance is moved by holding onto protruding components, such as the appliance door, the parts may break off.

- ▶ Do not move the appliance by holding onto protruding parts.

**⚠ CAUTION – Risk of cutting!**

Touching sharp edges on the appliance may lead to cuts.

- ▶ Do not touch the sharp edges on the appliance.
- ▶ Wear protective gloves when installing and transporting the appliance.

## 1.5 Safe use

### **⚠ WARNING – Risk of electric shock!**

If the appliance or the power cord is damaged, this is dangerous.

- ▶ Never operate a damaged appliance.
- ▶ Never pull on the power cord to unplug the appliance. Always unplug the appliance at the mains.
- ▶ If the appliance or the power cord is damaged, immediately unplug the power cord or switch off the fuse in the fuse box and turn off the water tap.
- ▶ Call customer service. → *Page 35*

An ingress of moisture can cause an electric shock.

- ▶ Only use the appliance in enclosed spaces.
- ▶ Never expose the appliance to intense heat or humidity.
- ▶ Do not use steam- or high-pressure cleaners, hoses or sprays to clean the appliance.

### **⚠ WARNING – Risk of harm to health!**

Children can lock themselves in the appliance, thereby putting their lives at risk.

- ▶ The appliance must not be set up behind a lockable door, a sliding door or a door with a hinge on the side opposite to the appliance, which prevents appliance from opening fully.
- ▶ With redundant appliances, unplug the power cord. Then cut through the cord and damage the lock on the appliance door beyond repair so that the appliance door will no longer close.

When spinning larger, waterproof items of laundry, imbalances may arise and lead to injuries.

- ▶ Do not wash and spin larger items of laundry, such as blankets or mattress covers, in the appliance.

### **⚠ WARNING – Risk of suffocation!**

Children may breathe in or swallow small parts, causing them to suffocate.

- ▶ Keep small parts away from children.
- ▶ Do not let children play with small parts.

**⚠ WARNING – Risk of poisoning!**

Detergents and care products may result in poisoning if consumed.

- ▶ If accidentally swallowed, seek medical advice.
- ▶ Keep detergents and care products out of the reach of children.

**⚠ WARNING – Risk of explosion!**

Laundry that has been pretreated with flammable cleaning agents that contain solvents may cause an explosion in the appliance.

- ▶ Rinse pretreated laundry thoroughly with water before washing.

**⚠ CAUTION – Risk of injury!**

The covering plate may break if you stand on or climb onto the appliance.

- ▶ Do not stand on or climb onto the appliance.

The appliance may tip over if you sit on or lean against the open door.

- ▶ Do not sit on or lean against the appliance door.
- ▶ Do not place any objects on the appliance door.

Reaching into the drum while it is still turning may cause hand injuries.

- ▶ Wait for the drum to come to a complete stop before reaching inside.

**⚠ CAUTION – Risk of scalding!**

When you wash at high temperatures, the detergent solution gets hot.

- ▶ Do not touch the hot detergent solution.

**⚠ CAUTION – Risk of chemical burns!**

If the detergent drawer is opened, detergent and care products may spray out from the appliance.

Contact with eyes or skin may cause irritation.

- ▶ Rinse eyes and/or skin thoroughly with clean water if they come into contact with detergents or care products.
- ▶ If accidentally swallowed, seek medical advice.
- ▶ Keep detergents and care products out of the reach of children.

## 1.6 Safe cleaning and maintenance

### **⚠ WARNING – Risk of electric shock!**

Improper repairs are dangerous.

- ▶ Never make any technical modifications to the appliance or its features.
- ▶ Repairs to the appliance should only be carried out by trained specialist staff.
- ▶ Only use genuine spare parts when repairing the appliance.
- ▶ If the power cord of this appliance is damaged, it must be replaced by the manufacturer, the manufacturer's Customer Service or a similarly qualified person in order to prevent any risk.

An ingress of moisture can cause an electric shock.

- ▶ Before cleaning, pull out the mains plug or switch off the fuse in the fuse box.
- ▶ Do not use steam- or high-pressure cleaners, hoses or sprays to clean the appliance.

### **⚠ WARNING – Risk of injury!**

The use of non-original spare parts and non-original accessories is dangerous.

- ▶ Only use the manufacturer's original spare parts and original accessories.

### **⚠ WARNING – Risk of poisoning!**

Poisonous fumes may be given off if you use cleaning agents that contain solvents.

- ▶ Do not use cleaning agents that contain solvents.

---

## 2 Preventing material damage

### **ATTENTION**

The functionality of the appliance may be impaired if you use the wrong quantity of fabric softener, detergent, care product or cleaning agent.

- ▶ Follow the dosage recommendations from the manufacturer.

Exceeding the maximum load capacity impairs the function of the appliance.

- ▶ Observe the maximum load capacity for each programme and do not exceed it. → *Page 20*

The appliance is secured for transportation using transit bolts.

Transit bolts which have not been removed may result in material damage and damage to the appliance.

- ▶ Before starting up the appliance, remove the transit bolts completely and keep them in a safe place.
- ▶ Before transport, fit the transit bolts fully in order to prevent damage in transit.

Material damage may be caused if the water inlet hose is connected incorrectly.

- ▶ Tighten the screw connections on the water inlet until they are hand-tight.
- ▶ Connect the water inlet hose directly to the water tap, without any additional connecting elements such as adapters, extensions or valves.
- ▶ Ensure that the inner diameter of the water tap is at least 17 mm.
- ▶ Make sure that the length of the thread on the connection to the water tap is at least 10 mm.

If the water pressure is too high or too low, the appliance may not be able to operate properly.

- ▶ Ensure that the water pressure in the water supply system is at least 100 kPa (1 bar) and max. 1000 kPa (10 bar).
- ▶ If the water pressure exceeds the maximum value specified, a pressure-reducing valve must be installed between the water connection and the hose set of the appliance.
- ▶ Do not connect the appliance to the mixer tap of an unpressurised hot-water boiler.

Modified or damaged water hoses may result in material damage and damage to the appliance.

- ▶ Never kink, crush, modify or cut through water hoses.
- ▶ Only use the water hoses supplied with the appliance or genuine spare hoses.
- ▶ Never re-use water hoses that have been used before.

Operating the appliance using water that is dirty or too hot may lead to material damage and damage to the appliance.

- ▶ Only operate the appliance with cold mains water.

Unsuitable cleaning products may damage the surfaces of the appliance.

- ▶ Do not use harsh or abrasive detergents.
- ▶ Do not use cleaning products with a high alcohol content.
- ▶ Do not use hard scouring pads or cleaning sponges.
- ▶ Clean the appliance with nothing but water and a soft, damp cloth.
- ▶ Remove all detergent residue, spray residue or other residues immediately if they come into contact with the appliance.

---

## **3 Environmental protection and saving energy**

### **3.1 Disposing of packaging**

The packaging materials are environmentally compatible and can be recycled.

- ▶ Sort the individual components by type and dispose of them separately.

### 3.2 Save energy and conserve resources

If you follow these instructions, your appliance will use less electricity and less water.

- Choose programs with low temperatures and longer wash times and use maximum load capacity.  
→ *Page 20*
- Add detergent based on the laundry's degree of soiling.
- Reduce the washing temperature for lightly and normally soiled laundry.
- Set the maximum spin speed if you want to dry the laundry in the tumble dryer afterwards.
- Wash the laundry without prewash.

### 3.3 Energy saving mode

If you do not use the appliance for a brief period, it automatically switches to energy-saving mode.

Energy-saving mode ends when you use the appliance again.

If you do not use the appliance for an extended period, it switches itself off.

---

## 4 Installation and connection

### 4.1 Unpacking the appliance

#### ATTENTION

Objects remaining in the drum that are not designed for operation with the appliance may cause material damage and damage to the appliance.

- ▶ Remove these objects, along with all supplied accessories, from the drum before starting the appliance.

1. Remove any packaging and protective covers completely from the appliance.  
→ *"Disposing of packaging", Page 9*
2. Check the appliance for visible damage.
3. Open the door. → *Page 25*
4. Remove any accessories from the drum.
5. Close the door.

### 4.2 Contents of package

After unpacking all parts, check for any damage in transit and completeness of the delivery.

#### ATTENTION

If the appliance is operated with incomplete or defective accessories, the appliance may not be able to operate properly, or this may result in material damage or damage to the appliance.

- ▶ Do not operate the appliance with incomplete or defective accessories.
- ▶ Replace the accessories in question before operating the appliance.  
→ *"Accessories", Page 23*

**Note:** The appliance has undergone a function test at the factory. This may cause water stains in the appliance, which the first wash cycle removes.

The delivery consists of the following:

- Washing machine
- Accompanying documents
- Transit bolts → *Page 12*
- Cover caps
- Water inlet hose → *Page 12*

### 4.3 Requirements for the installation location

**⚠ WARNING**

**Risk of electric shock!**

The appliance contains live parts. Touching live parts is dangerous.

- ▶ Do not operate the appliance without a cover cap.

**⚠ WARNING**

**Risk of injury!**

When using the appliance on a base, the appliance may tip over.

- ▶ Always secure the feet of the appliance to a base using the manufacturer's fixing brackets → *Page 23* before using the appliance for the first time.

**ATTENTION**

If residual water in the appliance freezes, this may cause damage to the appliance.

- ▶ Do not install or operate this appliance anywhere that is liable to experience frost or outdoors.

If the appliance is tilted at an angle greater than 40°, residual water may leak out of the appliance and cause material damage.

- ▶ Tilt the appliance carefully.
- ▶ Transport the appliance in an upright position.

Installation location	Requirements
-----------------------	--------------

Base



Secure the appliance with fixing brackets → *Page 23*.

Wooden joist floor

Place the appliance on a water-resistant wooden

Installation location	Requirements
-----------------------	--------------



board (minimum thickness of 30 mm) which is screwed tightly to the floor.

Kitchen unit

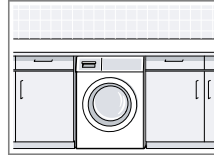

Only install the appliance underneath a continuous worktop that is securely connected to adjacent cabinets. Required niche width: 60 cm.

Against a wall

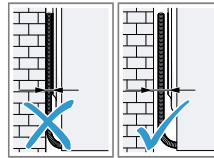

Do not trap the power cord or the hoses between the wall and the appliance.

### 4.4 Removing foam parts

To prevent transport damage, the appliance is protected with foam parts at the factory. Remove the foam parts before switching on the appliance.

**⚠ WARNING**

**Risk of injury!**

When the appliance is tilted, the appliance may tip over.

- ▶ Tilt the appliance carefully.
- ▶ Do not tilt the appliance on your own.

**ATTENTION**

If the foam material is not removed, it can cause damage to the appliance when it is operated.

- ▶ Before starting up the appliance, remove all foam parts.

## en Installation and connection

1. Tilt the appliance backwards.

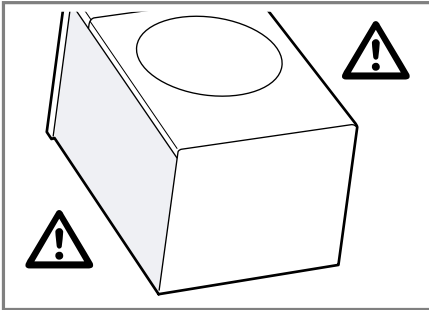

2. Remove the foam parts on the underside.

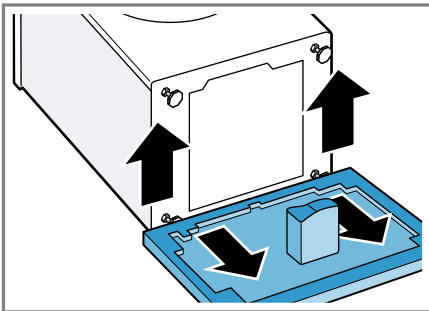

Do not dispose of the foam parts. Use the foam parts when transporting the appliance in the future.

**Note:** To insert the foam parts for transportation into the appliance, perform these steps again in the reverse order.

### 4.5 Removing the transit bolts

The appliance is secured for transportation using transit bolts on the rear of the appliance.

**Note:** Keep the transit bolt screws and the washers in a safe place for future transport.

→ "Inserting the transit bolts",  
Page 35

**Requirement:** The foam parts are removed. → Page 11

1. Pull the hose out of the holders.

2. Unscrew ① and remove ② all of the screws for the 4 transit bolts using a WAF 13 wrench.

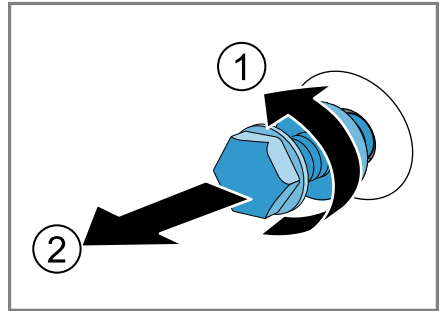

3. Remove the power cable from the holder.
4. Put on the 4 cover caps.

**Note:** To install the transit bolts to transport the appliance, perform these steps again in the reverse order.

### 4.6 Connecting the appliance

#### Connecting the water inlet hose

##### ATTENTION

Material damage may be caused if the water inlet hose is connected incorrectly.

- ▶ Tighten the screw connections on the water inlet until they are hand-tight.

1. Connect the water inlet hose.

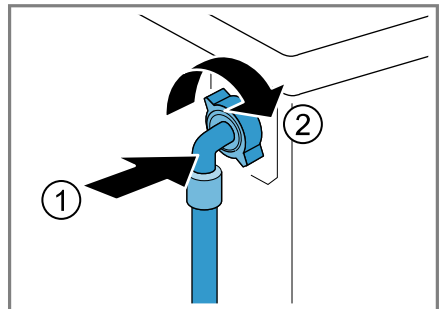

2. Connect the water inlet hose to a tap (26.4 mm = 3/4").

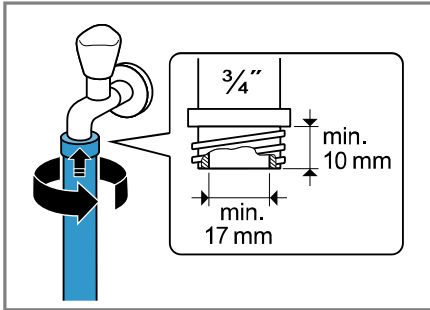

3. Open the water tap carefully and check that the connection points are tight.

### Water outlet connection types

This information is intended to help you to connect this appliance to the water outlet.

#### ATTENTION

When draining, the water outlet hose is subject to water pressure and may come loose from the installed connection point.

- ▶ Secure the water outlet hose against unintentional loosening. In the event of a blocked or covered outlet, accumulated wastewater can flow back into the appliance.
- ▶ Before operating the appliance, ensure that the wastewater drains away quickly and eliminate any blockages.

**Note:** Observe the draining heights. The draining heights are: minimum: 60 cm, maximum: 100 cm

#### Siphon

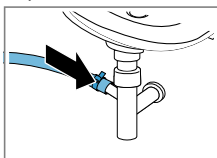

Secure the connection point with a (24–40 mm) hose clamp.

#### Sink

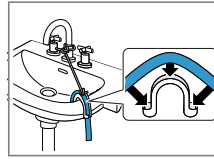

Fix and secure the water outlet hose with an elbow. → "Accessories", Page 23

#### Plastic pipe with rubber sleeve

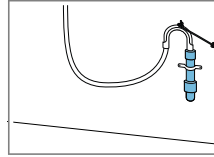

Fix and secure the water outlet hose with an elbow. → "Accessories", Page 23

### Connecting the appliance to the electricity supply

**Note:** Your electrical domestic installation for this appliance must comply with the local legal provisions and safety regulations, and should include a residual current circuit-breaker.

1. Insert the mains plug of the appliance's power cable in a socket nearby. The connection details of the appliance can be found under Technical data → Page 36.
2. Check the mains plug is inserted properly.

### 4.7 Aligning the appliance

In order to reduce noise and vibration and to prevent the appliance from moving, align the appliance correctly.

en Before using for the first time

1. Use a WAF 17 wrench to loosen the lock nuts in a clockwise direction.

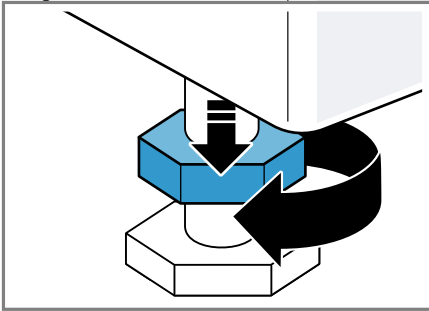

2. To align the appliance, turn the appliance feet. Check that the appliance is level using a spirit level.

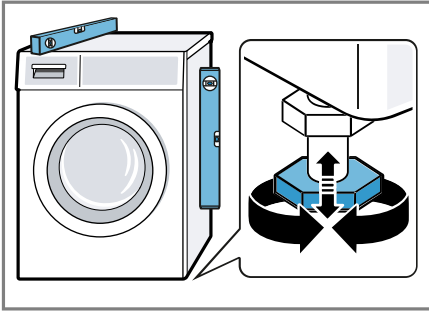

All appliance feet must stand firmly on the ground.

3. Use a WAF 17 wrench to tighten the lock nuts against the housing until they are hand-tight.

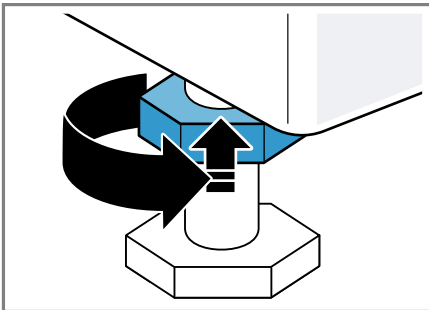

In doing so, hold the foot tight and do not adjust its height.

## 5 Before using for the first time

Prepare the appliance for use.

### 5.1 Starting an empty washing cycle

Your appliance was inspected thoroughly before leaving the factory. To remove any residual water, run the first wash cycle without any laundry.

1. Press **Off**.  
The switch-on process takes a few seconds.
2. Select the **Cottons** 90° programme or a programme for drum cleaning. → *Page 27*
3. Close the door.
4. Pull out the detergent drawer.
5. Pour approx. 1 litre of tap water into compartment II.

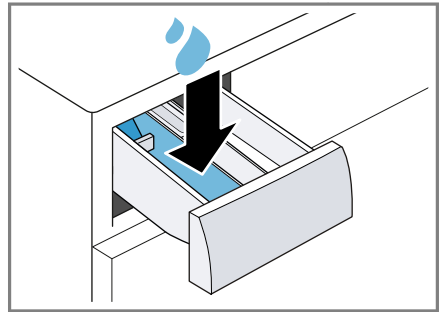

6. Add washing powder containing oxygen bleach to compartment II.

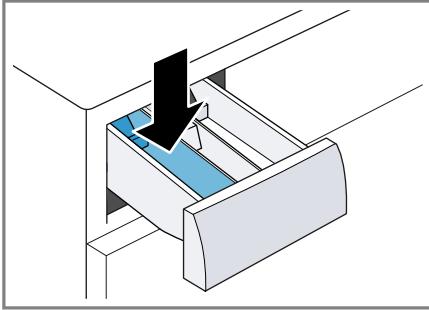

To prevent foaming, use only half of the amount of detergent recommended by the detergent manufacturer for light soiling. Do not use detergent suitable for woollens or delicates.

7. Push in the detergent drawer.  
 8. Start the programme. → *Page 25*  
 9. Start the first wash cycle or press **Off** to switch off the appliance.  
 → *"Basic operation", Page 24*

## 6 Familiarising yourself with your appliance

### 6.1 Appliance

You can find an overview of the parts of your appliance here.

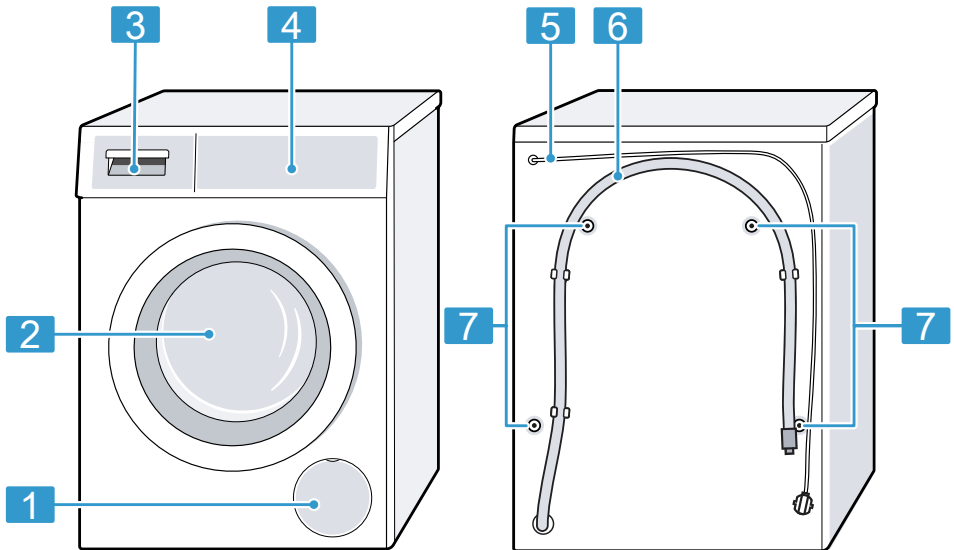

On certain models, specific details such as the colour and shape may differ from those pictured.

en Familiarising yourself with your appliance

- 
- 1 Maintenance flap for the drain pump → *Page 28*

---

  - 2 Door → *Page 25*

---

  - 3 Detergent drawer → *Page 16*

---

- 
- 4 Control panel → *Page 17*

---

  - 5 Power cord → *Page 13*

---

  - 6 Water outlet hose → *Page 13*

---

  - 7 Transit bolts → *Page 12*

---

## 6.2 Detergent drawer

**Note:** Observe the manufacturer's instructions on the use and dosage of the detergent and care product and the information in the programme descriptions.

- 
- 1 Compartment II: Detergent for the main wash

---

  - 2 Compartment ⌘: Fabric softener

---

  - 3 Compartment I: Detergent for prewash

---

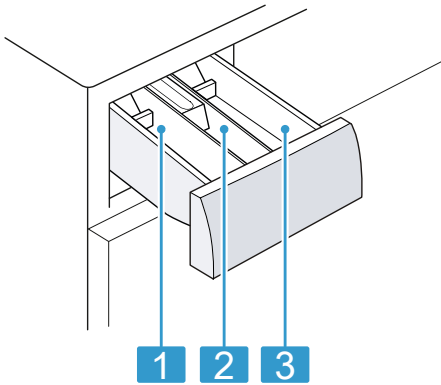

## 6.3 Control panel

You can use the control panel to configure all functions of your appliance and to obtain information about the operating status.

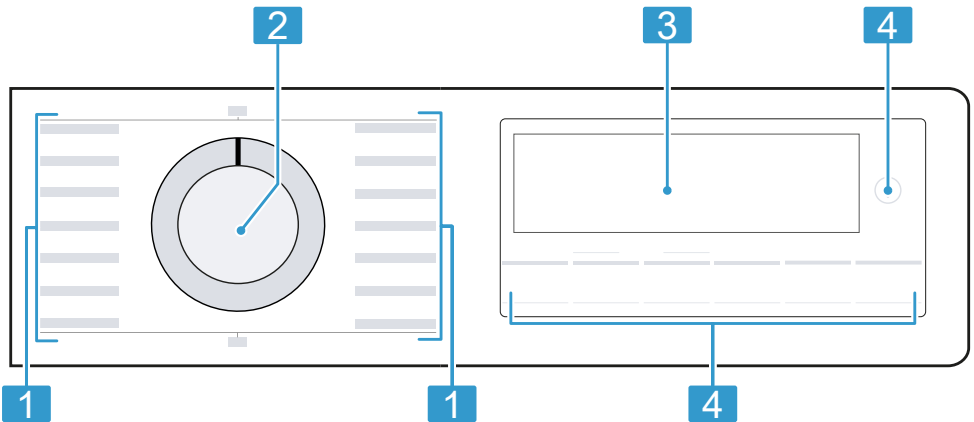

**1** Programmes → *Page 20*

**3** Display → *Page 17*

**2** Programme selector  
→ *Page 24*







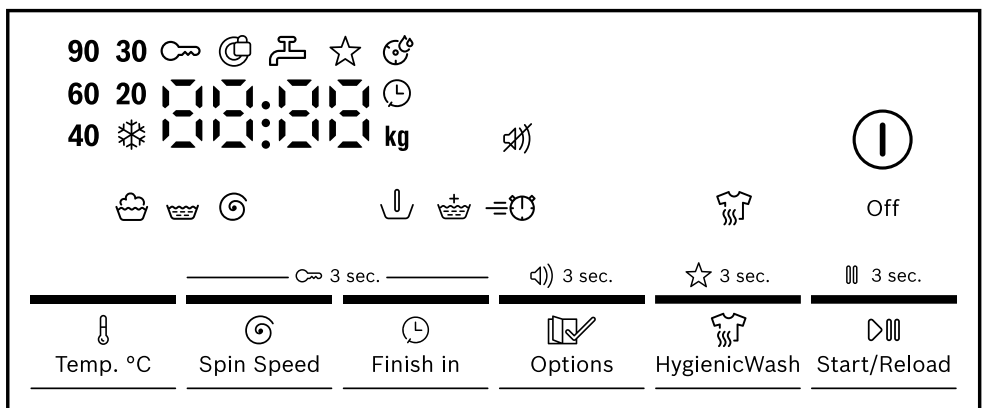









**4** Buttons → *Page 18*

## 7 Display

The display shows the current settings, options or relevant information. Depending on the programme status, the display shows some information in the **88:88** area, e.g. **E nd**.

















Example: Display

Display	Description
00:40 <sup>1</sup>	Expected programme duration or programme time remaining in hours and minutes.
 10 h <sup>1</sup>	Programme end time → <i>Page 19</i>
00:00 - 1300	Set spin speed in rpm. → <i>Page 19</i> 00:00: No spin cycle, draining only
 - 90	Set temperature in °C. → <i>Page 19</i>  (cold)
	Programme status: Washing
	Programme status: Rinsing
	Programme status: Spinning
End	Programme status: Programme end
	<ul style="list-style-type: none"> <li>■ Lights up: The childproof lock is activated.</li> <li>■ Flashes: The childproof lock is activated and the appliance has been operated. → <i>Page 26</i></li> </ul>
	Additional rinse cycle is activated.
	Prewash is activated.
	Shortened programme duration is activated.
	Save a programme.
	Flashes: Drum cleaning is required. Run the  Drum Clean programme for cleaning and caring for the drum and the outer tub. → <i>Page 27</i>
	Hygienic pretreatment and care of durable fabrics is activated. → <i>Page 19</i>
	Operating signals and notification signals are deactivated. → <i>Page 19</i>
	<ul style="list-style-type: none"> <li>■ Lights up: The door is locked and cannot be opened. <ul style="list-style-type: none"> <li>- To add laundry, unlock the door. → <i>Page 25</i></li> <li>- To open the door, cancel the programme. → <i>Page 26</i></li> </ul> </li> <li>■ Off: The door is unlocked and can be opened.</li> </ul>
	<ul style="list-style-type: none"> <li>■ No water pressure. → <i>Page 31</i></li> <li>■ The water pressure from the tap is too low.</li> </ul>

## 8 Buttons

The selection of programme settings depends on the programme that is set.







<sup>1</sup> Example









<b>Button</b>	<b>Description</b>
 Start/Reload	Start or pause the programme.
 3 sec.	Depending on the programme status, if you press and hold the button for approx. 3 seconds you can: <ul style="list-style-type: none"> <li>■ Adding laundry → <i>Page 25</i></li> <li>■ Adjust the programme settings</li> </ul>
 Hygienic Wash	Activate or deactivate hygienic pretreatment and care of durable fabrics. The fabrics are pre-treated with hot steam. After the fabrics have been pre-treated, they are washed at normal temperatures. <b>Note:</b> If you activate the setting, the set programme's maximum load capacity is reduced by half.
 Finish In	Set the programme end time. The programme duration is already included in the set number of hours. Once the programme has started, the programme duration is displayed.
 Temp. °C	Adjust the temperature.
 Spin Speed	Adjust the spin speed or deactivate the spin cycle. If 00:00 is selected, the water is drained and the spin cycle is deactivated. The laundry stays wet inside the drum.
 3 sec.	Activate or deactivate operating signals and information signals.
 Off	Switch the appliance on or off.
 3 sec.	Activate or deactivate the childproof lock. → <i>Page 26</i>
 Options	 : Activate or deactivate prewash, e.g. for washing heavily soiled laundry. Add the detergent for the prewash in compartment I and the detergent for the main wash in compartment II of the detergent drawer. → " <i>Detergent drawer</i> ", <i>Page 16</i>  : Activate or deactivate an additional rinse cycle. Recommended for particularly sensitive skin or in regions with very soft water.  : Activate or deactivate a shortened programme duration. The energy consumption increases. The washing result is not affected by this.
 3 sec.	Save your individual programme settings. → <i>Page 24</i>

## 9 Programmes

### Notes

- The laundry's care labels provide you with additional information about programme selection.  
→ "Care symbols on the care labels", Page 24
- The programme's temperature setting guarantees that the recommended temperature on the care label is not exceeded. The temperature that is reached in the appliance may differ from the set temperature. This means that the best possible washing performance is achieved with optimal energy efficiency.

Programme	Description	Max. load (kg)
Cottons 	Wash hard-wearing items made from cotton or linen. Programme setting: <ul style="list-style-type: none"> <li>▪ Max. 90 °C</li> <li>▪ Max. 1300 rpm</li> </ul>	10.0
Intensive 	Wash items made from cotton or linen. <b>Note:</b> Fabrics which can be washed from 40 °C  up to 60 °C  as per the care symbol can be washed together. The washing performance corresponds to the best possible washing performance class according to the legal requirements. For this programme, the washing temperature is automatically adjusted depending on the load size, in order to achieve the best possible energy efficiency with the best possible washing result. You cannot change the washing temperature. The maximum spin speed is 1300 rpm.	10.0
 Kidsweat	Wash hard-wearing items made from cotton or linen. Suitable for children's clothing. Programme setting: <ul style="list-style-type: none"> <li>▪ max. 90 °C</li> <li>▪ max. 1200 rpm</li> </ul>	10.0
 Night Wash	Wash items made from cotton, linen or synthetic fabrics. Suitable for quiet washing at night. The signal at the end of the programme is deactivated and a reduced final spin speed set by default.	10.0

Programme	Description	Max. load (kg)
	Programme setting: <ul style="list-style-type: none"> <li>■ max. 90 °C</li> <li>■ max. 800 rpm</li> </ul>	
Easy Care 	Wash items made from synthetic fabrics. Programme setting: <ul style="list-style-type: none"> <li>■ Max. 60 °C</li> <li>■ Max. 1200 rpm</li> </ul>	5.0
Mix 	Wash items made from cotton, linen or synthetic fabrics. Suitable for lightly soiled laundry. Programme setting: <ul style="list-style-type: none"> <li>■ Max. 90 °C</li> <li>■ Max. 1300 rpm</li> </ul>	5.0
Delicates/Silk 	Wash delicate, washable items made from silk, viscose and synthetic fabrics. Use a detergent that is suitable for delicates or silk. <b>Note:</b> Wash especially delicate items or items with hooks, eyelets or clips in a mesh laundry bag. <b>Tip:</b> Gently cleaning the laundry reduces abrasion of textile fibres and microplastic fibres. Programme setting: <ul style="list-style-type: none"> <li>■ Max. 30 °C</li> <li>■ Max. 800 rpm</li> </ul>	2.0
 Wool 	Hand- or machine-washable items that are made from wool or contain wool. To prevent the laundry from shrinking, the drum moves the items very gently with long pauses. Use a detergent that is suitable for wool. Programme setting: <ul style="list-style-type: none"> <li>■ Max. 30 °C</li> <li>■ Max. 800 rpm</li> </ul>	2.0
Rinse/Spin  	Rinse and then spin the laundry, and drain the water. Programme setting: Max. 1300 rpm	–
 Spin/Drain 	Spin the laundry and drain the water. Programme setting: Max. 1300 rpm	–
☆ Memory	Set your saved programme with individual programme settings.	

Programme	Description	Max. load (kg)
Hygiene 65°	<p>Wash hard-wearing items made from cotton or linen. Suitable for allergy sufferers and for strict hygiene requirements.</p> <p><b>Note:</b> Once the set temperature has been reached, it remains constant throughout the entire washing process.</p> <p>Programme setting:</p> <ul style="list-style-type: none"> <li>■ Max. 60 °C</li> <li>■ Max. 1300 rpm</li> </ul>	5.0
Shirts	<p>Wash non-iron shirts and blouses made from cotton, linen or synthetic fabrics.</p> <p><b>Note:</b> Use the Delicates/Silk programme to wash shirts and blouses made from silk or delicate fabrics.</p> <p>Programme setting:</p> <ul style="list-style-type: none"> <li>■ Max. 60 °C</li> <li>■ Max. 800 rpm</li> </ul>	2.0
Sportswear	<p>Wash sports and leisure items made from synthetic fabrics.</p> <p>Use a detergent that is suitable for sports items. Do not use fabric softener.</p> <p><b>Tip:</b> Use the Easy Care programme to wash heavily soiled laundry.</p> <p>Programme setting:</p> <ul style="list-style-type: none"> <li>■ Max. 40 °C</li> <li>■ Max. 1300 rpm</li> </ul>	2.0
Drum Clean	<p>Clean and care for the drum. → <i>Page 27</i></p> <p>Use this programme in the following cases:</p> <ul style="list-style-type: none"> <li>■ Before using the appliance for the first time</li> <li>■ If you regularly wash at temperatures of 40 °C or lower</li> <li>■ After a prolonged period of non-use</li> </ul> <p>Use washing powder containing oxygen bleach. Add the washing powder containing oxygen bleach to compartment II for the main wash. → <i>Page 16</i> Halve the amount of detergent to avoid foaming. Do not use fabric softener.</p>	– <sup>1</sup>

<sup>1</sup> Washing not possible

Programme	Description	Max. load (kg)
	Do not use liquid detergent or detergent that is intended for woollens or delicates. <b>Note:</b> The drum cleaning indicator flashes to remind you if you have not used a programme at 60 °C or higher for a long time.	
☉ Quick 15'	Wash items made from cotton or synthetic fabrics. Short programme for small items of lightly soiled laundry. Programme setting: <ul style="list-style-type: none"> <li>▪ Max. 30 °C</li> <li>▪ Max. 800 rpm</li> </ul>	2.0

## 10 Accessories

Use original accessories. These have been made especially for your appliance.

	Use	Order number
Water inlet hose extension	Extend the water inlet hose for cold water or AquaStop (approx. 2.50 m).	WZ10130
Fixing brackets	Improves the stability of the appliance.	WX975600
Elbow	Secure the water outlet hose in place.	00655300

## 11 Laundry

### 11.1 Preparing the laundry

#### ATTENTION

Objects remaining in the laundry may damage the laundry and the drum.

- ▶ Remove all items from any pockets in your laundry before using the appliance.

#### Note

The appliance and fabrics are protected when you prepare your laundry.

- Brush off sand and soil
- Sort the laundry according to colour and textiles and observe the care labels





- Close all zips, hook and loop fasteners, hooks and eyes
- Tie cloth belts, cloth straps and cords together
- Remove curtain fittings and lead strips
- Wash small or particularly delicate items in a mesh washing bag
- Wash large and small items of laundry together
- Wash laundry with fresh stains immediately
- Pretreat laundry with dried stains and wash several times
- Load the laundry unfolded into the drum

## en Detergents and care products

- Before loading the drum, any laundry that has been pre-treated with chlorine bleach should be rinsed several times

### 11.2 Care symbols on the care labels

#### Washing care symbols

Symbol	Recommended programme
	Cottons (normal)
	Easy Care (gentle)
	Delicates/Silk for washing by hand (particularly gentle)
	Woollens (hand wash)
	(not suitable for machine-washing)

## 12 Detergents and care products

You can protect your appliance and your laundry by selecting and using the correct detergents and care products.

The manufacturer's instructions for use and dosage can be found on the packaging.

#### Notes

- When using liquid detergents, only use liquid detergents that are self-flowing
- Do not mix different liquid detergents
- Do not mix detergent and fabric softener
- Do not use products that have expired or are highly congealed

- Do not use products containing solvents, caustic agents or volatile substances
- Do not use chlorine bleach
- Do not use dyes regularly as fixing salt can damage stainless steel
- Do not use color-bleaching agents in the appliance

## 13 Basic operation

### 13.1 Switching on the appliance

**Requirement:** The appliance has been correctly installed and connected. → *Page 10*

- ▶ Press  **Off**.

The switch-on process takes a few seconds.

**Note:** The lighting for the drum goes out automatically.

### 13.2 Setting a programme

1. Turn the programme selector and set the required programme.  
→ *Page 20*
2. If required, adjust the programme settings. → *Page 18*  
The programme settings are not saved permanently for the programme.

### 13.3 Saving programme settings

You can save your individual programme settings as favourites.

**Requirement:** A programme is set.  
→ *Page 24*

- ▶ Press and hold ☆ **3 sec.** for approx. 3 seconds.

**Note:** To overwrite the saved programme, repeat the steps above.

### 13.4 Opening the door

1. Grip under the door handle and pull on the door.

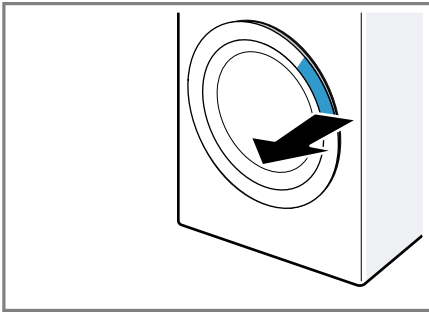

2. Open the door.

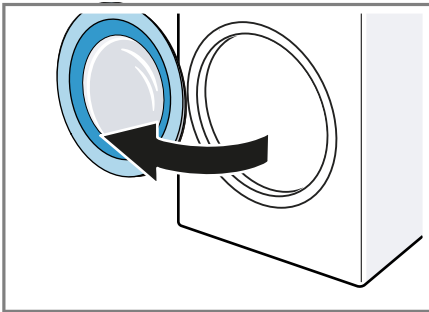

### 13.5 Loading laundry

**Note:** To prevent creasing, note the maximum load for the programmes.  
→ *Page 20*

#### Requirements

- The laundry is prepared and sorted. → *Page 23*
  - The drum is empty.
1. Open the door. → *Page 25*
  2. Place the laundry in the drum.
  3. Close the door.  
Ensure that there is no laundry trapped in the door.

### 13.6 Adding detergent and care product

**Note:** Observe the information about detergents and care products  
→ *Page 24*.

1. Pull out the detergent drawer.
2. Pour in the detergent.  
→ *"Detergent drawer", Page 16*
3. If required, add the care product.
4. Push in the detergent drawer.

### 13.7 Starting the programme

#### Requirements

- A programme is set. → *Page 24*
  - The door is closed.
- ▶ Press **Start/Reload**.
- ✓ The display shows the programme duration or the programme end time.
  - ✓ After the programme has ended, the display shows: "End".

### 13.8 Soaking laundry

**Note:** No additional detergent is required for soaking. The appliance uses the filled detergent for soaking and washing.

#### Requirements

- The laundry is placed in the appliance. → *Page 25*
  - A programme has started.  
→ *Page 25*
1. Press **Start/Reload** approx. 10 minutes after the programme start.  
The programme pauses and the laundry can soak.
  2. Press **Start/Reload** after the required soaking time.

### 13.9 Adding laundry

After the programme starts, you can remove or add laundry depending on the programme status.

## en Childproof lock

1. Press and hold  **3 sec.** for approx. 3 seconds.  
During the washing cycle, the appliance pauses.  
**Note:** If you want to add laundry, follow the instructions on the display. → *Page 18*
2. Open the door. → *Page 25*
3. Add or remove laundry.
4. Close the door.
5. Start the programme. → *Page 25*

### 13.10 Cancelling the programme

1. Press  **Off**.  
✓ The appliance switches off.
2. Switch on the appliance.  
→ *Page 24*  
To open the door, wait for approx. 1 minute.
3. Open the door. → *Page 25*  
The appliance door remains locked for safety reasons if the temperature and water levels are high.
  - If the temperature is high, start the programme.
  - If the water level is high, start the **Spin** programme or select a suitable programme for draining.  
→ *Page 20*
4. Remove the laundry. → *Page 26*

### 13.11 Unloading the laundry

1. Open the door. → *Page 25*
2. Remove the laundry from the drum.

### 13.12 Switching off the appliance

1. Press  **Off**.
2. Turn off the tap.
3. Cleaning the rubber gasket.  
→ *Page 30*



**Note:** Leave the appliance door and the detergent drawer open to dry.

---

## 14 Childproof lock



Secure your appliance against being operated unintentionally using the controls.

### 14.1 Activating the childproof lock

- ▶ Press on both  **3 sec.** buttons for approx. 3 seconds.
- ✓ During the activation, "CL" flashes on the display.
- ✓ The display shows .
- ✓ The control elements are locked.
- ✓ The childproof lock remains active even after the appliance has been switched off and in the event of a power cut.

### 14.2 Deactivating the childproof lock

**Requirement:** To deactivate the childproof lock, the appliance must be switched on.

- ▶ Press on both  **3 sec.** buttons for approx. three seconds.
- ✓  goes out on the display.

---

## 15 Cleaning and servicing

### ATTENTION

Heavy, sharp or rough objects may damage the appliance.

- ▶ Do not use hard or sharp objects, abrasive cleaning products or steel wool for cleaning.
- ▶ Clean the appliance using only water and a soft cloth.

## 15.1 Cleaning the drum

Clean the drum if you have carried out 20 washing cycles at a temperature of 40 °C or lower, if ☼ flashes, or if you have not used the appliance for a prolonged period, but at least once a year.

### ⚠ CAUTION

#### Risk of injury!

Permanently washing at low temperatures and a lack of ventilation for the appliance may damage the drum and cause injury.

- ▶ Regularly run a programme for cleaning the drum or wash at temperatures of at least 60 °C.
- ▶ Leave the appliance to dry after every operation with the door open, and leave the detergent drawer to dry.
- ▶ Run the ☼ **Drum Clean** programme without laundry but with washing powder that contains oxygen bleach or a cleaning agent for caring for the inside of the appliance.

## 15.2 Cleaning the detergent drawer

**Note:** Scan the QR code to see an animation of the process.



1. Pull out the detergent drawer.

2. Press down on the insert and remove the detergent drawer.

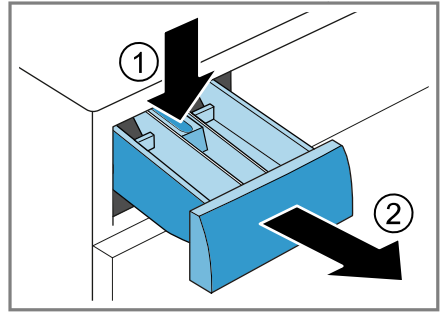

3. Pull out the insert upwards.

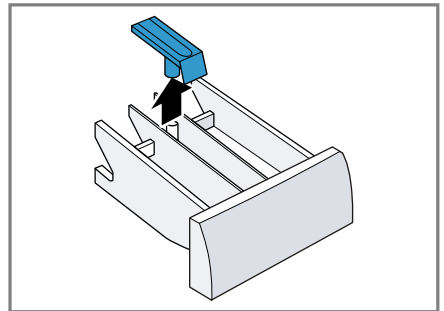

4. Clean the detergent drawer and insert with water and a brush, and then dry them.

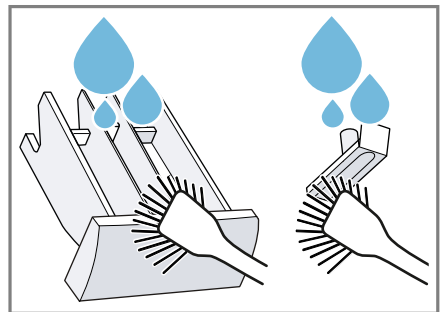

5. Fit the insert and click it into place.

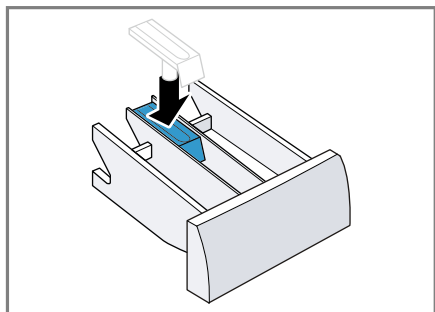

6. Clean the opening for the detergent drawer.

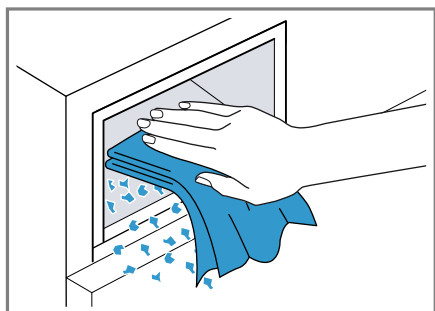

7. Push in the detergent drawer.

### 15.3 Cleaning the drain pump

Clean the drain pump regularly, at least once a year, as well as in the event of faults, e.g. blockages or rattling noises.

**Note:** Scan the QR code to see an animation of the process. Observe the following safety instructions before you start the animation.



### Emptying the drain pump

1. Turn off the tap.

2. Switch off the appliance.  
→ Page 26
3. Disconnect the appliance's mains plug from the power supply.
4. Open the maintenance flap.

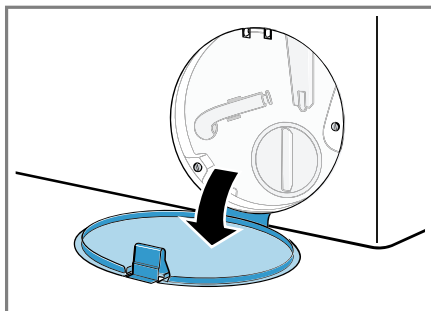

5. Slide a suitable receptacle under the opening for draining the detergent solution.

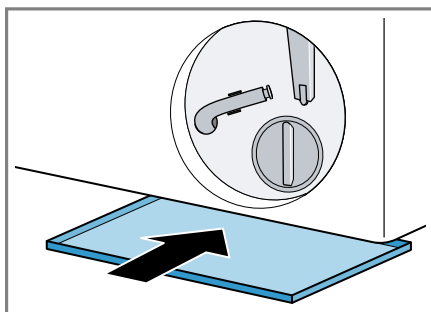

6. Take the drain hose out of the holder.

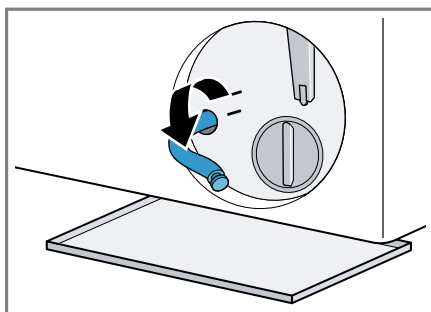

7. ⚠ **CAUTION – Risk of scalding!**  
When you wash at high temperat-

ures, the detergent solution gets hot.

- ▶ Do not touch the hot detergent solution.

To allow the detergent solution to flow out into the container, remove the sealing cap.

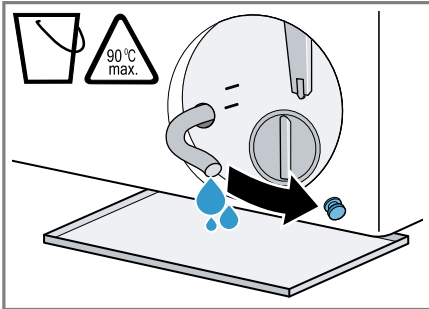

8. Once emptied, press firmly on the locking cap.

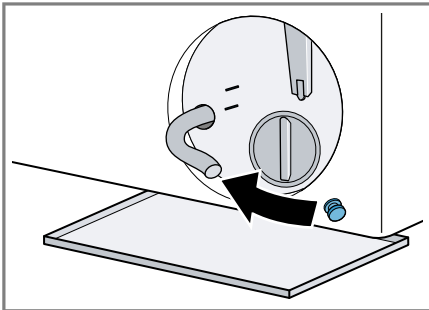

9. Insert the drain hose into the holder.

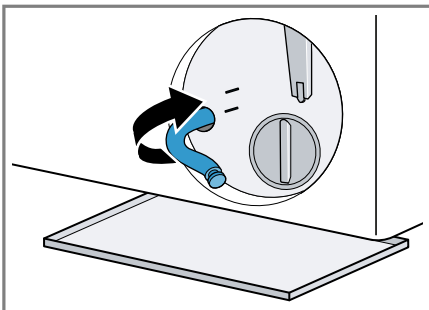

## Cleaning the drain pump

**Requirement:** The drain pump is empty. → Page 28

1. Since water may remain in the drain pump, unscrew the pump cap carefully.

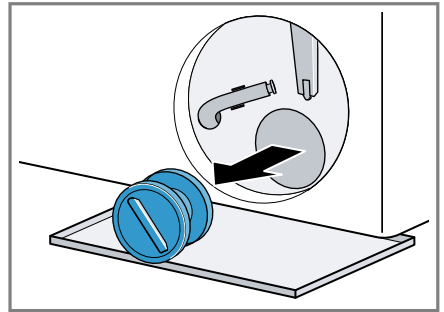

2. Clean the interior, the thread on the pump cap and the pump housing.

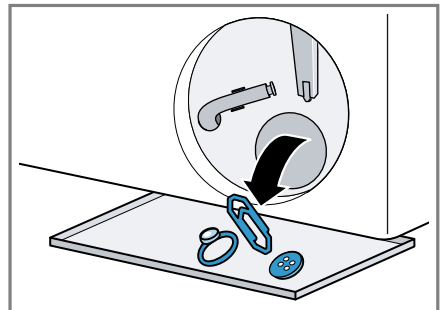

3. Ensure that the impeller in the drain pump can rotate.
4. Insert the pump cap.

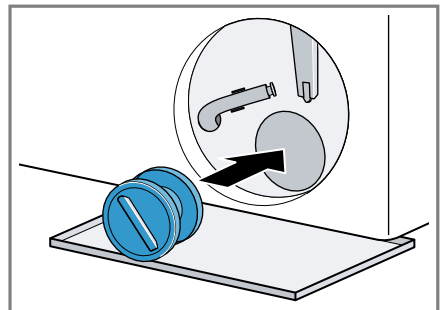

## en Troubleshooting

5. Screw the pump cap as far as it will go.

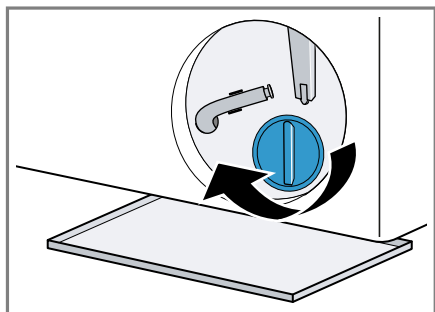

6. Empty the receptacle with the detergent solution.
7. Close the service flap.

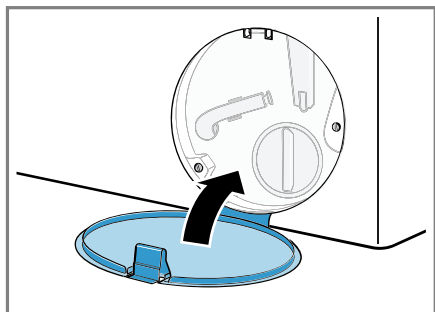

### Before the next wash

To prevent unused detergent from flowing straight into the outlet in the next wash, run a suitable programme

for draining after you have emptied the drain pump.

1. Open the water tap.
2. Insert the mains plug.
3. Switch on the appliance.
4. Pour 1 litre of water into compartment II.
5. Select a suitable programme for draining. → *Page 20*

### 15.4 Cleaning the rubber gasket

Clean the rubber gasket regularly.

1. Open the door. → *Page 25*
2. Remove any foreign objects and fluff from the rubber gasket.

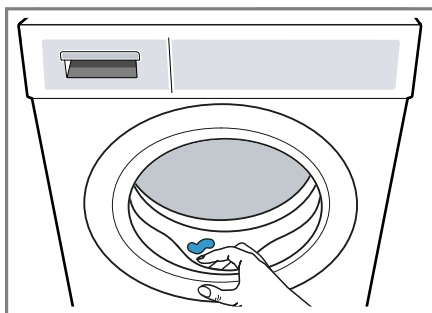

3. Clean the outside and the inside of the rubber gasket with a damp cloth and wipe dry.

---

## 16 Troubleshooting

You can rectify minor faults on your appliance yourself. Read the troubleshooting information before contacting after-sales service. This will avoid unnecessary costs.



### **WARNING**



#### **Risk of electric shock!**

Improper repairs are dangerous.

- ▶ Never make any technical modifications to the appliance or its features.
- ▶ Repairs to the appliance should only be carried out by trained specialist staff.
- ▶ Only use genuine spare parts when repairing the appliance.

- ▶ If the power cord of this appliance is damaged, it must be replaced by the manufacturer, the manufacturer's Customer Service or a similarly qualified person in order to prevent any risk.

<b>Fault</b>	<b>Cause and troubleshooting</b>
E:21 The detergent solution is not being pumped out.	<p>The water outlet hose is connected too high, is kinked or trapped, or has been extended impermissibly.</p> <ul style="list-style-type: none"> <li>▶ Check the installation of the water outlet hose. → <i>Page 12</i></li> </ul> <hr/> <p>Drain pipe or water outlet hose is blocked.</p> <ul style="list-style-type: none"> <li>▶ Clean the drain pipe and the water outlet hose.</li> </ul> <hr/> <p>The drain pump is blocked or the pump cover is not installed correctly.</p> <ul style="list-style-type: none"> <li>▶ Check that the pump cover is installed correctly. → <i>Page 28</i></li> <li>▶ Clean the drain pump. → <i>Page 28</i></li> </ul> <hr/> <p>Detergent dosage is too high.</p> <ul style="list-style-type: none"> <li>▶ Reduce the amount of detergent for the next washing cycle with the same load.</li> </ul>
E:10 / 	<p>The tap is turned off.</p> <ul style="list-style-type: none"> <li>▶ Turn on the tap.</li> </ul> <hr/> <p>The water inlet hose is kinked or jammed.</p> <ul style="list-style-type: none"> <li>▶ Check the installation of the water inlet hose. → <i>Page 12</i></li> </ul> <hr/> <p>The filters in the water inflow are blocked.</p> <ul style="list-style-type: none"> <li>▶ Clean the filters in the water inflow.</li> </ul> <p>Scan the QR code to see an animation of the process.</p> <div data-bbox="367 975 510 1121" style="text-align: center;">  </div>
	<p>The water pressure is low.</p> <ul style="list-style-type: none"> <li>▶ Check whether the tap has sufficient water pressure.</li> </ul>
All other error codes.	<p>Malfunction</p> <ol style="list-style-type: none"> <li>1. Restart the appliance.</li> <li>2. If the fault occurs again, disconnect the appliance from the power supply for at least 30 seconds. Unplug the appliance from the mains or switch off the circuit breaker in the fuse box.</li> <li>3. If the fault persists, call customer service. → <i>Page 35</i></li> </ol> <p>Please specify the exact error message when calling. If possible, document the fault with photos and videos.</p>

Fault	Cause and troubleshooting
Heavy foam build-up.	<p>Detergent dosage is too high.</p> <ul style="list-style-type: none"> <li>▶ Mix one tablespoon of fabric softener with 0.5 litres of water and pour the mixture into compartment II (not for outdoor clothing, sportswear or items stuffed with down).</li> <li>▶ Reduce the amount of detergent for the next washing cycle with the same load.</li> </ul>
E:30	<p>The door is not completely closed.</p> <ol style="list-style-type: none"> <li>1. Ensure that there is no laundry trapped in the door.</li> <li>2. Close the door.</li> </ol>
"CL" flashes.	<p>Childproof lock is activated.</p> <ul style="list-style-type: none"> <li>▶ Deactivate the childproof lock. → <i>Page 26</i></li> </ul>
	<p>Drum cleaning is required.</p> <ul style="list-style-type: none"> <li>▶ Clean the drum. → <i>Page 27</i></li> </ul>
Drum rotates with blockages when moved by hand.	<p>Not a fault. Due to its design, the drive motor cannot be turned freely by hand. No action required.</p>
The programme does not start.	<p>Childproof lock is activated.</p> <ul style="list-style-type: none"> <li>▶ Deactivate the childproof lock. → <i>Page 26</i></li> </ul> <p> <b>Finish In</b> is activated.</p> <ul style="list-style-type: none"> <li>▶ Check whether  <b>Finish In</b> is activated. → <i>Page 19</i></li> </ul>
The programme is paused or has been interrupted, but the door will not open.	<p>The temperature is too high.</p> <ul style="list-style-type: none"> <li>▶ Start the programme or wait until the temperature has dropped.</li> </ul> <hr/> <p>Water level is too high.</p> <ul style="list-style-type: none"> <li>▶ Start the <b>Spin</b> programme or a suitable draining programme. → <i>Page 20</i></li> </ul>
The door cannot be opened due to a power cut.	<p>The door is locked.</p> <ul style="list-style-type: none"> <li>▶ Open the door using the emergency release. → <i>Page 34</i></li> </ul>
Drum jerks after the programme starts.	<p>Not a fault. An internal motor test is started. No action required.</p>
No water is visible in the drum.	<p>Not a fault. Water is below the visible area. No action required.</p>
The appliance is vibrating, 'wandering' and making loud noises during the spin cycle.	<p>Appliance is not correctly aligned.</p> <ul style="list-style-type: none"> <li>▶ Align the appliance. → <i>Page 13</i></li> </ul> <hr/> <p>The appliance feet are not fixed.</p> <ul style="list-style-type: none"> <li>▶ Secure the appliance's feet. → <i>Page 13</i></li> </ul> <hr/> <p>Transit bolts have not been removed.</p> <ul style="list-style-type: none"> <li>▶ Remove the transit bolts. → <i>Page 12</i></li> </ul>

Fault	Cause and troubleshooting
High spin speed not reached.	The appliance is using a reduced spin speed to eliminate an imbalance. No action required.
The programme duration changes during the wash cycle.	Not a fault. The programme sequence is optimised electronically or another rinse cycle is switched on due to heavy foam build-up. No action required.
Whooshing, hissing or sucking noises.	Not a fault. Water is pumped in or detergent solution is pumped out. No action required.
Banging noises, rattling in the drain pump.	A foreign object is in the drain pump. ▶ Clean the drain pump. → <i>Page 28</i>
There are detergent residues on the laundry.	Detergents may contain water-insoluble substances that deposit on the laundry. ▶ Start the programme or brush out the laundry after drying.
The laundry is too wet after the spinning cycle.	A low spin speed is selected. ▶ Start the <b>Spin</b> programme. ▶ The next time you run a wash cycle, set a higher spin speed.  The appliance is using a reduced spin speed to eliminate an imbalance. <b>1.</b> Redistribute the laundry in the drum. <b>2.</b> Start the <b>Spin</b> programme.
Creasing.	The selected programme is unsuitable for the type of fabric. ▶ Set a suitable programme. → <i>Page 20</i>  A high spin speed is selected. ▶ The next time you run a wash cycle, set a lower spin speed.  The load is unsuitable. ▶ Observe the programme's maximum load capacity. → <i>Page 20</i> ▶ Prepare the laundry. → <i>Page 23</i>
Water is leaking out at the water inlet hose.	The water inlet hose is not correctly connected or is damaged. ▶ Check the installation of the water inlet hose. → <i>Page 10</i> Replace the water inlet hose if it is damaged.

Fault	Cause and troubleshooting
Water is leaking out at the water outlet hose. E:11	The water outlet hose is not connected correctly or is damaged. ▶ Check the installation of the water outlet hose. → <i>Page 10</i> Replace the water outlet hose if it is damaged.
Water is leaking from below the door.	Dirt on the door or seal causes leaks. ▶ Clean the door and the seal.
Detergent or fabric softener drips off the seal and collects on the door or in the seal fold.	There is too much detergent or fabric softener in the detergent drawer. ▶ When dosing, observe the marking in the detergent drawer. → <i>Page 25</i>
Residual water is present in the compartment .	Insert in compartment ☼ is blocked. ▶ Clean the detergent drawer. → <i>Page 27</i>
Fabric softener remains in the detergent drawer.	The use of fabric softener is not supported for the selected programme. ▶ Check whether the use of fabric softener is supported for the selected programme. → <i>Page 20</i>
Odours have formed in the appliance.	Humidity and detergent residue may promote the formation of bacteria. ▶ Clean the drum. → <i>Page 27</i> ▶ If you are not using the appliance, leave the door and detergent drawer open so that residual water can evaporate.

## 16.1 Emergency release

### Releasing the door

**Requirement:** The drain pump is empty. → *Page 28*

- 1. ATTENTION** – Escaping water may cause material damage.
  - ▶ Do not open the door if you can see water through the glass.

Pull the emergency unlock downwards with a tool and release.

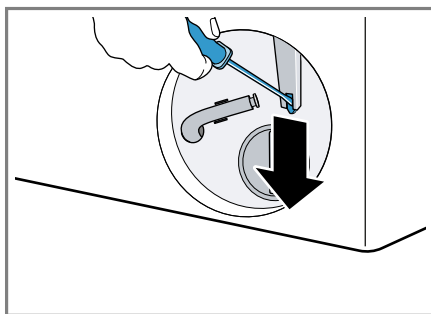

- ✓ The door lock is released.
2. Close the service flap.

---

## 17 Transportation, storage and disposal

### 17.1 Removing the appliance

1. Turn off the tap.
2. Switch off the appliance.  
→ *Page 26*
3. Unplug the appliance's mains plug.
4. Drain the water.  
→ *"Cleaning the drain pump", Page 28*
5. Detach the hoses.

### 17.2 Inserting the transit bolts

Secure the appliance before transportation using transit bolts in order to prevent transport damage.

1. Use a screwdriver to remove the 4 cover caps.  
Keep the cover caps.
2. Insert the 4 transit bolts.  
→ *"Removing the transit bolts", Page 12*

### 17.3 Using the appliance again

- ▶ For further information, see Installation and connection → *Page 10* and Starting an empty washing cycle → *Page 14*.

### 17.4 Disposing of old appliance

Valuable raw materials can be re-used by recycling.

#### **WARNING**

#### **Risk of harm to health!**

Children can lock themselves in the appliance, thereby putting their lives at risk.

- ▶ Do not install the appliance behind a door as this may obstruct the appliance door or prevent it from opening.

- ▶ With redundant appliances, unplug the power cord. Then cut through the cord and damage the lock on the appliance door beyond repair so that the appliance door will no longer close.

1. Unplug the appliance from the mains.
2. Cut through the power cord.
3. Dispose of the appliance in an environmentally friendly manner.  
Information about current disposal methods are available from your specialist dealer or local authority.

---

## 18 Customer Service

You can obtain function-relevant and storable genuine spare parts from our Customer Service for up to 15 years from the date on which your appliance was placed on the market. For more information, please contact our Customer Service team.

Detailed information about the warranty period and the warranty conditions in your country is available via the QR code on the enclosed document on service contacts and warranty conditions, from our customer service or on our website.

You can find the contact details for our customer service via the QR code on the enclosed document on service contacts and warranty conditions or on our website.

### 18.1 Product number (E-Nr.) and production number (FD)

If you contact Customer Service, you will require the product number (E-Nr.) and the production number (FD), which you can find on the appliance's rating plate.

Depending on the model, the rating plate is located:

- On the inside of the door.
- Underneath the drum opening.
- On the inside of the maintenance flap.











- On the rear of the appliance.

Make a note of your appliance's details and the Customer Service telephone number to find them again quickly.

## 19 Consumption values

The indicated consumption values are approximate.

The values may deviate from the indicated values depending on water pressure, water hardness, water inlet temperature, room temperature, type of laundry, amount and soiling of laundry, detergent used, fluctuations in the mains voltage and selected settings.

Programme	Load (kg)	Energy consumption (kWh) <sup>1</sup>	Water consumption (l) <sup>1</sup>	Programme duration (h:min) <sup>1</sup>
Cottons  20 °C	10.0	0.302	92.0	1:29
Cottons  40 °C	10.0	0.889	92.0	1:30
Cottons  60 °C <sup>2</sup>	10.0	0.496	53.0	2:18
Cottons  40 °C +  Options 	10.0	0.920	124.0	1:54
Easy Care  40 °C	4.0	0.650	69.0	1:27
Mix  40 °C	5.0	0.988	92.0	1:22
Delicates/Silk  30 °C	2.0	0.263	50.0	0:50
 Wool  30 °C	2.0	0.330	60.0	1:00

## 20 Technical data

Appliance height	85.0 cm
Appliance width	59.5 cm
Appliance depth	54.5 cm
Appliance depth with door closed	56.5 cm

Appliance depth with door open	100.4 cm
Weight	64.7 kg
Maximum load	10.0 kg
Mains voltage	220-240 V, 50 Hz
 Minimum installation protection	10 A

<sup>1</sup> Values determined according to the valid version of IEC60456

<sup>2</sup> Programme setting with maximum speed for testing in accordance with the applicable version of IEC60456 with cold water (15 °C).

Nominal power	1900-2300 W
Water pressure	<ul style="list-style-type: none"><li>■ Minimum: 100 kPa (1 bar)</li><li>■ Maximum: 1000 kPa (10 bar)</li></ul>
Length of the wa- ter inlet hose	150 cm
Length of the wa- ter outlet hose	160 cm
Length of the power cord	200 cm







# Many thanks for choosing a Bosch home appliance!

Register your new appliance now on MyBosch and benefit directly from:

- **Expert advice and tips to make the most of your appliance**
- **Options for warranty extension**
- **Discounts on spare parts and accessories**
- **Digital information for use and all appliance data to hand**
- **Easy access to Bosch Home Appliance Service**

Simple to register, free of charge – including on mobile devices:

**[www.bosch-home.com/welcome](http://www.bosch-home.com/welcome)**



## Need some help? You can find it here.

Expert advice on your Bosch home appliances, help with problems or repairs by professionals from Bosch.

Discover all the different ways Bosch can assist you:

**[www.bosch-home.com/service](http://www.bosch-home.com/service)**

The contact details of all countries are listed in the attached service directory.

### **BSH Hausgeräte GmbH**

Carl-Wery-Straße 34  
81739 München, GERMANY  
[www.bosch-home.com](http://www.bosch-home.com)

A Bosch Company



**9002028404** (051119)

en