

de Montageanleitung
 *) Über Kundendienst erhältlich

en Installation instructions
 *) Available from customer service

fr Notice de montage
 *) Disponible par le biais du service après-vente

nl Montagevoorschrift
 *) Tegen meerprijs bij de Servicedienst verkrijgbaar

it Istruzioni per il montaggio
 *) Disponibile presso il servizio assistenza clienti

es Instrucciones de montaje *) Se puede adquirir a través del Servicio de Asistencia Técnica Oficial de la marca

pt Instruções de montagem
 *) Pode ser adquirido nos nossos Serviços Técnicos

el Οδηγίες τοποθέτησης
 *) Διατίθενται από την υπηρεσία τεχνικής εξυπηρέτησης πελατών

tr Montaj kılavuzu
 *) Yetkili servis üzerinden alınabilir

sv Monteringsanvisning
 *) Kan fås via Service

no Monteringsanvisning
 *) fåes hos kundeservice

da Monteringsvejledning
 *) Kan købes hos serviceafdelingen

fi Asennusohje
 *) Saatavissa huoltopalvelusta

cs Montážní návod
 *) K dispozici přes servisní službu

sk Návod na montáž
 *) Dostanete v službe zákazníkom

pl Instrukcja montażu
 *) Do uzyskania w punkcie serwisowym

hu Szerelési utasítás
 *) A vevőszolgáltatón keresztül kapható:

ro Instrucțiune de montaj
 *) obținabilă la serviciul pentru clienți

hr Uputa za montažu
 *) može dobiti kod službe održavanja

sr Uputstvo za montažu
 *) Može se nabaviti preko servisne službe

sl Navodilo za montažo
 *) Lahko nabavite v servisni službi

mk Упатство за монтажа
 *) се добива преку службата за купувачи

et Monteerimisjuhend
 *) küsige klienditeeninduselt

lt Montavimo instrukcija
 *) Ją galima gauti klientų aptarnavimo servise

lv Montāžas pamācība
 *) Var saņemt servisa dienestā

ru Инструкция по монтажу
 *) Можно получить в сервисном центре

uk Інструкція з монтажу
 *) Можна отримати через сервісну службу

kk Іске қосу туралы нұсқаулар!
 *) Сервис қызмет көрсету орталығында алуына жатады

az Quraşdırma təlimatları
 *) Müştəri xidmətindən əldə oluna bilər

uz O'rnatish yo'riqnomasi
 *) mijozlarga xizmat ko'rsatish markazida mavjud

ka მონტაჟის ინსტრუქცია
 *) ხელმისაწვდომი კლიენტთა სამსახურში

bg Ръководство за монтаж
 *) предоставя се от службата за обслужване на клиенти

fa راهنمایی مونتاژ
 *) از مرکز خدمات پس از فروش تهیه فرمائید

ar تعليمات التركيب
 *) يمكن طلبها من مراكز خدمة العملاء

id Intruksi Pemasangan
 *) bisa didapatkan melalui Customer Service

th สามารถสั่งซื้อคู่มือการติดตั้ง
 *) ผ่านฝ่ายบริการลูกค้า

ko 설치 설명서
 *) 고객센터 센터에서 구입 가능

zh 安装说明书
 *) 可向售后服务站索取。

zh-tw 安裝說明書
 *) 可向售後服務站索取

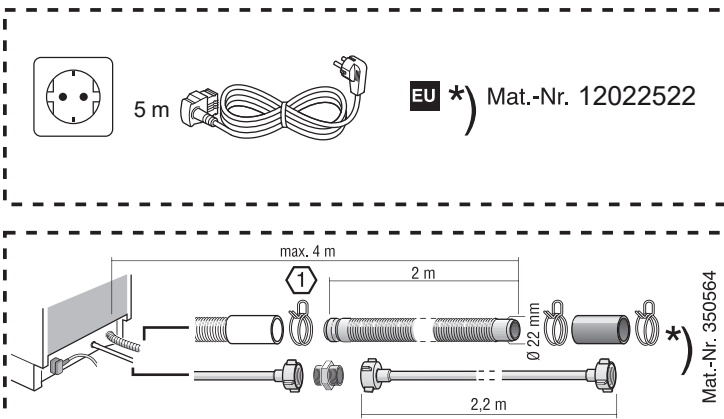
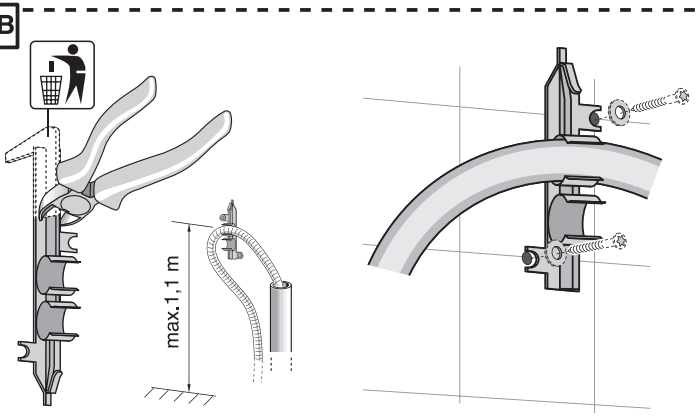
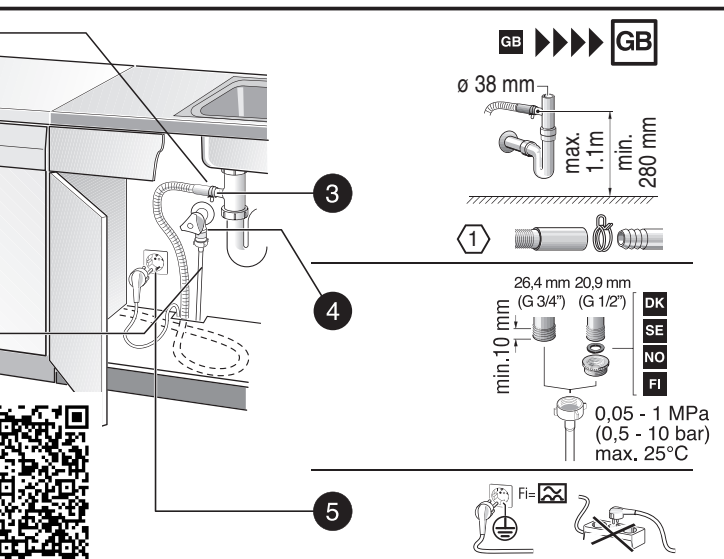
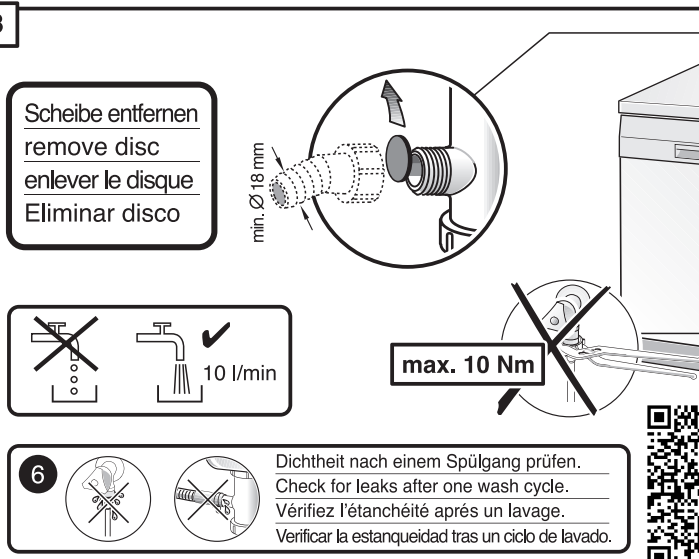
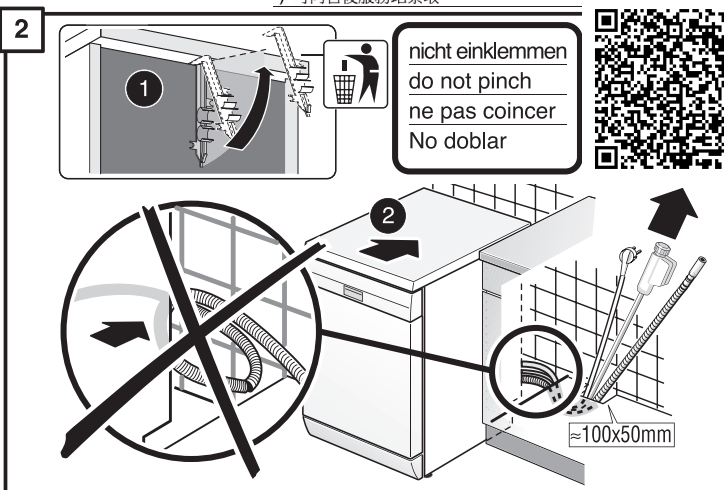
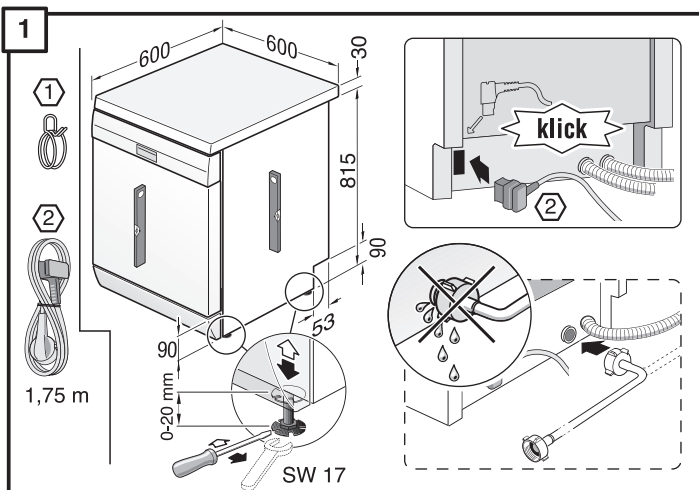

1

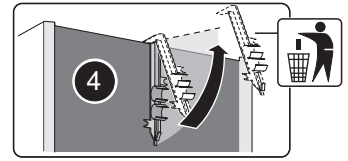
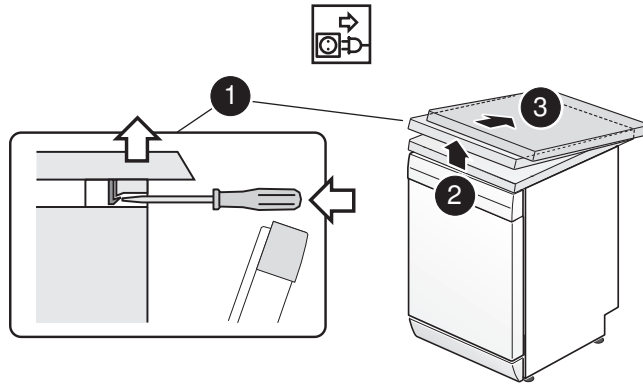
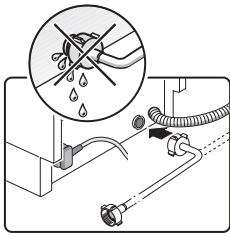
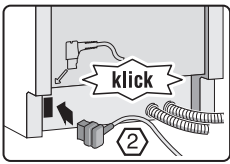

2

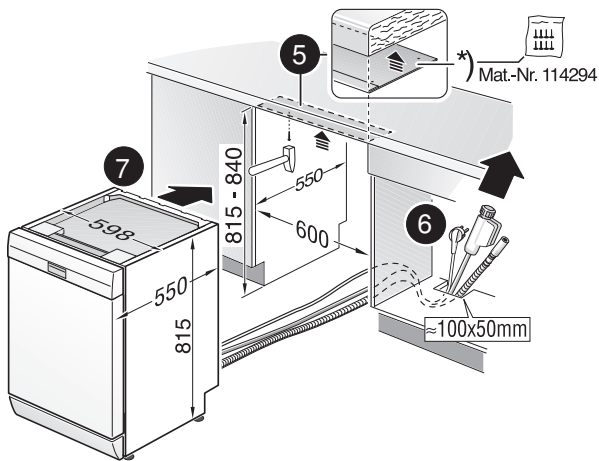

3

nicht einklemmen
do not pinch
ne pas coincer
No doblar

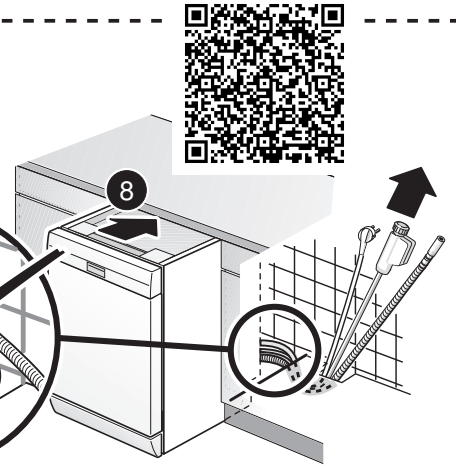

4

verspannen
brace
calar verticalment
Enrasar

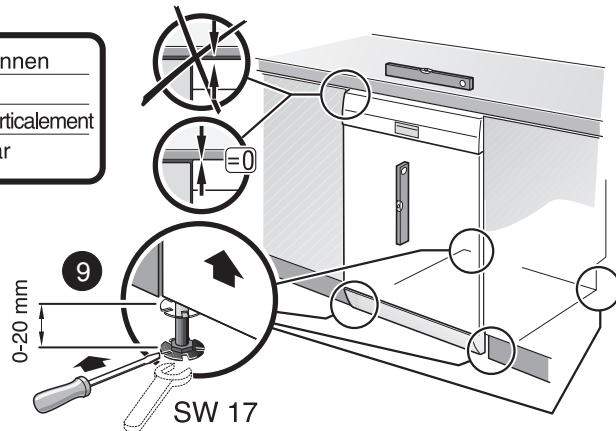

5

Scheibe entfernen
remove disc
enlever le disque
Eliminar disco

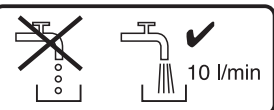
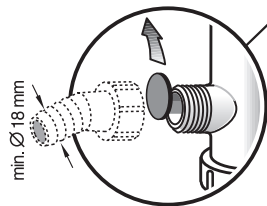

max. 10 Nm

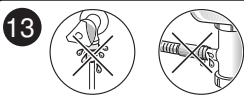

Dichtheit nach einem Spülgang prüfen.
Check for leaks after one wash cycle.
Vérifiez l'étanchéité après un lavage.
Verificar la estanqueidad tras un ciclo de lavado.



GB >>>> GB

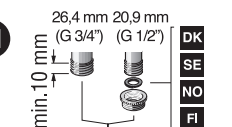
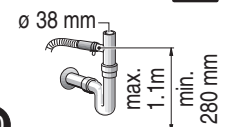

0,05 - 1 MPa
(0,5 - 10 bar)
max. 25°C

