



Register your new Bosch now:
www.bosch-home.com/welcome



**Free standing cooker
HGG223329Z**



BOSCH

[en] Instruction manual

Table of contents

Important safety information	4	Tested for you in our cooking studio	21
Causes of damage	6	Cakes and pastries	22
Damage to the oven.....	6	Baking tips	22
Damage to the plinth drawer.....	6	Meat, poultry, fish, toast.....	23
Set-up, gas and electricity connection	7	Tips for roasting and grilling.....	23
Gas connection.....	7	Acrylamide in foodstuffs	23
For your safety.....	7		
Electrical connection	8		
Levelling the cooker	8		
Setting up the appliance	8		
Measures to be noted during transport.....	8		
Your new cooker	9		
General information.....	9		
Control panel	9		
Cooking area	10		
Oven.....	10		
Your accessories	11		
Inserting the accessories	11		
Optional accessories	11		
After-sales service products	12		
Before using the oven for the first time	12		
Heating up the oven.....	12		
Setting procedure for the lower gas burner	12		
Procedure for setting the gas grill	13		
Cleaning the accessories.....	13		
Advance cleaning of burner cup and cap	13		
Suitable pans	14		
Precautions for use	14		
Making settings on the hob	14		
Igniting the gas burners.....	14		
Table - Cooking.....	15		
Setting the oven	15		
This is how you adjust the lower gas burner in the oven	15		
Procedure for setting the gas grill	15		
Grilling with the rotary spit	16		
Preparing roasts.....	16		
Inserting the rotary spit.....	16		
Procedure for setting the rotary spit and grill.....	16		
Care and cleaning	17		
Upper glass cover	17		
Cleaning agents	17		
Detaching and refitting the rails.....	18		
Detaching and attaching the oven door.....	19		
Removing and installing the door panels	19		
Troubleshooting	20		
Fault table.....	20		
Replacing the bulb in the oven ceiling light	20		
Glass cover	20		
After-sales service	21		
E number and FD number	21		
Energy and environment tips	21		
Saving energy.....	21		
Saving energy with the gas hob	21		
Environmentally-friendly disposal.....	21		

Additional information on products, accessories, replacement parts and services can be found at www.bosch-home.com and in the online shop www.bosch-eshop.com

Important safety information

Read these instructions carefully. Only then will you be able to operate your appliance safely and correctly. Retain the instruction manual and installation instructions for future use or for subsequent owners.

These instructions are only valid if the appropriate country symbol appears on the appliance. If the symbol does not appear on the appliance, it is necessary to refer to the technical instructions which will provide the necessary instructions concerning modification of the appliance to the conditions of use of the country.

Appliance category: Category 1

Check the appliance for damage after unpacking it. Do not connect the appliance if it has been damaged in transport.

Only allow a licensed professional to connect the appliance and to convert the appliance to a different type of gas. The appliance must be installed (electric and gas connections) in accordance with the instruction and installation manual. An incorrect connection or incorrect settings may lead to serious accidents and damage to the appliance. The appliance manufacturer accepts no liability for damage of this kind. The appliance's warranty becomes void.

Caution: This appliance is for cooking purposes only. It must not be used for other purposes, for example room heating.

Caution: The use of a gas cooking appliance results in the production of heat, moisture and products of combustion in the room in which it is installed. Ensure that the kitchen is well ventilated especially when the appliance is in use: keep natural ventilation holes open or install a mechanical ventilation device (mechanical extractor hood).

Prolonged intensive use of the appliance may call for additional ventilation, for example opening of a window, or more effective ventilation, for example increasing the level of mechanical ventilation where present.

This appliance is not intended for operation with an external timer or a remote control.

Do not use inappropriate child safety shields or hob guards. These can cause accidents.

This appliance may be used by children over the age of 8 years old and by persons with reduced physical, sensory or mental capabilities or by persons with a lack of experience or knowledge if they are supervised or are instructed by a person responsible for their safety how to use the appliance safely and have understood the associated hazards.

Children must not play with, on, or around the appliance. Children must not clean the appliance or carry out general maintenance unless they are at least 8 years old and are being supervised.

Keep children below the age of 8 years old at a safe distance from the appliance and power cable.

Always slide accessories into the cooking compartment correctly. See "*Description of accessories*" in the instruction manual.

Risk of fire!

- A draught is created when the appliance door is opened. Greaseproof paper may come into contact with the heating element and catch fire. Do not place greaseproof paper loosely over accessories during preheating. Always weight down the greaseproof paper with a dish or a baking tin. Only cover the surface required with greaseproof paper. Greaseproof paper must not protrude over the accessories.
- Combustible objects that are left in the cooking compartment may ignite. Never store combustible items in the cooking compartment. Never open the appliance door if there is smoke inside. Switch off the appliance and unplug the mains plug or switch off the fuse in the fuse box. Shut off the gas supply.
- Hot oil and fat can ignite very quickly. Never leave hot fat or oil unattended. Never use water to put out burning oil or fat. Switch off the hotplate. Extinguish flames carefully using a lid, fire blanket or something similar.
- The hotplates become very hot. Never place combustible items on the hob. Never place objects on the hob.

- The appliance becomes very hot, and flammable materials can easily catch fire. Do not store or use any flammable objects (e.g. aerosol cans, cleaning agents) under or in the vicinity of the oven. Do not store any flammable objects inside or on top of the oven.
- When gas hotplates are in operation without any cookware placed on them, they can build up a lot of heat. The appliance and the extractor hood above it may become damaged or be set on fire. Grease residue in the filter of the extractor hood may ignite. Only operate the gas burners with cookware on them.
- The rear of the appliance becomes very hot. This may cause damage to the power cables. Electricity and gas lines must not come into contact with the rear of the appliance.
- Never place flammable objects on the burners or store them in the cooking compartment. Never open the appliance door if there is smoke inside. Switch off the appliance. Pull out the mains plug or switch off the appliance at the circuit breaker in the fuse box. Shut off the gas supply.
- The surfaces of the plinth drawer may become very hot. Only store oven accessories in the drawer. Flammable and combustible objects must not be stored in the plinth drawer.

Risk of burns!

- The appliance becomes very hot. Never touch the interior surfaces of the cooking compartment or the heating elements. Always allow the appliance to cool down. Keep children at a safe distance.
- Accessories and ovenware become very hot. Always use oven gloves to remove accessories or ovenware from the cooking compartment.
- Alcoholic vapours may catch fire in the hot cooking compartment. Never prepare food containing large quantities of drinks with a high alcohol content. Only use small quantities of drinks with a high alcohol content. Open the appliance door with care.
- The hotplates and surrounding area (particularly the hob surround, if fitted) become very hot. Never touch the hot surfaces. Keep children at a safe distance.

- During operation, the surfaces of the appliance become hot. Do not touch the surfaces when they are hot. Keep children away from the appliance.
- Empty cookware becomes extremely hot when set on a gas hotplate that is in operation. Never heat up empty cookware.
- The appliance becomes hot during operation. Allow the appliance to cool down before cleaning.
- **Caution:** Accessible parts may be hot when the grill is in use. Young children should be kept away from the appliance.
- If the liquefied gas bottle is not upright, liquefied propane/butane can enter the appliance. Intense darting flames may therefore escape from the burners. Components may become damaged and start to leak over time so that gas escapes uncontrollably. Both can cause burns. Always use liquefied gas bottles in an upright position.

Risk of scalding!

- The accessible parts become hot during operation. Never touch the hot parts. Keep children at a safe distance.
- When you open the appliance door, hot steam may escape. Open the appliance door with care. Keep children at a safe distance.
- Water in a hot cooking compartment may create hot steam. Never pour water into the hot cooking compartment.

Risk of injury!

- Scratched glass in the appliance door may develop into a crack. Do not use a glass scraper, sharp or abrasive cleaning aids or detergents.
- Incorrect repairs are dangerous. Repairs may only be carried out, and damaged power and gas lines replaced, by an after-sales engineer trained by us. If the appliance is faulty, unplug the mains plug or switch off the fuse in the fuse box. Shut off the gas supply. Contact the after-sales service.
- Faults or damage to the appliance are dangerous. Never switch on a faulty appliance. Unplug the appliance from the mains or switch off the circuit breaker in the fuse box. Shut off the gas supply. Contact the after-sales service.

- Unsuitable pan sizes, damaged or incorrectly positioned pans can cause serious injury. Observe the instructions which accompany the cookware.
- **Caution:** Glass lids may shatter when heated. Turn off all the burners before shutting the lid. Wait until the oven has cooled down before closing the glass cover.



Risk of electric shock!

- Incorrect repairs are dangerous. Repairs may only be carried out by one of our trained after-sales engineers. If the appliance is faulty, unplug the mains plug or switch off the fuse in the fuse box. Contact the after-sales service.
- The cable insulation on electrical appliances may melt when touching hot parts of the appliance. Never bring electrical appliance cables into contact with hot parts of the appliance.
- Do not use any high-pressure cleaners or steam cleaners, which can result in an electric shock.
- When replacing the cooking compartment bulb, the bulb socket contacts are live. Before replacing the bulb, unplug the appliance from the mains or switch off the circuit breaker in the fuse box.
- A defective appliance may cause electric shock. Never switch on a defective appliance. Unplug the appliance from the mains or switch off the circuit breaker in the fuse box. Contact the after-sales service.

Causes of damage

Hob

Caution!

- Only use the burners when cookware has been placed on top. Do not heat up empty pots or pans. The saucepan base will be damaged.
- Only use pots and pans with an even base.
- Place the pot or pan centrally over the burner. This will optimise transfer of the heat from the burner flame to the pot or pan base. The handle does not become damaged, and greater energy savings are guaranteed.
- Ensure that the gas burners are clean and dry. The burner cup and burner cap must be positioned exactly.
- Ensure that the top cover is not closed when the oven is started up.

Damage to the oven

Caution!

- Accessories, foil, greaseproof paper or ovenware on the cooking compartment floor: do not place accessories on the cooking compartment floor. Do not cover the cooking compartment floor with any sort of foil or greaseproof paper. Do not place ovenware on the cooking compartment floor if a temperature of over 50 °C has been set. This will cause heat to accumulate. The baking and roasting times will no longer be correct and the enamel will be damaged.
- Water in a hot cooking compartment: do not pour water into the cooking compartment when it is hot. This will cause steam. The temperature change can cause damage to the enamel.

- Moist food: do not store moist food in the cooking compartment when it is closed for prolonged periods. This will damage the enamel.
- Fruit juice: when baking particularly juicy fruit pies, do not pack the baking tray too generously. Fruit juice dripping from the baking tray leaves stains that cannot be removed. If possible, use the deeper universal pan.
- Cooling with the appliance door open: only allow the cooking compartment to cool when it is closed. Even if the appliance door is only open a little, front panels of adjacent units could be damaged over time.
- Very dirty door seal: If the door seal is very dirty, the appliance door will no longer close properly when the appliance is in use. The fronts of adjacent units could be damaged. Always keep the door seal clean.
- Appliance door as a seat, shelf or worktop: Do not sit on the appliance door, or place or hang anything on it. Do not place any cookware or accessories on the appliance door.
- Inserting accessories: depending on the appliance model, accessories can scratch the door panel when closing the appliance door. Always insert the accessories into the cooking compartment as far as they will go.
- Carrying the appliance: do not carry or hold the appliance by the door handle. The door handle cannot support the weight of the appliance and could break.

Damage to the plinth drawer

Caution!

Do not place hot objects in the plinth drawer. It could be damaged.

Set-up, gas and electricity connection

Gas connection

Installation must only be performed by an approved expert or a licensed after-sales service engineer in accordance with the instructions specified under "Gas connection and conversion to a different gas type".

For the licensed expert or after-sales service

Caution!

- The setting conditions for this appliance are specified on the rating plate on the back of the appliance. The gas type set in the factory is marked with an asterisk (*).
- Before setting up the appliance, check the grid access conditions (gas type and gas pressure) and ensure that the gas setting of the appliance meets these conditions. If the appliance settings have to be changed, follow the instructions in the section "Gas connection and conversion to a different gas type".
- This appliance is not connected to a waste gas main. It must be connected and commissioned in accordance with the installation conditions. Do not connect the appliance to a waste gas main. All ventilation regulations must be observed.
- The gas connection must be made via a fixed, i.e. not mobile connection (gas line) or via a safety hose.
- If using the safety hose, ensure that the hose is not trapped or crushed. The hose must not come into contact with hot surfaces.
- The gas line (gas pipe or safety hose) can be connected to the right or left-hand side of the appliance. The connection must have an easily accessible locking device.

Safety information

The rated working pressure of your appliance is:

for natural gas (G20) 2 kPa;

for LPG (G30) 3 kPa;

for LPG (G31) 3,7 kPa.

Your appliance must be operated with these pressures. All the information on the rating plate of your appliance is based on these pressures. The manufacturer takes no responsibility for the resulting operability or performance of the appliance or for other risks if the appliance is operated with pressures other than those specified.

Caution!

If the pressure of your local gas supply is higher than:

natural gas (G20) 2,5 kPa;

LPG (G30) 3,6 kPa;

or LPG (G31) 4,5 kPa; for safety reasons, the appliance must be equipped with a suitable pressure regulator. The connection, maintenance and setting of the pressure regulator must be carried out by an approved gas fitter.

If you do not know the pressure of your local gas supply, ask your gas supplier.

For your safety

This appliance is adjusted to operate on LPG only.

Faults in the gas installation/smell of gas

If you notice a smell of gas or faults in the gas installation, you must

- immediately shut off the gas supply and/or close the gas cylinder valve
- immediately extinguish all naked flames and cigarettes
- switch off electrical appliances and lights
- open windows and ventilate the room
- call the after-sales service or the gas supplier

Burn back

Fire in burner tube or chamber

In the event of a burn-back, where the flame burns back to the jet, immediately turn off the gas supply at the control valve on the panel.

After ensuring the flame is extinguished, re-light the appliance in the normal manner.

Should the appliance again burn back, close the control valve and call a service technician. Do not use the appliance again until the service technician has declared that it is safe to do so.

Gas-pressure regulator

This appliance requires an operating pressure of 2,8 kPa at the appliance. A suitable LPG regulator that complies with the requirements of SANS 1237 must be installed.

Important information for the user

This appliance may only be installed by a registered LP Gas installer.

All registered installers are issued with a card carrying their registration number. Ask to be shown the card before allowing the installation work to be shown the card before allowing the installation work to commence and make a note of the installer QCC number.

Upon completion of the installation, the installer is required to explain the operational details of the appliance together with the safety instructions.

You should only sign for acceptance of the installation and be provided with a completion certificate. You should only sign for acceptance of the installation when the installation is completed to your satisfaction.

Note that your invoice is required in the event that you wish make a warranty claim.

Important information for the installer

This appliance may only be installed by a registered LP Gas installer registered with the Liquefied Petroleum Gas Association of Southern Africa.

The appliance must be installed in accordance with the requirements of SANS 10087-1 and any fire department regulations and/or local bylaws applicable to the area. If in doubt check with the relevant authority before undertaking the installation.

Upon completion of the installation you are required to fully explain and demonstrate to the user the operational details and safety practices applicable to the appliance and the installation.

Moving the appliance by the gas line or door handle

Do not move the appliance while holding the gas line; the gas pipe could be damaged. There is a risk of a gas leak! Do not move the appliance while holding it by the door handle. The door hinges and door handle could be damaged.

Electrical connection

Caution!

- Have the appliance set up by your after-sales service. A 16 A fuse is required for connection. The appliance is designed for operation at 220-240 V.
- If the electricity supply drops below 180 V, the electrical ignition system does not work.
- Any damage arising from the appliance being connected incorrectly will invalidate the guarantee.
- If the supply cord is damaged, it must be replaced by the manufacturer, its service agent or similarly qualified persons in order to avoid a hazard.

For the after-sales service

Caution!

- The appliance must be connected in accordance with the data on the rating plate.
- Only connect the appliance to an electrical connection that meets the applicable provisions. The socket must be easily accessible so that you can disconnect the appliance from the electricity supply if necessary.
- Please ensure the availability of a multi-pin disconnecting system.
- Never use extension cables or multiple plugs.
- For safety reasons, this appliance must only be connected to an earthed connection. If the safety earth terminal does not comply with regulations, safety against electrical hazards is not guaranteed.
- You must use a H 05 W-F type cable or equivalent for the appliance connection.

Levelling the cooker

Always place the cooker directly on the floor.

1. Pull out the plinth drawer and lift it up and out. There are adjustable feet at the front and rear on the inside of the plinth.
2. Use an Allen key to raise or lower the adjustable feet as necessary until the cooker is level (picture A).
3. Push the plinth drawer back in (picture B).

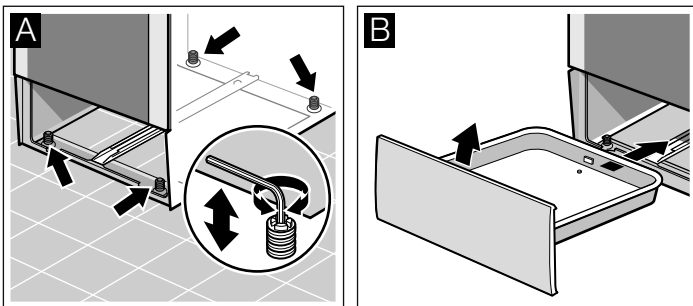

Setting up the appliance

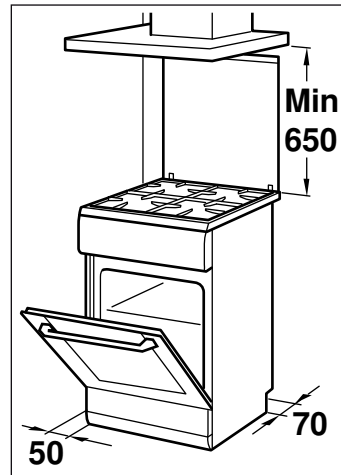

- The appliance must be set up directly on the kitchen floor and in line with the specified dimensions. The appliance must not be set up on any other object.
- The distance between the top edge of the oven and the bottom edge of the extractor hood must meet the requirements of the extractor hood manufacturer.
- Ensure that the appliance is not moved again after set up. The distance from the high output burner or wok burner to the fronts of the adjacent units or the wall must be at least 50 mm.

Measures to be noted during transport

Secure all mobile parts in and on the appliance using an adhesive tape that can be removed without leaving any traces. Push all accessories (e.g. baking tray) into the corresponding slots with cardboard at the edges, in order to avoid damaging the appliance. Place cardboard or similar between the front and rear side to prevent knocks against the inside of the glass door. Secure the door and, if available, the top cover to the appliance sides using adhesive tape.

Keep the original appliance packaging. Only transport the appliance in the original packaging. Observe the transport arrows on the packaging.

If the original packaging is no longer available

pack the appliance in protective packaging to guarantee sufficient protection against any transport damage.

Transport the appliance in an upright position. Do not hold the appliance by the door handle or the connections on the rear, as these could be damaged. Do not place any heavy objects on the appliance.

Your new cooker

Here you will learn about your new cooker. We will explain the control panel, the hob and the individual operating controls.

You will find information on the cooking compartment and the accessories.

General information

The design depends on the respective appliance model.

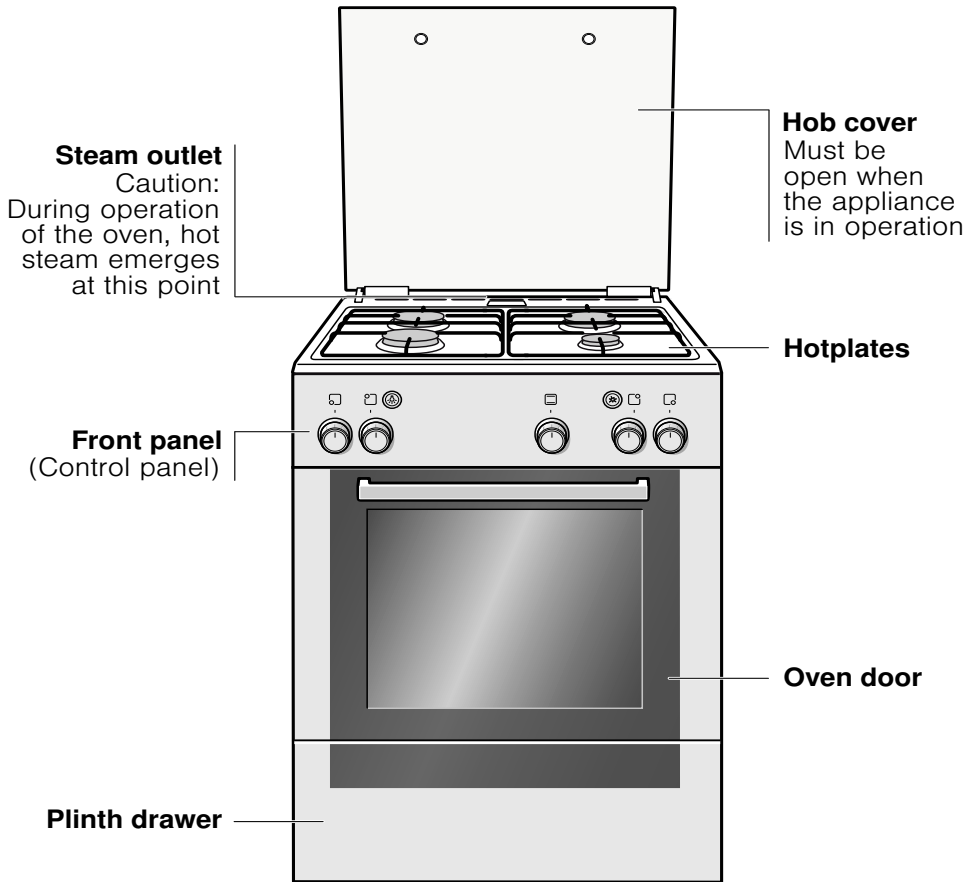

Control panel

Here you can see an overview of the control panel. The design depends on the respective appliance model.

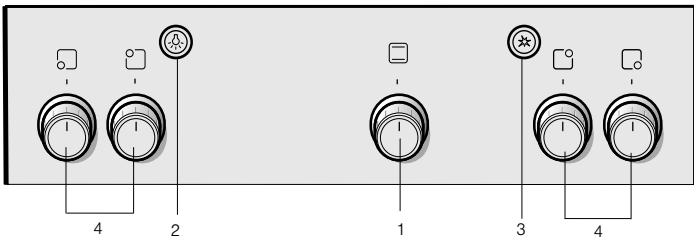

Explanations

1	Switch for the gas burner (function selector)
2	Multi-function button
3	Ignition button
4	Cooker switch

Cooking area

Here is an overview of the control panel. The design depends on the respective appliance model.

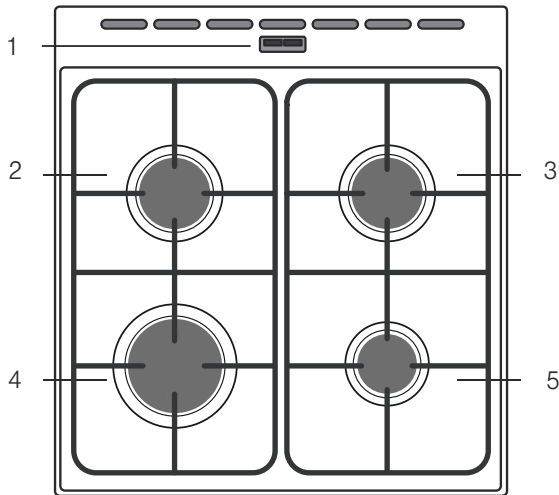

Explanations

1 Steam outlet

Caution!

During oven operation, hot steam escapes at this point

2 Standard burner

3 Standard burner

4 High output burner

5 Economy burner

Burner knob

You can adjust the heat setting of the hotplates using the four burner knobs.

The Positions	Function/gas oven
⏻ Zero position	The oven is switched off.
🔥 Settings area	Large flame = highest setting Economy flame = lowest setting

There is a limit stop at the end of the settings area. Do not turn the timer beyond this.

Ignition button

This button activates the electronic ignition system.

When you press the button, all igniters ignite at the same time.

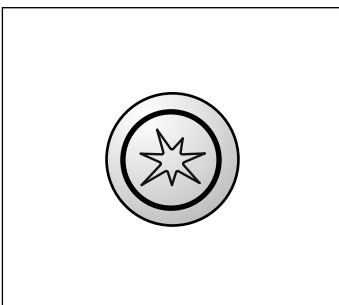

Oven

Function selector

Turn the function selector anti-clockwise to set the oven temperature or clockwise to select the grill.

Positions		Function
⏻	Zero position	Oven not hot.
170-270	Temperature range	Temperature range in °C for baking cakes in baking tins, pizza on the baking sheet, biscuits etc.
🔥	Grill setting	Grill burner setting for grilling at maximum temperature.

Heat setting for the lower burner: 3 kW

Heat setting of the gas grill: 2,1 kW

Multi-function button

You can use this button to set 2 different functions.

When you press the button, the rotary spit is switched on and the oven light comes on.

To switch it off, press the multi-function button again.

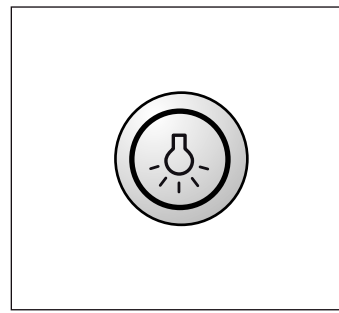

Your accessories

The accessories supplied with your appliance are suitable for making many meals. Ensure that you always insert the accessories into the cooking compartment the right way round.

There is also a selection of optional accessories, with which you can improve on some of your favourite dishes, or simply to make working with your oven more convenient.

Inserting the accessories

The accessories can be inserted in the oven at 5 different levels. Always slide the accessories fully in to avoid them coming into contact with the oven's glass door.

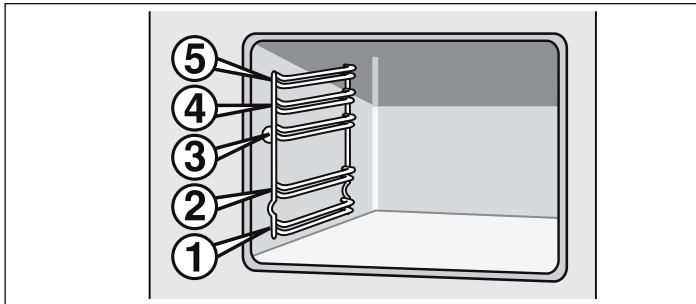

The accessories can be pulled out approximately halfway without tipping. This allows meals to be taken out easily.

When placing the accessories into the oven, check that the indentation is at the back. They can only lock correctly in place in this position.

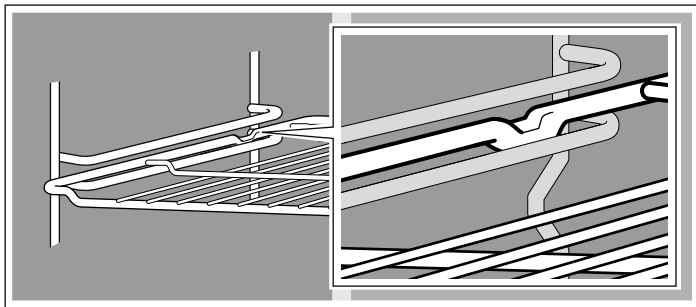

Optional accessories

You can buy optional accessories from your after-sales service or from specialist retailers. You will find a variety of suitable products for your oven in our brochures and on the Internet. The availability of optional accessories and the options for

Note: Heat may cause the accessories to deform. As soon as the accessories cool down, they regain their original shape. Their function is not adversely affected.

Hold the baking tray securely on the sides with both hands and push it parallel into the frame. Avoid movements to the right or left when pushing the baking tray in. Otherwise, it will be difficult to push the tray in and the enamelled surfaces could be damaged.

You can buy accessories from the after-sales service, from specialist retailers or online. Please specify the HEZ number.



Wire rack

For cookware, cake tins, roasts, grilling and frozen meals.

Insert the wire rack with the open side facing the oven door and the curvature pointing downwards .

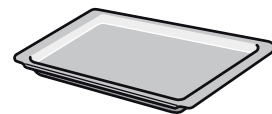

Aluminium baking tray

For cakes and biscuits.

Push the baking tray into the oven with the sloping edge facing towards the oven door.



Enamel baking tray

For cakes and biscuits.

Push the baking tray into the oven with the sloping edge facing towards the oven door.

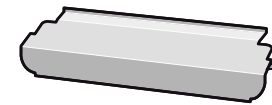

Protecting plate

For use during grilling.

You must use the protecting plate when grilling to protect the control panel and control knob from high temperatures.

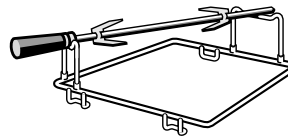

Rotary spit

For roasting joints and large poultry.

You can use the rotary spit with the enamel baking tray or with the universal pan.

Note: The protecting plate is kept in the plinth drawer.

ordering them on the internet vary depending on the country. You can find information about this in the sales brochures.

Not every optional accessory is suitable for every appliance. When making a purchase, always quote the full name (E no.) of your appliance.

Optional accessories	HEZ number	Function
Pizza tray	HEZ317000	Particularly good for pizza, frozen meals and round tarts. You can use the pizza tray instead of the universal pan. Slide the tray in above the wire rack and proceed according to the instructions in the tables.
Wire insert	HEZ324000	For roasting. Always place the grill wire rack on the universal pan. This ensures that dripping fat and meat juices are collected.
Grill tray	HEZ325000	Used for grilling instead of the grill wire rack or used as a splatter guard to protect the oven from becoming heavily soiled. Only use the grill tray with the universal pan. Grilling on the grill tray: only shelf positions 1, 2 and 3 can be used. The grill tray as a splash guard: the universal pan is inserted together with the grill tray under the wire rack.

Optional accessories	HEZ number	Function
Baking stone	HEZ327000	The baking stone is perfect for preparing home-made bread, bread rolls and pizzas which require a crispy base. The baking stone must always be preheated to the recommended temperature.
Enamel baking tray	HEZ331003	For cakes and biscuits. Slide the baking tray into the oven with the sloping edge facing towards the oven door.
Enamel baking tray with non-stick coating	HEZ331011	The baking tray is ideal for laying out cakes and biscuits. Slide the baking tray into the oven with the sloping edge facing towards the oven door.
Universal pan	HEZ332003	For moist cakes, pastries, frozen meals and large roasts. Can also be used under the wire rack to catch fat or meat juices. Slide the universal pan into the oven with the sloping edge facing towards the oven door.
Universal pan with non-stick coating	HEZ332011	This universal pan is ideal for moist cakes, pastries, frozen meals and large roasts. Slide the universal pan into the oven with the sloping edge facing towards the oven door.
Lid for the Profi extra-deep pan	HEZ333001	The lid converts the Profi extra-deep pan into the Profi roasting dish.
Profi extra-deep pan with insert wire rack	HEZ333003	Particularly suitable for preparing large quantities of food.
Wire rack	HEZ334000	For ovenware, cake tins, roasts, grilling and frozen meals.
Telescopic shelf rail		
2-level shelf rail	HEZ338250	With the pull-out rails at level 2 and 3, the accessories can be fully pulled out without tipping.
Glass roasting dish	HEZ915001	The glass roasting dish is suitable for pot roasts and bakes. Ideal for programmes and automatic roasting.

After-sales service products

You can obtain suitable care and cleaning agents and other accessories for your domestic appliances from the after-sales

service, specialist retailers or (in some countries) online via the e-Shop. Please specify the relevant product number.

Cleaning cloths for stainless-steel surfaces	Product no. 311134	Reduces the build-up of dirt. Impregnated with a special oil for perfect maintenance of your appliance's stainless-steel surfaces.
Oven and grill cleaning gel	Product no. 463582	For cleaning the cooking compartment. The gel is odourless.
Microfibre cloth with honeycomb structure	Product no. 460770	Especially suitable for cleaning delicate surfaces, such as glass, glass ceramic, stainless steel or aluminium. The microfibre cloth removes liquid and grease deposits in one go.
Door lock	Product no. 612594	To prevent children from opening the oven door. The locks on different types of appliance door are screwed in differently. See the information sheet supplied with the door lock.

Before using the oven for the first time

In this section, you can find out what you must do before using your oven or gas hob to prepare food for the first time. First read the section on *Safety information*.

Heating up the oven

To remove the new cooker smell, heat up the oven when it is empty and closed. Ensure that no packaging material has been left in the cooking compartment.

Setting procedure for the lower gas burner

Example in the picture: Heat at 270 °C

1. Open the top cover. The top cover must remain open for as long as the oven is in operation.
2. Open the main gas supply to the appliance. Connect the plug in the socket. Open the oven door.
3. Push in the switch for the lower gas burner and turn it to 270 °C.
4. While holding the switch for the oven's lower gas burner depressed, press the ignition button .

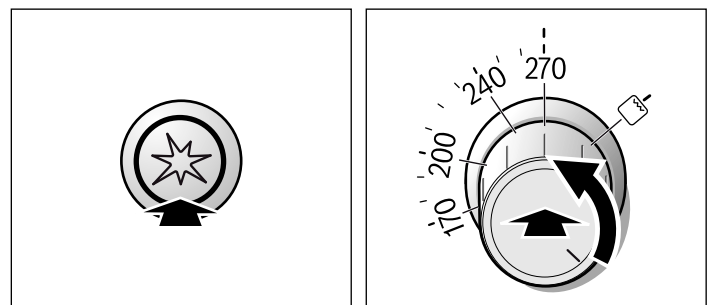

5. The gas escaping from the oven's lower gas burner is ignited using the ignition button. To activate the safety pilot, press and hold the lower gas burner on the oven for 10 seconds.
6. Look through the inspection port to make sure that the flame is lit. If it is not, repeat the process from step 3.
7. Close the oven door slowly.
8. Turn off the switch for the lower gas burner after 30 minutes.

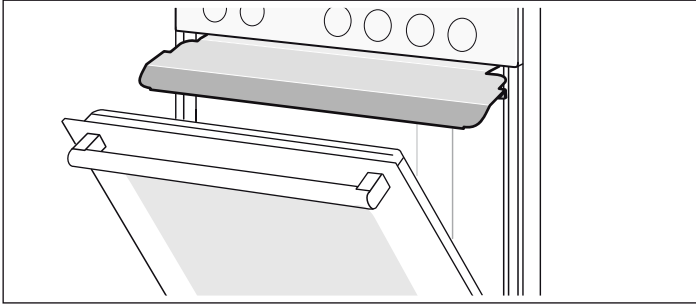

Procedure for setting the gas grill

1. Open the top cover. The top cover must remain open for as long as the oven is in operation.
2. Turn on the main gas supply to the appliance. Connect the plug to the socket.
3. Insert the protecting plate into the groove under the control panel.
The protecting plate is inserted with the longer edge facing forwards and the curvature facing downwards.



Fasten the protecting plate in the groove under the control panel using the retainers.

Make sure that the protecting plate is latched into the retainers. Once the protecting plate cannot be removed, it is correctly latched in place. You can now safely use the protecting plate. If it can be removed, insert it into the groove at a slightly higher angle and make sure that it latches into the retainers.

4. Close the oven door so that it is in contact with the protecting plate.
5. Press the function selector and turn it clockwise to the grill setting .
6. Keep the function selector pressed in and simultaneously press the ignition button .

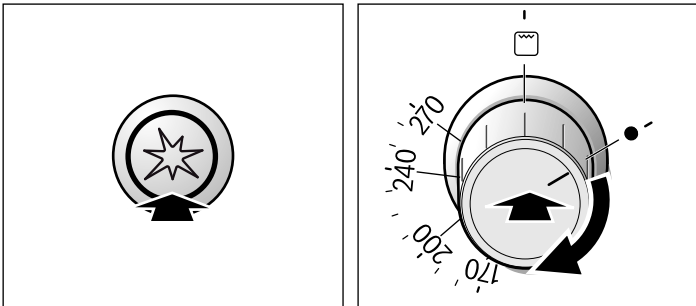

7. The gas leaving the gas grill is ignited using the ignition button. To ensure that the ignition safety system responds, press and hold the function selector for 10 seconds.
8. Check whether the flame is lit. If the flame is not lit, repeat the process from step 5.
9. Switch off the function selector after 30 minutes. Once the oven has cooled down, remove the protecting plate.

Caution!

The gas grill only works when the protecting plate is inserted. Make sure that the protecting plate is correctly inserted.

Cleaning the accessories

Before you use the accessories for the first time, clean them thoroughly with hot soapy water and a soft dish cloth.

Advance cleaning of burner cup and cap

Clean the burner cap (1) and cup (2) with water and washing-up liquid. Dry the individual parts carefully.

Place the burner cup and cap back on the burner shell (5). Ensure that the igniter (3) and flame safety pin (4) are not damaged.

The nozzle (6) must be dry and clean. Always position the burner cap exactly over the burner cup.

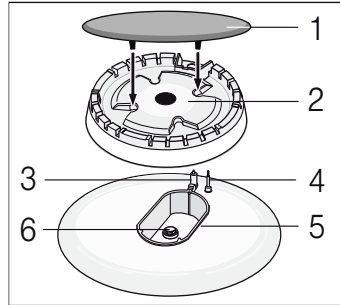

Suitable pans

Burner/electric hot-plate	Minimum pan diameter	Maximum pan diameter
Electric hotplate*	14.5 cm	14.5 cm
Wok burner** 3.6 kW	24 cm	28 cm
High output burner 3kW	24 cm	28 cm
Standard burner 1.7 kW	18 cm	24 cm
Economy burner 1 kW	12 cm	18 cm

* Option (for models with an electric hotplate)

** Option (for models with a wok burner)

Precautions for use

The following advice is intended to help you save energy and prevent pan damage:

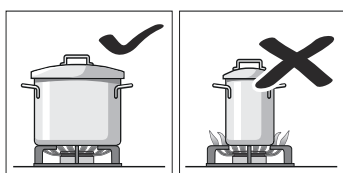

Use pans which are the right size for each burner.
Do not use small pans on large burners. The flame must not touch the sides of the pan.

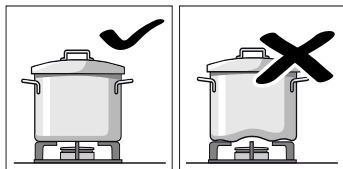

Do not use damaged pans, which do not sit evenly on the hob. Pans may tip over.
Only use pans with a thick, flat base.

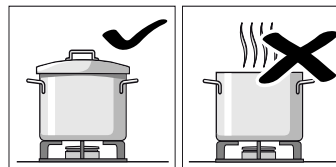

Do not cook without using a lid and make sure the lid is properly fitted. This wastes energy.

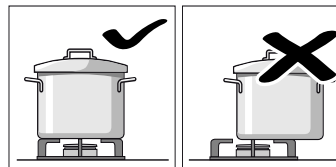

Always place the ovenware centrally over the burner. Otherwise, there is a risk that it may tip over.

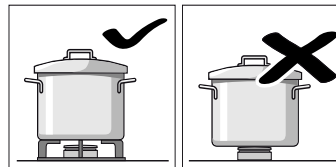

Place the pans on the pan supports, never directly on the burner.

Make sure that the pan supports and burner caps are correctly positioned before using the appliance.

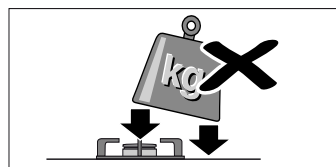

Pans should be placed on the hob carefully.

Do not strike the hob and do not place excessive weight on it.

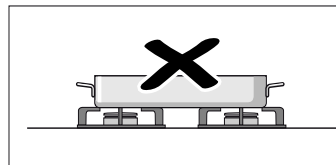

Never use two burners or heat sources to heat one single pan.

Do not use grill pans, earthenware casserole dishes, etc. for a long period of time on maximum power.

Making settings on the hob





Your hob is equipped with four gas burners. The following information explains how to light the gas burners and set the size of flame.

Igniting the gas burners

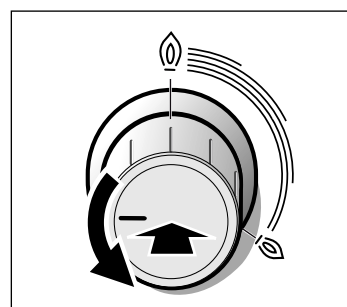
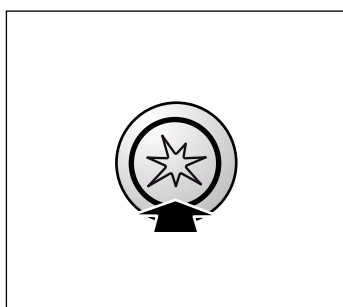
Always position the burner cap exactly over the burner cup. Openings on the burner cup are always unobstructed. All parts must be dry.

1. Open the top cover. The top cover must remain open for as long as the oven is in operation.
2. Turn the switch for the desired burner anticlockwise to the large flame symbol .
3. Press and hold the burner knob and press the ignition button at the same time. The gas burner ignites.



4. Press and hold the burner knob for approximately 1-3 seconds. The safety pilot is activated. If the gas flame goes out, the gas supply is automatically interrupted by the safety pilot.
5. Set the desired flame size. Between setting  Off and setting , the flame is not stable. Therefore, always choose a setting between  large and  small flame.
6. If the flame goes out again, repeat the process from step 2.
7. To end the cooking process: Turn the burner knob  clockwise to the Off position.

The ignition device should not be actuated for more than 15 seconds. If the burner does not light within 15 seconds, wait for at least one minute. Then repeat the ignition process.

The gas burner does not ignite

If there is a power cut or if the ignition plugs are damp, you can light the gas burners with a gas lighter or a match.

Table - Cooking

Select the right saucepan size for each burner. The diameter of the pot or pan base should be the same as that of the burner.

Cooking times depend on the type, weight and quality of the food. Deviations are therefore possible. You yourself can best judge the optimal cooking time.

Minerals and vitamins are very quickly destroyed during cooking. Therefore, only use a little water. This will help you retain vitamins and minerals. Select short cooking times so that the vegetables remain firm and full of nutrients.

Example	Dish	Burner	Heat setting
Melting	Chocolate, butter, margarine	Economy burner	small flame
Heating	Stock, tinned vegetables	Standard burner	small flame
Heating and keeping warm	Soups	Economy burner	small flame
Braising*	Fish	Standard burner	between large and small flame
Braising*	Potatoes and miscellaneous vegetables, meat	Standard burner	between large and small flame
Cooking*	Rice, vegetables, meat dishes (with sauces)	Standard burner	Large flame
Roasting	Pancakes, potatoes, schnitzel, fish fingers	High output burner	between large and small flame

* If you are using a saucepan with a cover, turn the flame down as soon as it reaches boiling point.

Setting the oven

Here you can find out how to set the oven.

This is how you adjust the lower gas burner in the oven

When the lower gas burner is lit, you can bake on a baking sheet with the oven door closed.

Example in the picture: Baking at 170 °C

1. Open the top cover. The top cover must remain open for as long as the oven is in operation.
2. Open the main gas supply to the appliance. Connect the plug to the socket. Open the oven door.
3. Push in the switch for the lower gas burner and turn it to 170 °C.
4. While holding the switch for the lower gas burner depressed, press the ignition button ✨.

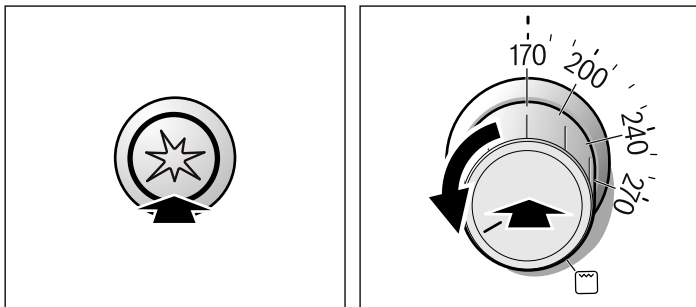

5. The gas escaping from the oven's lower gas burner is ignited using the ignition button. To activate the safety ignition, press and hold the lower gas burner on the oven for 10 seconds. The safety ignition is activated. If the gas flame goes out, the gas supply is automatically interrupted by the safety ignition system.
6. Look through the inspection port to make sure that the flame is lit. If it is not, repeat the process from step 3.
7. Close the oven door slowly.
8. Preheat the empty oven for approximately 15 minutes before baking.

9. When the dish has finished cooking, turn off the switch for the lower gas burner.

You can change the temperature at any time.

⚠ Caution:!

The ignition device should not be actuated for more than 15 seconds. If the burner does not light within 15 seconds, wait for at least one minute. Then repeat the ignition process.

Procedure for setting the gas grill

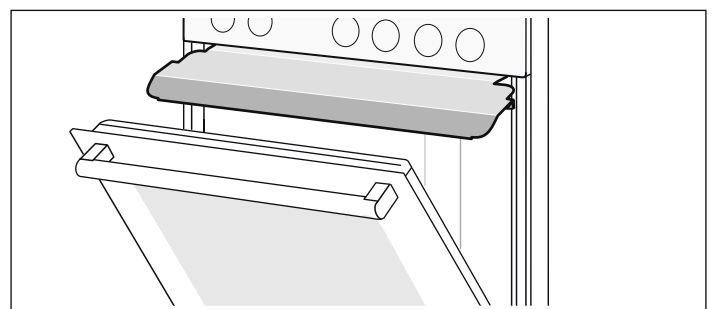

1. Open the top cover. The top cover must remain open for as long as the oven is in operation.
2. Turn on the main gas supply to the appliance. Connect the plug to the socket.
3. Insert the protecting plate into the groove under the control panel.

The protecting plate is inserted with the longer edge facing forwards and the curvature facing downwards.



Fasten the protecting plate in the groove under the control panel using the retainers.

Make sure that the protecting plate is latched into the retainers. Once the protecting plate cannot be removed, it is correctly latched in place. You can now safely use the protecting plate. If it can be removed, insert it into the groove at a slightly higher angle and make sure that it latches into the retainers.

4. Close the oven door so that it is in contact with the protecting plate.
5. Press the function selector and turn it clockwise to the grill setting .
6. Keep the function selector pressed in and simultaneously press the ignition button .

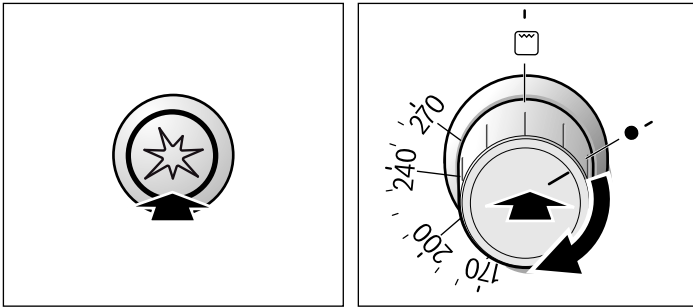

7. The gas leaving the gas grill is ignited using the ignition button. To ensure that the ignition safety system responds, press and hold the function selector for 10 seconds. The ignition safety system is activated. If the gas flame goes out, the gas supply is automatically interrupted by the ignition safety system.
8. Check whether the flame is lit. If the flame is not lit, repeat the process from step 5.
9. Once the meal is cooked, switch off the function selector. Once the oven has cooled down, remove the protecting plate.

⚠ Caution!

The ignition device should not be actuated for more than 15 seconds. If the burner does not light within 15 seconds, wait for at least one minute. Then repeat the ignition process.

Caution!

The gas grill only works when the protecting plate is inserted. Make sure that the protecting plate is correctly inserted.

Grilling with the rotary spit

The rotary spit is particularly good for cooking large roasts, such as rolled roasting joints or poultry. The meat becomes crispy and brown.

Preparing roasts

To ensure that the roast is well-browned and cooked evenly, observe the following points:

Skewering and securing the joint to the spit

Position the joint as close as possible to the centre of the rotary spit.

Use the clamps to secure it at both ends. The rear clamp must be a minimum of 7 cm from the end of the spit.

You can also truss the joint with string. With poultry, bind the ends of the wings underneath the back and the thighs against the body. This prevents them from overbrowning. Pierce the skin on the underside of the wings to allow the fat to escape.

In the section *Tables and tips*, you will find a variety of setting values for grilling with the rotary spit.

Inserting the rotary spit

1. Place the rotary spit holder on the baking tray (Fig. A).
2. Place the rotary spit in the holder (Fig. B).

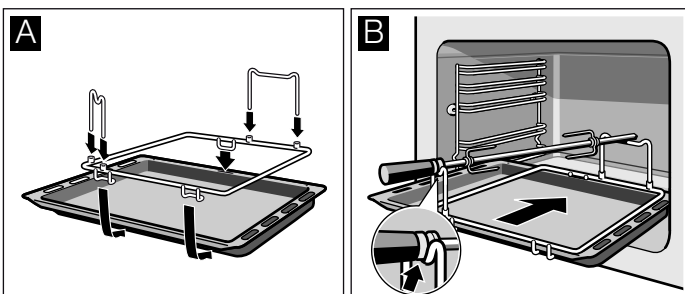

3. Insert the baking tray at level 1. There is an opening in the back wall of the oven. The rotary spit hooks into this (Fig. C).
4. Remove the handle and close the oven door (Fig. D).

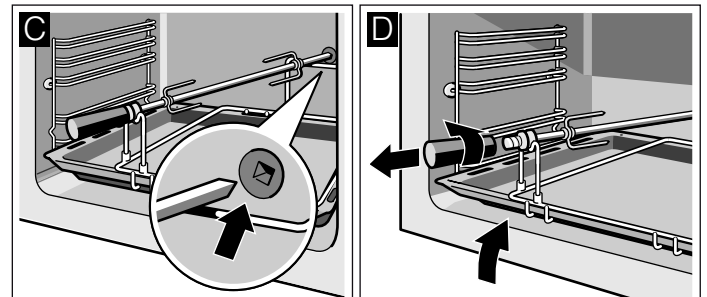

Procedure for setting the rotary spit and grill

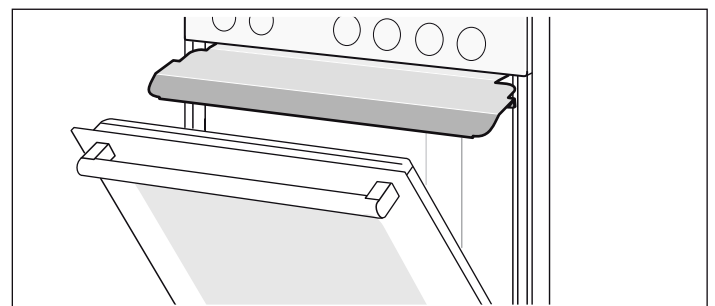

To turn on the rotary spit, follow the instructions below. First set the rotary spit and then carry out the following steps.

1. Open the top cover. The top cover must remain open for as long as the oven is in operation.
2. Turn on the main gas supply to the appliance. Connect the plug to the socket.
3. Insert the protecting plate into the groove under the control panel. The protecting plate is inserted with the longer edge facing forwards and the curvature facing downwards.



Fasten the protecting plate in the groove under the control panel using the retainers.

Make sure that the protecting plate is latched into the retainers. Once the protecting plate cannot be removed, it is correctly latched in place. You can now safely use the protecting plate. If it can be removed, insert it into the groove at a slightly higher angle and make sure that it latches into the retainers.

4. Close the oven door so that it is in contact with the protecting plate.
5. Press the function selector and turn it clockwise to the grill setting .
6. Keep the function selector pressed in and simultaneously press the ignition button .

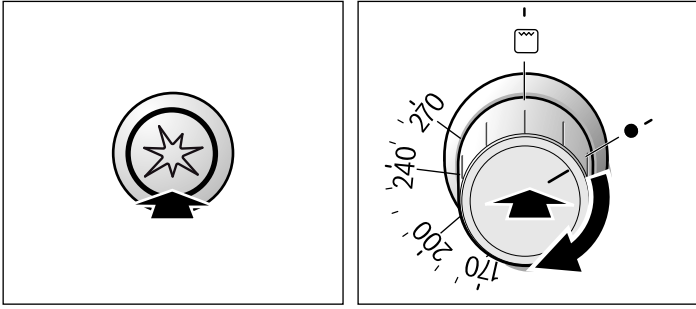

7. The gas leaving the gas grill is ignited using the ignition button. To ensure that the ignition safety system responds, press and hold the function selector for 10 seconds. The ignition safety system is activated. If the gas flame goes out, the gas supply is automatically interrupted by the ignition safety system.

8. Check whether the flame is lit. If the flame is not lit, repeat the process from step 5.
9. Press the multi-function button. The rotary spit is switched on. The oven light comes on.

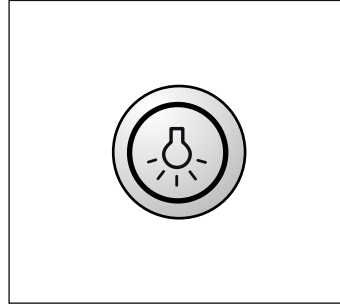

10. When the dish has finished cooking, switch the function selector off. Press the multi-function button. The rotary spit will switch off. The oven light will go out. Once the oven has cooled down, remove the protecting plate.

Caution!

The ignition device should not be actuated for more than 15 seconds. If the burner does not light within 15 seconds, wait for at least one minute. Then repeat the ignition process.

Care and cleaning

With attentive care and cleaning, your hob and oven will retain its looks and remain in good working order for a long time. We will explain here how you should care for and clean them correctly.

Notes

- Slight differences in the colours on the front of the oven are caused by the use of different materials, such as glass, plastic and metal.
- Shadows on the door panel which look like streaks, are caused by reflections made by the oven light.
- Enamel is baked on at very high temperatures. This can cause some slight colour variations. This is normal and does not affect operation. The edges of thin trays cannot be completely enamelled. As a result, these edges can be rough. This will not impair the anti-corrosion protection.

Upper glass cover

Before opening the top cover, remove any spills with a cloth.

Use glass cleaner if possible.

For cleaning, remove the top cover. To do this, hold the cover securely on both sides with both hands and pull it upwards.

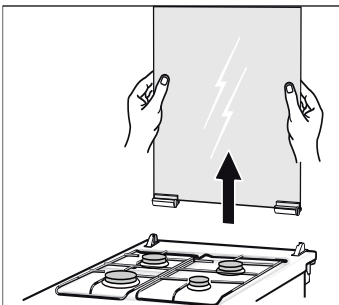

If the cover hinges become loose, note the letters marked on them. The hinge with the letter R must be fitted on the right, and the hinge with the letter L must be fitted on the left.

After cleaning, re-assemble the top cover following the same procedure in reverse order.

Only close the top cover once the burners have cooled down.

Cleaning agents

Damage to the various different surfaces caused by using the wrong cleaning agent can be avoided by observing the following instructions.

When cleaning the hob do not use

- undiluted washing-up liquid or dishwasher detergent,
- scouring pads,
- abrasive cleaning agents such as oven cleaner or stain remover,
- high-pressure cleaners or steam jets.
- Do not clean individual parts in the dishwasher.

When cleaning the oven do not use

- sharp or abrasive cleaning agents,
- cleaning agent with a high alcohol content,
- scouring pads,
- high-pressure cleaners or steam jets.
- Do not clean individual parts in the dishwasher.

Wash new sponges thoroughly before first use.

Stainless steel fronts	Wipe with some washing-up liquid and a damp cloth. Always wipe parallel to the natural grain. Otherwise, you may scratch the surface. Dry with a soft cloth. Remove flecks of limescale, grease, starch and albumin (e.g. egg white) immediately. Do not use any abrasive materials, scouring sponges or rough cleaning cloths. The stainless steel fronts can be polished using a special care product. Follow the manufacturer's instructions. You can purchase special stainless steel cleaner from our after-sales service or from specialist retailers.
Enamel surfaces and lacquered surfaces	Clean with some washing-up liquid and a damp cloth. Dry with a soft cloth.
Burners and steel grid of the gas burners	Do not clean in the dishwasher. Remove the wire rack and clean with a sponge, washing-up liquid and some hot water. Remove the burner cup and cap. Clean with a sponge and some hot water and washing-up liquid. Ensure that the gas outlets on the burner cups are clean and unobstructed. Brush the igniters with a small, soft brush. The gas burners only work properly when the igniters are clean. Remove food residue from the burner shells with some washing-up liquid and a damp cloth. Only use a little water. Water must not be allowed to enter the appliance. Ensure that the nozzle opening does not become blocked or damaged during cleaning. Dry all parts after cleaning and place the burner cover accurately on the burner cup. If the parts are not positioned accurately, it will be harder to ignite the burner. The burner covers are coated with black enamel. Due to the high temperatures, discolouration may occur. This will not impair the function of the burner. Replace the wire rack in the oven.
Electric hob (option)	Clean with the hard side of a scouring sponge and some liquid scouring agent. After cleaning, switch the hob on briefly to dry it. Wet hobs rust over time. Then apply a care product. Always remove spilt liquids and food residue immediately.
Metal ring of the electric hob (option)	The metal ring may discolour with time. However, it is possible to restore the original colour. Clean the ring with the hard side of a scouring sponge and some liquid scouring agent. When doing so, make sure that you do not scour the adjacent surfaces, as this could damage them.
Knobs	Clean with some washing-up liquid and a damp cloth. Dry with a soft cloth.
Door glass	Can be cleaned with glass cleaner. Do not use any abrasive cleaning agents or sharp metal objects. These could scratch and damage the surface of the glass panel.
Seal	Wipe with a damp cloth. Dry with a soft cloth.
Oven interior	Clean with hot water or vinegar solution. For heavy soiling: Only use oven cleaner on cold surfaces.
Glass cover on the oven light	Clean with some washing-up liquid and a damp cloth. Dry with a soft cloth.
Accessories	Soak in hot soapy water. Clean with a brush or a sponge.
Aluminium baking tray (option)	Do not clean in the dishwasher. Never use oven cleaner. To avoid scratches, never touch the metal surfaces with a knife or similar sharp object. Wipe the surfaces horizontally and without applying pressure with soapy water and a soft window cloth or a lint-free microfibre cloth. Dry with a soft cloth. Do not use any abrasive materials, scouring sponges or rough cleaning cloths. They could scratch the baking tray.
Childproof lock (option)	If a childproof lock has been fitted on the oven door, it must be removed before cleaning. Soak all plastic parts in hot soapy water and wash with a sponge. Dry with a soft cloth. If very dirty, the childproof lock will not work properly.
Plinth drawer (option)	Clean with some washing-up liquid and a damp cloth. Dry with a soft cloth.
Accessories	Soak in hot soapy water. Clean with a brush or sponge.

Detaching and refitting the rails

The rails can be removed for cleaning. The oven must have cooled down.

Detaching the rails

1. Lift up the front of the rail
2. and unhook it (figure A).
3. Then pull the whole rail forward
4. and remove it (Fig. B).

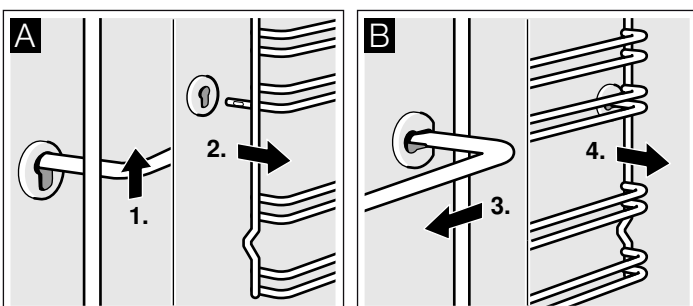

Refitting the rails

1. First insert the rail into the rear socket, press it to the back slightly (figure A),
2. and then hook it into the front socket (figure B).

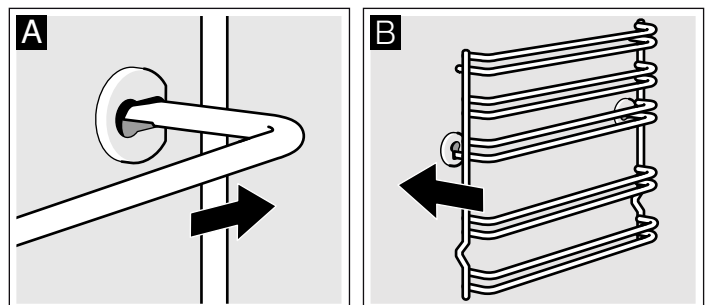

The rails fit both the left and right sides. Ensure that, as shown in figure B, levels 1 and 2 are below and levels 3, 4 and 5 are above.

Clean the rails with cleaning agent and a sponge. For stubborn deposits of dirt, use a brush.

Detaching and attaching the oven door

For cleaning purposes and to remove the door panels, you can detach the oven door.

The oven door hinges each have a locking lever. When the locking levers are closed (figure A), the oven door is secured in place. It cannot be detached. When the locking levers are open in order to detach the oven door (Fig. B), the hinges are locked. They cannot snap shut.

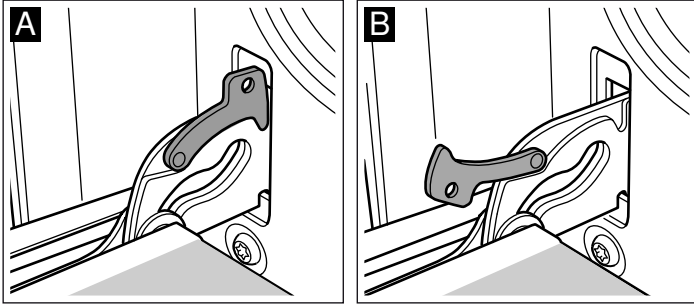

⚠ Risk of injury!

Whenever the hinges are not locked, they snap shut with great force. Ensure that the locking levers are always fully closed or, when detaching the oven door, fully open.

Detaching the door

1. Open the oven door fully.
2. Fold up the two locking levers on the left and right (figure A).
3. Close the oven door as far as the limit stop. With both hands, grip the door on the left and right-hand sides. Close the door a little further and pull it out (figure B).

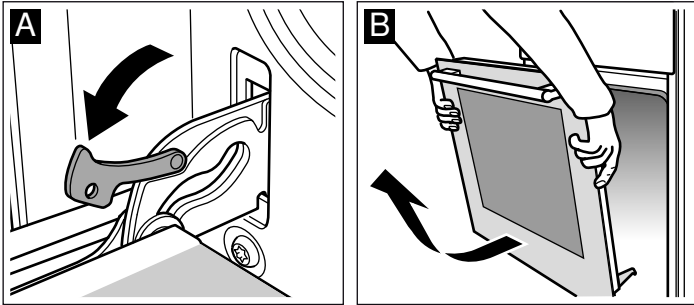

Attaching the door

Reattach the oven door in the reverse sequence to removal.

1. When attaching the oven door, ensure that both hinges are inserted straight into the opening (figure A).
2. The notch on the hinge must engage on both sides (figure B).

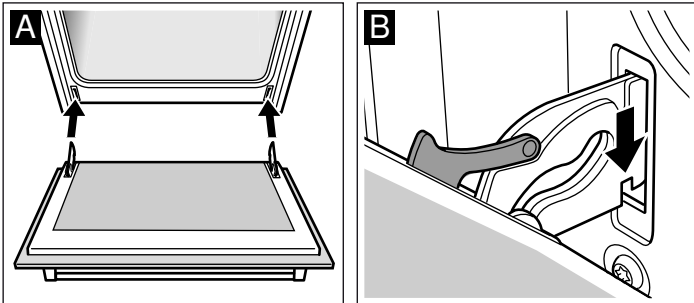

3. Fold back both locking levers (figure C). Close the oven door.

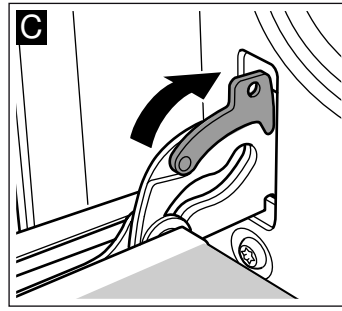

⚠ Risk of injury!

If the oven door falls out accidentally or a hinge snaps shut, do not reach into the hinge. Call the after-sales service.

Removing and installing the door panels

To facilitate cleaning, you can remove the glass panels from the oven door.

Removal

1. Detach the oven door and lay it on a cloth with the handle facing down.
2. Pull off the cover at the top of the oven door. Press in the tabs on the left and right using your fingers (fig. A).
3. Lift the top panel up and pull it out (fig. B).

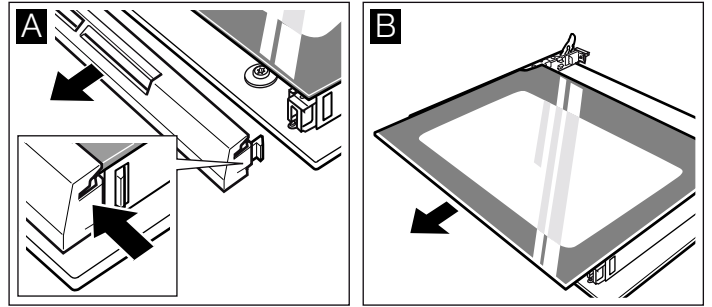

4. Lift the panel up and pull it out (fig. C).

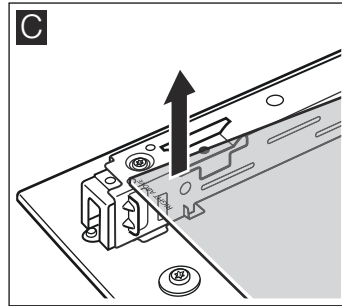

Clean the panels with glass cleaner and a soft cloth.

⚠ Risk of injury!

Scratched glass in the appliance door may develop into a crack. Do not use a glass scraper, sharp or abrasive cleaning aids or detergents.

Installation

During installation, make sure that the lettering "top right" is upside down at the bottom left.

1. Insert the panel at an angle towards the back (fig. A).
2. Insert the top panel at an angle towards the back into the brackets. The smooth surface must face outwards. (fig. B).

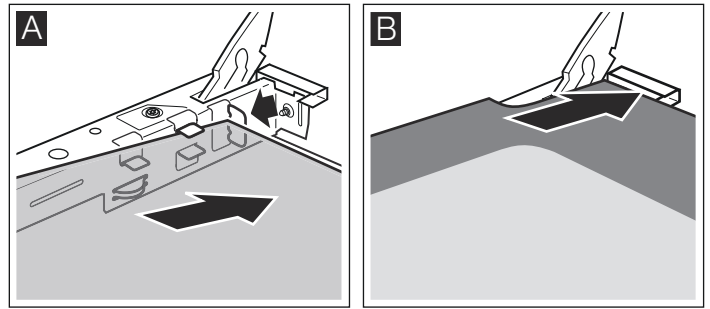

3. Put the cover back in place and press on it.
4. Attach the oven door.

Do not use the oven again until the panels have been correctly installed.

Troubleshooting

Malfunctions often have simple explanations. Refer to the table before calling the after-sales service as you may be able to remedy the fault yourself.

Fault table

If a dish does not turn out as well as you had hoped, refer to the chapter: *Tested for you in our cooking studio*. It contains useful tips and information on cooking, baking and roasting.

⚠ Risk of electric shock!

Incorrect repairs are dangerous. Repairs may only be carried out by one of our trained after-sales engineers.

Fault	Possible cause	Troubleshooting/information
The oven does not work.	Faulty circuit breaker	Look in the fuse box and check that the circuit breaker is in working order.
	Power cut.	Check whether the kitchen light or other kitchen appliances are working.
Oven not hot.	Dust on the contacts.	Turn the control knobs clockwise and anti-clockwise a few times.
The burner does not ignite.	Power cut or damp ignition plugs.	Light the gas burner with a gas lighter or a match.
The gas grill does not work.	The protecting plate is incorrectly inserted.	Make sure that the protecting plate is correctly inserted. Remove the protecting plate and reinsert it.

Replacing the bulb in the oven ceiling light

If the bulb in the oven light fails, it must be replaced. Heat-resistant, 25 watt spare bulbs can be obtained from our after-sales service or a specialist retailer. Only use these bulbs.

⚠ Risk of electric shock!

Switch off the circuit breaker in the fuse box.

1. Place a tea towel in the cold oven to prevent damage.
2. Unscrew the glass cover by turning it anti-clockwise.

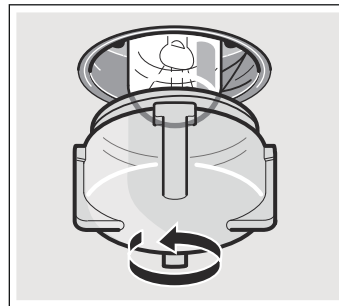

3. Replace the bulb with one of the same type.
4. Screw the glass cover back in.
5. Remove the tea towel and switch on the circuit breaker.

Glass cover

You must replace a damaged glass cover. Suitable glass covers may be obtained from the after-sales service. Please specify the E number and FD number of your appliance.

After-sales service

Our after-sales service is there for you if your appliance needs to be repaired. We will always find the right solution in order to avoid unnecessary visits from a service technician.

E number and FD number

When calling us, please give the product number (E no.) and the production number (FD no.) so that we can provide you with the correct advice. The rating plate containing these numbers is found on the side of the oven door. To save time, you can make a note of the number of your appliance and the telephone number of the after-sales service in the space below, should it be required.

E no.	FD no.
After-sales service 	

Please note that there will be a fee for a visit by a service technician in the event of a malfunction, even during the warranty period.

Please find the contact data of all countries in the enclosed customer service list.

To book an engineer visit and product advice

- GB** 0844 8928979
Calls from a BT landline will be charged at up to 3 pence per minute. A call set-up fee of up to 6 pence may apply.
- IE** 01450 2655
0.03 € per minute at peak. Off peak 0.0088 € per minute.

Rely on the professionalism of the manufacturer. You can therefore be sure that the repair is carried out by trained service technicians who carry original spare parts for your appliances.

Energy and environment tips

Here you can find tips on how to save energy when baking and roasting in the oven and when cooking on the hob, and how to dispose of your appliance properly.

Saving energy

- Only preheat the oven if this is specified in the recipe or in the tables in the instruction manual.
- Use dark, black lacquered or enamelled baking tins, because they absorb heat particularly well.
- Open the oven door as infrequently as possible while the food is baking and roasting.
- For longer cooking times, the oven can be turned off 10 minutes before the end of the cooking time, and the meal can be finished using residual heat.

Saving energy with the gas hob

- Always use a saucepan which is the correct size for your food. A larger, less full saucepan requires a lot of energy.
- Always place a suitable lid on the saucepan.
- The gas flame must always be in contact with the base of the saucepan.

Environmentally-friendly disposal

Dispose of packaging in an environmentally-friendly manner.



This appliance is labelled in accordance with European Directive 2012/19/EU concerning used electrical and electronic appliances (waste electrical and electronic equipment - WEEE). The guideline determines the framework for the return and recycling of used appliances as applicable throughout the EU.

Tested for you in our cooking studio.

Here you will find a selection of dishes and the ideal settings for them. We will show you which type of heating and which temperature are best suited for your dish. You can find information about suitable accessories and the height at which they should be inserted. There are also tips about cookware and preparation methods.

Notes

- The values in the table apply to dishes placed into the cooking compartment when it is cold and empty.
Only preheat the appliance if the table specifies that you should do so. Line the accessories with greaseproof paper before preheating.
- The times specified in the tables are guidelines only. They will depend on the quality and composition of the food.
- Use the accessories supplied. Additional accessories may be obtained as special accessories from specialist retailers or from the after-sales service.
Before using the appliance, remove all accessories from the cooking compartment that you will not be using.

- Always use oven gloves when taking hot accessories or ovenware out of the cooking compartment.
- Your oven is suitable for baking on one level.

Caution!

The appliance was manufactured to suit the reference gases specified in the standards. If a gas is used which does not comply with the specified gas mixture and pressure, cooking performance and heat output may not produce the desired result.

Name of the gas	Gas mixture (%)
G20	CH ₄ = 100
G25	CH ₄ = 86, N ₂ = 14
G30	n-C ₄ H ₁₀ = 50, i-C ₄ H ₁₀ = 50

Cakes and pastries

Cake tins

When you are baking in the cake tin, insert the wire rack at the level indicated and place the cake tin on the wire rack.

Dark-coloured cake tins are the most suitable.

If you use light-coloured baking tins or glass, the baking time increases and the cake is not browned evenly.

Only use heat-resistant glass dishes. Do not place a hot glass dish on a cold or wet surface. The glass could break.

If you want to use silicone moulds, follow the guidelines in the manufacturer's instruction manual. Silicone moulds turn out slightly smaller than normal cake tins. For this reason, the

quantities may be slightly different to those indicated in your recipe.

Baking tables for the lower burner in the gas oven

In the tables, you will find the optimum types of heating for a selection of cakes and gateaux. The temperature and cooking times depend on the quantity and consistency of the dough.

The values in the table apply to dishes placed into the cooking compartment when it is cold and empty.

The heat is distributed in the oven as soon as the gas escaping from the lower gas burner is ignited. For this reason, the underside of food is usually more browned than the top.

Cake in a mould	Accessories	Level	Temperature in °C (lower gas burner on the oven)	Cooking time in minutes
Cakes	Round springform cake tin with tube sheet, deep	2	180	60-80
Cakes	Round springform cake tin with tube sheet, wide	3	180	60-80
Sponge cake	Springform cake tin (dia. 26 cm)	2	180	50-60
Apple pie	Springform cake tin, light (dia. 20 cm)	2	230	60-80
Semolina cake	Glass ovenproof dish, rectangular	3	180	60-80

Several small baked items on the baking sheet	Accessories	Level	Temperature in °C (lower gas burner on the oven)	Cooking time in minutes
Small cakes	Baking sheet	4	170	70-90
Biscuits	Baking sheet	3	180	40-60
Sesame seed rings	Baking sheet	4	190	60-80
Puff pastry strudel	Baking sheet	4	180	50-70
Yufka dough strudel	Baking sheet	3	190	60-80
Yeast-risen pastry	Baking sheet	4	170	70-90
Pizza	Baking sheet	3	190	50-70

Dish	Accessories and oven-ware	Level	Temperature in °C	Cooking time in minutes
Pasta bake	Glass ovenproof dish, rectangular*	2	190	60-80
Potato gratin made using raw ingredients, Max. 4 cm deep	Glass ovenproof dish, rectangular*	2	180	60-80
Vegetable goulash	Earthenware pot	2	220	80-100

* Only use heat-resistant glass dishes. Do not place a hot glass dish on a cold or wet surface. The glass could break.

Baking tips

You wish to bake according to your own recipe. Use similar items in the baking tables as a guide.

How to tell whether sponge cake is baked through: Approx. 10 minutes before the end of the baking time stated in the recipe, insert a cocktail stick into the cake at its deepest point. If the cocktail stick comes out clean, the cake is ready.

The cake collapses. Next time, add less liquid. Observe the specified mixing times in the recipe.

The cake has risen in the middle but is lower around the edge. Do not grease the edge of the springform cake tin. After baking, loosen the cake carefully with a knife.

The cake is too dry. Make tiny holes in the finished cake using a cocktail stick. Then drizzle fruit juice or an alcoholic drink over it. Next time, reduce the baking time.

The bottom of a fruit cake is too light. Place the cake one level lower the next time.

The fruit juice overflows. Next time, use the deeper universal pan (if available).

The pieces of dough are sticking together when the yeast rolls are baked. There must be a distance of about 2 cm between the bread rolls. This gives enough space for the bread rolls to expand and bake evenly on all sides.

Condensation forms when you bake moist cakes. Steam can form during baking, which escapes via the door. The steam may settle and form water droplets on the control panel or on the fronts of adjacent units. This is a natural process.

Meat, poultry, fish, toast

Table for the gas grill

The values in the table apply to dishes placed in a cold oven.











After $\frac{2}{3}$ of the cooking time, turn the pieces of meat over.

Always place the meal in the middle of the wire rack.

If you are grilling directly on the wire rack, you should insert the baking tray at level 1. The fish juices are collected in the pan and the oven is kept cleaner.

The rotary spit is particularly good for cooking large roasts, rolled roasting joints or poultry. The meat becomes crispy and brown.

In the section *Grilling with the rotary spit*, you will find the instructions for operating the rotary spit.

Dish	Weight	Accessories and oven-ware	Level	Type of heating	Cooking time in minutes
Meat					
Steaks, (2 pieces, 3 cm thick)	0.5 kg	Wire rack	4		30-40
Hamburgers (6 slices)	0.3 kg	Wire rack	4		10-20
Sausages (5 pieces)	0.2 kg	Wire rack	4		10-20
Skewered meat	1.0 kg	Rotary spit	1		90-110
Poultry					
Chicken drumsticks (4 pieces)	1.5 kg	Wire rack	4		40-50
Poultry	1.5 kg	Rotary spit	1		80-90
Duck	2.0 kg	Rotary spit	1		80-100
Fish					
Fish, whole (2 pieces)	1.0 kg	Wire rack	4		35-45
Fish fillets (4 pieces)	0.5 kg	Wire rack	4		35-45
Toast					
Toasts, browned (4 slices)	-	Wire rack	4		2-4
Toasts with filling, browned from above (4 slices)	-	Wire rack	4		3-5

Tips for roasting and grilling

The table does not contain information for the weight of the joint.	Select the next lowest weight from the instructions and extend the time.
How to tell when the roast is ready.	Use a meat thermometer (available from specialist shops) or carry out a "spoon test". Press down on the roast with a spoon. If it feels firm, it is ready. If the spoon can be pressed in, it needs to be cooked for a little longer.
The roast is too dark and the crackling is partly burnt.	Check the shelf height and temperature.
The roast looks good but the juices are burnt.	Next time, use a smaller roasting dish or add more liquid.
The roast looks good but the juices are too clear and watery.	Next time, use a larger roasting dish and use less liquid.
Steam rises from the roast when basted.	This is normal and due to the laws of physics. The majority of the steam escapes through the steam outlet. It may settle and form condensation on the cooler switch panel or on the fronts of adjacent units.

Acrylamide in foodstuffs

Acrylamide is mainly produced in grain and potato products heated at high temperatures, such as potato crisps, chips,

toast, rolls, bread, baked goods made from shortcrust pastry (biscuits, gingerbread, cookies).

Recommendations for baking, roasting and grilling with low acrylamide values

General	<ul style="list-style-type: none"> ■ Keep cooking times to a minimum. ■ Cook the food until it is golden brown. "Browned, not charred". ■ The larger and thicker the food, the less acrylamide it contains.
Oven chips	Where possible, spread out a single layer of oven chips evenly on the baking tray. To prevent the chips from trying out quickly, cook at least 400 g on the baking tray.



Robert Bosch Hausgeräte GmbH

Carl-Wery-Straße 34

81739 München

Germany

www.bosch-home.com



9000986605