

HEZ 395600 60cm
HEZ 395800 80cm

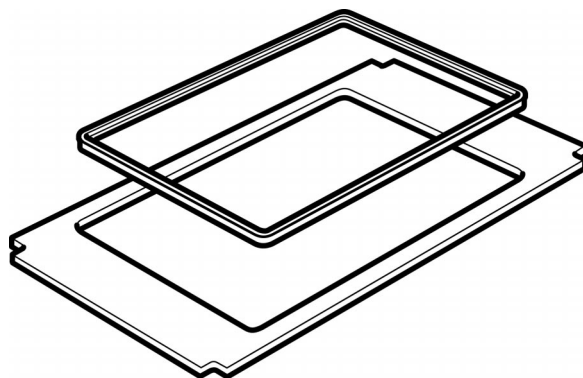

1A

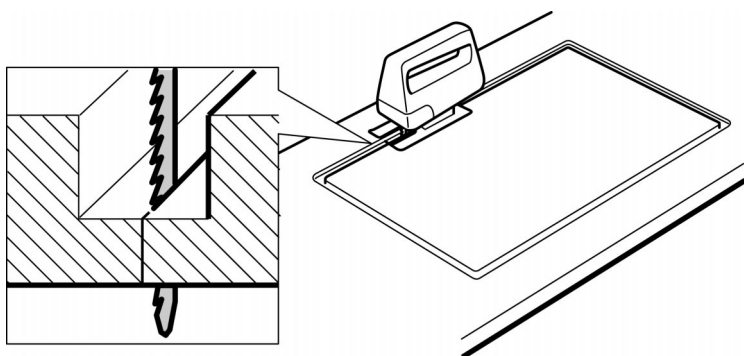
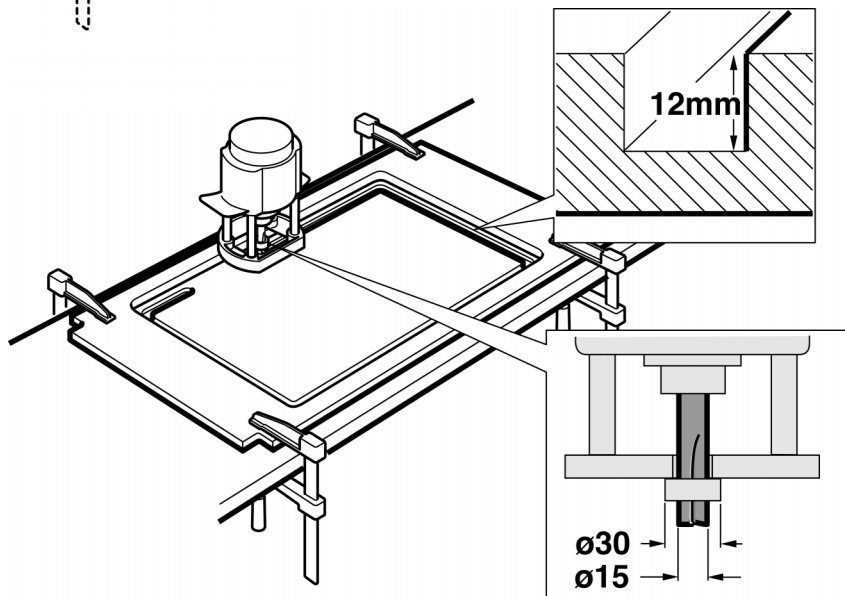
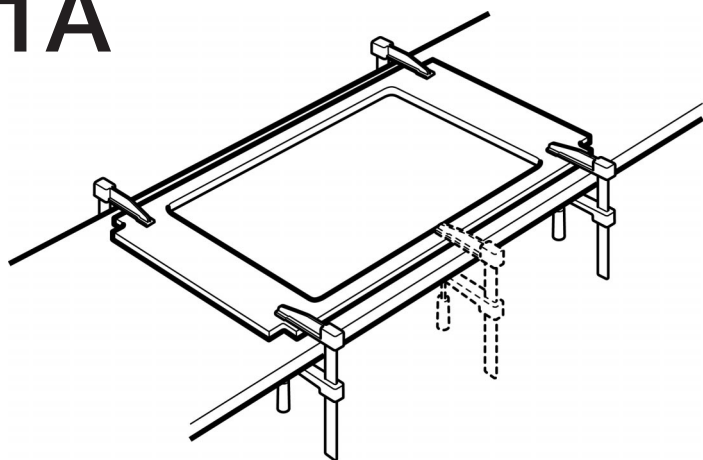

1B

0,5mm-0,2mm

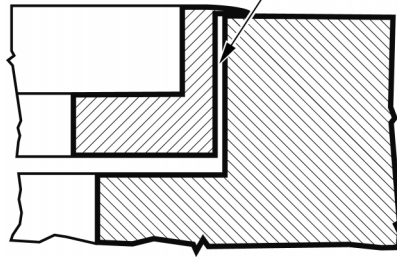

60cm

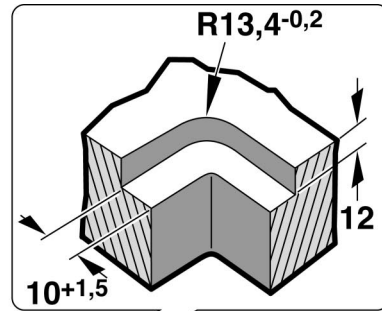
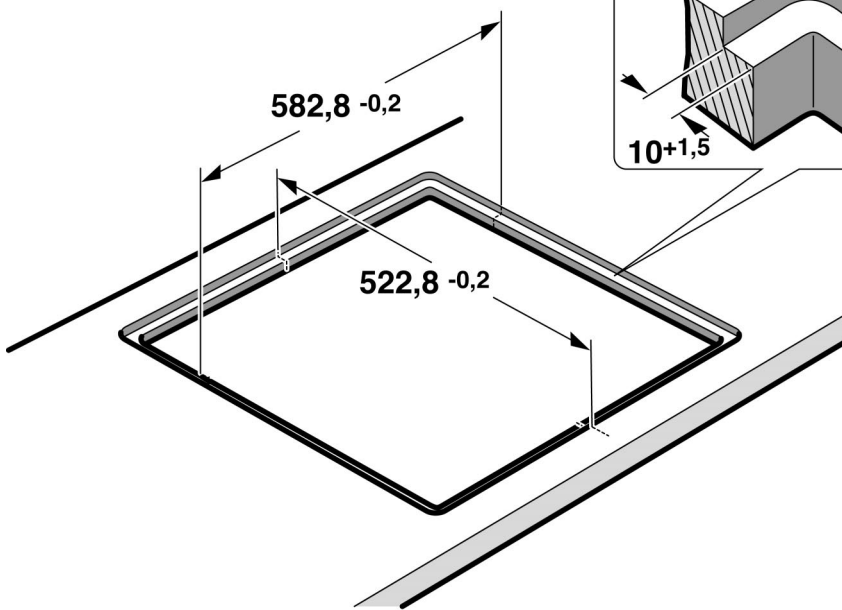

80cm

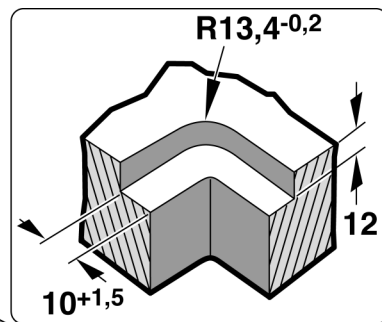
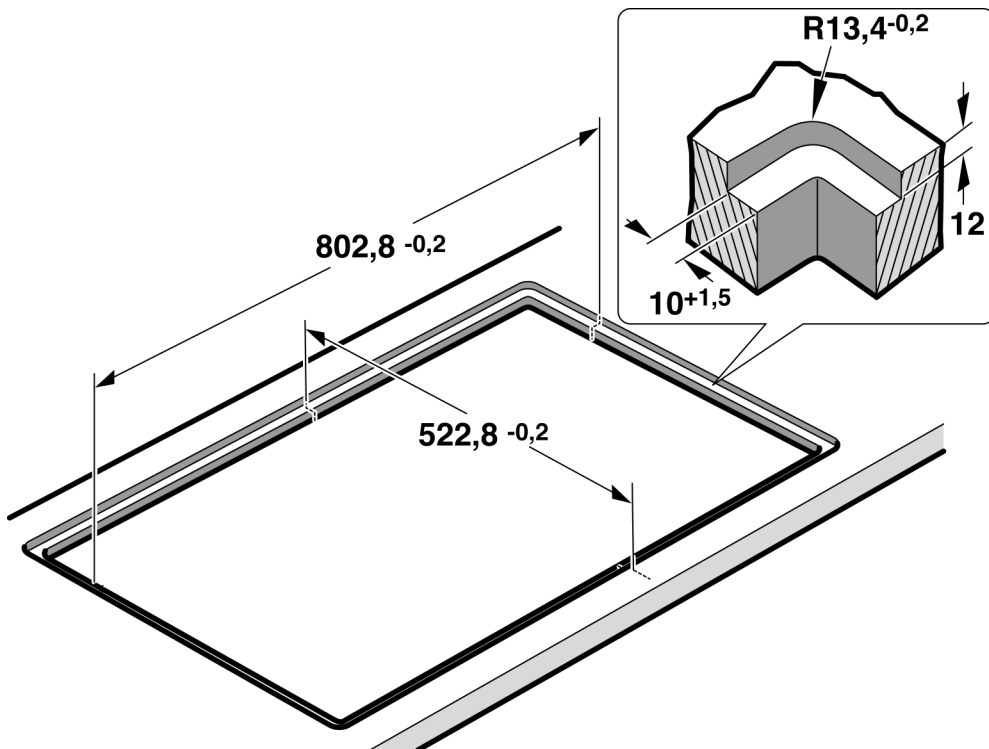

2

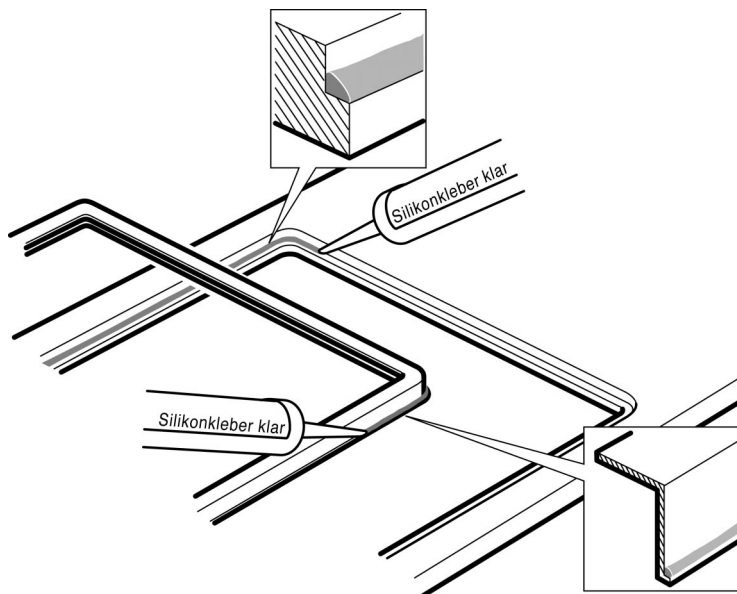
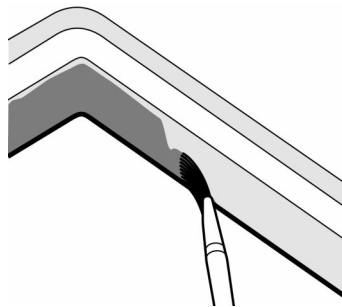

3

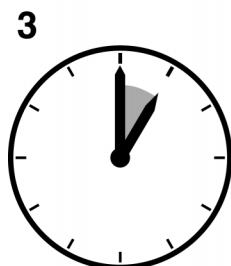
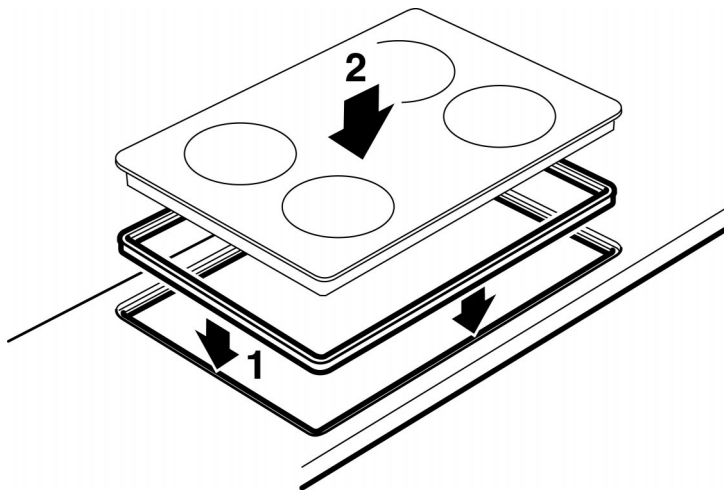

4

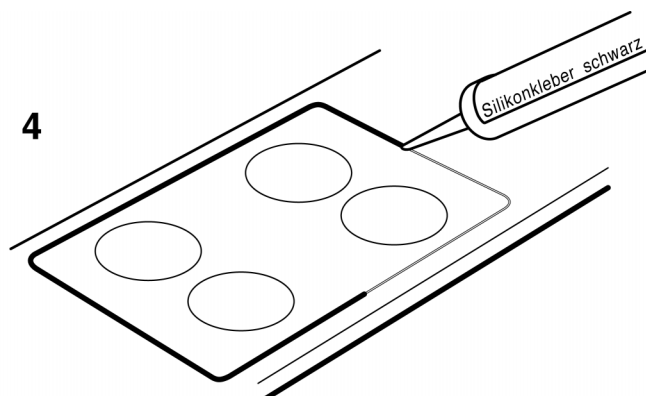

de**Arbeitplatte ausschneiden
– Bild 1**

Montageanweisung des Kochfeldes beachten.

A Für Oberfräse:

Schablone benutzen:

60cm = HEZ395601

80cm = HEZ395801

B Für Fräsmaschine**Einbau vorbereiten – Bild 2**

Schnittfläche hitzebeständig versiegeln.

Klaren Silikonkleber auftragen.

Gerät montieren – Bild 3

Rahmen einsetzen.

Gerät einsetzen.

60 Minuten aushärten lassen.

Mit schwarzem Silikonkleber versiegeln.

fr**Découper le plan de travail
- fig. 1**

Respecter la notice de montage de la table de cuisson.

A Pour défonceuse :

Utiliser le gabarit :

60cm = HEZ395601

80cm = HEZ395801

B Pour fraiseuse**Préparer l'encastrement - fig. 2**

Sceller la face coupée de façon thermostable.

Appliquer une colle silicone claire.

Monter l'appareil - fig. 3

Insérer le cadre.

Insérer l'appareil.

Laisser durcir 60 minutes.

Sceller avec de la colle silicone noire.

nl**Werkblad uitsnijden
- afb. 1**

Montage-instructies kookveld aanhouden.

A voor bovenfrezen:

Sjabloon gebruiken:

60cm = HEZ395601

80cm = HEZ395801

B Voor freesmachine**Inbouw voorbereiden - afb. 2**

Snijvlak hittebestendig sealen.

Transparante siliconenkit opbrengen.

Apparaat monteren - afb. 3

Frame plaatsn.

Apparaat plaatsn.

60 minuten laten uitharden.

Met zwarte siliconenkit sealen.

en**Cutting out the worktop - fig. 1**

Observe the installation instructions for the hob.

A for the router:

Use the template:

60cm = HEZ395601

80cm = HEZ395801

B for the milling machine**Preparing the installation - fig. 2**

Seal the cut surface to make it heat-resistant.

Apply clear silicon adhesive.

Fitting the appliance - fig. 3

Insert the frame.

Insert the appliance.

Leave to bond for 60 minutes.

Seal with black silicon adhesive.

it**Taglio del piano di lavoro
- Figura 1**

Rispettare le istruzioni di montaggio del piano di cottura.

A Per fresatrice verticale:

Utilizzare mascherina:

60cm = HEZ395601

80cm = HEZ395801

B Per fresatrice**Preparazione del montaggio - Figura 2**

Sigillare le superfici di taglio in modo refrattario.

Applicare un adesivo a base di silicone chiaro.

Montaggio dell'apparecchio - Figura 3

Montare l'intelaiatura.

Montare l'apparecchio.

Lasciare asciugare per 60 minuti.

Sigillare con un adesivo a base di silicone nero.