



EN Instruction manual



**BOSCH**

# Table of contents

<b>Important information</b> .....	<b>6</b>
Before installation .....	6
Safety information .....	6
Reasons for damage .....	7
<b>Your new oven</b> .....	<b>8</b>
The control panel .....	8
Control panels and displays .....	9
Arrows for selecting the type of heating .....	10
Symbols for adjusting the values set .....	11
Types of heating .....	11
Oven carriage and shelving accessories .....	14
Cooling fan .....	15
<b>Before using for the first time</b> .....	<b>15</b>
Heating up the oven .....	16
Pre-cleaning the accessories .....	16
<b>Switching the oven on and off</b> .....	<b>16</b>
Main Sensor .....	16
<b>Setting the oven</b> .....	<b>17</b>
Setting procedure .....	17
You want the oven to switch off automatically .....	19
You want the oven to switch on and off automatically .....	20
Residual heat indicator .....	21
<b>Rapid heating</b> .....	<b>22</b>
<b>Automatic programme</b> .....	<b>23</b>
How long will the meal take to cook? .....	23
Setting procedure .....	24

# Table of contents

---

You want the oven to switch on and off automatically .....	25
<b>Time .....</b>	<b>26</b>
Setting procedure .....	26
<b>Timer .....</b>	<b>27</b>
Setting procedure .....	27
<b>Basic settings .....</b>	<b>28</b>
Changing the basic settings .....	29
<b>Child-proof lock .....</b>	<b>30</b>
<b>Automatic time limiter .....</b>	<b>30</b>
<b>Care and cleaning .....</b>	<b>31</b>
Oven exterior .....	31
Oven .....	31
Cleaning function .....	32
Seal .....	33
Accessories .....	33
Cleaning the glass panels .....	34
<b>Troubleshooting .....</b>	<b>36</b>
Replacing the oven light .....	37
<b>After-sales service .....</b>	<b>39</b>
<b>Packaging and old appliances .....</b>	<b>40</b>
<b>Tables and tips .....</b>	<b>40</b>
Cakes and pastries .....	40
Baking tips .....	42
Meat, poultry, fish .....	43
Tips for roasting and grilling .....	46
Bakes, gratins, toast .....	47

## Table of contents

Frozen foods .....	47
Slow cooking .....	48
Tips on slow cooking .....	50
Special meals .....	50
Defrosting .....	51
Drying .....	51
Preserving .....	52
Energy saving tips .....	54
<b>Acrylamide in food .....</b>	<b>54</b>
What can you do? .....	55
<b>Test dishes .....</b>	<b>56</b>

---

# Important information

Read this instruction manual carefully. Only then will you be able to operate your cooker safely and correctly. The manufacturer does not accept any responsibility if the instruction manual is not followed.

Please keep the instruction and installation manual in a safe place. Please pass on the instruction manual to the new owner if you sell the appliance.

---

## Before installation

### Transport damage

Check the appliance after unpacking it. Do not connect the appliance if it has been damaged in transport.

### Electrical connection

The cooker may only be connected by an approved specialist. Losses resulting from damage caused by incorrect connection will invalidate warranty claims.

Before using the appliance for the first time, you must ensure that the domestic electrical system is earthed and meets all the current safety regulations. An authorized electrician should install and connect your appliance.

Use of this appliance without an earth connection or incorrectly installed can cause serious injuries (injuries or electrocution), although this is very rare

The manufacturer does not accept any responsibility for any inappropriate use or for any injury caused by incorrect electrical installation.

---

## Safety information

This appliance is intended for domestic use only. Only use the cooker for food preparation.

The oven door must remain closed when the oven is switched on.

## Hot oven

Carefully open the oven door. The oven may let out steam.

Never touch the oven's inner surfaces or heater elements. Danger of burning!

Children must never be allowed close to the oven. Its accessible parts may heat up while working.

Never store combustible items in the oven. Risk of fire

Never clamp leads of electrical appliances in the hot oven door. The insulation on the leads could melt.

There is a risk of short-circuiting.

## Repairs

Incorrectly done repairs are dangerous. There is a risk of electrocution.

Repairs may only be carried out by after-sales service technicians who have been fully trained by us.

In case of malfunction, disconnect the appliance from the mains.

Call the after-sales service.

---

## Reasons for damage

### Baking sheet or aluminium foil on the oven floor

Do not place baking sheets on the oven floor. Do not line the oven floor with aluminium foil.

This causes heat to accumulate. Baking and roasting times will no longer be correct and the enamel will be damaged.

### Water in the oven

Never pour water directly into a hot oven. This could damage the enamel.

### Fruit juice

When baking very moist fruit cakes, do not put too much on the baking sheet. Fruit juice dripping from the baking sheet leaves stains that cannot be removed.

### Opening the oven door

Cooking produces a lot of steam inside the oven, so when you open the oven door to take the food out, be careful because the steam is very hot and can burn. We recommend that, when you open the door, you wait a few moments to let the steam out before handling the trays inside.

### Cooling with the oven carriage open

Only leave the oven to cool with the door closed. Even if you only leave the oven carriage open slightly, the fronts of adjacent units may become damaged over time.

### Very dirty oven seal

If the oven seal is very dirty, the oven carriage will no longer close properly when the oven is in use. The fronts of adjacent units could be damaged. Keep the oven seal clean.

### Using the oven carriage as a seat

Do not stand or sit on the open oven carriage.

---

## Your new oven

Here you will be able to get to know your new appliance. We will explain the operation of the controls to you in order to use the appliance correctly. You will receive information on the types of heating and the extras supplied.

---

## The control panel

Details vary according to the appliance model.

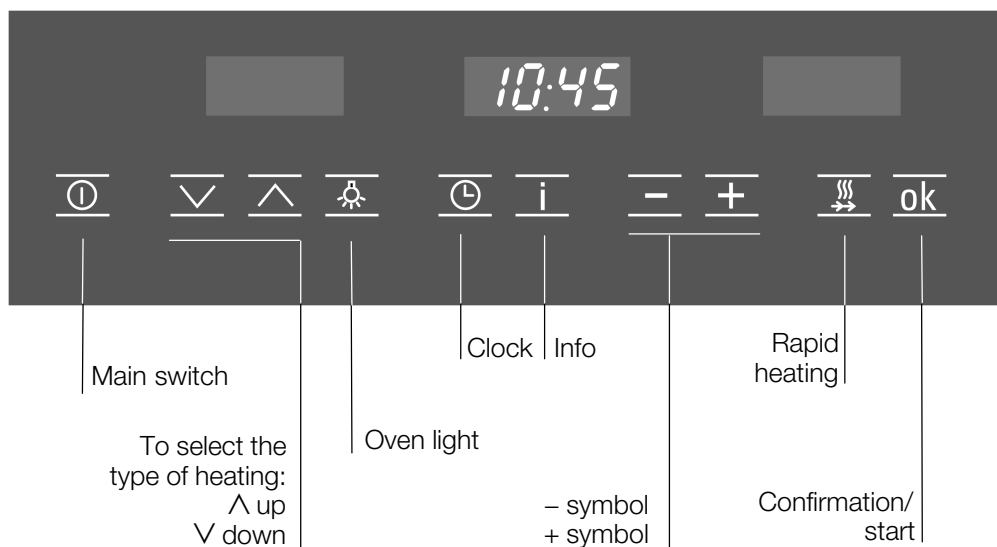

## Control panels and displays

There are sensors underneath the individual control panels. Touch the relevant symbol with your index finger.

Symbol		
ⓘ	Main switch	This is used to switch the oven on and off.
^ v	Arrows for selecting the type of heating	Use these arrows to select the type of heating:
💡	Oven light	Use this symbol to switch the oven light on and off.
🕒	Clock	Use this symbol to set the time, the timer ⏰, the duration ⏪ and the end time ⏩.
i	Info	You can use this symbol to call up the heating temperature and the weight set for the automatic program.
- +	Symbols for adjusting the values set	Use these symbols to adjust the default values and values set: - symbol = to set a lower value + symbol = to set a higher value
⚡	Rapid heating	Use this symbol to heat up the oven quickly.
OK	Confirmation/ start	Use this symbol to confirm a setting or to start the oven.

The values set can be seen in the display. Settings can be made as long as a symbol in the display is flashing.

### Important

The setting will be cleared after a few minutes if you do not start the oven using the OK symbol. Always start the oven using the OK symbol.

The rise in temperature or the residual heat in the oven is shown in the preheating indicator below the temperature display.

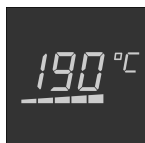

## Arrows for selecting the type of heating







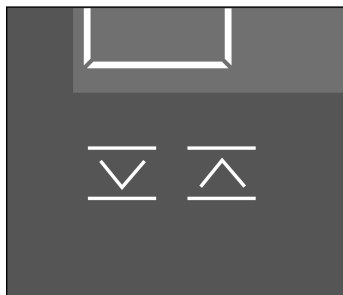

Select the type of heating for the oven using the ∇ down or ▲ up arrows.

Touch the relevant arrow until the required type of heating appears in the display.

A default value for each type of heating appears in the temperature display.



### Settings

	Top/bottom heating
	Intensive heat
	Hot air
	Intensive hot air
	Bottom heating
	Hot air grilling
	Radiant grill - small area
	Radiant grill - large area
	Defrost
clean	Cleaning
P	Automatic program

## Oven light

The oven light switches on when you select a type of heating.

Exception:

The light does not come on during defrosting at temperatures between 30 and 60 °C.

If the oven is set to switch on and off automatically, the oven light will only come on after the oven is switched on.

You can switch the light off and on again using the  oven light symbol.

Exception: Defrosting at 20 °C.

## Symbols for adjusting the values set



You can adjust all default values and values set using the + symbol or – symbol.

+ = to set a higher value

– = to set a lower value

### Ranges

50 - 270	Temperature in °C
	Defrost at temperatures between 20 and 60 °C
1 - 3	Cleaning levels
1 min - 23.59 h	Duration
1 sec - 23.55 h	Timer period
P 1 - P 14	Programs

## Types of heating

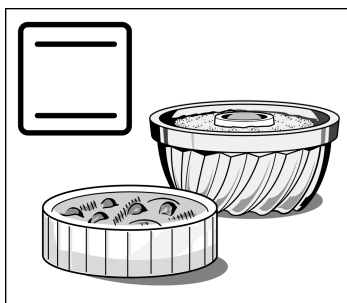

Different types of oven heating are available. You can therefore select the best method for cooking any dish.

### Top and bottom heating

This ensures the even distribution of heat onto the cake or roast from the top and bottom of the oven.

This type of heating is best for cake mixtures in tins or for bakes. Top and bottom heating is also suitable for cooking lean roasts of beef, veal and game.

Gentle cooking in the 70 °C to 100 °C temperature range makes all tender meat particularly juicy.

To keep food warm : You can keep food warm in the 65-100 °C temperature range. Do not keep food warm for longer than two hours.

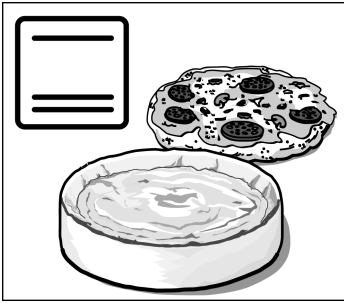

### Intensive heat

Due to the intensive heat from below, foods such as pizza will acquire a particularly crispy base. It is no longer necessary to preheat the oven to bake spiced cakes and savoury pies such as quiche lorraine. Intensive heat is also the ideal type of heating when baking in moulds made from tin, glass or porcelain, which tend to reflect heat or are poor conductors of heat.

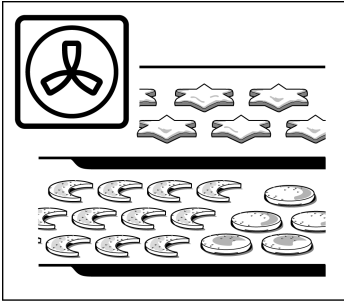

### Hot air

A cooling fan in the oven's back wall distributes the heat in a uniform manner throughout the oven. Using hot air, it is possible to bake cakes and pizza on two shelves. When cooking on two levels, place the aluminium tray on the lower level. Additional trays may be purchased from a specialist shop. The required oven temperatures are lower than those for top/bottom heating. Hot air is ideal for drying food.

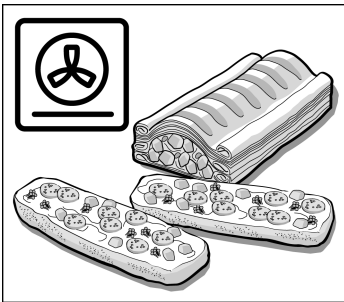

### Pizza setting/intensive hot air

This type of heating uses bottom heating and the ring heating element. This type of heating is particularly suitable for deep-frozen foods. It is ideal for cooking pizzas, chips or strudels, without requiring preheating.

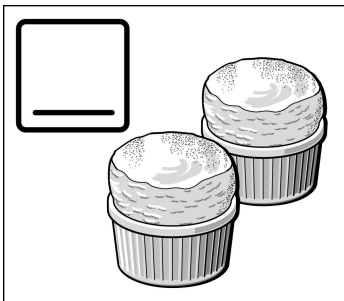

### Bottom heating

You can reheat or brown meals using bottom heating. It is also the most suitable type of heating for preserving food.

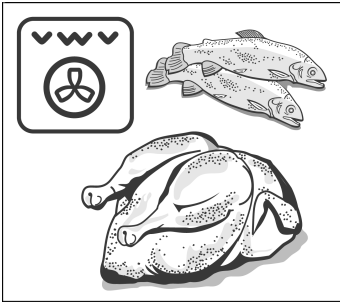

### Hot air grilling

This type of heating involves the grill element and the fan alternating between on and off. During the pause in heating, the fan circulates the heat generated by the grill around the food. This ensures that cuts of meat are crisped and brown on all sides.

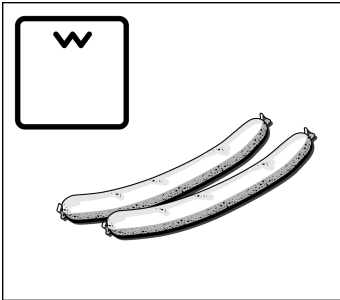

### Radiant grilling, small area

This involves only the middle section of the grill heating element being switched on. This type of heating is ideal for cooking small quantities. This saves energy. Place the pieces to be grilled in the centre of the wire grill.

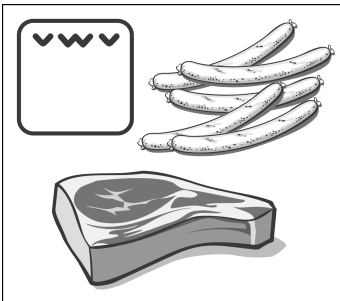

### Radiant grilling, large area

The entire area under the grill element becomes hot. This is ideal if you wish to cook several steaks, sausages, fish or slices of toast.

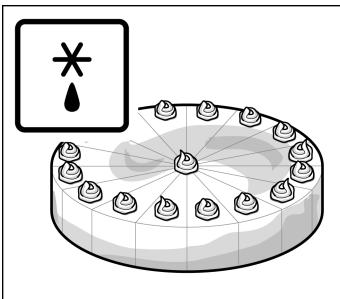

### Defrost

A fan in the rear wall of the oven circulates the air in the oven around the frozen food. Frozen pieces of meat, poultry, bread and cakes defrost evenly.

## Oven carriage and shelving accessories

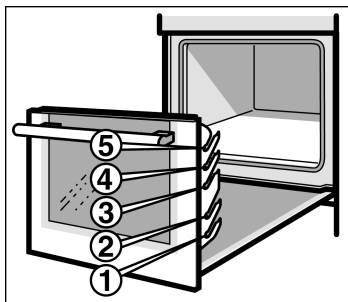

The shelf can be inserted at 5 different heights. The shelf must be inserted into the hooks on the left-hand and right-hand sides of the oven.

### Accessories

Accessories can be purchased from the technical assistance service or specialist retailers.

Your oven may include any of the following accessories:

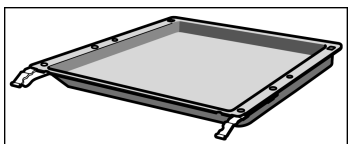

#### Enamel tray

For moist cakes, pastries, frozen food and large roasts. It can also be used to catch dripping fat when you are grilling directly on the wire rack.

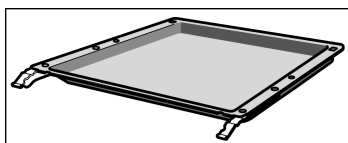

#### Aluminium tray

For cakes and biscuits.

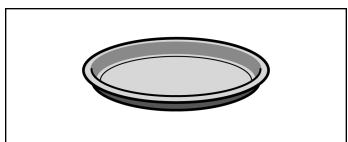

#### Pizza tray

Ideal for pizza, frozen foods and large round cakes, for example. You can use the pizza tray instead of the enamel tray. Place the tray on the wire grill.

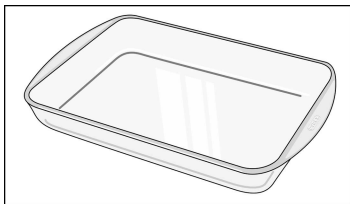

### **Glass casserole dish**

For all types of baked meats and fish.

Always use with the wire grille.

Place the glass casserole dish in the centre of the wire grille for a perfect roast.

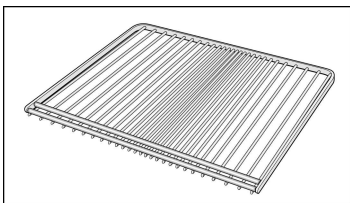

### **Wire rack**

for ovenware, cake tins, roasts, grilling and frozen meals.

---

## **Cooling fan**

The oven is fitted with a cooling fan. It switches itself on and off as necessary. The warm air escapes above the door.

---

# **Before using for the first time**



This section tells you everything you need to do before using the cooker for the first time.

Heat the oven and clean the accessories. Read the safety instructions in the “Important information” section.

Firstly, check to see if the  symbol and three zeros are flashing in the display.

**If the  symbol and three zeros are flashing in the display**

Set a time.

- 1.** Touch the  clock symbol.  
12:00 appears and the  clock symbol flashes in the display.
- 2.** Set the current time with the – or + symbol.
- 3.** Confirm with the OK symbol.  
The oven is ready for operation.

---

## Heating up the oven

### Method

Heat the empty oven with the door closed to remove the new oven smell.

1. Touch the ① main switch until the □ symbol appears in the display.
2. Set ▢ top/bottom heating. To do this, touch the ^ arrow until the ▢ symbol appears in the display.
3. Touch the + symbol until 240 °C appears in the temperature display.
4. Start the oven by touching the OK symbol.

Switch the oven off after 60 minutes using the ① main switch.

---

## Pre-cleaning the accessories

Please wash the accessories thoroughly with soapy water and a cleaning cloth before using them.

---

# Switching the oven on and off

---

## Main Sensor

The ① main sensor is used to switch the oven on and off.

### Switching on

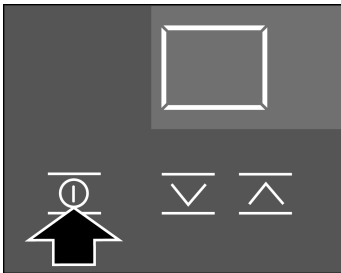

Touch the ① main sensor until the □ symbol appears in the display.

The main sensor switches off automatically if you do not set the oven within the next few minutes. The □ symbol goes out.

## Switching off

Touch the ① main sensor until the setting disappears.

The time, any timer period set and, if applicable, the residual heat indicator are independent of the main sensor.

---

# Setting the oven

## Switching off the oven manually

You have various options for setting the oven.

When your meal is ready, switch off the oven yourself.

## The oven switches off automatically

You can leave the kitchen for a long period.

## The oven switches on and off automatically

You can put your meal in the oven in the morning, for example, and set the oven so that your meal is ready at midday.



## Tables and tips

The correct settings for many dishes can be found in the Tables and tips section.

---

## Setting procedure

Example: Top/bottom heating , 190 °C

1. Switch on the ① main sensor. The  symbol lights up in the display.
2. Set the required type of heating with the  or  arrow.

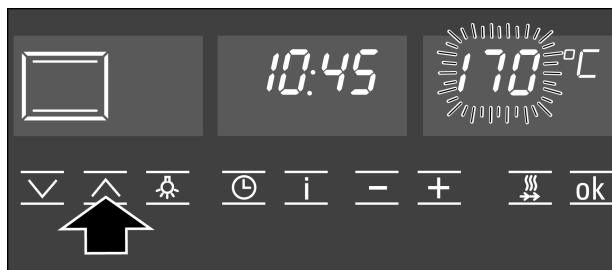

3. Set the desired temperature or grill setting with the – or + symbol.

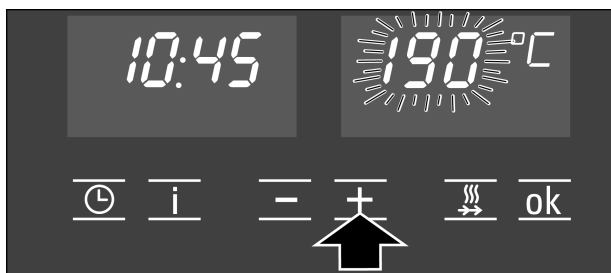

4. Start the oven by touching the OK symbol.

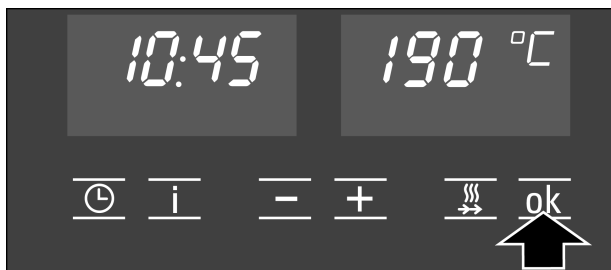

### Short beep

If you forget to start the oven, a short beep reminds you after a few seconds that you must touch the OK symbol to start.

### Switching off

Switch off the Ⓢ main sensor when the meal is ready.

### Changing the setting

You may change the type of heating, temperature or grill setting at any time. Confirm the change by touching the OK symbol.

### Preheating indicator

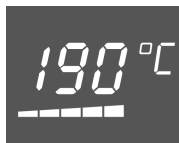

The preheating indicator provides a visual display of the oven temperature increase. It is best to insert the dish in the oven when all segments are lit. The preheating indicator does not appear during grilling and defrosting (20 °C).

During pre-heating it is possible to check:

- the oven's approximate temperature, touching the Info sensor **i**.
- the approximate time it takes the oven to reach the required temperature, touching the Info sensor **i** twice.

These times which appear in the display acknowledgement are only correct when the oven has been pre-heated without putting the food inside of it. This information is not shown when grilling.

## You want the oven to switch off automatically

5. Touch the ⌚ clock symbol repeatedly until the I→I duration symbol flashes in the display.

Set as described in points 1 to 4. Set the duration (cooking time) for your meal.

Example: for a duration of 45 minutes



6. Set the required duration with the - or + symbol.

+ plus  
default value = 30 min.  
- minus  
default value = 10 min.

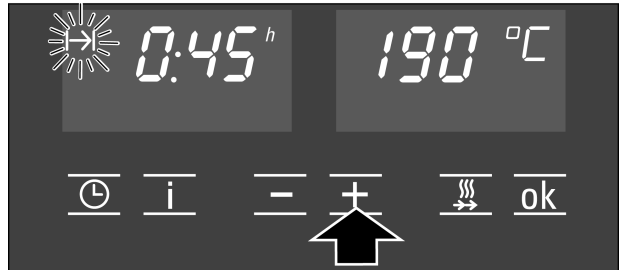

7. Start with the OK symbol or extend the end time, as described under the section entitled "You want the oven to switch on and off automatically".

The I→I duration symbol lights up in the display when you start the oven by touching the OK symbol.

## The duration has elapsed

A signal sounds. The oven switches off. 0:00 is shown in the clock display. You can cancel the signal in advance by touching the ⌚ clock symbol. The time appears again when you switch off the Ⓛ main switch.

## Clearing the duration

Touch the ⌚ clock symbol repeatedly until the I→I duration symbol flashes. Touch the – symbol until zero appears in the display. Touch the OK symbol. The oven is interrupted if it is in operation.

## Changing the setting

Touch the ⌚ clock symbol. Change the duration with the + or – symbol. Confirm with the OK symbol.

## Cancelling the setting

Switch off the Ⓜ main switch.

## Calling up settings

To call up the end time →I or time ⌚: touch the ⌚ clock symbol until the relevant symbol appears in the display. The value called up will then appear in the display for a few seconds.

---

## You want the oven to switch on and off automatically

Please remember that foods which spoil easily must not be allowed to remain in the oven for too long.

Example: the time is 10:45. The meal will take 45 minutes to cook and must be ready at 12:45 pm.

Set the oven as described in steps 1 to 6. The oven should not be switched on yet.

7. Touch the ⌚ clock symbol. The →I end time symbol flashes. In the display you will see the time when the meal will be ready.

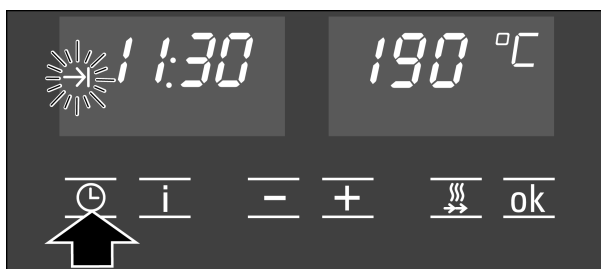

8. Extend the end time with the + symbol.

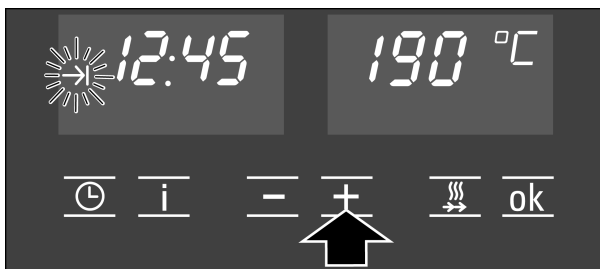

9. Confirm with the OK symbol.

The display will show the end time until the oven is switched on. The duration then counts down in the display.

### The duration has elapsed

A signal sounds. The oven switches off. 0:00 is shown in the clock display. The time appears again when you switch off the ⓐ main switch.

### Note

You can change the settings as long as a symbol in the display goes out. When the symbol lights up, the setting has been adopted. You can change the time before which a setting is adopted. See the Basic settings section for more details.

---

## Residual heat indicator

When you switch off the oven, the residual heat in the oven is indicated in the preheating indicator. When all segments are lit, the temperature in the oven is approximately 270 °C.

The preheating indicator goes out when the temperature has fallen to approximately 60 °C.

### Using the residual heat





You can keep food warm in the oven using the residual heat.

For meals with long cooking times, you may switch off the oven 5 to 10 minutes earlier. The residual heat will finish cooking the meal, thereby saving energy.

# Rapid heating

This allows you to preheat the oven particularly quickly.

You may use the rapid heating function with the following types of heating:

-  = Top/bottom heating
-  = Intensive heat
-  = Hot air
-  = Intensive hot air
-  = Bottom heating

## Method

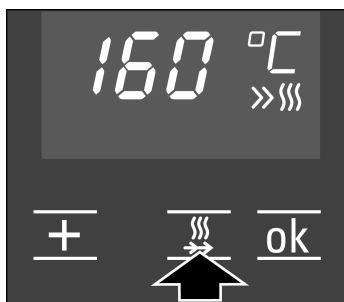

## Cancelling the rapid heating function

## Notes



Set the oven as required.

Touch the  rapid heating symbol.

The  symbol lights up in the temperature display.

The oven will heat up. The segments of the preheating indicator will light up.

When all segments of the preheating indicator are lit, a signal sounds and the  symbol goes out. Place the food in the oven.

Touch the  rapid heating symbol. The  symbol goes out in the temperature display.

The rapid heating function will not work if the temperature set is below 100 °C. If the temperature in the oven is only slightly below the temperature set, the rapid heating function is not necessary. It will not switch on.

The rapid heating function is interrupted if you change the type of heating.

During pre-heating it is possible to check:

- the oven's approximate temperature, touching the Info sensor **i**.
- the approximate time it takes the oven to reach the required temperature, touching the Info sensor **i** twice.

These times which appear in the display acknowledgement are only correct when the oven has been pre-heated without putting the food inside of it. This information is not shown when grilling.

---

## Automatic programme

The Automatic Programme makes it easy to prepare recipes.

The function consists of 14 programmes. Each of these corresponds to a different recipe (refer to the recipes in the accompanying recipe booklet).

All you have to do is choose the recipe which you wish to prepare, check the corresponding programme number (E.g.: **P02**), weigh the food and put it in the oven.

### Note

When preparing a recipe using this function, you need to bear in mind all the guidelines contained in the accompanying recipe booklet. To prepare other recipes which are not included in the accompanying recipe booklet, the automatic programme cannot be used.

---

## How long will the meal take to cook?

So that you know how long the meal will take to cook, set the oven as described in steps 1 to 6. The duration will appear in the display.

To interrupt the program: change the type of heating or switch off the ① main switch.

## Setting procedure

Select the appropriate program from the program table.

Example: program P2.

1. Switch on the  main sensor.
2. Select the automatic program with the  $\wedge$  or  $\vee$  arrow.  
P appears in the display.



3. Set the program number required with the + symbol.

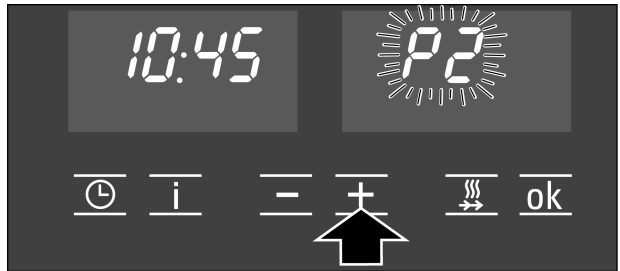

4. Confirm with the OK symbol.  
The default weight appears in the clock display.

5. Set the weight with the + or - symbol.



6. Confirm with the OK symbol.
7. Start the program with the OK symbol or extend the end time as subsequently described.

## The duration has elapsed

A signal sounds. The oven switches off.  
The time appears again when you switch off the  
Ⓛ main switch.

## Cancelling the program

Change the type of heating or switch off the Ⓛ main switch.

## You want the oven to switch on and off automatically

Only use fresh meat or fresh fish.

**Do not leave the food to stand in the oven for too long. Meat and fish will spoil easily when not in the refrigerator.**

Example: program P2. You want the meal to be ready by 12:15.

Set the oven as described in steps 1 to 6.

7. While the set program is flashing, touch the Ⓛ clock symbol until the → end time symbol flashes.

In the display you will see the time when the meal will be ready.

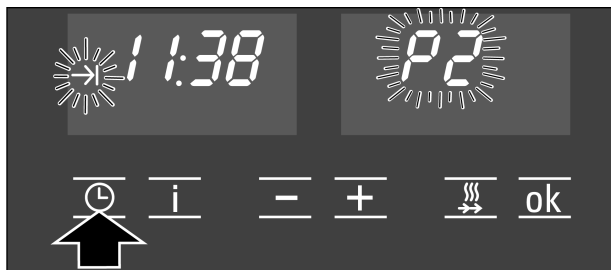

8. Extend the duration with the + symbol.



9. Confirm with the OK symbol.

The end time is shown in the display. The → end symbol lights up. The oven switches on at the appropriate time.

## The duration has elapsed

A signal sounds. The oven switches off. The time appears again when you switch off the Ⓜ main switch.

## Note

To call up the weight: Touch the i Info symbol. The weight appears for a few seconds in the display after the program has started.

---

# Time

When the oven is first connected or following a power cut, the Ⓜ symbol and three zeros flash in the display. Set a time.

---

## Setting procedure

Example: 13:00

1. Touch the Ⓜ clock symbol.  
12.00 appears in the display and the Ⓜ symbol flashes.

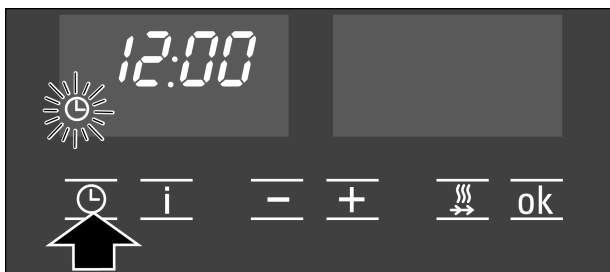

2. Adjust the time using the - or + symbol.

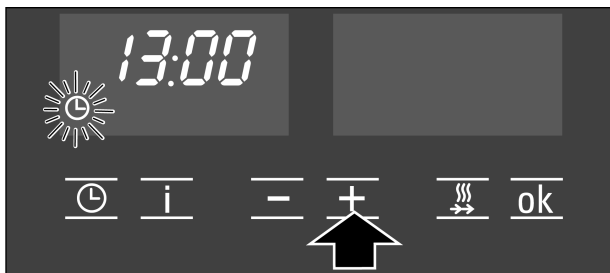

3. Confirm by pressing OK.  
The time appears. The Ⓜ symbol will go out.

## Changing the time e.g. from summer to winter time

The oven must be switched off.  
Touch the ⌚ clock symbol repeatedly until the ⌚ symbol flashes in the display. Adjust the time using the – or + symbol. Confirm by pressing OK.

## Hiding the time

You can adjust the setting for the time so that it is only shown when the oven is in operation.  
To do this, you must change the basic setting. See the Basic settings section.

---

# Timer

You can use the timer as a kitchen timer. It operates independently of the oven.  
The timer has a special signal.

---

## Setting procedure

Example: 20 minutes

1. Touch the ⌚ clock symbol repeatedly until the ⌚ timer symbol flashes.

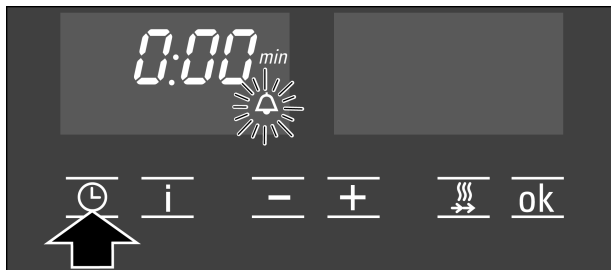

2. Set the timer period using the – or + symbol.

+ symbol default value = 10 min.

– symbol default value = 5 min.

3. Start the timer by touching the ok symbol.  
The time counts down visibly.



### The time has elapsed

A signal sounds. Touch the ⌚ clock symbol. The timer display will go out.

### Changing the timer period

Touch the ⌚ clock symbol. The ⏸ symbol will flash. Change the time by touching the – or + symbol. Start with the ok symbol.

### Cancelling the setting

The set timer continues to run even if the main switch is switched off.

Touch the ⌚ clock symbol. Reset the time to 0:00 using the – symbol. Confirm with the ok symbol. The time reappears in the display.

### The timer and duration count down simultaneously

Both symbols are lit in the display. The timer counts down visibly.

To call up the duration ⏸, end time →| or time ⌚: Touch the ⌚ clock symbol repeatedly until the ⏸ duration symbol, →| end time symbol or the ⌚ clock symbol appears.

The value called up will then appear in the display for a few seconds.

---

## Basic settings

Your oven has several basic settings. You can adapt these settings to your own preferences.

	Function	Option 1	Option 2	Option 3
In 1	Time in the clock display	The time is always displayed.	The time is only shown when the oven is in operation*	-
In 2	Signal duration after a set time has elapsed	Short	Medium	Long
In 3	Adoption time for adjustment increments	Approximately 20 seconds	Approximately 30 seconds	Approximately 40 seconds

	Function	Option 1	Option 2	Option 3
In 4	The cooling fan runs on until the oven reaches a certain temperature.	Short run-on time	Moderate run-on time	Long run-on time
In 5	Display brightness	Dim	Moderate	Bright
In 6	Audible signal when starting	Off	On	-

\* Exception: The time is shown when the residual heat is displayed.

## Changing the basic settings

There must be no program set.

Example: The time is only shown when the oven is in operation.

1. Touch the **i** Info symbol until **In 1** appears in the display.

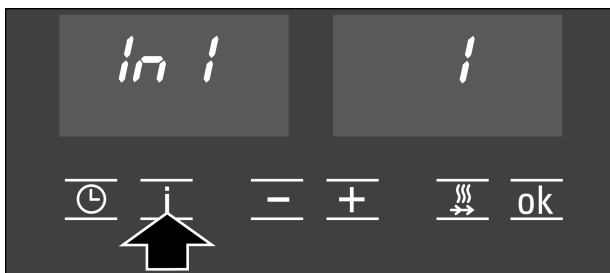

2. Adjust the basic setting using the + or – symbol.

All setting levels can be scrolled through using the **i** Info symbol and altered using the + or – symbol. Press OK to confirm that you have finished adjusting the settings.



### Correction

You may change your settings again at any time.

---

# Child-proof lock

The oven has a child-proof lock to prevent children switching it on accidentally or changing the setting.

## Locking the oven

Touch the OK symbol until the  key symbol lights up in the display.

The oven can no longer be set. A setting cannot be changed.

N.B. The current setting will be deleted if you touch the  main switch symbol. The childproof lock remains activated.

## Unlocking

Touch the OK symbol until the  key symbol in the display goes out.

## Note



The  symbol will flash in the display if you attempt to make settings on the oven when the childproof lock is activated. Release the lock.

---

# Automatic time limiter

If you have forgotten to switch off the oven, the automatic time limiter will be activated. Oven operation will be interrupted. The time when this happens depends on the selected temperature or grill setting.

A  appears in the display when the oven is no longer heating up. If the heating function is interrupted a signal sounds.

The heating function is interrupted until you switch off the  main switch. The  will disappear. Now you can reset the oven.

## Cancelling the automatic time limiter

If you enter a duration, the oven will then switch off at the required time.

The time limiter is cancelled.

---

# Care and cleaning

Do not use high-pressure cleaners or steam jets.

---

## Oven exterior

Wipe the oven with water and a little washing-up liquid. Dry it with a soft cloth.

Do not use corrosive or abrasive products. When this type of product comes into contact with an external part of the oven, clean it immediately.

Do not clean the oven's external parts with hard metal scouring pads as this may scratch the glass.

Slight differences in the colours on the appliance front are caused by the use of different materials, such as glass, plastic and metal.

## Appliances with stainless steel fronts

Always remove any flecks of limescale, grease, cornflour and egg white immediately. Corrosion can form under such flecks.

Use stainless steel care products. Follow the manufacturer's instructions. Try out the product on a small area first, before using on the whole surface.

---

## Oven

Never use coarse scouring pads or cleaning sponges. Oven cleaner may only be used on enamelled oven surfaces.

### For ease of cleaning

the oven door can be detached:

## Removing the oven carriage

Pull the oven carriage out to the stop, raise it slightly, then pull it out and store it carefully.

After cleaning, re-install the oven door, following the instructions in reverse order.

## Cleaning the catalytic surfaces of the oven

The rear wall, top and side walls of the oven are coated with self-cleaning enamel. The surfaces clean themselves while the oven is in operation. Large splashes may only disappear after the oven has been used several times.

Never use oven cleaner on self-cleaning surfaces.

If the self-cleaning surfaces of the oven are no longer cleaning themselves sufficiently, they can be regenerated using the cleaning function.

Should the enamel become slightly stained, this will not affect its self-cleaning properties.

### **Cleaning the oven floor**

Use hot soapy water or a vinegar solution.

It is best to use oven cleaner if the oven is very dirty. Only use oven cleaner in a cold oven.

Never use oven cleaner on the self-cleaning surfaces of the oven.

Note:

Enamel is baked on at very high temperatures. This can cause some slight colour variation. This is normal and does not affect the function. Do not use coarse scouring pads or strong cleaning agents to remove such discolorations.

The edges of thin trays cannot be completely enamelled. As a result, these edges can be rough. Anti-corrosion protection is guaranteed.

### **Cleaning the glass cover for the oven light**

It is best to clean the glass cover with washing-up liquid.

---

## **Cleaning function**

The cleaning function is a regeneration program. If the self-cleaning components of the oven are no longer cleaning themselves sufficiently, they can be regenerated using this function. They are then fully operational again.

Remove accessories and overware from the oven.

### **Caution**

Firstly, you must clean the oven surfaces which are not self-cleaning. Otherwise stains may appear that cannot be removed.

## Cleaning levels

You can set various cleaning levels, depending on how dirty the self-cleaning components are.

Cleaning levels:

3 = 1 hour 15 minutes

2 = 1 hour

1 = 45 minutes.

## Setting procedure

Switch on the  main switch.

1. Set clean with the  $\wedge$  up or  $\vee$  down arrow. The default level for cleaning level 2 appears in the temperature display.

You can change the cleaning level with the + or – symbol.

2. Start with the OK symbol. The cleaning time will appear in the display.

The oven switches off automatically after cleaning. The time reappears in the display.

## Extending the end time

The end time can be extended as long as the clean symbol is flashing.

Set the oven as described in step 1.

2. Touch the  clock button repeatedly until the  $\rightarrow$  end time symbol flashes.
3. Extend the duration with the + symbol.
4. Confirm with the OK symbol.

## When the oven has cooled

Wipe away salt residues from the self-cleaning components using a moist cloth.

---

## Seal

Clean the seal on the oven with washing-up liquid. Never use caustic or abrasive detergents.

---

## Accessories

Immediately after use, soak the accessories in washing-up liquid. Food residues can then be easily removed with a brush or sponge.

## Cleaning the glass panels

The glass panels on the oven door can be removed to assist in cleaning.

### Removal

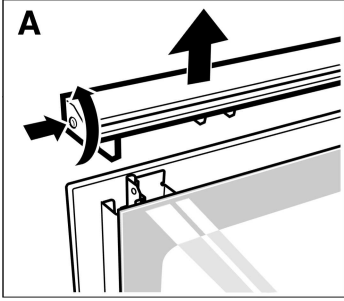

1. Slide out the oven carriage.
2. Unscrew the cover at the top of the oven door. To do this, undo the right and left-hand screws with a coin (Fig. A).

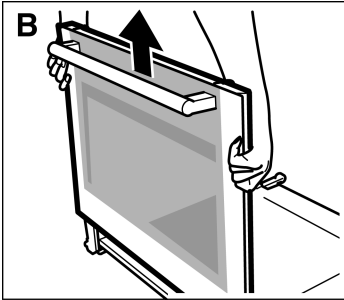

3. Hold the glass panels on the left and right and slide them upwards. (Fig. B)  
Lay it on a cloth with the handle underneath. The inner glass panel with the hanging hook remains on the oven carriage.

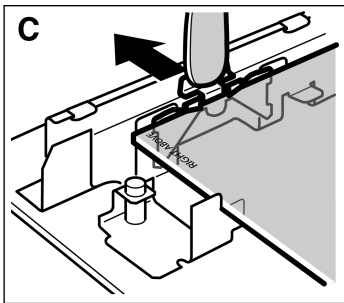

4. Push the front right and left retaining springs outwards one after the other. If the clamps prove difficult to push to the side, use a spoon to help you (Fig. C).  
Remove the upper panel.

Clean the glass panels with glass cleaner and a soft cloth.

## Installation

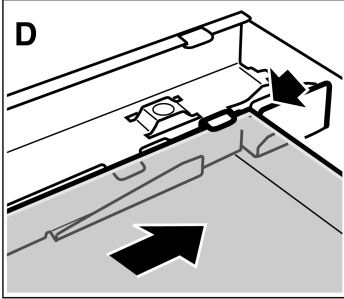

Make sure that the message “Right above” is upside down at the bottom left of both panels.

1. Slide in the glass panel towards the back at an angle. (Fig. D)
2. Push the right and left retaining springs outwards so that the panel lies on top.

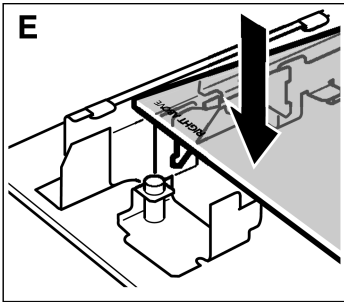



3. Push forward firmly on the panel until it clicks into place. Check whether the panel is securely seated. (Fig. E)
4. Insert the panels into the mounting on the oven carriage again.
5. Replace the cover and screw it back on. If the cover cannot be screwed on, check whether the panel is seated correctly in the mounting.
6. Close the oven carriage again.

**The oven must not be used again until the panels have been correctly installed.**

# Troubleshooting

Should a malfunction occur, it is often only due to a minor fault. Please read the following notes before calling the after-sales service.

Problem	Possible cause	Comments/remedy
The oven does not work.	Blown fuse.	Look in the fuse box to make sure that the fuse for the appliance is okay.
	Power cut	Check whether the kitchen light switches on.
	The oven is locked.	Touch OK symbol until the  key symbol goes out in the display.
The clock display flashes.	Power cut	Reset the time.
The oven does not heat up.	The oven door is not properly closed.	Close the oven door fully.
	The oven does not start heating.	Touch the OK symbol.
The oven does not heat up. A square appears in the temperature display.	The appliance is currently in demo mode.	Switch off the fuse in the fuse box. Wait for approximately 20 seconds. Switch on the fuse again. Within the next 2 minutes, press the rapid heating symbol for 6 seconds until the square in the display disappears.
A “5” appears in the clock display.	The oven was operated for a long period without the setting being changed. The automatic time limiter was activated.	Switch off the  main switch.
“E01” or “E04” appear in the display.	The temperature sensor has failed.	Contact the after-sales service.
“E02” appears in the display.	Faulty mains connection.	Switch off the fuse in the fuse box and connect the cooker properly.
“E03” appears in the display.	The electronic circuits have overheated.	The cooling fan is operating. “E03” will clear after cooling and the oven will continue heating.

<b>Problem</b>	<b>Possible cause</b>	<b>Comments/remedy</b>
"E05" appears in the display.	Communication error	Switch off the fuse in the fuse box, wait approximately 20 seconds and then switch it on again. Reset the time. If this error occurs frequently, call the after-sales service.
"E10" appears in the display.	Data error	Switch off the fuse in the fuse box, wait approximately 20 seconds and then switch it on again. Reset the time. If this error occurs frequently, call the after-sales service.
"E11" appears in the display.	A symbol was touched for too long.	Touch all control buttons individually. If the error message remains, please contact the after-sales service.
"E15" appears in the display.	The oven has become too hot.	Let the oven cool and then you will be able to operate it again. If this error occurs frequently, call the after-sales service.

**Repairs may only be carried out by fully trained after-sales service technicians.**

Incorrect repairs may result in serious injury to the user.

## Replacing the oven light

If the oven light fails, it must be replaced. Heat-resistant spare bulbs can be obtained from the after-sales service or specialist shops. Only use these bulbs.



Before replacing the light, check the oven is turned off to avoid any electric shock.

## Method

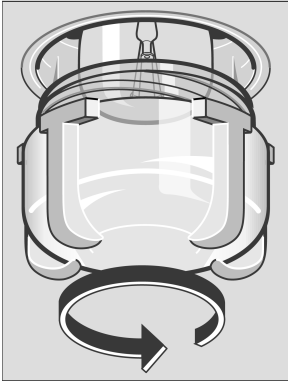

1. Disconnect the appliance from the mains.
2. Place a tea towel in the cold oven to prevent damage.
3. Unscrew the glass cover by turning it anti-clockwise.
4. Replace the oven light with one of the same type.
5. Screw the glass cover back on.
6. Remove the tea towel and connect the appliance from the mains.

## Method

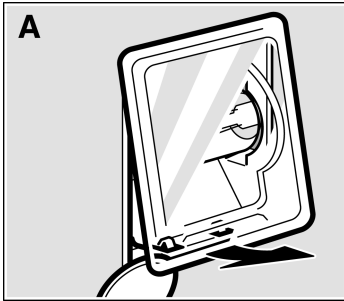

1. Switch off the oven fuse in the fuse box.
2. Place a tea towel in the cold oven to prevent damage.
3. Remove the glass cover. To do this, open the glass cover at the bottom with your hand. Figure A.  
If the glass cover is difficult to remove, use a spoon to help you.

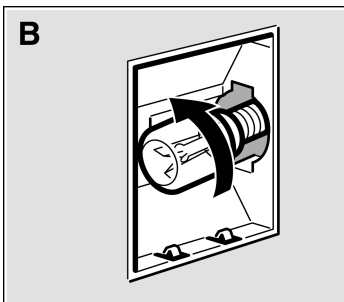

4. Unscrew the bulb and replace it with one of the same type. Figure B.

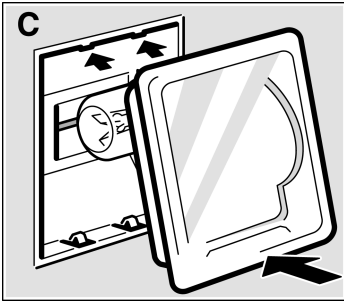

5. Fit the glass cover back on. Ensure that the curvature in the glass is on the right. Insert the glass cover at the top and press it firmly on at the bottom. Figure C. The glass cover will now click into place.
6. Remove the tea towel and switch the fuse back on.

### Replacing the glass cover

The glass cover on the oven light must be replaced if it is damaged. Replacement glass covers may be obtained from the after-sales service. To this end, please specify the E number and FD number of your appliance.

---

## After-sales service

Our after-sales service is there for you if your oven needs repairing. You will find the address and telephone number of your nearest after-sales service centre in the phone book. The after-sales service centres listed will also be happy to advise you of a service point in your local area.

### E number and FD number

Please quote the E number (product number) and the FD number (production number) of your appliance when contacting the after-sales service. The rating plate containing these numbers is found on the right, on the side of the oven door. You can make a note of these numbers in the space below to save time in the event of your appliance malfunctioning.

E no.	FD no.
-------	--------

After-sales service ☎
-----------------------

---

# Packaging and old appliances

**Disposing in an environmentally-responsible manner**



Unpack the appliance and dispose of the packaging in an environmentally-responsible manner.

This appliance is marked according to the European directive 2002/96/EC on Waste Electrical and Electronic Equipment (WEEE).

This guideline is the frame of a European-wide validity of return and recycling on Waste Electrical and Electronic Equipment.

---

# Tables and tips

This table contains a selection of dishes and the optimum settings at which to cook them. You can find out which type of heating and temperature is best for your dish, which accessories to use, and at which oven level the dish should be inserted. You will find a variety of tips about ovenware and preparation, and a small troubleshooting section in case anything should go wrong.

---

## Cakes and pastries

### Baking tins

It is best to use dark baking tins. You should use hot air when using thin baking tins, or glass containers. This means, however, that the baking time is increased and the cake does not brown so evenly.

Always place the cake tin on the wire grill.

If you are cooking using three tins at the same time, place the cakes diagonally on the accessories.









## Tables

The values in the table apply to dishes placed in a cold oven. This saves energy. Shorten the baking times indicated by 5 to 10 minutes if you have preheated the oven.

The tables show which type of heating is best for different cakes and bakes.









The temperature and cooking time you select depends on the quantity and type of pastry. This is why “ranges” are given in the tables. You should try to use a lower temperature setting to start with, since this allows more even browning. If necessary, use a higher temperature setting the next time.







More information can be found in the “Baking tips” section which follows the tables.

Cakes in tins	Tin on the wire grill	Level	Type of heating	Temperature in °C	Baking time in minutes
Sponge cake, simple	Bowl/Vienna ring/ cake tin	2		160-180	50-60
	3 cake tins*	2+3		140-160	70-100
Sponge cake, delicate (e.g. pound cake)	Bowl/Vienna ring/ cake tin	2		140-160	60-70
	* cake tins	2+3		140-160	70-100
Short pastry base with edge	Springform cake tin	1		170-190	25-35
Cake base made from sponge mixture	Fruit cake base	2		160-180	20-30
Fruit cake or cheesecake, short pastry**	Non-stick springform cake tin	2		170-190	70-90
Fruit cake, fine sponge mixture	Springform cake tin/bowl mould	2		160-180	50-60
Savoury cakes** (e.g. quiche/onion tart)	Springform cake tin	1		200-220	40-50

\* Please position the tins correctly.

\*\* Allow cakes to cool in the oven for approximately 20 minutes.

Cakes on the tray		Level	Type of heating	Temperature in °C	Baking time in minutes
Sponge or yeast pastry with dry topping	Tray	2		170-190	20-30
	2 trays	2+3		150-170	
Sponge or yeast pastry with fruit topping	Tray	2		170-190	40-50
	2 trays	2+3		140-160	
Stollen made with 500 g flour	Tray	3		160-180	60-70
Stollen made with 1 kg flour	Tray	3		150-170	90-100
Strudel, sweet	Enamel tray	2		190-210	55-65
Pizza		2		190-210	25-35
		2+3		170-190	40-50

Small baked products		Level	Type of heating	Temperature in °C	Baking time in minutes
Biscuits	Tray	3		150-170	10-20
	2 trays	2+3		130-150	25-35
Meringue	Tray	3		80-100	100-150
Macaroons	Tray	3		110-130	30-40
	2 trays	2+3		100-120	35-45
Puff pastry	Tray	3		180-200	20-30
	2 trays	2+3		180-200	30-40

## Baking tips

**You wish to cook to your own recipe.**

Refer to the instructions in the tables for similar types of food.

**How to check that a sponge cake is cooked properly.**

Approximately 10 minutes before the end of the baking time given in the recipe, pierce the tallest point of the cake with a cocktail stick. The cake is done if the cocktail stick comes out clean.

**The cake collapses.**

Next time, use less liquid or decrease the oven temperature by 10 degrees. Observe the cooking times in the recipe.

**The cake has risen in the centre but is lower at the edges.**

Do not grease the sides of the springform cake tin. As soon as the cake is done, carefully loosen the cake around the edges using a knife.

**The cake is too dark at the top.**

Insert it at a lower level in the oven, select a lower temperature and cook the cake a little while longer.

---

**The cake is too dry.**

Use a toothpick to make small holes in the finished cake. Then drizzle fruit juice or alcohol over the top. Next time you should decrease the temperature by around 10 degrees and reduce the baking times.

---

**The bread or cake (e.g. cheesecake) looks fine, but is soggy on the inside (soft, with watery areas).**

Next time you should add a little less liquid and cook for a little longer at a lower temperature. Cakes with fruit topping: Precook the base first of all. Sprinkle with almonds or breadcrumbs and then place the topping over this. Please observe the recipe and the baking times.

---

**The pastry is unevenly browned.**

Select a slightly lower temperature to ensure that the pastry is baked more evenly. Delicate pastry should be baked on one level using top/bottom heating . Baking paper that protrudes over the food can affect the air circulation. For this reason, always cut the baking paper to fit the baking tray.

---

**You were baking on several levels. The food on the top baking tray is darker than that on the bottom baking tray.**

Always use hot air when baking on several levels. Baking trays that are placed in the oven at the same time will not necessarily be ready at the same time.

---

**Condensation is formed when baking cakes containing fresh fruit.**

Most escapes through the steam outlet, some may condense on the cool control panel front or the surrounding cabinets where it will drip off. This will be dependent on the physical conditions.

---

---

## **Meat, poultry, fish**

### **Ovenware**

You may use any heat-resistant dishes.

Always place the dishes in the centre of the wire grill.

Hot glass dishes should be placed on a dry kitchen towel after being removed from the oven. The glass could crack if placed on a cold or wet surface.

### **Advice on roasting**

The roasting result depends on the type and quality of meat.

Add 2 to 3 soup spoons of liquid to lean meat, and 8 to 10 soup spoons of liquid to pot roasts, depending on the size.

Meat should be turned half way through the cooking time.

When the roast is ready, switch off the oven and leave the roast to stand for 10 minutes with the oven door closed. This allows the meat juices to distribute more favourably.

## Advice on grilling

Always close the oven door when grilling.

If possible, use pieces of meat which are of the same thickness. They should be at least 2 to 3 cm thick. Such pieces will be browned evenly and stay juicy and soft in the middle. Only salt the steaks after they have been grilled.

Place the pieces of meat directly onto the wire grill. If you are grilling just one piece of meat, it will turn out best if you place it in the centre of the wire grill.

You should also insert the enamel tray at level 1. The meat juices are collected here and the oven is kept clean.







Turn the pieces of meat after two thirds of the cooking time indicated.

The grill element automatically switches itself off and back on again. This is normal. The number of times this happens depends on the grill setting you have selected.

## Meat

The table applies to insertion into a cold oven. The time specifications are provided as guidelines only and depend on the type and quality of the meat.

Meat	Weight	Ovenware	Level	Type of heating	Temperature in °C, grill	Cooking time in minutes
Beef pot roast (e.g. ribs)	1 kg	Covered	2		200-220	100
	1.5 kg		2		190-210	120
	2 kg		2		180-200	140
Sirloin of beef	1 kg	Uncovered	2		200-220	80
	1.5 kg		2		190-210	90
	2 kg		2		180-190	100
Sirloin, medium-rare*	1 kg	Uncovered	1		230-240	60
Steaks, well done		Wire grill*	5		Setting 3	20
Steaks, medium rare		Wire grill*	5		Setting 3	15
Pork without rind (e.g. neck)	1 kg	Uncovered	1		190-210	100
	1.5 kg		1		180-200	140
	2 kg		1		170-190	160
Pork with rind** (e. g. shoulder, leg)	1 kg	Uncovered	1		190-210	130
	1.5 kg		1		180-200	160
	2 kg		1		170-190	190

Meat	Weight	Ovenware	Level	Type of heating	Temperature in °C, grill	Cooking time in minutes
Smoked pork on the bone	1 kg	Covered	2		210-230	70
Meat loaf	750 g	Uncovered	1		180-200	70
Sausage	approx. 750 g	Wire grill***	4		Setting 3	12
Roast veal	1 kg	Uncovered	2		180-200	110
	2 kg		2		160-180	130
Leg of lamb without bone	1.5 kg	Uncovered	1		160-180	120

\* Turn roast beef after half the cooking time. After cooking, wrap the sirloin in aluminium foil and leave in the oven to stand for 10 minutes.

\*\* Make cuts in the pork rind and place the pork in the dish if the pork is to be turned, first place the pork with the rind side down.

\*\*\* Insert the enamel tray at level 1.

## Poultry

The table applies to dishes placed in a cold oven.







The weights indicated in the table refer to oven-ready poultry (without stuffing).

If you are grilling directly on the wire rack, you should also insert the enamel tray at level 1.

Pierce the skin of duck or goose under the wings to enable the fat to run off.





Turn whole poultry after two thirds of the grilling time.

Poultry will turn out particularly crispy and brown if you baste it towards the end of the roasting time with butter, salted water or orange juice.

Poultry	Weight	Ovenware	Level	Type of heating	Temperature in °C	Cooking time in minutes
Chicken halves, 1 to 4	400 g each	Wire rack	2		210-230	40-50
Chicken pieces	250 g each	Wire rack	2		210-230	30-40
Whole chickens, 1 to 4	1 kg each	Wire rack	2		200-220	50-80
Duck	1.7 kg	Wire rack	2		180-200	90-100
Goose	3 kg	Wire rack	2		160-180	110-130
Young turkey	3 kg	Wire rack	2		180-200	80-100
2 turkey drumsticks	800 g each	Wire rack	2		180-200	90-110

## Fish

The table applies to dishes placed in a cold oven.

Fish	Weight	Ovenware	Level	Type of heating	Temperature in °C, grill setting	Duration, minutes
Fish, grilled	300 g each	Wire rack*	2		2	20-25
	1 kg		2		200-220	40-50
	1.5 kg		2		190-210	50-60
Sliced fish (e.g. fish steaks)	300 g each	Wire rack*	3		2	20-25

\* Insert the enamel tray at level 1.

## Tips for roasting and grilling

**The table does not contain specifications for the weight of the roast.**

Select the next lowest weight from the instructions and extend the time.

**How can you tell when the roast is ready.**

Use a meat thermometer (available from specialist stores) or implement a "spoon test". Press a spoon onto the roast. If it feels firm, it is ready. If it can be pressed in, it needs to be cooked for a little longer.

**The roast is too dark and the crackling is partly burnt.**

Check the insertion level and temperature.

**The roast looks good, but the sauce is burnt.**

Next time, use a smaller roasting dish and add more liquid.

**The roast looks good, but the sauce is too light and watery.**









Next time, use a larger roasting dish and add less liquid.

**Steam rises from the roast when the stock is added.**

Most escapes through the steam outlet, some may condense on the cool control panel front or the surrounding cabinets where it will drip off. This will be dependent on the physical conditions.

## Bakes, gratins, toast

The table applies to dishes placed in a cold oven.

Meal		Ovenware	Level	Type of heating	Temperature in °C, grill setting	Duration, minutes
Sweet bakes (e.g. quark and fruit bake)		Ovenproof dish	2		170-190	50-60
Savoury bakes made from cooked ingredients (e.g. pasta bake)		Ovenproof dish or enamelled pan	2		210-230	30-40
			2		210-230	20-30
Savoury bakes made from raw ingredients* (e.g. potato gratin)		Ovenproof dish or enamelled pan	2		160-180	50-60
			2		160-180	50-60
Toast	4 slices	Wire rack	5		3	6-7
	12 slices		5		3	4-5
Toast gratin	4 slices	Wire rack**	4		3	7-10
	12 slices		4		3	5-8









\* The bake must be no taller than 2 cm.







\*\* Insert the enamelled pan at level 1.

## Frozen foods

Please observe the instructions on the packaging.

The values in the table apply to dishes placed in a cold oven.

Meal	Use for	Level	Type of heating	Temperature in °C	Cooking time in minutes
Pizza*	Pizza with a thin base	2		200-220	15-25
	Pizza with a thick base	2		180-200	20-30
	Pizza baguette	2		180-200	20-30
	Mini pizza	3		190-210	10-20
Potato products*	Chips	2		200-220	20-30
	Duchess potatoes	2		200-220	20-30
	Fried potatoes	2		200-220	20-30
	Filled potato skins	2		200-220	15-25

Meal	Use for	Level	Type of heating	Temperature in °C	Cooking time in minutes
Baked goods*	Rolls	3		190-210	10-20
	Croissants	2		200-220	5-15
	Pretzels	3		200-220	10-20
Fried foods*	Fish fingers	2		200-220	5-15
	Chicken nuggets	2		200-220	10-25
	Vegetable burgers	2		200-220	15-30
Strudel*	Apple strudel	3		190-210	30-40

\* Line the enamel pan with greaseproof paper. Please ensure that the greaseproof paper is suitable for use at these temperatures.



## Slow cooking

Slow cooking is the ideal cooking method for all tender pieces of meat which are to be cooked rare or very rare. The meat remains very juicy and turns out as soft as butter. Advantages: The benefit of this cooking method is that it allows lots of scope for menu planning because slow-cooked meat is easy to keep warm.

### Suitable dishes

Use a shallow dish, e.g. a porcelain serving dish.

### Method

1. Touch the  main switch.
2. Select top/bottom heating  using the  $\wedge$  up arrow.
3. Touch the – symbol until 90 °C appears.
4. Touch the OK symbol to start the oven.
5. Preheat the oven and also warm up a serving dish on the wire rack at shelf position 2.
6. Heat a little fat in a pan to a high temperature. Sear the meat over a high heat and then place directly on the warmed plate.
7. Put the dish with the meat back into the oven and complete the cooking. For most pieces of meat a cooking completion temperature of 90 °C is ideal.

## Notes on slow cooking

Only use perfectly fresh meat for this.

Sear the meat at a very high temperature and for a sufficient amount of time.

When completing the cooking in the oven, do not cover the meat.

The meat should not be turned even if it is a large joint.

The meat can be cut immediately after slow cooking. It is not necessary to leave the meat to stand.

This particular cooking method always leaves the inside of the meat medium rare. However, this does not mean that it is raw or not cooked properly.

## Table

All tender joints of beef, pork, veal and lamb are suitable for slow cooking. The length of time for searing and completing are worked out according to the size of the piece of meat.

The times for searing refer to the meat being inserted in hot fat.

<b>Meal</b>	<b>Searing on the hotplate (time in minutes)</b>	<b>Completing in the oven (time in minutes)</b>
<b>Small pieces of meat</b>		
Cubes or strips	1-2 all over	20-30
Small cutlets, steaks or médaillons	1-2 per side	35-50
<b>Medium-sized pieces of meat</b>		
Whole fillet (400 - 800 g)	4-5 all over	75-120
Saddle of lamb (approx. 450 g)	2-3 per side	50-60
Double cutlet	7-9 all over	100-120
<b>Large pieces of meat</b>		
Whole fillet (over 900 g)	6-8 all over	120-150
Roast (600 g - 1 kg)	8-10 all over	120-150
Roast (1.1 - 2 kg)	8-10 all over	180-270

---

## Tips on slow cooking

**Meat that has been cooked using slow cooking is not as hot as meat that has been cooked conventionally.**

Warm the plates and serve the sauce at a high temperature.

**If you want to keep slow-cooked meat warm.**



Turn the temperature down to 70 °C after slow-cooking. Small pieces of meat can be kept warm for up to 45 minutes, and large pieces for up to two hours.

---

---

## Special meals

You can set temperatures of up to 270 °C with this cooker. This makes it particularly good for cooking crispy pizzas or savoury flans. Just try it.

	Ovenware	Level	Type of heating	Temperature in °C	Cooking time
Preheat	Pizza dish or	1		300	7-12 Minutes
Pizza	Enamel baking	3		300	7-12 Minutes
Savoury flans (yeast dough with thin topping)	tray				
Meat in pastry (preheat to 280 - 300 °C)	Enamel baking tray	2		170-190	110-120 Minutes
750 g to 1 kg of meat and the	same amount of bread dough.				
Fish, whole, 2 kg (e.g. fresh salmon)	Rack*	2		280-300 95	10 Minutes 50-60 Minutes

Place the prepared fish on the wire grill. Preheat the oven to 270 °C, sear the fish for 10 minutes at this temperature, and then lower the temperature to 95 °C.



---

## Defrosting

Remove the food from its packaging and place it in a suitable dish on the wire grill.

Please observe the instructions on the packaging.

The defrosting times depend on the type and amount of food.

Meal	Accessories	Level	Type of heating	Temperature in °C
<b>Delicate frozen foods</b> e.g. cream gateaux, cream cakes, cakes with chocolate or icing, fruit etc.	Wire rack	2		20 °C
<b>Other frozen foods*</b> Chicken, sausage and meat, bread, bread rolls and other pastries	Wire rack	2		50 °C

\* Cover frozen food with microwave foil. Place poultry onto the plate with the breast side down.





In the 30 to 60 °C range, the oven light remains switched off. This gives best control.

## Drying

Only use perfectly fresh fruit and vegetables, and wash them thoroughly.

Allow the food to drain well and dry it yourself.

Line the enamel baking tray and wire rack with baking paper or greaseproof paper.

Meal	Level	Type of heating	Temperature in °C	Cooking time in hours
600 g apple rings	2 + 3		80	Approx. 5
800 g sliced pears	2 + 3		80	Approx. 8
1.5 kg prunes or plums	2 + 3		80	Approx. 8 - 10
200 g fresh herbs, washed	2 + 3		80	Approx. 1½

### Note

Very moist fruit or vegetables should be turned several times. Once dried, remove the food from the paper immediately.

---

# Preserving

## Preparation

The jars and rubber sealing rings must be clean and intact. Use jars of the same size if possible. The instructions in the table refer to round 1-litre jars. Caution Do not use larger or taller jars. The lid could crack.



Only use perfectly fresh fruit and vegetables. Wash them thoroughly.

Pour the fruit or vegetables into the jars. Wipe clean the tops of the jars again if necessary. They must be clean. Place a wet rubber sealing ring and lid on each jar and lock the jars using clamps.

Do not place more than six jars in the oven.

The times specified in the tables are guidelines only. They can be influenced by the room temperature, the number of jars and the amount and temperature of the jar contents. Before you change settings or switch off the appliance, make sure that the contents of the jars are actually bubbling.

## Setting procedure

1. Place the Enamel baking tray on level 2. Place the jars inside the pan so that they do not come into contact with each other.
2. Pour ½ litre of hot water (approx. 80 °C) into the Enamel baking tray.
3. Close the oven door.
4. Touch the  main switch.
5. Set bottom heating  using the arrow .
6. Touch the + symbol until 170 - 180 °C appears in the display.
7. Start the oven by touching the OK symbol.

## Preserving fruit

As soon as the contents of the jars begins to simmer, that is when small bubbles appear at short intervals - after about 40 to 50 minutes - turn off the  main switch.

The jars should be removed from the oven after being reheated for 25 to 35 minutes. If the food is left to cool in the oven for longer, bacteria might form, accelerating spoilage of the preserved fruit.

<b>Fruit in 1-litre jars</b>	<b>After bubbling</b>	<b>Reheating</b>
Apples, red/blackcurrants, strawberries	Turn off	Approx. 25 minutes
Cherries, apricots, peaches, gooseberries	Turn off	Approx. 30 minutes
Apple purée, pears, plums	Turn off	Approx. 35 minutes

### **Preserving vegetables**

As soon as the contents of the jars begin to simmer, set the temperature back to approximately 120 to 140 °C. Start by touching the ok symbol again. The table shows when you can switch off the oven: Allow the vegetables to stand in the oven for a further 30-35 minutes.

<b>Vegetables with cold stock in 1-litre jars</b>	<b>After bubbling 120-140 °C</b>	<b>Reheating</b>
Cucumbers	-	Approx. 35 minutes
Beetroot	Approx. 35 minutes	Approx. 30 minutes
Brussel sprouts	Approx. 45 minutes	Approx. 30 minutes
Beans, kohlrabi, red cabbage	Approx. 60 minutes	Approx. 30 minutes
Peas	Approx. 70 minutes	Approx. 30 minutes

### **Remove the jars**

Never place the hot jars on a cold or wet surface as this could cause the glass to crack.

---

## Energy saving tips

Only preheat the oven if it specifies in the recipe or in the table in the instruction manual that you should do so.

Use non-stick, black painted or enamelled tins. They absorb the heat especially well.

If you have several cakes to bake it is best to bake them one after the other. The oven is still warm. This shortens the baking time for the second cake. You can also put two baking tins in one after the other.

For long cooking times, the oven can be switched off 10 minutes before the end of the cooking time and the remaining heat can be used to finish the cooking.

---

## Acrylamide in food

Experts are currently discussing how dangerous acrylamide in food can be. We have compiled this information sheet for you on the basis of current research.

### Where does acrylamide come from?

Acrylamide in food does not come from external contamination. It is formed in the food itself during preparation - provided that the food contains carbohydrate and protein. Exactly how this happens has not yet been completely explained. However, it appears that the acrylamide content is strongly influenced by:

- high temperatures
- a low water content in food
- intensive browning of the food.

### What sort of foods are affected?

Acrylamide forms mostly in grain and potato products that are prepared at high temperatures, e.g.:

- crisps, chips,
- toast, rolls, bread,
- baked goods made from shortcrust pastry (speciality biscuits and cakes).

---

## What can you do?

You can avoid high levels of acrylamide when baking, frying and grilling.

The following recommendations were published by AID<sup>1</sup> and BMVEL<sup>2</sup> to help you minimise acrylamide levels:

### In general

Keep cooking times as short as possible.

“Brown rather than burn” - cook food only until it is golden brown.

The larger and thicker the food is, the less acrylamide it contains.

### Baking

Set the temperature to a maximum of 180 °C when using the hot air setting.

Cookies: Set the temperature to a maximum of 170 °C when using the hot air setting. The presence of egg or egg yolk in a recipe reduces the formation of acrylamide.

Spread oven chips evenly over the baking sheet in one layer where possible. To prevent the food from drying out quickly, place at least 400 g on each baking sheet.

<sup>1</sup> AID “Acrylamide” information leaflet, published by AID (German Evaluation and Information Service for Nutrition, Agriculture and Forestry) and BMVEL (German Federal Ministry for Consumer Protection, Food and Agriculture), as at 12/02, Internet: <http://www.aid.de>







<sup>2</sup> BMVEL press release 365, as at 4.12.2002, Internet:<http://www.verbraucherministerium.de>

# Test dishes

In accordance with DIN 44547 and EN 60350

## Baking

The values in the table apply to dishes placed in a cold oven.

Meal	Accessories and notes	Level	Type of heating	Temperature in °C	Baking time in minutes
Small cakes x 20	Tray	3		170-190	20-30
Small cakes, 20 per baking tray (preheat)	2 trays	2+3		140-160	25-35
Yeast cakes on a baking tray	Tray	3		170-190	40-50
	2 trays	2+3		140-160	50-60
German apple pie	2 wire racks* + 2 tinplate springform cake tins Ø 20 cm*	2+3		180-200	70-80
	Enamelled pan + 2 tinplate springform cake tins Ø 20 cm*	1		190-210	70-80



\* If you are using both levels of the oven, place the aluminium tray on the lower level.

\*\* Place the cakes diagonally on the accessories.

Baking trays may be obtained as optional accessories from specialist shops.

## Grilling

The values in the table apply to dishes placed in a cold oven.

Meal	Accessories	Level	Type of heating	Grill setting	Cooking time in minutes
Toast (preheat for 10 mins.)	Wire rack	5		Setting 3	1-2
Beefburgers, x 12*	Wire rack	4		Setting 3	25-30

\* Turn after  $\frac{2}{3}$  of the time has elapsed. Always insert the enamelled pan at level 1.

DE <http://www.bosch-hausgeraete.de>  
GB <http://www.boschappliances.co.uk>  
FR <http://www.bosch-electromenager.com>  
NL <http://www.bosch-huishoudelijke-apparaten.nl>  
FI <http://www.bosch-kodinkoneet.com>  
DK <http://www.bosch-hvidevarer.com>  
ES <http://www.bosch-ed.com>  
PT <http://www.bosch.pt>  
BE <http://www.electro.bosch.be>  
AU <http://www.bosch.com.au>  
AT <http://www.bosch-hausgeraete.at>  
BR <http://www.boschelectrodomesticos.com.br>  
GR <http://www.bosch-home.gr>  
US <http://www.boschappliances.com>

9000144520 (1W069L) 00 8703