

Instruction manual

---



PKN 64.., PKB 64..  
PKL 64.., PKF 64..  
PKE 64..

9000068878

**PKN 64..**

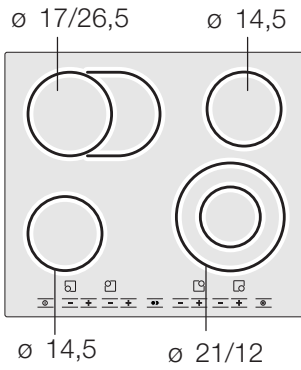

**PKB 64..**

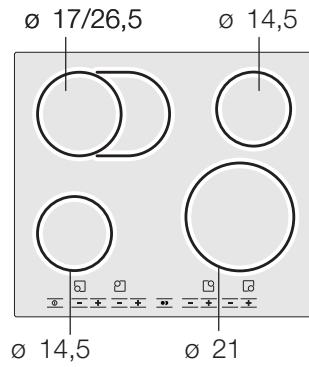

**PKL 64..**

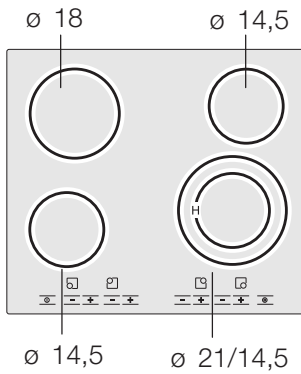

**PKF 64..**

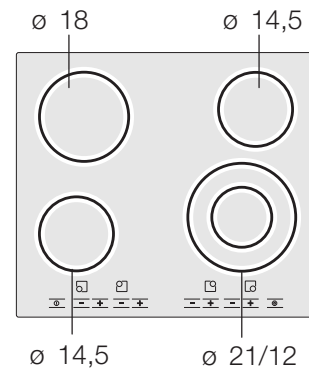

**PKE 64..**

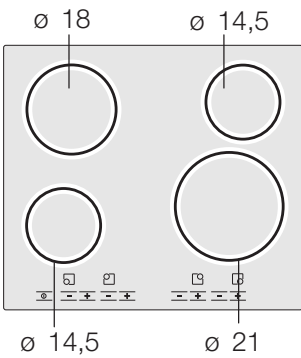

$\varnothing = \text{cm}$

# Table of contents

<b>Important information</b> .....	<b>5</b>
Before installation .....	5
Safety precautions .....	5
Reasons for damage .....	6
<b>Getting to know the appliance</b> .....	<b>8</b>
The control panel .....	8
The hotplates .....	9
Residual heat indicator .....	10
<b>Main switch with childproof lock</b> .....	<b>10</b>
Main switch .....	10
Childproof lock .....	11
<b>Cooking</b> .....	<b>12</b>
Settings .....	12
Table .....	13
Tips on saving energy .....	15
<b>Cooking with the electronic boil start control</b> ..	<b>15</b>
Setting procedure .....	16
Tables .....	16
Tips on electronic boil start control .....	17
<b>Automatic time limiter</b> .....	<b>18</b>

## Table of contents

<b>Care and cleaning</b> .....	<b>18</b>
Care .....	18
Cleaning glass ceramic .....	18
Cleaning the hob surround .....	19
<b>Troubleshooting</b> .....	<b>20</b>
Notes: .....	21
<b>Packaging and old appliances</b> .....	<b>22</b>
<b>After-sales service</b> .....	<b>22</b>
<b>Acrylamide in food</b> .....	<b>23</b>
What can you do? .....	23

---

# Important information

Read this instruction manual carefully. Only then will you be able to operate your hob safely and correctly.

Keep the instruction and installation manual and the appliance pass in good condition. Please pass on these documents to the new owner if you sell the appliance.

---

## Before installation

### Transport damage

Check the hob after unpacking it. Do not connect the appliance if it has been damaged in transport.

### Electrical connection

The hob may only be connected by a licensed specialist. Damage due to the appliance being connected incorrectly will invalidate the guarantee.

---

## Safety precautions

### Overheated oil and fat

This appliance is intended only for domestic use. Only use the hob for food preparation.

Overheated oil or fat can ignite very quickly.

Risk of fire!

Never leave heating oil or fat unsupervised.

Should the oil ignite, do not try to put it out by pouring water on it.

Cover the pan with a lid or plate immediately.

Switch off the hotplate.

Leave the ovenware on the hotplate to cool down.

### Hot hotplates

Do not touch hot hotplates. There is a risk of burning. Children must be kept at a safe distance from the appliance. The residual heat indicator warns you that the hotplates are hot.

Never place combustible items on the hob.

Risk of fire!

You must not keep any combustible items or aerosol cans in a drawer located under the hob. Risk of fire!

### **Wet saucepan bases and hotplates**

The service cables from electrical appliances must not touch the hot hotplates. This could cause damage to the hob and the cable insulation.

Steam pressure can be generated from the liquid between the base of the saucepan and the hotplate. The steam pressure could cause the pan to jump suddenly. There is a risk of injury.  
Always keep the hotplate and the bases of saucepans dry.

### **Cracks in the glass ceramic**

If there are fractures, flaws or cracks in the glass ceramic, there is a risk of electric shock.  
Switch off the appliance immediately.  
Isolate the appliance from the power supply at the fuse box.  
Call after-sales service.

### **The hotplate heats up, the indicator does not work**

Switch off the hotplate if the hotplate heats up but the indicator is not working. There is a risk of burning.  
Call after-sales service.

### **The hob switches off automatically**

If the hob switches itself off and can then no longer be used, disconnect it from the electricity supply immediately. The hob can be switched on again later.  
Risk of fire!  
Switch off the circuit breaker in the fuse box and call the after-sales service.

### **Incorrect repairs**

Incorrect repairs are dangerous. There is a risk of electrocution.  
Repairs may only be carried out by one of our experienced after-sales engineers.

---

## **Reasons for damage**

### **Saucepan and pan bases**

Rough pan bases scratch the glass ceramic. Check your ovenware.

Avoid cooking on the hob with an empty pan, especially with enamel and aluminium pans. This could cause damage to the saucepan bases and glass ceramic.

Observe the manufacturer's instructions when using special ovenware.

### Hot pans and saucepans

Never place hot pans or saucepans on the control panel, display area or the frame.  
This could cause damage.

### Salt, sugar and sand

Salt, sugar and sand cause scratches on the glass ceramic. Do not use the hob as a work surface or storage space.

### Hard and pointed objects

Damage can occur if hard or pointed objects fall on the hob.  
Do not store such objects above the hob.

### Food spills

Sugar and food with a high sugar content damage the hob. Remove food spills immediately with a glass scraper.  
Caution The glass scraper has a sharp blade.

### Foil and plastic

Aluminium foil or plastic containers melt on hot hobs.  
Oven protective foil is not suitable for your hob.

### Examples of possible damage

The following types of damage affect neither the cooker's function nor the stability of the glass ceramic.

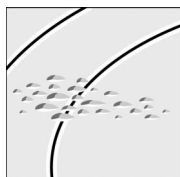

Blisters caused by melted sugar or food with a high sugar content.



Scratches caused by salt, sugar or sand particles or from rough pan bases.

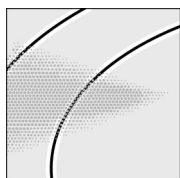

Shimmering metallic discoloration caused by pan abrasion or the use of unsuitable cleaning agents.

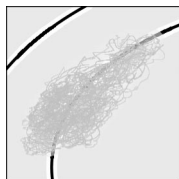

Scuffed surface caused by using unsuitable cleaning agents.

## Getting to know the appliance

An overview of models with dimensions is given on page 2.

This section describes the control panel, hotplates and displays.

### The control panel

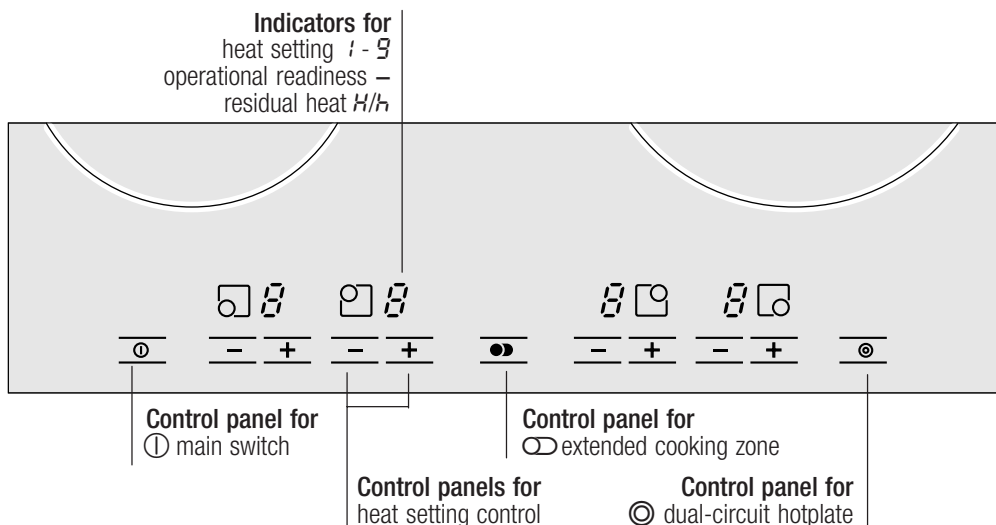

### Control panels

When you touch a symbol, the respective function is activated.

Example: Touch the Ⓞ symbol.

The outer filament circuit in the dual-circuit hotplate is switched on.



## Note

The settings remain unchanged if several symbols are touched briefly. You can therefore easily mop up spills on the control panel.

Always keep the control panels clean and dry. Moisture and dirt may impair function.

---

## The hotplates

### Single circuit hotplate

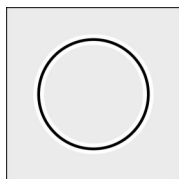



The cooking surface size of these hotplates cannot be altered.

Select the correct hotplate.  
The saucepan and hotplate sizes should match.

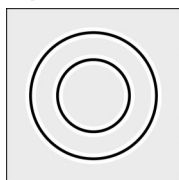
### Dual-circuit hotplate



The size of these hotplates can be altered. The hotplate must be switched on.



Switching on the outer filament circuit:  
Touch the  symbol. The indicator light lights up.  
Switching off:  
Touch the  symbol again. The indicator light goes out.

The size last set will be selected automatically when you switch on the hotplate again.

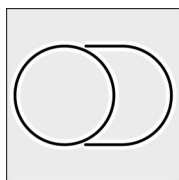
### Extended cooking zone



The extended cooking zone can be switched on when using these hotplates. The hotplate must be switched on.

Switching on the extended cooking zone:  
Touch the  symbol. The indicator light lights up.  
Switching off:  
Touch the  symbol again. The indicator light goes out.

The size last set will be selected automatically when you switch on the hotplate again.

## Halogen hotplate

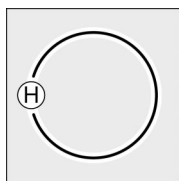

With these hotplates, the heating system reaches full power after just a few seconds.

The halogen heating ring lights up very brightly. Please do not look at the halogen light since it could blind you.

---

## Residual heat indicator

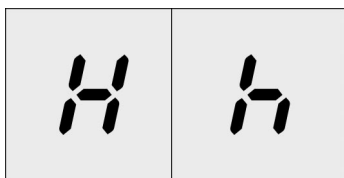

The hob has a residual heat indicator for each hotplate. It shows which hotplates are still hot. The residual heat indicator has two levels.

If an *H* appears in the display, the hotplate is still hot. You can, for example, keep a small meal warm or melt chocolate using this heat.

As the hotplate cools down further, the display changes to *h*. The display remains lit until the hotplate has cooled sufficiently.

### Caution

The residual heat indicator will no longer come on after a power cut. The hotplates could still be hot.

---

# Main switch with childproof lock

---

## Main switch

You use the using the main switch to switch on the electronics in the control panel. Now the hob is ready for use.

### Switching on

Touch the ① symbol until the – hotplate indicators light up.

### Switching off

Touch the ① symbol until the – hotplate indicators go out. All the hotplates are switched off. The residual heat indicator remains lit until the hotplates have cooled sufficiently.

### Notes

The hob switches off automatically if all the hotplates have been switched off for more than 10 seconds.

If there is still any residual heat when the hob is switched on, *H/h* and – flash alternately in the hotplate indicators.

---

## Childproof lock



You can secure the hob to stop it being switched on accidentally, preventing children from switching on the hotplates. The childproof lock remains activated permanently.

### Activating the childproof lock

Switch on the hob using the main switch.

1. Set all 4 hotplates to heat setting 2.
2. Switch off all the hotplates one by one from right to left.
3. Touch the main switch for at least 5 seconds. After this time has elapsed, the  indicator lights up for 10 seconds then goes out. The childproof lock is activated.

### Operating the hob

Touch the main switch  for longer than 4 seconds each time the hob is switched on. The  indicator flashes during this time. The hob is switched on as soon as the indicator goes out.



### Deactivating the childproof lock

You can deactivate the childproof lock again. Proceed in the same manner as for activating the childproof lock.

### Locking the hob as a one-off

You can lock the hob as a one-off, for example if when you have small children visiting.

The hob must be switched off.

Touch the  main switch for longer than 4 seconds. The hotplate indicators go out. The  indicator lights up for 10 seconds then goes out. The hob is locked.

### To unlock

Touch the  main switch for longer than 4 seconds. The hob is switched on. The hob is unlocked.

### Caution

The childproof lock can be activated or deactivated accidentally by cleaning water, spills or objects placed on the main switch .

---

# Cooking

This section describes how to adjust the hotplates. The table shows the heat settings and cooking times for various dishes. The following tips help to save energy.

## The + and – control panels

You can set the required heat setting using the + and – symbols.

Heat setting 1 = lowest setting

Heat setting 9 = highest setting.

Each heat setting has an intermediate step. This is marked by a dot.

---

## Settings

The hob must be switched on.

1. Touch the – symbol.  
 flashes in the indicator.

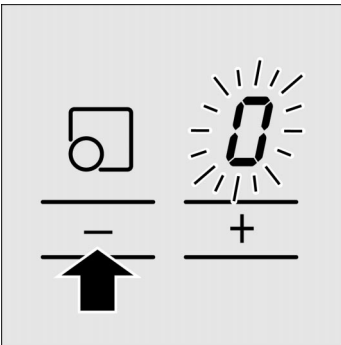

2. Touch the + or – symbol in the next 5 seconds.  
The basic setting will appear:  
+ symbol = heat setting 9  
– symbol = heat setting 4

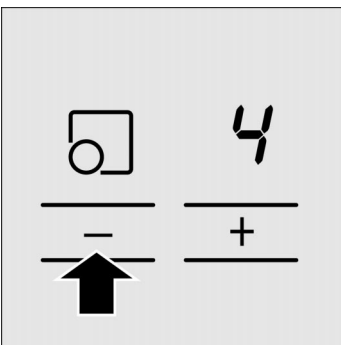

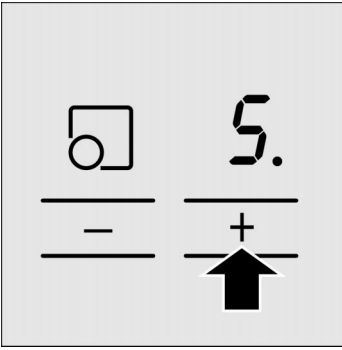

### 3. To change the heat setting:



Touch the + or – symbol until the desired heat setting appears.

#### Changing the heat setting:

You can change the heat setting at any time.

#### Switching off the hotplate.

Touch the – symbol until  appears.

If you have set a high heat setting, you can also touch the + symbol until  appears. Touch the + symbol again,  appears.

The hotplate switches off and the residual heat indicator appears after approximately 5 seconds.

## Table

The following table provides a few examples.

The cooking time may vary depending on the type of food, its weight, and quality. Deviations are therefore possible.

	Quantity	Heat setting 9	Ongoing cooking	Ongoing cooking time
<b>Melting</b>				
chocolate, chocolate coating,				
butter, honey	100 g	-	1 - 2	-
gelatine	1 pck.	-	1 - 2	-
<b>Heating</b>				
canned vegetables	400 g - 800 g	2 - 4 mins.	1 - 2	3 - 6 mins.
clear soup	500 ml - 1 ltr	3 - 4 mins.	7 - 8	2 - 4 mins.
thick soup	500 ml - 1 ltr	2 - 4 mins.	2 - 3	2 - 4 mins.
milk	200 ml - 400 ml	2 - 4 mins.	1 - 2	2 - 3 mins.

	Quantity	Heat setting 9	Ongoing cooking	Ongoing cooking time
<b>Heating and keeping warm</b>				
stew (e.g. lentil stew)	400 g - 800 g	2 - 3 mins.	1 - 2	
milk	500 ml - 1 ltr.	3 - 4 mins.	1 - 2	
<b>Defrosting and heating</b>				
frozen spinach	300 g - 600 g	4 - 5 mins.	2 - 3	5 - 15 mins.
frozen goulash	500 g - 1 kg	4 - 5 mins.	2 - 3	20 - 30 mins.
<b>Simmering</b>				
dumplings, meatballs (1 - 2 ltr. water)	4 - 8 pieces	8 - 12 mins.	4 - 5*	20 - 30 mins.
fish	300 g - 600 g	5 - 8 mins.	4 - 5*	10 - 15 mins.
<b>Cooking</b>				
rice (with double the amount of water)	125 g - 250 g	3 - 4 mins.	2 - 3	15 - 30 mins.
rice pudding (500 ml - 1 ltr. milk)	125 g - 250 g	4 - 6 mins.	1 - 2	25 - 35 mins.
potatoes boiled in their skins with 1 - 3 cups of water	750 g - 1.5 kg	5 - 7 mins.	4 - 5	25 - 30 mins.
boiled potatoes with 1 - 3 cups of water	750 g - 1.5 kg	5 - 7 mins.	4 - 5	15 - 25 mins.
fresh vegetables with 1 - 3 cups of water	500 g - 1 kg	4 - 5 mins.	2 - 3	10 - 20 mins.
pasta (1 - 2 ltr. water)	200 g - 500 g	8 - 12 mins.	6 - 7*	6 - 10 mins.
<b>Roasting</b>				
roulade	4 servings	5 - 8 mins.	4 - 5	50 - 60 mins.
pot roast	1 kg	5 - 8 mins.	4 - 5	80 - 100 mins.
goulash	500 g	6 - 11 mins.	4 - 5	50 - 60 mins.
<b>Roasting</b>				
pancakes (Fladle, Swabian pancakes)		2 - 4 mins.	6 - 7	constant roasting
cutlet, breaded	1 - 2 pieces	2 - 4 mins.	6 - 7	6 - 10 mins.
steak	2 - 3 pieces	2 - 4 mins.	7 - 8	8 - 12 mins.
fish fingers	10 pieces	2 - 4 mins.	6 - 7	8 - 12 mins.
<b>Deep-fat frying</b>				
(in 1 - 2 ltr. of oil)				
deep-frozen foods	200 g per serving	10 - 15 mins.	8 - 9	constant deep-fat frying
others	400 g per serving	10 - 15 mins.	4 - 5	constant deep-fat frying

\* Ongoing cooking without lid

---

## Tips on saving energy

### The correct saucepan size

Use saucepans and pots with thick, even bases. Uneven bases increase the cooking time.

Select the correct saucepan size for each hotplate. The diameter of the bases of the saucepans and pots should match the size of the hotplate.

Note: Ovenware manufacturers often give the diameter of the top of the saucepan. It is usually larger than the diameter of the base of the saucepan.

Use a small saucepan for small quantities. A larger, less full saucepan requires more energy.

### Using a lid

Saucepans and pots should always be covered with a suitable lid. Cooking without a lid requires much more energy.

### Cooking with small quantities of water

Cook with small quantities of water. This saves energy and helps vegetables to retain vitamins and minerals.

### Lowering the heat setting

Switch down to a lower heat setting in good time.

### Using residual heat

For longer cooking times, switch off the hotplate 5 to 10 minutes before the end of the cooking time.

As long as the residual heat indicator  $H$  is lit, you can still use the hotplate, which has already been switched off, for warming up or melting food.

---

## Cooking with the electronic boil start control

All four hotplates have an electronic boil start control.

It is no longer necessary to switch on the hotplate, wait for the pan to boil and then change the setting. You simply start with the heat setting you require for simmering.

The hotplate initially heats up using the highest heat setting, and then automatically switches back to the heat setting selected.

The time taken for the hotplate to heat up depends on the simmer setting selected.

## Setting procedure

1. Set the required ongoing cooking level for the hotplate.
2. Touch the + and - symbols at the same time. Electronic boil start control is activated.  $\overline{A}$  and the ongoing cooking level flash alternately in the display.

After the food is brought to the boil, the hotplate automatically switches back to ongoing cooking. Only the ongoing cooking level remains lit in the display.

## Tables

Refer to the following table for which appliances the electronic boil start control is suitable for.

The smaller amounts specified are suitable for the smaller hotplates, the larger amounts for the larger hotplates. The values specified are guidelines only.

<b>Appliances with electronic boil start control</b>	<b>Quantity</b>	<b>Heat setting</b>	<b>Cooking time in minutes</b>
<b>Heating</b>			
canned vegetables	400 g - 800 g	A 1 - 2	5 - 10
clear soup	500 ml - 1 ltr.	A 7 - 8	4 - 7
thick soup	500 ml - 1 ltr.	A 2 - 3	3 - 6
milk	200 ml - 400 ml	A 1 - 2	4 - 7
<b>Heating and keeping warm</b>			
stew (e.g. lentil stew)	400 g - 800 g	A 1 - 2	-
<b>Defrosting and heating</b>			
frozen spinach	300 g - 600 g	A 2 - 3	10 - 20
frozen goulash	500 g - 1 kg	A 2 - 3	20 - 30
<b>Simmering</b>			
fish	300 g - 600 g	A 4 - 5*	20 - 25
<b>Cooking</b>			
rice (with double the amount of water)	125 g - 250 g	A 2 - 3	20 - 35
boiled potatoes with 1 - 3 cups of water	750 g - 1.5 kg	A 4 - 5	30 - 40
boiled potatoes with 1 - 3 cups of water	750 g - 1.5 kg	A 4 - 5	20 - 30
fresh vegetables with 1 - 3 cups of water	500 g - 1 kg	A 2 - 3	10 - 20



<b>Appliances with electronic boil start control</b>	<b>Quantity</b>	<b>Heat setting</b>	<b>Cooking time in minutes</b>
<b>Roasting</b>			
roulade	4 pieces	A 4 - 5	50 - 60
pot roast	1 kg	A 4 - 5	80 - 100
<b>Roasting</b>			
fish fingers	10 servings	A 6 - 7	8 - 12
pancakes (Fladle, Swabian pancakes)		A 6 - 7	constant roasting
cutlet, breaded	1 - 2 servings	A 6 - 7	8 - 12

## Tips on electronic boil start control

**Food does not come to the boil using electronic boil start control.**

The electronic boil start control is designed for cooking using small quantities of water to preserve nutrients.

Add only approximately 3 cups of water to the food for large hotplates and approximately 2 cups of water for small hotplates.

Cook rice in double quantities of liquid.

Place a lid on the saucepan

Electronic boil start control is not suitable for food which is cooked in large quantities of water (e.g. noodles).

**Milk or highly frothy food boils over.**

Use a taller saucepan.

**Milk burns.**

Wash the saucepan out with cold water before filling it.

**When frying, the food sticks to the frying pan.**

Place food in a pan pre-heated to a sufficient temperature. If the fat is hot enough, it runs in streaks over the sloping base of the pan. Do not add food too early. Meat or potato fritters will break into pieces after a while.

---

# Automatic time limiter

If a hotplate is in constant use for a long time without the setting being changed, the automatic time limiter is be activated.

The hotplate heating is interrupted.  
An *F* and an *B* flash alternately in the hotplate indicator.

If you touch the + symbol, the display goes out. Now you can reset the hotplate.

The time at which the time restriction is activated depends on the heat setting (1 to 10 hours).

---

# Care and cleaning

Do not use high pressure cleaners or steam jets.

---

## Care

Clean your hob using a protective/care product for glass ceramic. It coats the cooking surface with a glossy, dirt-repellent film. Your hob will continue to look good for a long time. It makes cleaning easier.

---

## Cleaning glass ceramic

### Cleaning agents

Clean the hob after each use. This prevents food from being burnt into the hob surface.

Only use cleaning agents which are suitable for glass ceramic, e.g. CERA CLEAN, cera-fix, Sidol for ceran + steel.

Water marks can also be removed using lemon juice or vinegar.

## Unsuitable cleaning agents

Do not use:  
Abrasive sponges, scouring pads or aggressive cleaning agents, such as oven spray or stain remover.

## Glass scraper

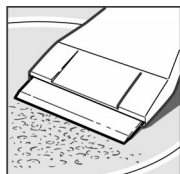

You can remove thick dirt best with a glass scraper.

Remove the protective cover from the glass scraper. Only use the blade to clean the glass ceramic surface. The casing may scratch the ceramic surface.



The blade is very sharp. There is a risk of injury. Cover the blade after cleaning.

Replace damaged blades immediately.

## How to clean the glass ceramic cooking surface

Use the glass scraper to remove food residues and grease splashes.

Use a cleaning product and kitchen towel to clean the surface when it is luke warm. If the surface is still too hot it can become stained.

Wipe the surface and rub dry with a soft cloth.

## Shimmering metallic discoloration

Discoloration is caused by pan abrasion or the use of unsuitable cleaning agents. This is very difficult to remove. Use Hob Clean or Sidol for ceran + steel. Our after-sales service can remove discoloration, but will charge for this service.

## Control panels

Always keep the control panels clean and dry. Food residues and spills can impair the function of the control panels.

---

## Cleaning the hob surround

Only use warm soapy water.

Do not use anything which is sharp or abrasive. The glass scraper is unsuitable. The hob surround could be damaged.

Neither lemon juice nor vinegar should be used for cleaning the hob surround.

This could result in matt patches.

---

# Troubleshooting

Malfunctions often have simple explanations. Please read the following instructions before calling the after-sales service:

## The hob does not work

Check that the household fuses for the appliance are OK. Check if there has been a power cut.

## The indicator light on a control panel flashes and $E$ flashes in the hotplate indicator

The control panel is very dirty, food has spilt over or there is an object on the control panel. Wipe the control panels thoroughly or remove the object. Touch the appropriate control panel. The flashing stops.

## $E$ flashes in all the hotplate indicators

The main switch was touched continuously for more than 5 seconds. Wipe the control panels thoroughly or remove the object. Reset the clock.

## The hob has switched itself off

The main switch was touched accidentally. Switch it back on. Reset the clock.

## Repairs

**Repairs may only be carried out by after-sales service technicians.**



Incorrect repairs may result in serious injury to the user.

## $E$ and numbers

If an  $E$  and numbers appear in the display panels, there is a fault with the electronics. Switch the oven off and back on again using the household fuse or the circuit breaker in the fuse box. Call the after-sales service if the display appears again.

## $F$ display and numbers

If an  $F$  and a digit flash alternately in the displays, your appliance has detected a fault. The following table contains the solutions.

---

Display	Fault	Action
$F2$	The hob is too hot and has switched itself off.	Remove the pans from the hotplates. $F2$ disappears from the display when the indicator is acknowledged (by touching a control panel) and the hotplate has cooled sufficiently. Wait a few minutes until the hotplates have cooled down slightly. If $F2$ appears again after the hotplate is switched back on, the hob is still too hot. Switch off the hotplates and allow to cool further.

Display	Fault	Action
<i>F4</i>	The hob is too hot and has switched itself off.	Check whether there is a hot pan on the control panel. Remove the pan from the control panel. Wait a few minutes until the control panel has cooled down slightly. If <i>F4</i> appears again after the hotplate is switched back on, call the after-sales service.
<i>F8</i>	The hotplate has been in constant operation for too long.	The automatic time limiter was activated. Switch off the hotplate. It can be switched on again immediately.
<i>U400</i>	The hob is connected incorrectly.	Disconnect the appliance from the mains using the household fuse or the circuit breaker in the fuse box.

## Notes:

The hotplate temperature is controlled by switching the heat on and off, this means that it is not always possible to see the red, glowing heat. If you select a low heat setting, the heat will switch off more often than at higher heat settings. The heat also switches on and off at the highest setting.

There may be a gentle buzzing as the hotplates heat up.

The heat may show differently on the individual hotplates. Depending on the angle of vision, the heat may appear to spread beyond the marked boundary of the hotplate.

These are technical features and do not influence quality or function.

Depending on the surface area of the plate, a small, uneven gap may form between the plate and the hob. For this reason, the hob has an elastic seal all the way round.

Glass ceramic may display surface area irregularities inherent to the material. The glassy surface area of the hob means that tiny blisters with a diameter of less than 1 mm appear with varying intensity. They do not affect the function or the durability of the glass ceramic hob.

---

# Packaging and old appliances

## Disposing in an environmentally-responsible manner

Unpack the appliance and dispose of the packaging in an environmentally-responsible manner.



This appliance is labelled in accordance with the European Directive 2002/96/EG concerning used electrical and electronic appliances (waste electrical and electronic equipment – WEEE).

The guideline determines the framework for the return and recycling of used appliances as applicable.

---

# After-sales service

Our after-sales service is there for you if your hob should need to be repaired. You will find the address and telephone number of your nearest after-sales service centre in the phone book. The after-sales service centres listed will also be happy to advise you of a service point in your local area.

## E number and FD number

Please quote the E number (product number) and the FD number (production number) of your appliance when contacting the after-sales service.

The rating plate bearing these numbers can be found in the appliance booklet.

---

# Acrylamide in food

Experts are currently discussing how dangerous acrylamide in food can be. We have compiled this information sheet for you on the basis of current research.

## Where does acrylamide come from?

Acrylamide in food does not come from external contamination. It is formed in the food itself during preparation - provided that the food contains carbohydrate and protein. Exactly how this happens has not yet been completely explained. However, it appears that the acrylamide content is strongly influenced by:

high temperatures  
a low water content in food  
intensive browning of the food.

## What sort of foods are affected?

Acrylamide forms mostly in grain and potato products that are prepared at high temperatures, e.g.:

crisps, chips,  
toast, rolls, bread,  
baked goods made from shortcrust pastry  
(speciality biscuits and cakes).

---

## What can you do?

You can avoid high levels of acrylamide when baking, frying and grilling.

The following recommendations were published by AID<sup>1</sup> and BMVEL<sup>2</sup> to help you minimise acrylamide levels:

### In general:

If possible, use fresh potatoes for roasting and frying. They should not have any green or sprouting areas. Do not store potatoes below 8 °C.

Cook food only until it is golden brown - "brown rather than burn"

Bake, fry or deep-fry for as short a time as possible.

The larger and thicker the food is, the less acrylamide it contains.

## Deep-fat frying

The frying temperature should not exceed 175 °C. Check the temperature using an external fat frying thermometer.

Only deep-fat fry for a short time (until the food is golden brown).

Be aware of the fried product to fat ratio. It should be 1:10 to a maximum of 1:15, e.g. approx. 100 g chips to 1.5 l cooking oil.

Soak fresh potato pieces for one hour before deep-fat frying.

## Shallow frying

Make fried potatoes using cooked potatoes. If you fry raw potatoes, use margarine instead of oil, or oil with a little margarine.

A surface thermometer is useful for checking the surface temperature in the frying pan (e.g. order number 0900.0519 from Testo).

Our advice: Heat the frying pan on heat setting 9.

When the pan has reached a temperature of 150 °C, switch back to the required high heat setting.

<sup>1</sup> AID "Acrylamide" information leaflet, published by AID (German Evaluation and Information Service for Nutrition, Agriculture and Forestry) and BMVEL (German Federal Ministry for Consumer Protection, Food and Agriculture), as at 12/02, Internet: <http://www.aid.de>.

<sup>2</sup> BMVEL press release 365, 4.12.2002, Internet: <http://www.verbraucherministerium.de>.

