





SELF-REPAIR HINTS

[en]	2
[fr]	15

Self-repair hints - Cordless handheld vacuum cleaner

 Concerning this document	3
1.1 Important information	3
1.1.1 Purpose.....	3
1.2 Explanation of symbols	3
1.2.1 Danger levels.....	3
1.2.2 Hazard symbols	3
1.2.3 Structure of the warnings.....	4
1.2.4 General symbols.....	4
 Safety	5
2.1 General Safety instructions	5
2.1.1 All domestic appliances	5
 Diagrams	6
3.1 Connection diagram.....	6
 Tools and aids	7
 Repair	8
5.1 Removing battery	8
5.2 Removing suction tube	9
5.3 Removing dust box.....	10
5.4 Removing blower motor	11
5.5 Removing brush roller.....	14

i Concerning this document

1.1 Important information

1.1.1 Purpose

These repair hints support the consumer in self-repair. They contain information on how to exchange defined spare parts including warnings, risks and safety measures that need to be followed when carrying out the self-repair.

The proper function and the safety of the appliance can be affected by an improper repair and even serious threats to life or physical condition may arise. We are not liable for damages caused by or occurring during a self-repair insofar as this damage is related to the user's carelessness or failure to follow the self-repair instructions.

For repairs on domestic appliances the approved technical regulations are applied. Any existing additional country-specific requirements and regulations must be observed. In case of doubt please contact our customer service.

1.2 Explanation of symbols

1.2.1 Danger levels

The warning levels consist of a symbol and a signal word. The signal word indicates the severity of the danger.









Warning level	Meaning
 Danger	Non-observance of the warning message will result in death or serious injuries.
 Warning	Non-observance of the warning message could result in death or serious injuries.
 Caution	Non-observance of the warning message could result in minor injuries.
Notice	Non-observance of the warning message could result in damage to property.

Table 1: Danger levels

1.2.2 Hazard symbols

Hazard symbols are symbolic representations which give an indication of the kind of danger.

The following hazard symbols are used in this document:

Hazard symbol	Meaning
	General warning message
	Danger from electrical voltage
	Risk of explosion
	Danger of cuts
	Danger of crushing

i Concerning this document



Hazard symbol	Meaning
	Danger from hot surfaces
	Danger from strong magnetic field
	Danger from non-ionizing radiation

Table 2: Hazard symbols

1.2.3 Structure of the warnings

Warnings in this document have a standardised appearance and a standardised structure.



	<div style="background-color: red; color: white; padding: 2px; text-align: center;">⚠ Danger</div> <p>Type and source of danger! Possible consequences of ignoring the danger / warning.</p> <ul style="list-style-type: none"> ▶ Measures and prohibitions for preventing the danger.
--	---

The following example shows a warning that warns against electric shock due to live parts. The measure for avoiding the danger is mentioned.

	<div style="background-color: red; color: white; padding: 2px; text-align: center;">⚠ Danger</div> <p>Risk of electric shock due to live parts! Death by electrocution</p> <ul style="list-style-type: none"> ▶ Disconnect appliances from electrical supply at least 60 seconds before starting repairs.
--	--

1.2.4 General symbols

The following general symbols are used in this document:

Gen. symbol	Meaning
	Identification of a special tip (text and/or graphic)
	Identification of a simple tip (only text)
	Identification of a link to a video tutorial





Gen. symbol	Meaning
	Identification of required tools
	Identification of required preconditions
	Identification of a condition (if ..., then ...)
	Identification of a result
[Start]	Identification of a key or button
[00123456]	Identification of a material number
Status	Identification of displayed text / window (in the appliance's display)

Table 3: General symbols

2.1 General Safety instructions

2.1.1 All domestic appliances

Risk of electric shock due to live parts!

- Errors by repairs involving electrical components can lead to electrical shock!
- Disconnect the appliance from the mains for at least 60 seconds before starting work.
- After the repair have a safety test according EN 50678 (former VDE 0701) or country-specific regulations performed.

Risk of injury from sharp edges!

- Wear protective gloves.

Risk of crushing during repair, maintenance, troubleshooting and service due to heavy and moving components

- Wear protective shoes.
- Secure heavy components from falling down.
- Do not stick body parts into moving components.

Risk to the appliance's safety / function!

- Only use original spare parts.

Risk of damage to electrostatically sensitive components (ESDs)!

- Do not touch the modules, including connections and conductor paths.

3.1 Connection diagram

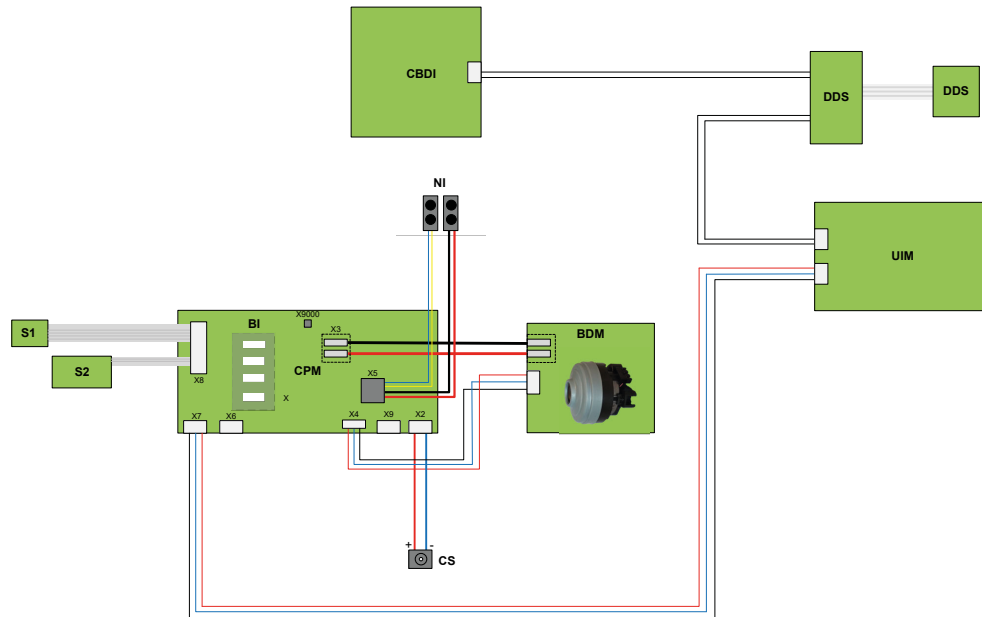





Fig. 1: Connection diagram

- CPM Control power module
- BDM Blower drive module
- UIM User interface module
- DDS Dust detection sensor
- S1 on/off board
- S2 +/- board
- BI Battery interface
- CBDI Circuit board dust illumination
- NI Nozzle interface
- CS Charging socket

Tools and aids

Designation	Details	Images
Torx-Bit TX15 [00341356]	6,3 mm (1/4")	
Auxiliary tool [15000155]	Tool for loosening out of plastic parts	
Torx-Bit TX9	6,3 mm (1/4")	

5.1 Removing battery

Prerequisite:

- ✔ Appliance is switched off.
- ▶ 1. Press battery release button (1).
- ▶ 2. Remove battery to the rear (2).

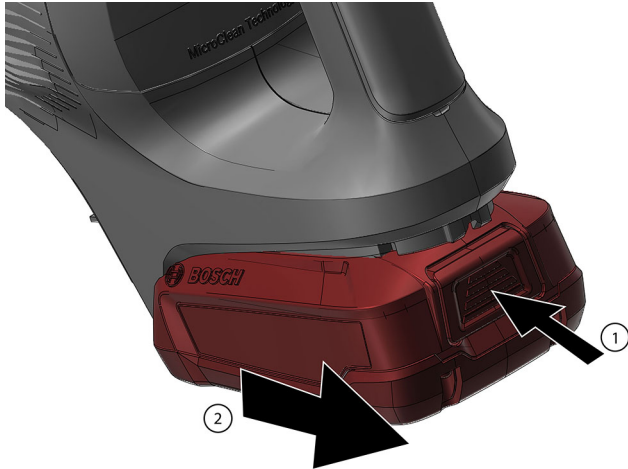

➡ Battery is removed.

5.2 Removing suction tube

- ▶ 1. Press the release button (1).
- ▶ 2. Remove suction tube to the rear (2).

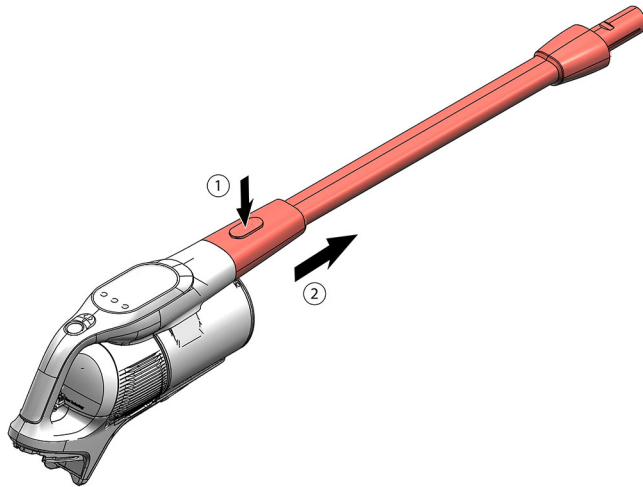

 Suction tube is removed.

5.3 Removing dust box

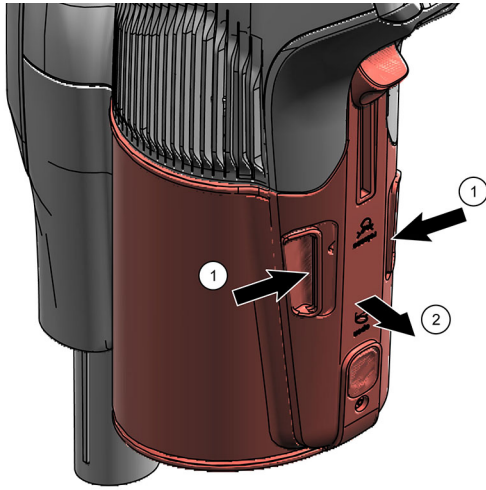

- ▶ 1. Press release button on the both side of dust container (1).
- 2. Pull out the dust container (2).



 Dust container is removed.

5.4 Removing blower motor

Suggested tools:

-  Torx-Bit TX9 6,3 mm (1/4")
-  Auxiliary tool Tool for loosening out of plastic parts [15000155]
-  Torx-Bit TX15 6,3 mm (1/4") [00341356]



Notice

Electrostatic-sensitive devices!

Fault or breakdown of components by electrostatic charges

- ▶ Before touching and measuring ESDs, use an electrostatic protection system (wristband with earth safe plug).
- ▶ Avoid allowing ESDs to come into contact with plastic materials that are capable of carrying a charge (films, etc.).
- ▶ Hold assemblies, modules and circuit boards in such a way that there is as little contact as possible with conductor strips or connectors.
- ▶ Do not place ESDs too close to monitors or televisions.
- ▶ Use only conductive materials or the original packaging for transportation.







Caution

Sharp edges!

- Cut injuries
- ▶ Wear protective gloves.

Prerequisite:

-  Appliance is switched off.
-  Battery is removed.
-  Suction tube is removed.
-  Dust box is removed.

1.



Notice

Risk of damage!

Lacquered or high-gloss surfaces.

- ▶ Act carefully when using tools. Place soft cloth underneath screwdriver blade to protect housing parts!
- ▶ Use soft cloth or towel to protect housing parts from scratches during repair!

Release hooks and remove MicroClean and status display cover.

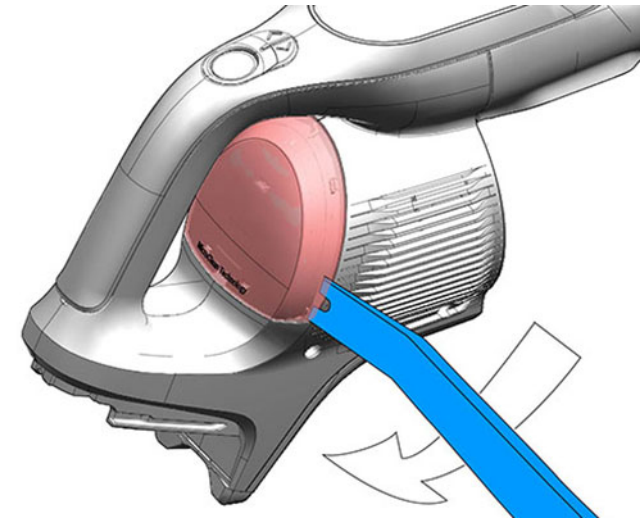

2. Release the hooks and remove the cover.

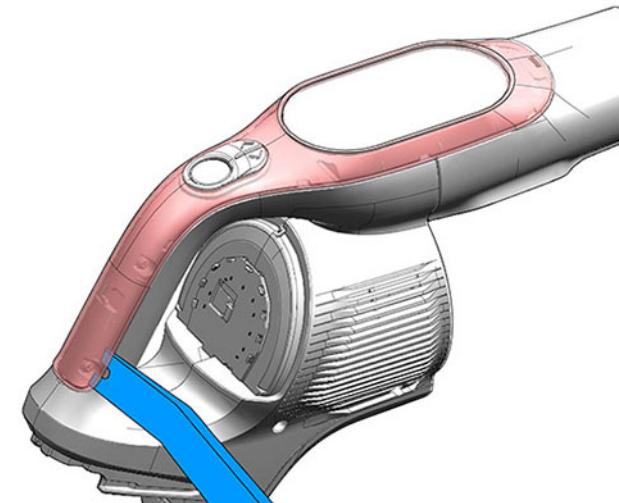

3.



If hooks were damaged during operation, air guide assembly group must be replaced.

Press and gently turn air guide cover to release hinges, then remove it.

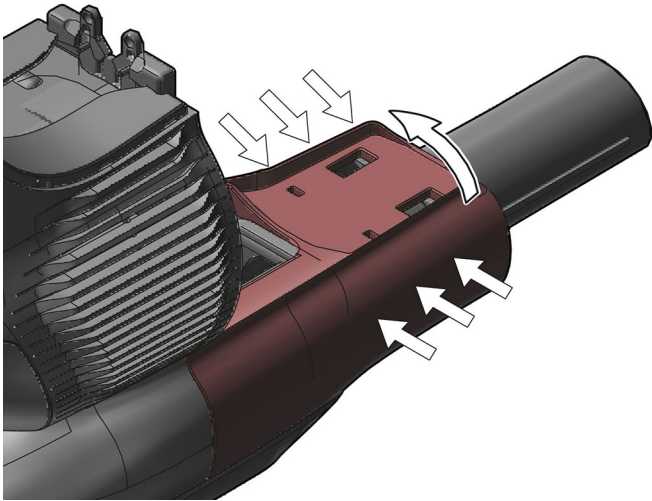

4. Release hooks and remove dust box guide.

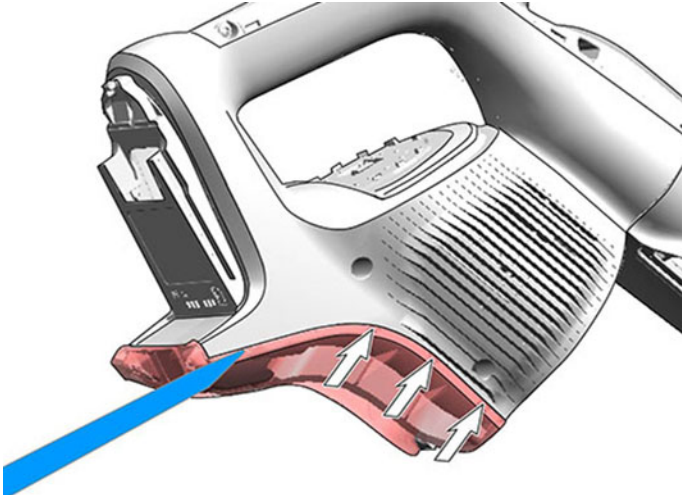

5. Unscrew eight screws.

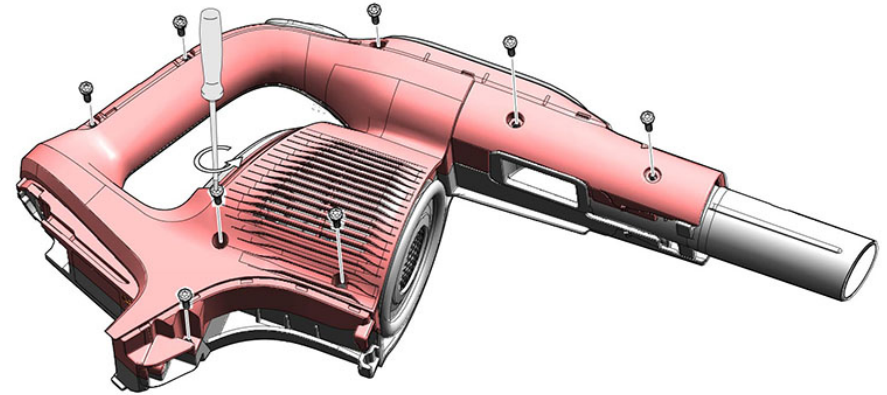

6. Remove right side cover.

7.



Replacing blower assembly group is strongly recommended due to complexity of replacing blower.

1. Disconnect electronic unit from the blower (1).
2. Remove blower assembly group (2).

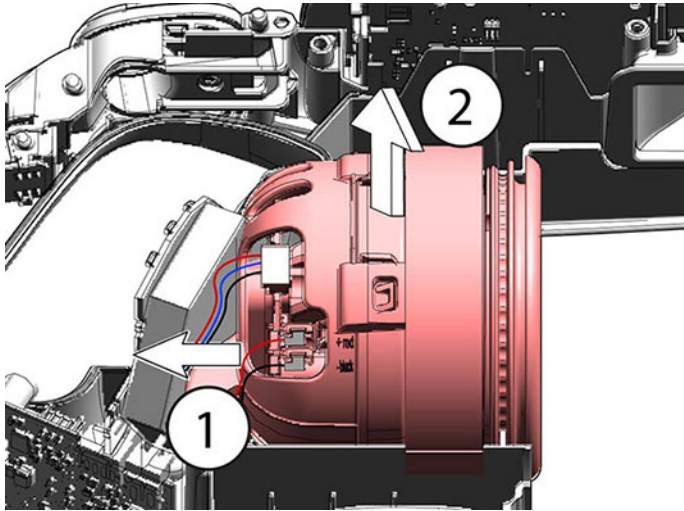

1. Lift the blower motor (1).
2. Unscrew TX9 screw from circuit board on the blower motor (2).
3. Remove blower motor from the circuit board.

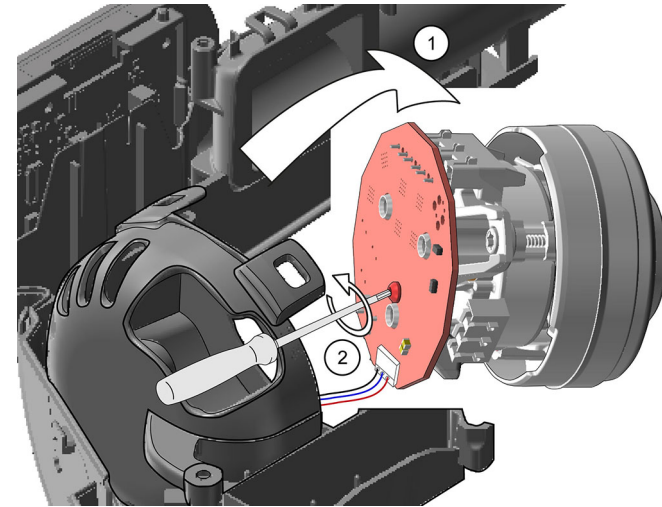

8. 1. Release two latches on blower motor housing (1).
2. Remove the upper blower motor housing (2).

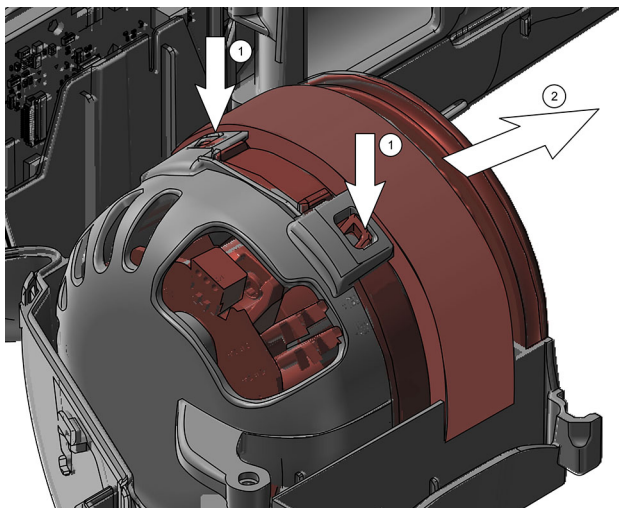

10. Remove sound insulation from the blower motor.
➔ Blower motor is removed.

9.  When replacing only the blower motor (without the assembly group), the TX9 screw must be exchanged for a new one. New TX9 screw is delivered with blower motor.

5.5 Removing brush roller

Prerequisite:

✓ Appliance is switched off.

1. Press the release button (1).
2. Pull the suction pipe out of the floor nozzle (2).

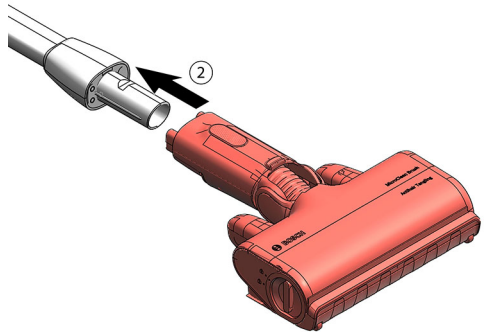
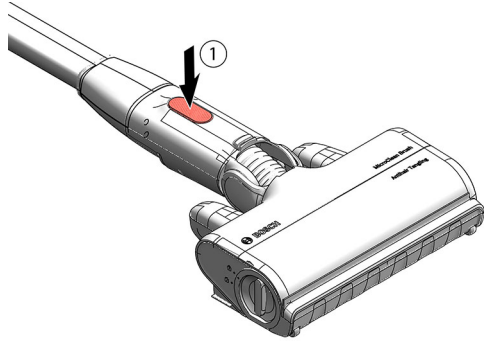



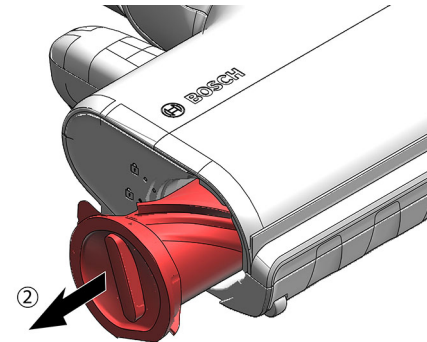
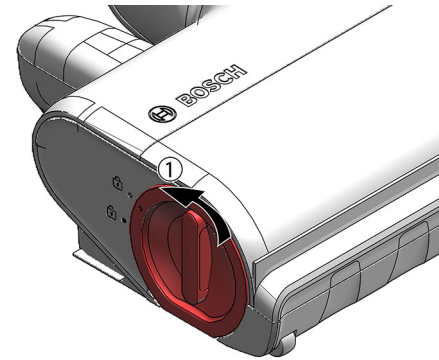

2. 1. Twist the locking mechanism on the side of floor nozzle (1).
2. Pull out the brush roller (2).



➡ Brush roller is removed.

Conseils de réparation - l'aspirateur à accus portatif

 A propos de ce document	16
1.1 Informations importantes.....	16
1.1.1 Objectif.....	16
1.2 Explication des symboles.....	16
1.2.1 Niveaux de risque.....	16
1.2.2 Symboles de danger.....	16
1.2.3 Structure des indications d'avertissement.....	17
1.2.4 Symboles généraux.....	17
 Sécurité	18
2.1 Consignes de sécurité générales.....	18
2.1.1 Tous les appareils électroménagers.....	18
 Schémas	19
3.1 Schéma de branchement.....	19
 Outils et aides	20
 Réparation	21
5.1 Retirer la batterie.....	21
5.2 Retirer le tuyau d'aspiration.....	22
5.3 Retirer le bac à poussières.....	23
5.4 Retirer le moteur du ventilateur.....	24
5.5 Retirer la brosse rotative.....	27

i A propos de ce document

1.1 Informations importantes

1.1.1 Objectif

Ces conseils de réparation aident le consommateur à résoudre les problèmes par lui-même. Ils contiennent des informations sur la manière d'échanger certaines pièces détachées, ainsi que des avertissements, les risques et les mesures de sécurité à respecter lors de l'auto-réparation.

Toute réparation non conforme peut entraver le bon fonctionnement et la sécurité de l'appareil et entraîner des risques et dangers pour l'utilisateur. Nous ne sommes pas responsables des dommages causés par ou survenant lors de l'auto-réparation, dans la mesure où ces dommages sont liés à la négligence de l'utilisateur ou au non-respect des instructions d'auto-réparation.

Lors de toute réparation sur du matériel électroménager, il convient de se conformer aux réglementations techniques habituelles. Il convient de respecter les exigences et prescriptions nationales. En cas de doute, il faut contacter notre service après-vente.

1.2 Explication des symboles

1.2.1 Niveaux de risque

Les niveaux de risque se composent d'un symbole et d'un terme d'avertissement. Le mot d'avertissement caractérise la gravité du danger.







Niveau de dangerosité	Signification
 DANGER	Le non respect de la consigne d'avertissement provoque la mort ou des blessures graves.
 AVERTISSEMENT	Le non respect de la consigne d'avertissement peut provoquer la mort ou des blessures graves.
 PRUDENCE	Le non respect de la consigne d'avertissement peut provoquer des blessures légères.
ATTENTION !	Le non respect de la consigne d'avertissement peut provoquer des dégâts matériels.

Tableau 1: Niveaux de risque

1.2.2 Symboles de danger

Les symboles de danger sont des représentations figuratives renseignant sur la nature du danger.

Ce document utilise les symboles de danger suivants:

Symbole de danger	Signification
	Consigne d'avertissement générale
	Danger engendré par la tension électrique
	Risque d'explosion
	Risque de blessures par coupure

i A propos de ce document





Symbole de danger	Signification
	Risque de blessures par écrasement
	Danger engendré par des surfaces très chaudes
	Danger engendré par un champ magnétique puissant
	Danger engendré par un rayonnement non ionisant

Tableau 2: Symboles de danger

1.2.3 Structure des indications d'avertissement

Les consignes d'avertissement figurant dans ce document ont un aspect uniforme et une structure uniforme.

	<p> DANGER</p> <p>Type et source du danger ! Conséquences possibles en cas de non-respect du danger / de l'avertissement.</p> <ul style="list-style-type: none"> ▶ Mesures et interdictions pour éviter le danger.
--	--

L'exemple suivant montre une consigne d'avertissement mettant en garde contre le risque d'électrocution. La mesure permettant d'éviter le danger est nommée.

	<p> DANGER</p> <p>Risque d'électrocution par des pièces conductrices de tension ! Mort par électrocution.</p> <ul style="list-style-type: none"> ▶ Débrancher l'appareil du secteur minimum 60 secondes avant de démarrer la réparation.
--	--

1.2.4 Symboles généraux

Les symboles généraux suivants sont utilisés dans ce document :











Symbole général	Signification
	Identification d'une astuce spéciale (texte et/ou graphique)
	Identification d'une astuce simple (uniquement texte)
	Identification d'un lien pour un tutoriel vidéo
	Identification des outils requis
	Identification des conditions préalables requises
	Identification d'une condition (si... alors...)
	Identification d'un résultat
	Identification d'une touche ou un bouton
	Identification d'une référence de pièce
	Identification du texte ou de la fenêtre affiché (sur l'affichage de l'appareil)

Tableau 3: Symboles généraux

2.1 Consignes de sécurité générales

2.1.1 Tous les appareils électroménagers

Risque d'électrocution en raison de pièces sous tension !

- La réparation de composants électriques comporte un risque d'électrocution !
- Débrancher l'appareil du secteur minimum 60 secondes avant de commencer la réparation.
- Après la réparation, effectuer un test de sécurité selon EN 50678 (anciennement VDE 0701) ou les réglementations spécifiques nationales.

Risque de coupure sur des bords tranchants!

- Porter des gants de protection.

Risque de casse durant la réparation, maintenance, dépannage et SAV en raison de composants lourds et mobiles

- Porter des chaussures de protection.
- Sécuriser les composants lourds contre le risque de chute.
- Ne pas coller les pièces du châssis sur les composants mobiles.

Risque lié à la sécurité/au fonctionnement de l'appareil!

- Utiliser uniquement des pièces de rechange d'origine.

Risque d'endommagement des composants sensibles aux décharges électrostatiques !

- Ne pas toucher les modules, ni leurs connexions et pistes conductrices.

3.1 Schéma de branchement

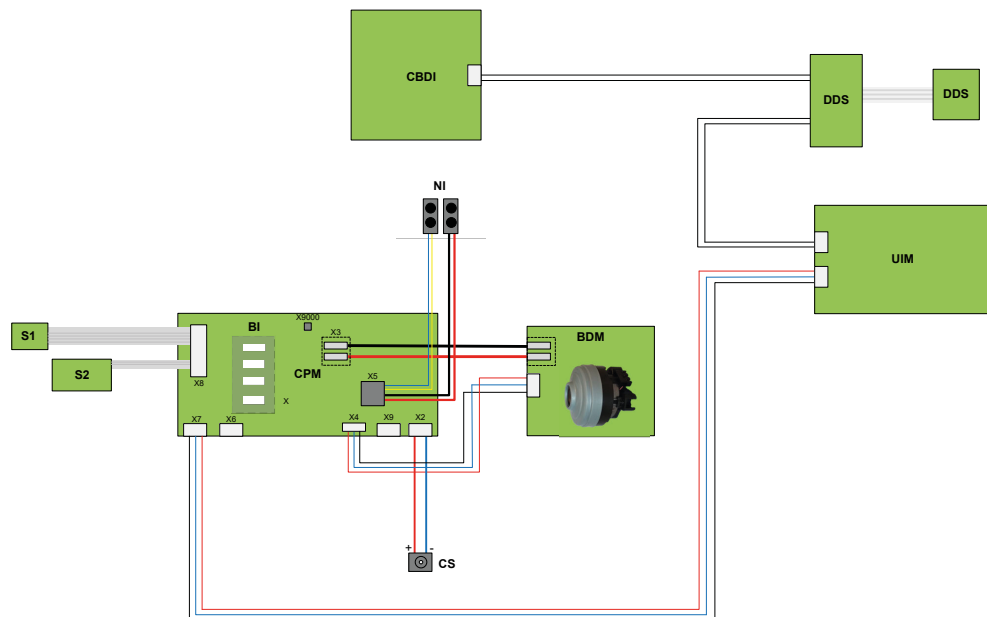





Fig. 1: Schéma de branchement

- CPM Module contrôle et puissance
- BDM Module d'entraînement du ventilateur
- UIM Module interface utilisateur
- DDS Capteur de détection de poussière
- S1 platine on/off
- S2 platine +/-
- BI Interface batterie
- CBDI Éclairage de la poussière du circuit imprimé
- NI Interface de la buse
- CS Prise de charge

Outils et aides

Désignation	Détails	Images
Embout Torx TX15 [00341356]	6,3 mm (1/4")	
Outil auxiliaire [15000155]	Cale de montage pour démonter les pièces en plastique	
Embout Torx TX9	6,3 mm (1/4")	

5.1 Retirer la batterie

Pré-requis:

- ✔ L'appareil est éteint.
- ▶ 1. Appuyer sur le bouton de déblocage de la batterie (1).
- ▶ 2. Retirer la batterie par l'arrière (2).

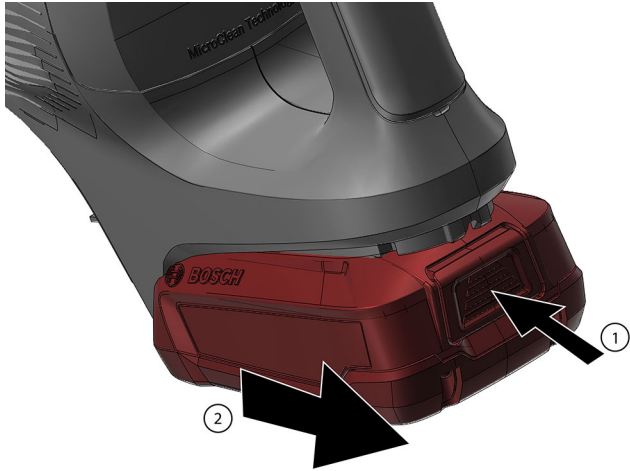

➡ La batterie est retirée.

5.2 Retirer le tuyau d'aspiration

- ▶ 1. Appuyer sur le bouton de déblocage (1).
- ▶ 2. Retirer le tuyau d'aspiration à l'arrière (2).

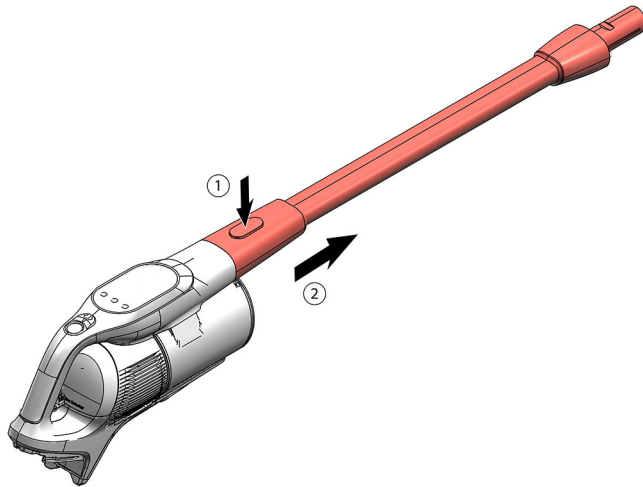

 Le tuyau d'aspiration est retiré.

5.3 Retirer le bac à poussières

- ▶ 1. Appuyer sur le bouton de déblocage sur les deux côtés du bac à poussières (1).
- 2. Retirer le bac à poussières (2).

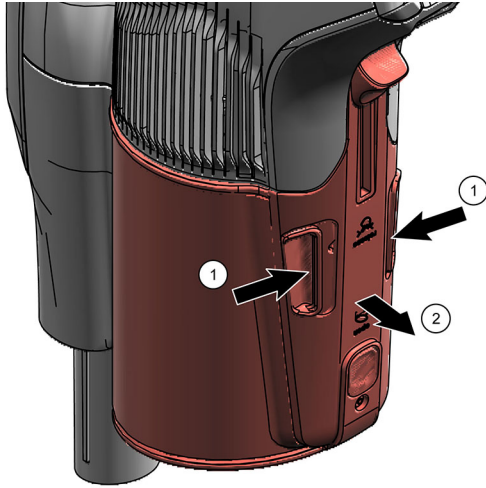

 Le bac à poussières est retiré.

5.4 Retirer le moteur du ventilateur

Outillage suggéré:

- 🔧 Embout Torx TX9 6,3 mm (1/4")
- 🔧 Outil auxiliaire Cale de montage pour démonter les [15000155]
pièces en plastique
- 🔧 Embout Torx TX15 6,3 mm (1/4") [00341356]



ATTENTION !

Composants sensibles aux décharges électrostatiques !

- Défaut ou panne de composants en raison de charges électrostatiques.
- ▶ Avant tout contact et mesure de ces composants, utiliser un système de protection électrostatique (ex. bracelet de mise à la terre).
 - ▶ Empêcher tout contact entre ces composants et les matériaux plastiques capables de supporter une charge (films, etc.).
 - ▶ Maintenir les groupes de composants, modules et platines de sorte qu'il y ait le moins de contact possible avec les bandes conductrices ou connecteurs.
 - ▶ Ne pas placer ces composants trop proches de moniteurs ou télévisions.
 - ▶ Utiliser pour le transport uniquement des matériaux conducteurs ou l'emballage d'origine.



⚠️ PRUDENCE

Arêtes vives !

- Blessures par coupure
- ▶ Porter des gants de protection.

Pré-requis:

- ✔ L'appareil est éteint.
- ✔ La batterie est retirée.
- ✔ Le tuyau d'aspiration est retiré.
- ✔ Le bac à poussières est retiré.

1.



ATTENTION !

Risque de dommage !

Surfaces laquées ou brillantes.

- ▶ Utiliser les outils avec prudence. Placer un tissu doux sous la lame du tournevis pour protéger les pièces du boîtier !
- ▶ Utiliser un tissu ou chiffon doux pour protéger les pièces du boîtier contre le risque de rayures durant la réparation!

Débloquer les crochets et retirer le MicroClean et le couvercle de l'affichage du statut.

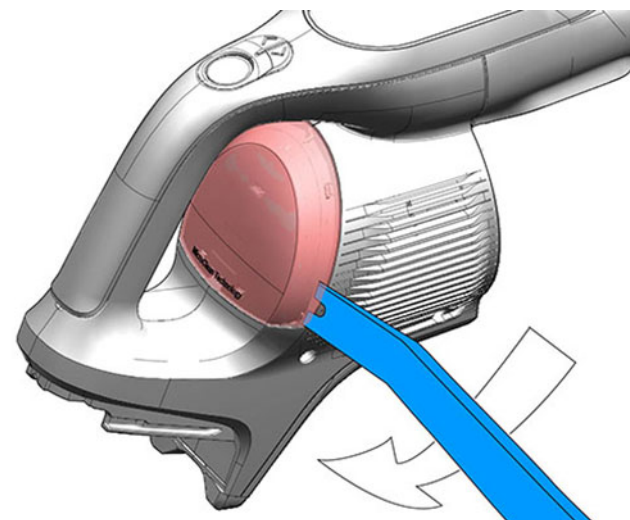

2. Débloquer les crochets et retirer le couvercle.

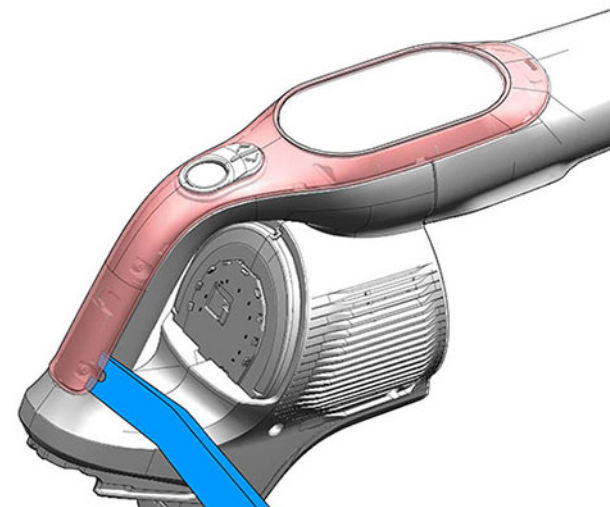

3.



Si les crochets ont été endommagés pendant le fonctionnement, il faut remplacer le groupe d'assemblage du guide d'air.

Réparation

Appuyer sur le couvercle du guide d'air et le tourner doucement pour libérer les charnières, puis le retirer.

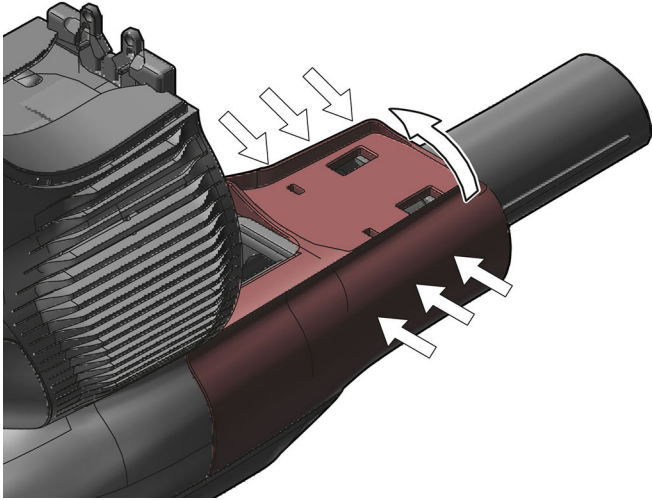

4. Débloquer les crochets et retirer le guide du bac à poussières.

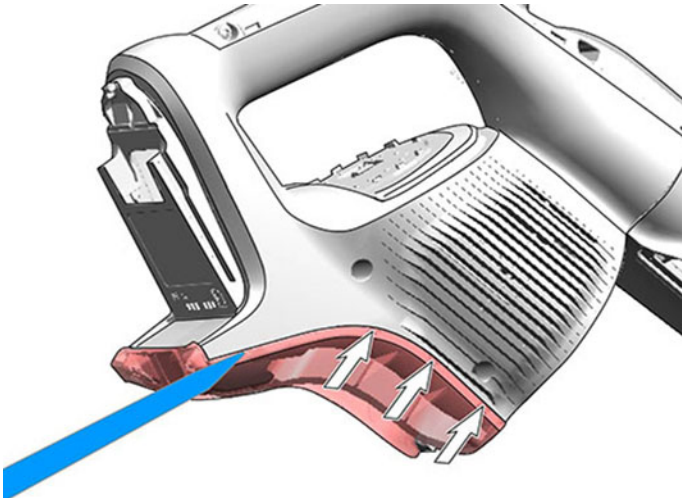

5. Dévisser huit vis.

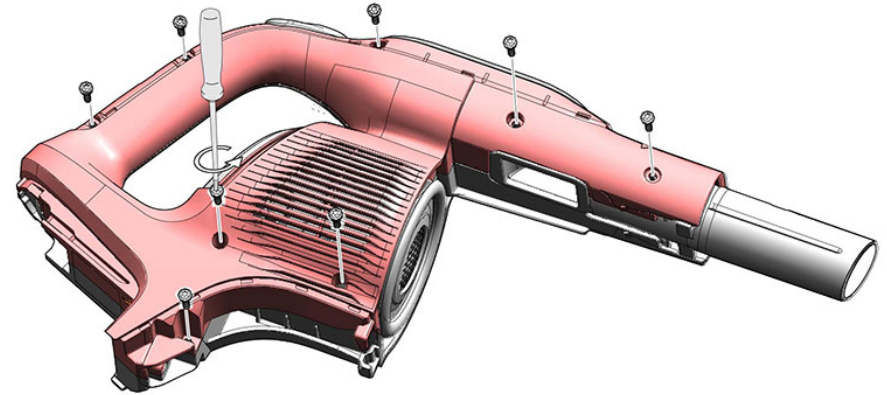

6. Retirer le couvercle de protection latéral.

7.



Il est fortement recommandé de remplacer le groupe d'assemblage du ventilateur en raison de la complexité du remplacement du ventilateur même.

Réparation

1. Débrancher l'unité électronique du ventilateur (1).
2. Retirer le groupe d'assemblage du ventilateur (2).

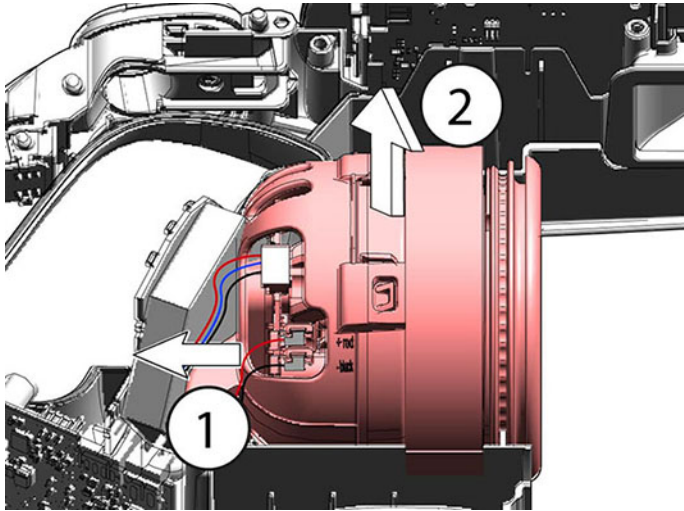

8. 1. Déverrouiller les deux loquets du boîtier du moteur du ventilateur (1).
2. Retirer le boîtier du moteur du ventilateur supérieur (2).

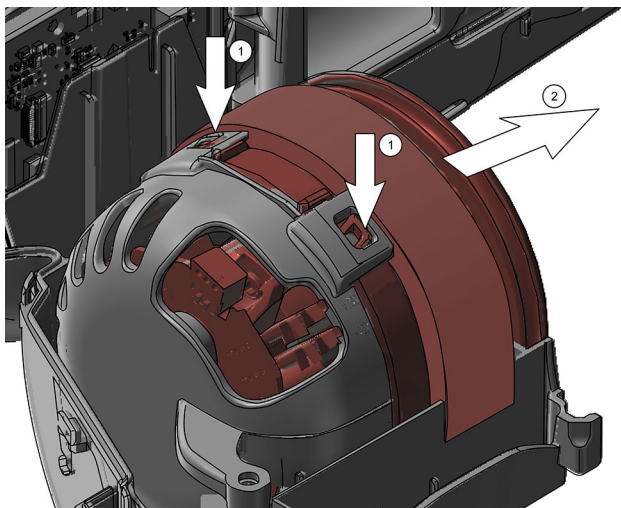

9.

	En cas de remplacement du seul moteur de la soufflerie (sans le groupe d'assemblage), la vis TX9 doit être remplacée par une neuve. La nouvelle vis TX9 est livrée avec le moteur du ventilateur.
---	--

1. Soulever le moteur du ventilateur (1).
2. Dévisser la vis TX9 de la carte de circuit imprimé du moteur du ventilateur (2).
3. Retirer le moteur du ventilateur de la carte de circuit imprimé.

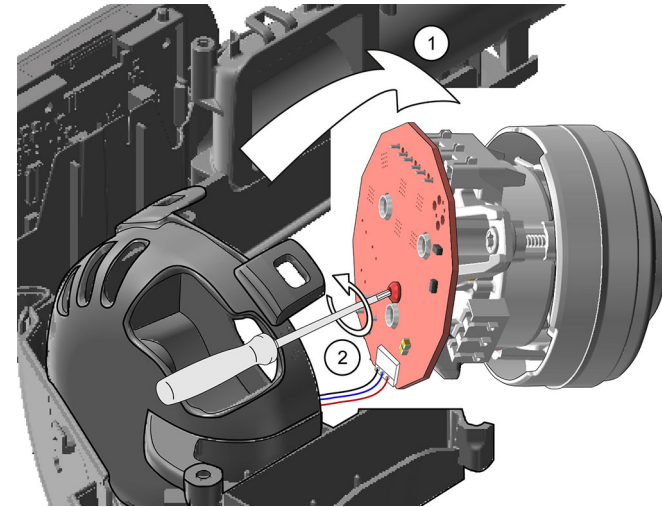

10. Retirer l'isolation acoustique du moteur du ventilateur.
➡ Le moteur du ventilateur est retiré.

5.5 Retirer la brosse rotative

Pré-requis:

✓ L'appareil est éteint.

1. Appuyer sur le bouton de déblocage (1).
2. Sortir le tuyau d'aspiration de la brosse de sol (2).

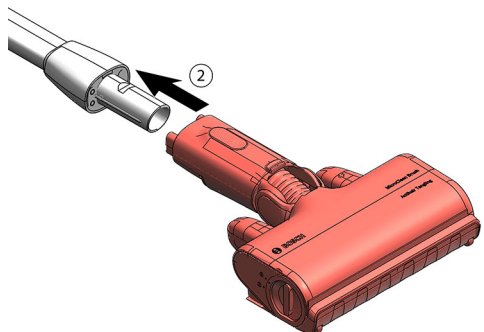
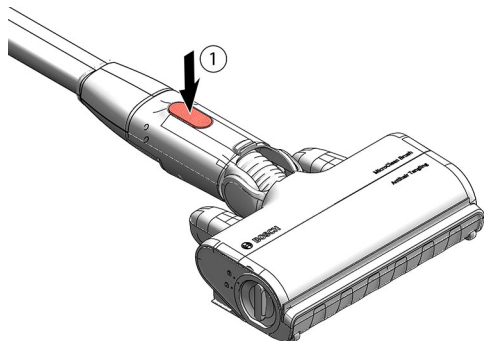

2. 1. Tourner le mécanisme de verrouillage sur le côté de la brosse de sol (1).
2. Retirer la brosse rotative (2).

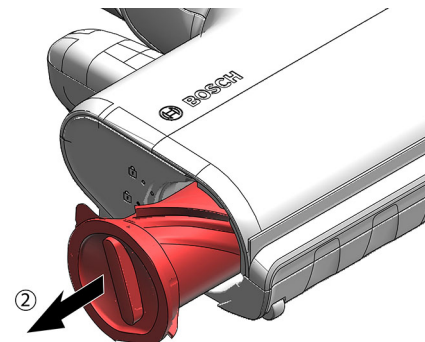
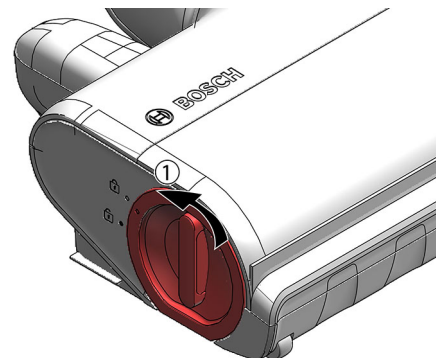

➡ La brosse rotative est retirée.