





SELF-REPAIR HINTS

[bg]	Съвети за ремонт	2
[hr]	Savjeti za popravak	32
[cs]	Poznámky k opravě	62
[da]	Tip til reparation	92
[nl]	Reparatie informatie	121
[en]	Self-repair hints	151
[et]	Remonditeave	180
[fi]	Korjausvinkit	209
[fr]	Conseils de réparation	239
[de]	Reparatur Hinweise	269
[el]	Υποδείξεις επισκευής	299
[hu]	Javítási útmutató	329
[it]	Consigli di riparazione	359
[lv]	Informācija par remontu	389
[lt]	Informacija apie remontą	418
[no]	Reparasjonstips	447
[pl]	Wskazówki naprawy	476
[pt]	Dicas de resolução	506
[ro]	Indicii pentru reparații	536
[sk]	Poznámky k opravám	566
[sl]	Nasveti za popravilo	596
[es]	Consejos de reparación	626
[sv]	Reparationsinformation	656
[tr]	Onarım İpuçları	685

Съвети за ремонт - Хладилник с фризер

 Относно този документ	3	4.8 Смяна на табличката за бутилки	20
1.1 Важна информация.....	3	4.8.1 Сваляне на табличката за бутилки	20
1.1.1 Цел.....	3	4.8.2 Монтиране на табличката за бутилки	20
1.2 Обяснение на символите	3	4.9 Смяна на стелаж на вратата	21
1.2.1 Нива на опасност	3	4.9.1 Изваждане на стелаж на вратата.....	21
1.2.2 Символи за опасност.....	3	4.9.2 Монтиране на стелаж на вратата.....	21
1.2.3 Структура на предупрежденията	4	4.10 Смяна на контейнера за съхранение.....	22
1.2.4 Общи символи.....	4	4.10.1 Отстраняване на контейнера за съхранение	22
 Безопасност	5	4.10.2 Поставяне на контейнера за съхранение.....	22
2.1 Общи инструкции за безопасност	5	4.11 Смяна на контейнера за плодове и зеленчуци	23
2.1.1 Всички домашни уреди.....	5	4.11.1 Изваждане на контейнера за плодове и зеленчуци	23
 Инструменти и помощни средства	6	4.11.2 Монтиране на контейнера за плодове и зеленчуци	23
 Ремонт	7	4.12 Смяна на лавицата над контейнера за плодове и зеленчуци.....	24
4.1 Смяна на уплътнителя на вратата	7	4.12.1 Отстраняване на лавицата над контейнера за плодове и зеленчуци	24
4.1.1 Сваляне на уплътнителя на вратата	7	4.12.2 Поставяне на лавицата над контейнера за плодове и зеленчуци.....	25
4.1.2 Монтиране на уплътнителя на вратата	7	4.13 Смяна на контейнера за замразени хранителни продукти	26
4.2 Смяна на дръжката на вратата	10	4.13.1 Изваждане на контейнера за замразени хранителни продукти.....	26
4.2.1 Изваждане на дръжката на вратата	10	4.13.2 Монтиране на контейнера за замразени хранителни продукти.....	26
4.2.2 Монтиране на дръжката на вратата	10	4.14 Смяна на горната LED лампа	27
4.3 Смяна на горната панта на вратата	11	4.14.1 Отстраняване на горната LED лампа.....	27
4.3.1 Сваляне на горната панта на вратата	11	4.14.2 Поставяне на горната LED лампа	27
4.3.2 Монтиране на горната панта на вратата	12	4.15 Смяна на страничната LED лампа	28
4.4 Смяна на горната панта на вратата (врата с дисплей)	13	4.15.1 Отстраняване на страничната LED лампа	29
4.4.1 Сваляне на горната панта на вратата	14	4.15.2 Поставяне на страничната LED лампа.....	29
4.4.2 Монтиране на горната панта на вратата	15	4.16 Смяна на LED лампата на фризера	31
4.5 Смяна на средната панта на вратата	16	4.16.1 Отстраняване на LED лампата на фризера	31
4.5.1 Сваляне на средната панта на вратата.....	16	4.16.2 Поставяне на LED лампата на фризера	31
4.5.2 Монтиране на средната панта на вратата	17		
4.6 Смяна на долната панта на вратата	18		
4.6.1 Сваляне на долната панта на вратата	18		
4.6.2 Монтиране на долната панта на вратата	18		
4.7 Смяна на рафта.....	19		
4.7.1 Изваждане на рафта	19		
4.7.2 Монтиране на рафта	19		

i Относно този документ

1.1 Важна информация

1.1.1 Цел

Тези съвети за ремонт помагат на потребителя да ремонтира сам уреди в съответствие с регламента за екологосъобразно проектиране на уредите (от 03.2021 г.).

Те съдържат информация как да сменят определени резервни части, включително предупреждения и рискове.

Ако имате някакви въпроси, моля свържете се с нашия отдел за обслужване на клиенти. Ние носим отговорност за щети, само ако съветите за ремонт са спазени правилно.

1.2 Обяснение на символите

1.2.1 Нива на опасност

Предупредителните нива се състоят от символ и сигнална дума. Сигналната дума показва сериозността на опасността.





Ниво на предупреждение	Значение
 ОПАСНОСТ	Неспазването на предупредителното съобщение ще доведе до смърт или сериозни наранявания.
 ПРЕДУПРЕЖДЕНИЕ	Неспазването на предупредителното съобщение може да доведе до смърт или сериозни наранявания.
 ВНИМАТЕЛНО	Неспазването на предупредителното съобщение може да доведе до леки наранявания.
ВНИМАНИЕ!	Неспазването на предупредителното съобщение може да доведе до имуществени щети.

Таблица 1: Нива на опасност

1.2.2 Символи за опасност

Символите за опасност са символични изображения, които дават индикация за вида опасност.

В този документ се използват следните символи за опасност:

Символ за опасност	Значение
	Общо предупредително съобщение
	Опасност от електрическо напрежение
	Риск от експлозия
	Опасност от порязвания

i Относно този документ





Символ за опасност	Значение
	Опасност от премазване
	Опасност от горещи повърхности
	Опасност от силно магнитно поле
	Опасност от нейонизиращо лъчение

Таблица 2: Символи за опасност

1.2.3 Структура на предупрежденията

Предупрежденията в този документ имат стандартизиран външен вид и стандартизирана структура.

	<p>ОПАСНОСТ</p> <p>Вид и източник на опасността! Възможни последици от игнориране на опасността/предупреждението.</p> <ul style="list-style-type: none"> ▶ Мерки и забрани за предотвратяване на опасността.
--	---

Следният пример показва предупреждение, което уведомява за токов удар, предизвикан от части под напрежение. Споменава се мярката за избягване на опасността.

	<p>ОПАСНОСТ</p> <p>Риск от токов удар поради части под напрежение! Смърт от токов удар</p> <ul style="list-style-type: none"> ▶ Изключете уредите от електрическото захранване поне 60 секунди преди започване на ремонта.
--	---

1.2.4 Общи символи

В този документ се използват следните общи символи:







Общ символ	Значение
	Идентифициране на специален съвет (текст и/или графика)
	Идентифициране на прост съвет (само текст)
	Идентифициране на връзка към видео урок
	Идентифициране на необходимите инструменти
	Идентифициране на необходимите предварителни условия
	Идентифициране на условие (ако ..., тогава ...)
	Идентифициране на резултат
Старт	Идентифициране на ключ или бутон
[00123456]	Идентифициране на каталожен номер
Статус	Идентифициране на показания текст/прозорец (на дисплея на уреда)

Таблица 3: Общи символи

2.1 Общи инструкции за безопасност

2.1.1 Всички домашни уреди

Риск от токов удар поради части под напрежение!

- Грешки при ремонти, включващи електрически компоненти, могат да доведат до токов удар!
- Разкачете уреда от електрическата мрежа за поне 60 секунди, преди да започнете работа.
- След ремонта трябва да се извърши проверка за безопасност съгласно VDE 0701 или в съответствие със специфичните за страната разпоредби.

Риск от нараняване от остри ръбове!

- Носете предпазни ръкавици.

Риск от премазване по време на ремонт, поддръжка, отстраняване на неизправности и сервиз поради тежки и движещи се компоненти

- Носете защитни обувки.
- Закрепете тежките компоненти, така че да не паднат.
- Не позволявайте контакт на части от тялото с движещи се компоненти.

Риск за безопасността/функцията на уреда!

- Използвайте само оригинални резервни части.

Риск от повреда на електростатично чувствителни компоненти (ESD)!

- Не докосвайте модулите, включително връзки и проводникови пътища.

Инструменти и помощни средства

посочване	Подробности	Изображения
Накрайник Torx TX20 [00340865]	6,3 мм (1/4")	
Специален инструмент [00342180]		

4.1 Смяна на уплътнителя на вратата

Изискване:

- ✔ Вратата е отворена.

4.1.1 Сваляне на уплътнителя на вратата

1. Освободете уплътнителя на вратата от жлеба отляво и отдясно.

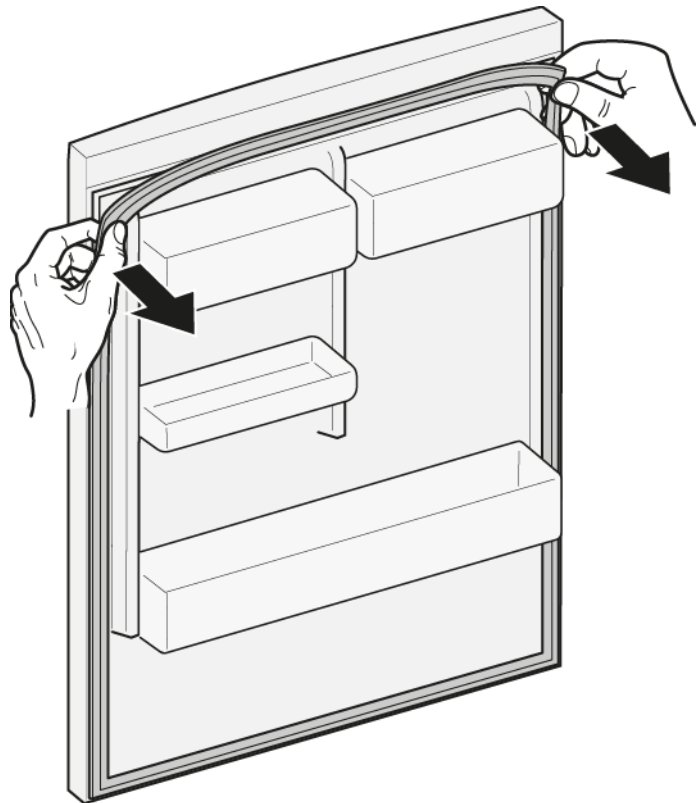

2. Извадете уплътнителя на вратата от жлеба.

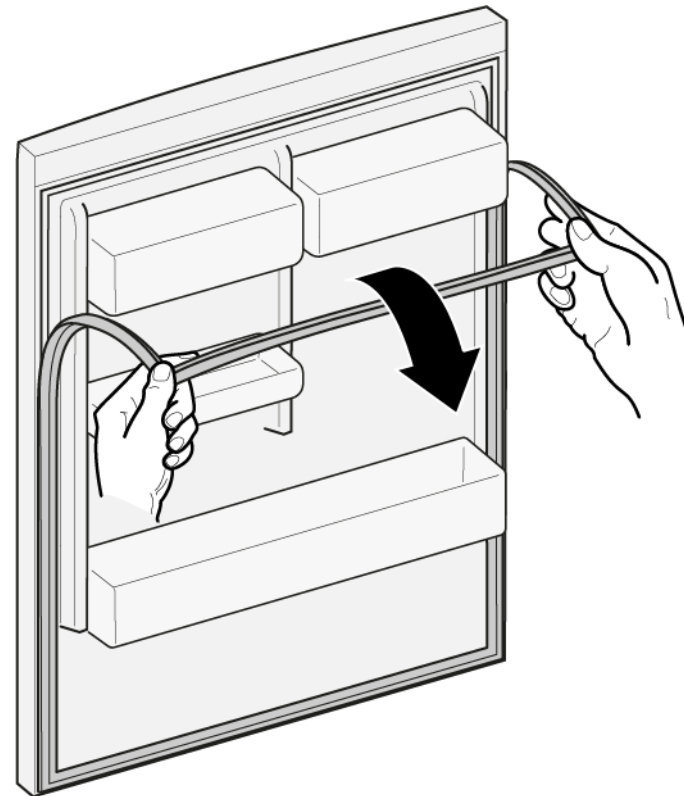

- ➡ Уплътнителят на вратата е свален.

4.1.2 Монтиране на уплътнителя на вратата



Дебелината на новия уплътнител на вратата може леко да се отличава от тази на стария уплътнител. Това няма да повлияе на начина на затваряне и нейната работа в дългосрочен план.

Ако вашият уред има регулируеми панти или приставки за панти, можете да оптимизирате начина на затваряне по-късно.

Малките странични отвори в уплътнителя на вратата са функционални (необходими за вентилация). Те не са производствени грешки.

1. Проверете жлеба на уплътнителя за повреди.



4. Натиснете ъглите на уплътнителя отгоре и отдолу към жлеба.

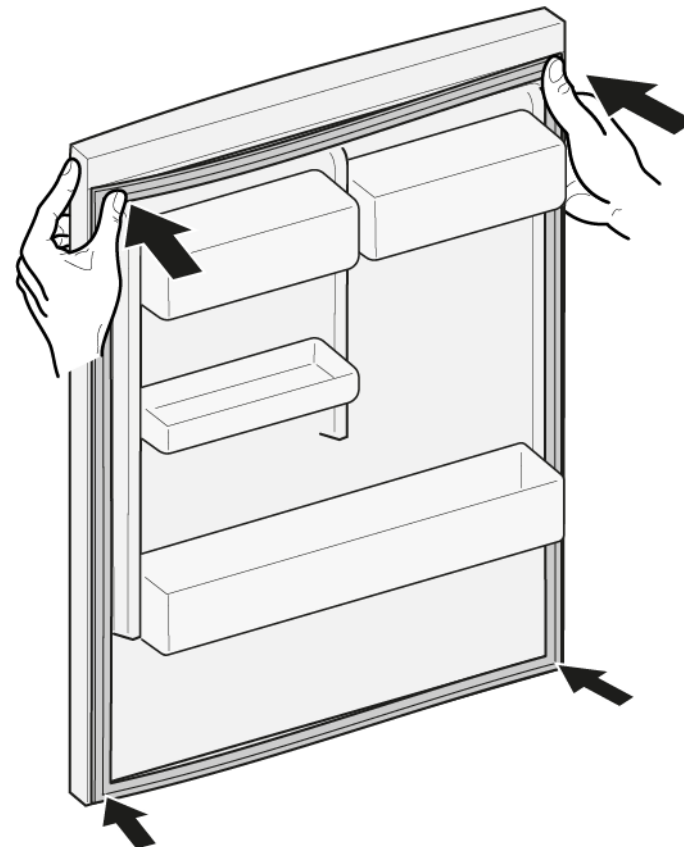

2.  Ако жлебът на уплътнителя е повреден:
- Свържете се с отдела за обслужване на клиенти.

3.  Леката деформация на уплътнителя на вратата е нормална и не засяга неговата функция. Препоръчително е да изправите уплътнителя на вратата, преди да го поставите в уреда.

Загрейте уплътнителя на вратата със сешоар или гореща вода и променете формата му.



5. Постепенно вкарайте с натискане целия уплътнител в жлеба.





 Уплътнителят на вратата е монтиран.

4.2 Смяна на дръжката на вратата

Специални инструменти:

-  Накрайник Torx TX20 6,3 мм (1/4") [00340865]
-  Плоска отвертка Врѝх 10 мм x 1,6 мм x 200 мм

Изискване:

-  Уредът е изключен от захранването.
-  Вратата е отворена.

4.2.1 Изваждане на дръжката на вратата

- ▶ 1. Свалете двете капачки на винтовете (1).
- ▶ 2. Развийте двата винта (2).
- ▶ 3. Свалете дръжката на вратата (3).

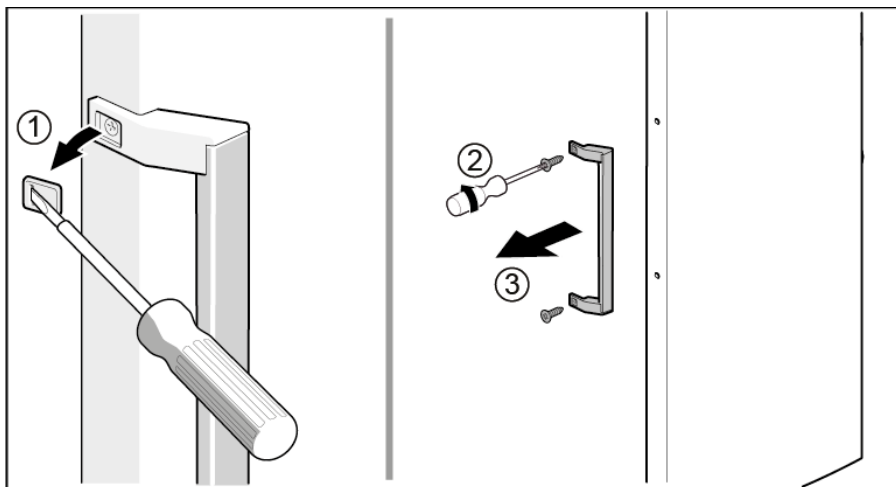

 Дръжката на вратата е свалена.



Дръжката на втората врата може да бъде свалена по същия начин.

4.2.2 Монтиране на дръжката на вратата

- ▶ Монтирайте в обратен ред.

4.3 Смяна на горната панта на вратата

Специални инструменти:

 Накрайник Torx TX20 6,3 мм (1/4") [00340865]

	<p>⚠ ПРЕДУПРЕЖДЕНИЕ</p> <p>Тежки, обемисти уреди! Травми на гърба и мускулите</p> <ul style="list-style-type: none"> ▶ Операцията по отстраняване на вратите на уреда трябва да се извършва само от обучени специалисти. ▶ За преместването на уреда са необходими двама души. ▶ Използвайте само подходящи инструменти и оборудване.
--	--



	<p>⚠ ВНИМАТЕЛНО</p> <p>Остри ръбове! Наранявания от порязване</p> <ul style="list-style-type: none"> ▶ Носете предпазни ръкавици.
--	--

	<p>⚠ ПРЕДУПРЕЖДЕНИЕ</p> <p>Приплъзване на наклонени уреди! Костни фрактури/наранявания от премазване</p> <ul style="list-style-type: none"> ▶ Укрепете уредите срещу приплъзване.
--	--

	<p>⚠ ВНИМАТЕЛНО</p> <p>Риск от падащи части поради разхлабени винтове! Нараняване поради падащи части.</p> <ul style="list-style-type: none"> ▶ Закрепете компонента, така че да не падне.
---	---

	<p>ВНИМАНИЕ!</p> <p>Риск от падащи части поради разхлабени винтове! Повреда на други части на уреда или в дома на клиента, напр. дъното.</p> <ul style="list-style-type: none"> ▶ Закрепете компонента, така че да не падне.
--	---

Изискване:

-  Уредът е изключен от захранването.
-  Вътрешните фитинги на уреда са отстранени.

4.3.1 Сваляне на горната панта на вратата

1. Плъзнете опорна част под основната секция.

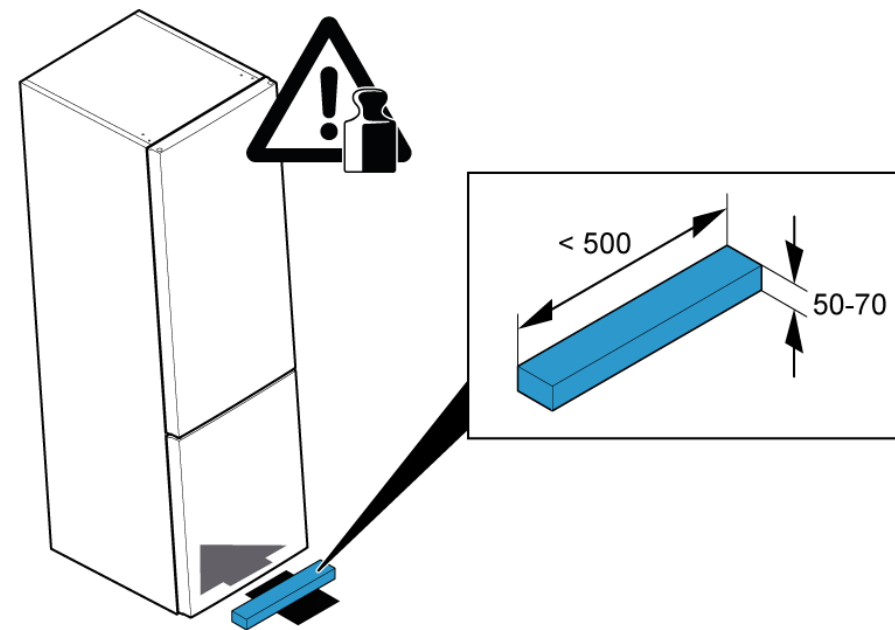

2.
 1. Свалете капачето на горната панта (1).
 2. Развийте двата винта (2).
 3. Свалете горната панта (3).

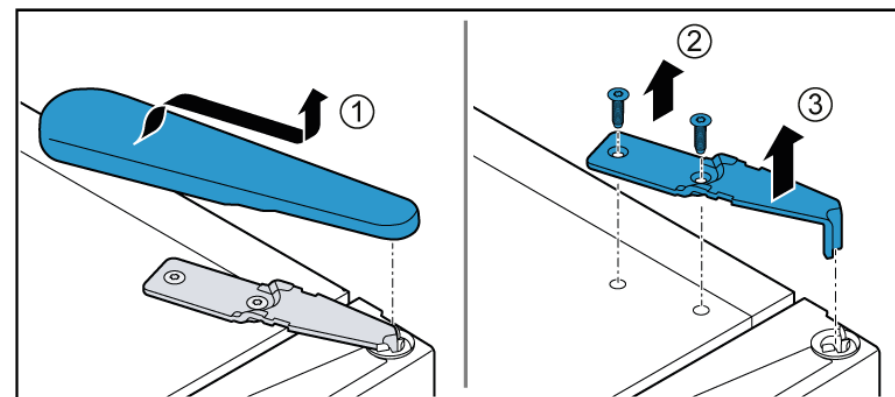

3. Свалете горната врата.

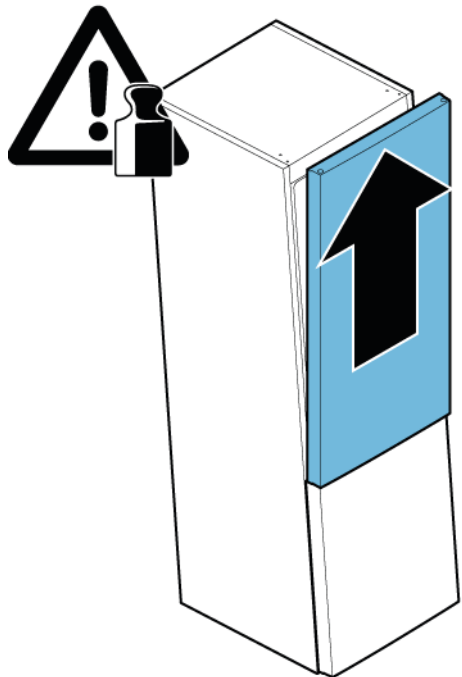

 Горната панта е отстранена.

4.3.2 Монтиране на горната панта на вратата

► Монтирайте в обратен ред.

4.4 Смяна на горната панта на вратата (врата с дисплей)

Специални инструменти:

 Накрайник Torx TX20 6,3 мм (1/4") [00340865]

	⚠ ПРЕДУПРЕЖДЕНИЕ
	<p>Тежки, обемисти уреди! Травми на гърба и мускулите</p> <ul style="list-style-type: none"> ▶ Операцията по отстраняване на вратите на уреда трябва да се извършва само от обучени специалисти. ▶ За преместването на уреда са необходими двама души. ▶ Използвайте само подходящи инструменти и оборудване.

	⚠ ВНИМАТЕЛНО
	<p>Остри ръбове! Наранявания от порязване</p> <ul style="list-style-type: none"> ▶ Носете предпазни ръкавици.

	⚠ ПРЕДУПРЕЖДЕНИЕ
	<p>Приплъзване на наклонени уреди! Костни фрактури/наранявания от премазване</p> <ul style="list-style-type: none"> ▶ Укрепете уредите срещу приплъзване.



	⚠ ВНИМАТЕЛНО
	<p>Риск от падащи части поради разхлабени винтове! Нараняване поради падащи части.</p> <ul style="list-style-type: none"> ▶ Закрепете компонента, така че да не падне.

	ВНИМАНИЕ!
	<p>Риск от падащи части поради разхлабени винтове! Повреда на други части на уреда или в дома на клиента, напр. дъното.</p> <ul style="list-style-type: none"> ▶ Закрепете компонента, така че да не падне.

	⚠ ОПАСНОСТ
	<p>Риск от токов удар поради части под напрежение! Опасност за живота от токов удар в случай на неправилен ремонт</p> <ul style="list-style-type: none"> ▶ Електрическите части трябва да се ремонтират от квалифицирани електротехници. ▶ След ремонта трябва да се извърши проверка за безопасност съгласно VDE 0701 или в съответствие със специфичните за страната разпоредби.

	⚠ ОПАСНОСТ
	<p>Риск от токов удар поради части под напрежение! Смърт от токов удар</p> <ul style="list-style-type: none"> ▶ Изключете уредите от електрическото захранване поне 60 секунди преди започване на ремонта.

Изискване:

-  Уредът е изключен от захранването.
-  Вътрешните фитинги на уреда са отстранени.

4.4.1 Сваляне на горната панта на вратата

1. Плъзнете опорна част под основната секция.

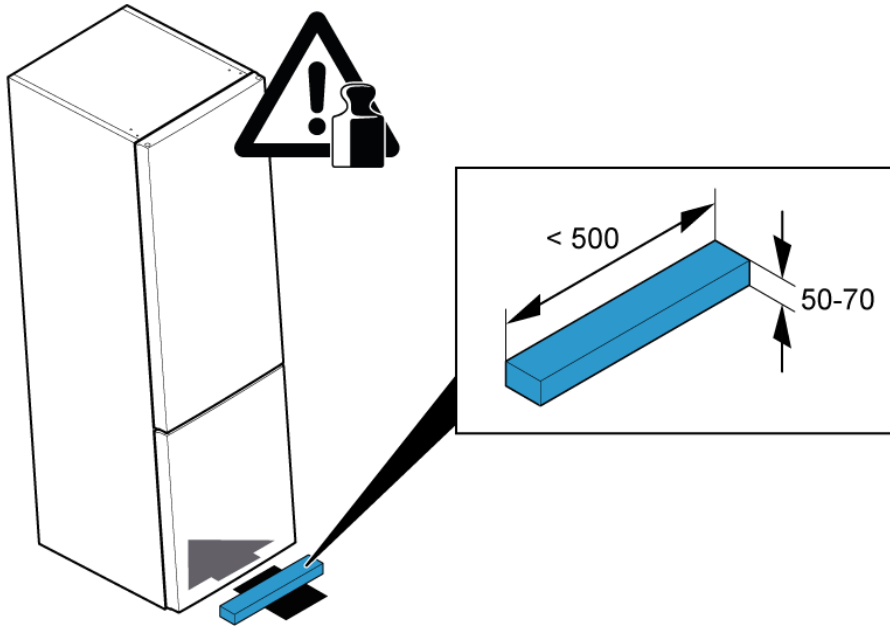

2.
 1. Свалете капачето на горната панта (1).
 2. Изключете електрическата връзка (2).
 3. Развийте винта за заземяващата връзка (3).

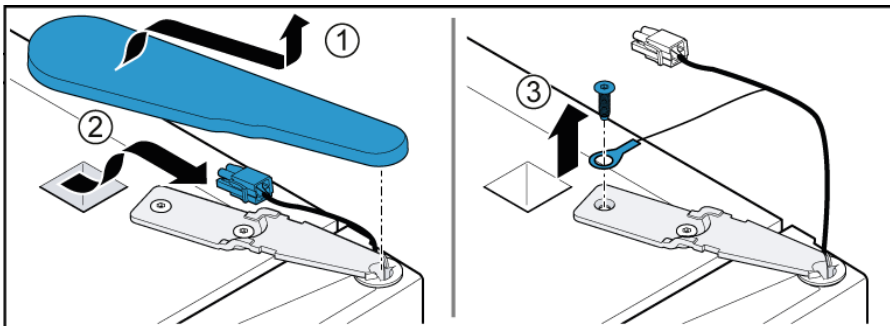

3.
 1. Развийте винта (1).
 2. Свалете горната панта (2).

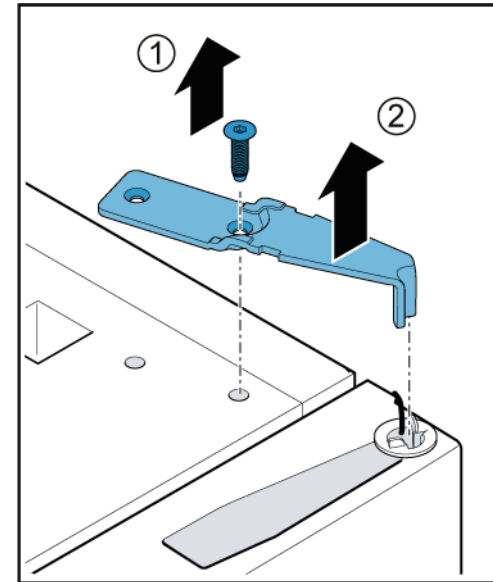

4. Свалете горната врата.

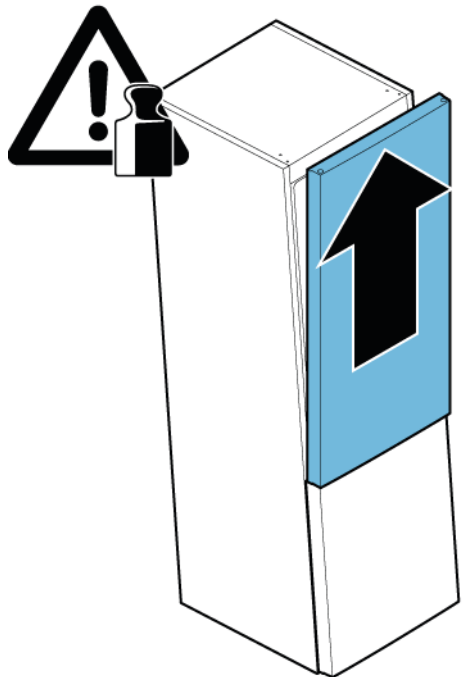

 Горната панта е отстранена.

4.4.2 Монтиране на горната панта на вратата

- ▶ Монтирайте в обратен ред.

4.5 Смяна на средната панта на вратата

Специални инструменти:

 Накрайник Torx TX20 6,3 мм (1/4") [00340865]

	<p style="text-align: center;">⚠ ПРЕДУПРЕЖДЕНИЕ</p> <p>Тежки, обемисти уреди! Травми на гърба и мускулите</p> <ul style="list-style-type: none"> ▶ Операцията по отстраняване на вратите на уреда трябва да се извършва само от обучени специалисти. ▶ За преместването на уреда са необходими двама души. ▶ Използвайте само подходящи инструменти и оборудване.
--	--



	<p style="text-align: center;">⚠ ВНИМАТЕЛНО</p> <p>Остри ръбове! Наранявания от порязване</p> <ul style="list-style-type: none"> ▶ Носете предпазни ръкавици.
--	--

	<p style="text-align: center;">⚠ ПРЕДУПРЕЖДЕНИЕ</p> <p>Приплъзване на наклонени уреди! Костни фрактури/наранявания от премазване</p> <ul style="list-style-type: none"> ▶ Укрепете уредите срещу приплъзване.
--	--

	<p style="text-align: center;">⚠ ВНИМАТЕЛНО</p> <p>Риск от падащи части поради разхлабени винтове! Нараняване поради падащи части.</p> <ul style="list-style-type: none"> ▶ Закрепете компонента, така че да не падне.
---	---

	<p style="text-align: center;">ВНИМАНИЕ!</p> <p>Риск от падащи части поради разхлабени винтове! Повреда на други части на уреда или в дома на клиента, напр. дъното.</p> <ul style="list-style-type: none"> ▶ Закрепете компонента, така че да не падне.
--	---

Изискване:

-  Уредът е изключен от захранването.
-  Вътрешните фитинги на уреда са отстранени.
-  Горната панта на вратата е свалена.

 Горната врата е отстранена.

4.5.1 Сваляне на средната панта на вратата

1. 1. Развийте двата винта (1).
2. Свалете средната панта (2).

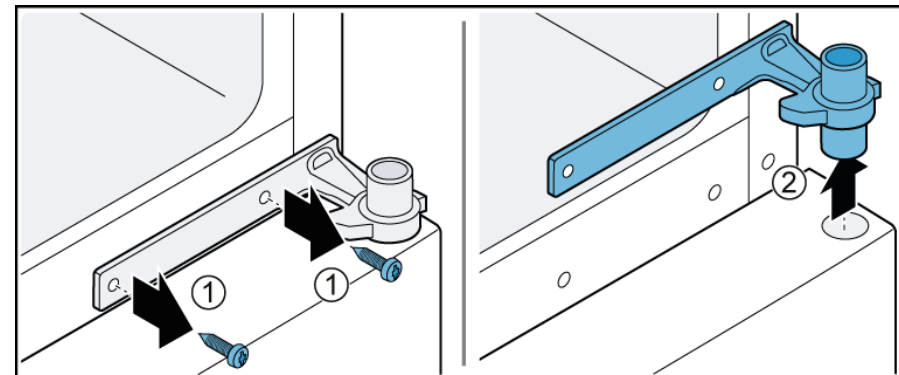

2. Свалете долната врата.

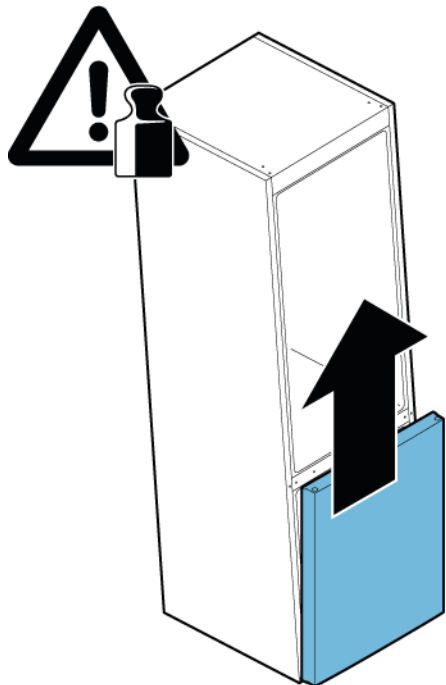

 Средната панта е свалена.

4.5.2 Монтиране на средната панта на вратата

► Монтирайте в обратен ред.

4.6 Смяна на долната панта на вратата

Специални инструменти:

 Накрайник Torx TX20 6,3 мм (1/4") [00340865]

	⚠ ПРЕДУПРЕЖДЕНИЕ
	<p>Тежки, обеимисти уреди! Травми на гърба и мускулите</p> <ul style="list-style-type: none"> ▶ Операцията по отстраняване на вратите на уреда трябва да се извършва само от обучени специалисти. ▶ За преместването на уреда са необходими двама души. ▶ Използвайте само подходящи инструменти и оборудване.



	⚠ ВНИМАТЕЛНО
	<p>Остри ръбове! Наранявания от порязване</p> <ul style="list-style-type: none"> ▶ Носете предпазни ръкавици.

	⚠ ПРЕДУПРЕЖДЕНИЕ
	<p>Приплъзване на наклонени уреди! Костни фрактури/наранявания от премазване</p> <ul style="list-style-type: none"> ▶ Укрепете уредите срещу приплъзване.

	⚠ ВНИМАТЕЛНО
	<p>Риск от падащи части поради разхлабени винтове! Нараняване поради падащи части.</p> <ul style="list-style-type: none"> ▶ Закрепете компонента, така че да не падне.

	ВНИМАНИЕ!
	<p>Риск от падащи части поради разхлабени винтове! Повреда на други части на уреда или в дома на клиента, напр. дъното.</p> <ul style="list-style-type: none"> ▶ Закрепете компонента, така че да не падне.

Изискване:

-  Уредът е изключен от захранването.
-  Вътрешните фитинги на уреда са отстранени.
-  Горната панта е свалена.

-  Средната панта е свалена.

4.6.1 Сваляне на долната панта на вратата

- ▶ 1. Развийте двата винта (1).
- ▶ 2. Свалете долната панта (2).

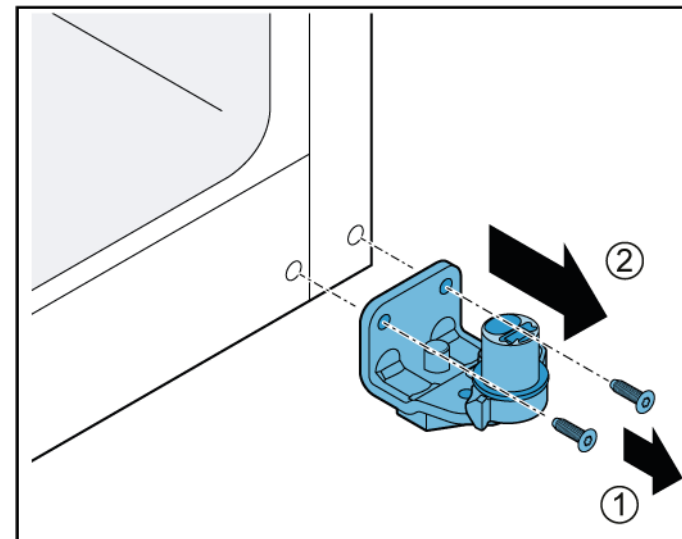

-  Долната панта на вратата е свалена.

4.6.2 Монтиране на долната панта на вратата

- ▶ Монтирайте в обратен ред.

4.7 Смяна на рафта

Изискване:

- ✔ Вратата е отворена.

4.7.1 Изваждане на рафта

- ▶ 1. Повдигнете лавицата в задната част (1).
- ▶ 2. Освободете лавицата (2).

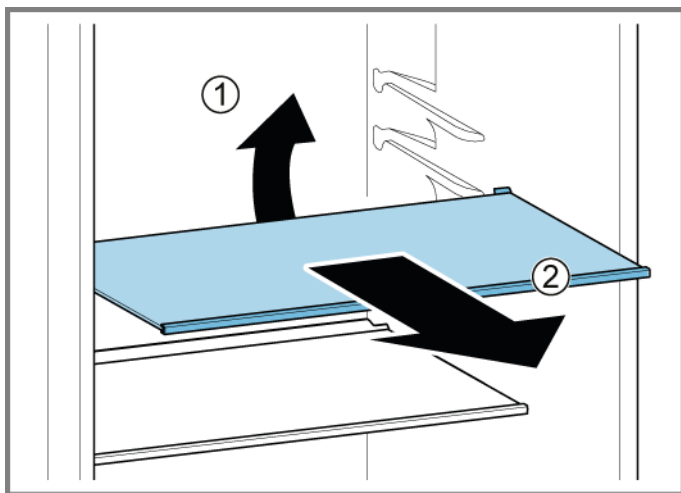

- ➡ Лавицата е отстранена.

4.7.2 Монтиране на рафта

- ▶ Монтирайте в обратен ред.

4.8 Смяна на табличката за бутилки

Изискване:

- ✔ Вратата е отворена.

4.8.1 Сваляне на табличката за бутилки

- ▶ Издърпайте табличката за бутилки.

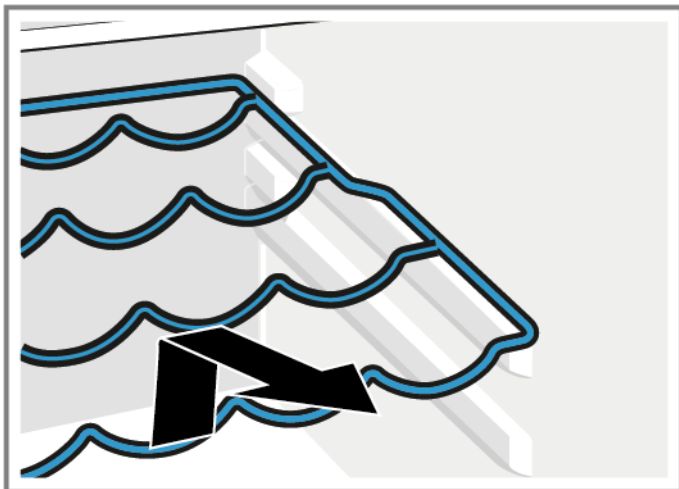

- ➡ Табличката за бутилки е свалена.

4.8.2 Монтиране на табличката за бутилки

- ▶ Монтирайте в обратен ред.

4.9 Смяна на стелажа на вратата

Изискване:

- ✔ Вратата е отворена.

4.9.1 Изваждане на стелажа на вратата

- ▶ Повдигнете стелажа на вратата нагоре.

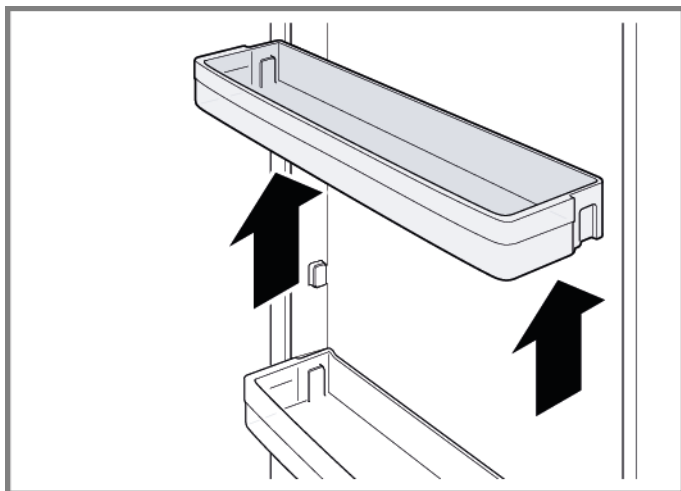

- ➡ Стелажът на вратата е свален.

4.9.2 Монтиране на стелажа на вратата

- ▶ Монтирайте в обратен ред.

4.10 Смяна на контейнера за съхранение

Изискване:

- ✔ Вратата е отворена.

4.10.1 Отстраняване на контейнера за съхранение

1. Издърпайте контейнера за съхранение докъдето може да стигне.
2. 1. Повдигнете контейнера в предната част (1).
2. Извадете контейнера (2).

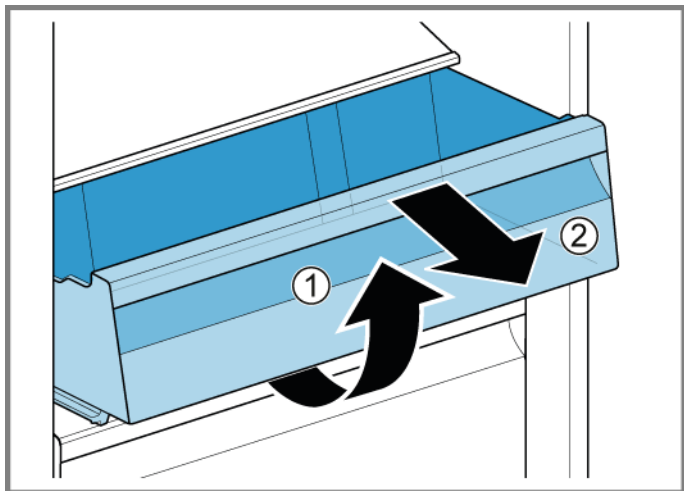

- ➔ Контейнерът за съхранение е отстранен.

4.10.2 Поставяне на контейнера за съхранение

- ▶ Монтирайте в обратен ред.

4.11 Смяна на контейнера за плодове и зеленчуци

Изискване:

- ✔ Вратата е отворена.

4.11.1 Изваждане на контейнера за плодове и зеленчуци

1. Издърпайте контейнера за плодове и зеленчуци докъдето може да стигне.
2. 1. Повдигнете контейнера за плодове и зеленчуци в предната част (1).
2. Извадете контейнера (2).

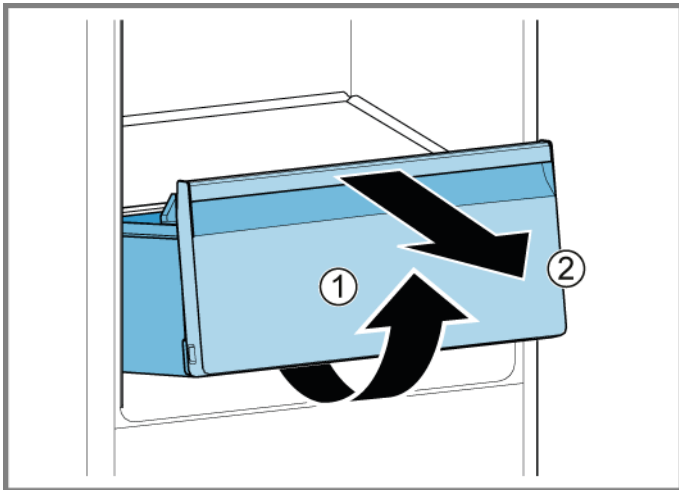

- ➡ Контейнерът за плодове и зеленчуци е отстранен.

4.11.2 Монтиране на контейнера за плодове и зеленчуци

- ▶ Монтирайте в обратен ред.

4.12 Смяна на лавицата над контейнера за плодове и зеленчуци

Изискване:

- ✓ Вратата е отворена.
- ✓ [Контейнерът за плодове и зеленчуци е отстранен.](#)→23

4.12.1 Отстраняване на лавицата над контейнера за плодове и зеленчуци

1. Натиснете уплътнителната рамка нагоре и навън.

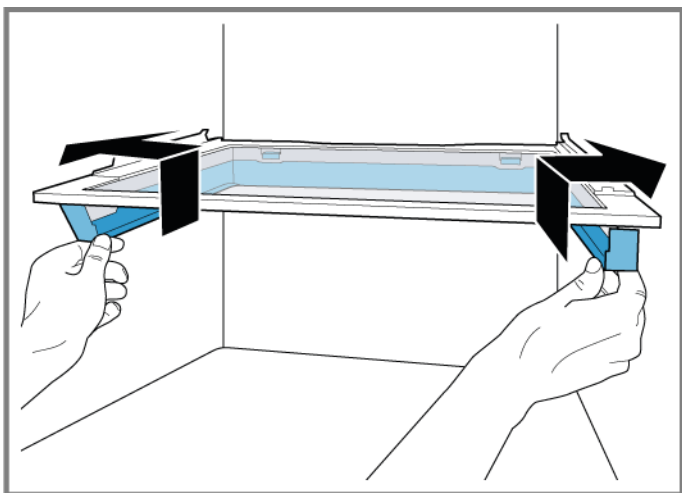

- ➡ Страничните куки се освобождават.

2. Повдигнете уплътнителната рамка и я плъзнете назад.

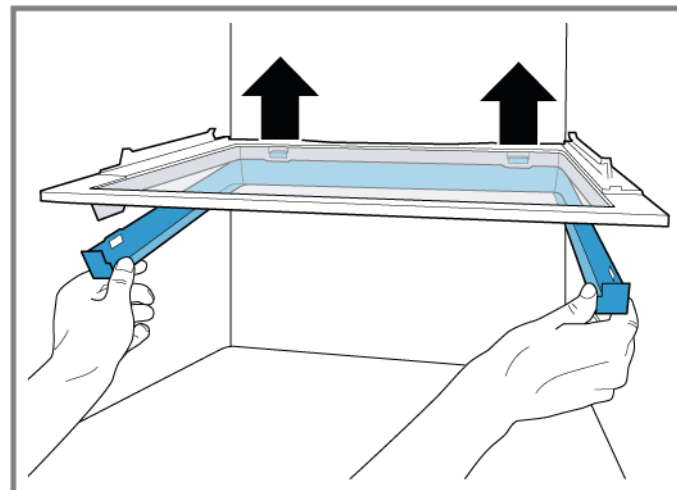

- ➡ Задните куки са освободени.

3. Отстранете уплътнителната рамка.

4. Повдигнете нагоре лавицата над контейнера за плодове и зеленчуци и я завъртете навън от едната страна.

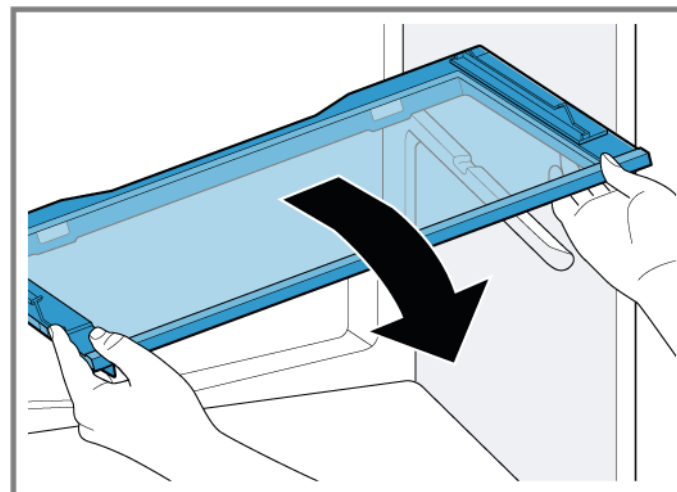

- ➡ Лавицата над контейнера за плодове и зеленчуци е отстранена.

4.12.2 Поставяне на лавицата над контейнера за плодове и зеленчуци

- ▶ Монтирайте в обратен ред.

4.13 Смяна на контейнера за замразени хранителни продукти

Изискване:

- ✔ Вратата е отворена.

4.13.1 Изваждане на контейнера за замразени хранителни продукти

- ▶ 1. Издърпайте докрай контейнера за замразени хранителни продукти (1).
- ▶ 2. Извадете контейнера за хранителни продукти (2).

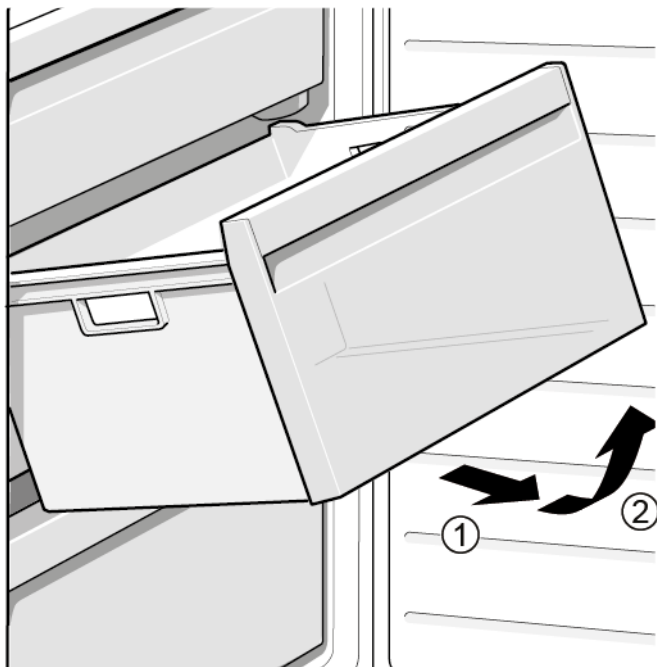

- ➡ Контейнерът за замразени хранителни продукти е изваден.

4.13.2 Монтиране на контейнера за замразени хранителни продукти

- ▶ Монтирайте в обратен ред.

4.14 Смяна на горната LED лампа

Специални инструменти:

 Специален инструмент

[00342180]



Вашият уред е снабден с LED осветление, което не изисква поддръжка.

Това осветление може да бъде ремонтирано само от специалисти от службата за обслужване на клиенти или от квалифицирани техници!



ОПАСНОСТ

Риск от токов удар поради части под напрежение!

Опасност за живота от токов удар в случай на неправилен ремонт

- ▶ Електрическите части трябва да се ремонтират от квалифицирани електротехници.
- ▶ След ремонта трябва да се извърши проверка за безопасност съгласно VDE 0701 или в съответствие със специфичните за страната разпоредби.



ОПАСНОСТ

Риск от токов удар поради части под напрежение!

Смърт от токов удар

- ▶ Изключете уредите от електрическото захранване поне 60 секунди преди започване на ремонта.





ВНИМАТЕЛНО

Остри ръбове!

Наранявания от порязване

- ▶ Носете предпазни ръкавици.

Изискване:

-  Уредът е изключен от захранването.
-  Вратата е отворена.

4.14.1 Отстраняване на горната LED лампа

1. 1. Плъзнете инструмент за разделяне между горната LED лампа и вътрешната облицовка на отделението на хладилника, за да освободите кукиите на лампата (1).
2. Отстранете горната LED лампа (2).

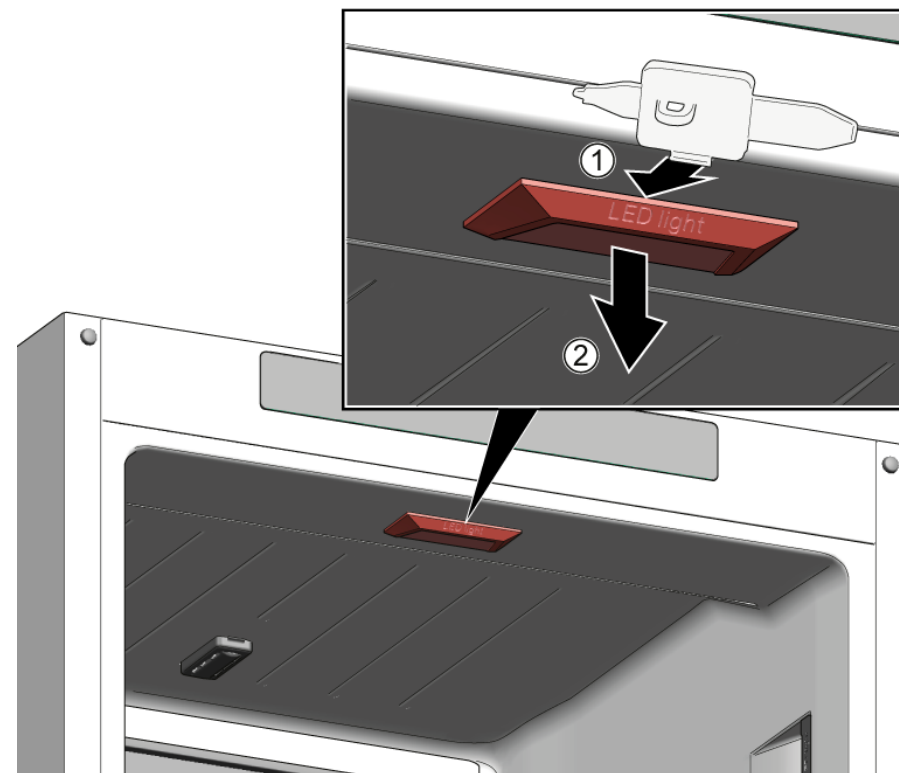

2. Разкачете електрическата връзка на горната LED лампа.
-  Горната LED лампа е отстранена.

4.14.2 Поставяне на горната LED лампа

- ▶ Монтирайте в обратен ред.

4.15 Смяна на страничната LED лампа



Специални инструменти:



 Специален инструмент

[00342180]

	<p>Вашият уред е снабден с LED осветление, което не изисква поддръжка.</p> <p>Това осветление може да бъде ремонтирано само от специалисти от службата за обслужване на клиенти или от квалифицирани техници!</p>
---	---



	<p style="text-align: center;"> ОПАСНОСТ</p> <p>Риск от токов удар поради части под напрежение!</p> <p>Опасност за живота от токов удар в случай на неправилен ремонт</p> <ul style="list-style-type: none"> ▶ Електрическите части трябва да се ремонтират от квалифицирани електротехници. ▶ След ремонта трябва да се извърши проверка за безопасност съгласно VDE 0701 или в съответствие със специфичните за страната разпоредби.
--	---

	<p style="text-align: center;"> ОПАСНОСТ</p> <p>Риск от токов удар поради части под напрежение!</p> <p>Смърт от токов удар</p> <ul style="list-style-type: none"> ▶ Изключете уредите от електрическото захранване поне 60 секунди преди започване на ремонта.
--	--

	<p style="text-align: center;"> ВНИМАТЕЛНО</p> <p>Остри ръбове!</p> <p>Наранявания от порязване</p> <ul style="list-style-type: none"> ▶ Носете предпазни ръкавици.
--	---

	<p style="text-align: center;">ВНИМАНИЕ!</p> <p>Риск от повреда на електростатично чувствителни компоненти (ESD)!</p> <p>Повреда на компоненти</p> <ul style="list-style-type: none"> ▶ Преди да докоснете електростатично чувствителни компоненти, използвайте електростатична защитна система (лента за ръка със заземителен куплунг). ▶ Не докосвайте връзките и проводникови пътища на модулите. ▶ Транспортирайте ESD компоненти само в проводящи материали или оригинални опаковки. ▶ Дръжте ESD компонентите далеч от електростатично зареждащи се материали (напр. пластмаса).
---	--

Изискване:

-  Уредът е изключен от захранването.
-  Вратата е отворена.
-  Вътрешните RC фитинги са отстранени.

4.15.1 Отстраняване на страничната LED лампа

1. 1. Плъзнете инструмент за разделяне между дифузера и корпуса на лампата, за да освободите кукичката (1).
2. Извадете дифузера на лампата (2).
3. Освободете следващите кукички за фиксиране на дифузера по същия начин.

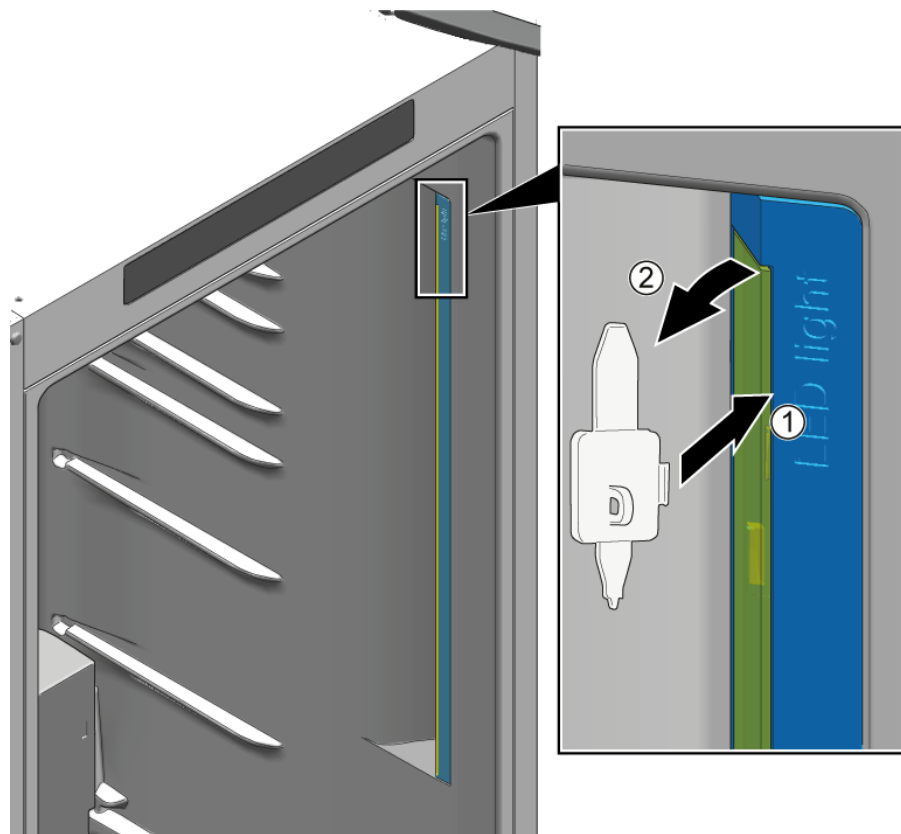

 Дифузерът на лампата е отстранен.

2. 1. Натиснете кукичката за фиксиране, за да я освободите (1).
2. Преместете модула на светодиода на около 1 см, за да го разедините от електрическото гнездо (2).
3. Отстранете LED модула (3).

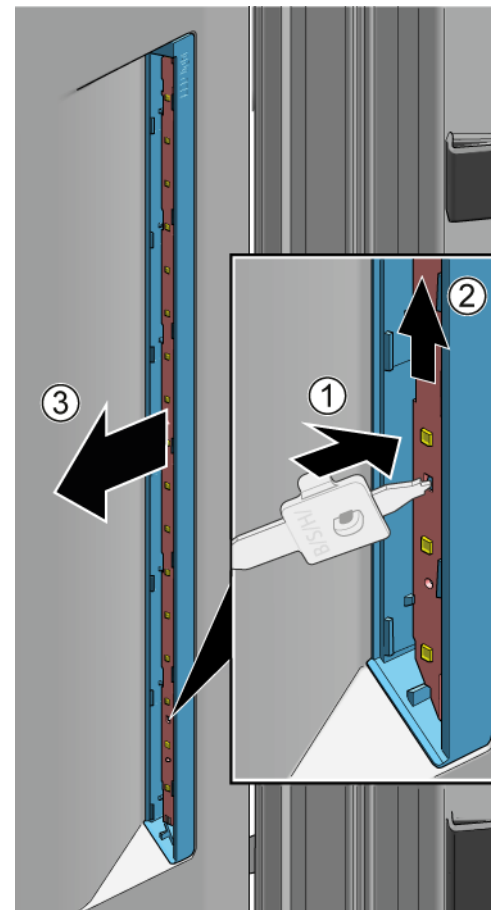

 Страничната LED лампа е отстранена.

4.15.2 Поставяне на страничната LED лампа



Поради възможността кукичките на дифузера на лампата да се счупят по време на процеса на отстраняване, резервната странична LED лампа е комплект, който включва LED модул и дифузер на лампата.

1. Плъзнете инструмент за разделяне между дифузера и корпуса на лампата, за да освободите кукичката (1).
2. Извадете дифузера на лампата (2).
3. Освободете следващите кукички за фиксиране на дифузера по същия начин.

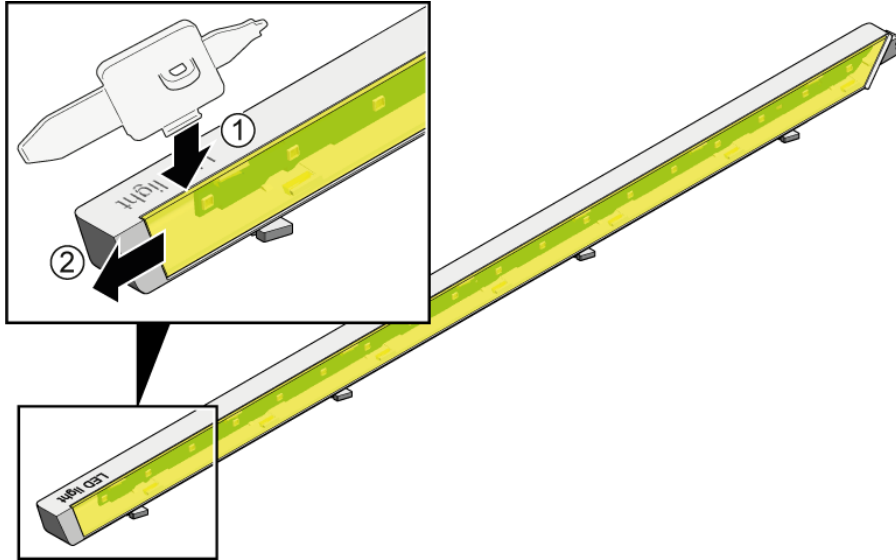

2. 1. Натиснете кукичката за фиксиране, за да я освободите (1).
2. Плъзнете LED модула навън от корпуса.
3. Поставете корпуса на LED модула в торба, която се използва поради съображения за безопасност при транспортиране на резервни части (3).

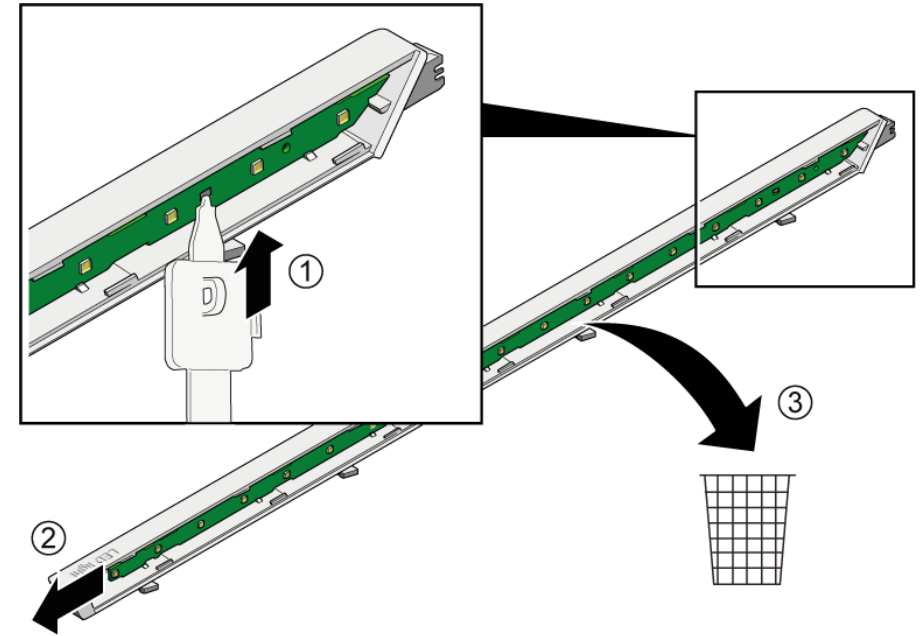

3. Монтирайте LED модула и дифузера на лампата в обратен ред на отстраняването.

4.16 Смяна на LED лампата на фризера

Специални инструменти:

 Специален инструмент [00342180]



	<p>Вашият уред е снабден с LED осветление, което не изисква поддръжка.</p> <p>Това осветление може да бъде ремонтирано само от специалисти от службата за обслужване на клиенти или от квалифицирани техници!</p>
---	---

	<p style="text-align: center;">⚠ ОПАСНОСТ</p> <p>Риск от токов удар поради части под напрежение! Опасност за живота от токов удар в случай на неправилен ремонт</p> <ul style="list-style-type: none"> ▶ Електрическите части трябва да се ремонтират от квалифицирани електротехници. ▶ След ремонта трябва да се извърши проверка за безопасност съгласно VDE 0701 или в съответствие със специфичните за страната разпоредби.
--	--

	<p style="text-align: center;">⚠ ОПАСНОСТ</p> <p>Риск от токов удар поради части под напрежение! Смърт от токов удар</p> <ul style="list-style-type: none"> ▶ Изключете уредите от електрическото захранване поне 60 секунди преди започване на ремонта.
--	---

	<p style="text-align: center;">⚠ ВНИМАТЕЛНО</p> <p>Остри ръбове! Наранявания от порязване</p> <ul style="list-style-type: none"> ▶ Носете предпазни ръкавици.
--	--



Изискване:

-  Уредът е изключен от захранването.
-  Вратата е отворена.

4.16.1 Отстраняване на LED лампата на фризера

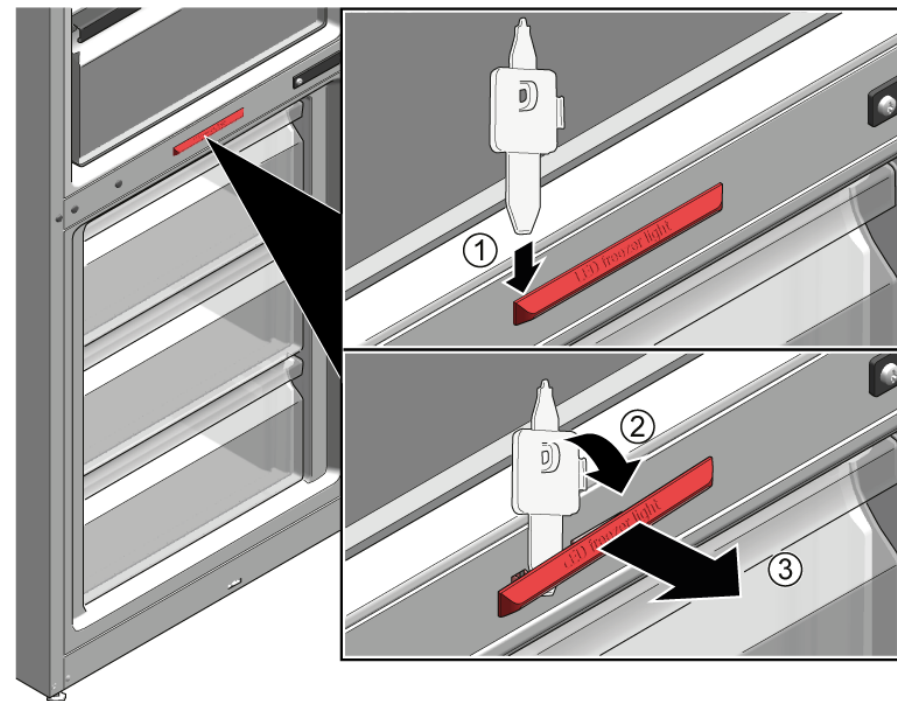
- ▶ 1. Плъзнете инструмент за разделяне между и корпуса от страни на лампата, за да създадете пролука (1).
- ▶ 2. Плъзнете инструмент за разделяне от другата страна на куката за фиксиране на лампата и я завъртете напред (2).
- ▶ 3. Отстранете LED лампата на фризера (3).







-  LED лампата на фризера е разкачена.
-  LED лампата на фризера е отстранена.

4.16.2 Поставяне на LED лампата на фризера

- ▶ Монтирайте в обратен ред.

Savjeti za popravak - Kombinacija hladnjak/zamrzivač

 O ovom dokumentu	33	4.8 Zamjena police za boce.....	50
1.1 Važne informacije.....	33	4.8.1 Uklanjanje police za boce.....	50
1.1.1 Svrha.....	33	4.8.2 Postavljanje police za boce.....	50
1.2 Objašnjenje oznaka.....	33	4.9 Zamjena posude za vrata.....	51
1.2.1 Stupnjevi opasnosti.....	33	4.9.1 Uklanjanje posude za vrata.....	51
1.2.2 Oznake opasnosti.....	33	4.9.2 Postavljanje posude za vrata.....	51
1.2.3 Struktura upozorenja.....	34	4.10 Zamjena spremnika.....	52
1.2.4 Opće oznake.....	34	4.10.1 Uklanjanje spremnika.....	52
 Sigurnost	35	4.10.2 Ugradnja spremnika.....	52
2.1 Opće sigurnosne upute.....	35	4.11 Zamjena spremnika za voće i povrće.....	53
2.1.1 Svi kućanski uređaji.....	35	4.11.1 Uklanjanje spremnika za voće i povrće.....	53
 Alat i pomagala	36	4.11.2 Postavljanje spremnika za voće i povrće.....	53
 Popravak	37	4.12 Zamjena police iznad spremnika za voće i povrće.....	54
4.1 Zamjena brtve vrata.....	37	4.12.1 Uklanjanje police iznad spremnika za voće i povrće.....	54
4.1.1 Uklanjanje brtve vrata.....	37	4.12.2 Ugradnja police iznad spremnika za voće i povrće.....	55
4.1.2 Postavljanje brtve vrata.....	37	4.13 Zamjena spremnika za zamrznute namirnice.....	56
4.2 Zamjena ručke za vrata.....	40	4.13.1 Uklanjanje spremnika za zamrznute namirnice.....	56
4.2.1 Uklanjanje ručke za vrata.....	40	4.13.2 Postavljanje spremnika za zamrznute namirnice.....	56
4.2.2 Postavljanje ručke za vrata.....	40	4.14 Zamjena gornje LED svjetiljke.....	57
4.3 Zamjena gornjeg zgloba vrata.....	41	4.14.1 Uklanjanje gornje LED svjetiljke.....	57
4.3.1 Uklanjanje gornjeg zgloba vrata.....	41	4.14.2 Ugradnja gornje LED svjetiljke.....	57
4.3.2 Postavljanje gornjeg zgloba vrata.....	42	4.15 Zamjena bočne LED svjetiljke.....	58
4.4 Zamjena gornjeg zgloba vrata (vrata sa zaslonom).....	43	4.15.1 Uklanjanje bočne LED svjetiljke.....	58
4.4.1 Uklanjanje gornjeg zgloba vrata.....	44	4.15.2 Ugradnja bočne LED svjetiljke.....	59
4.4.2 Postavljanje gornjeg zgloba vrata.....	45	4.16 Zamjena LED svjetiljke zamrzivača.....	61
4.5 Zamjena srednjeg zgloba vrata.....	46	4.16.1 Uklanjanje LED svjetiljke zamrzivača.....	61
4.5.1 Uklanjanje srednjeg zgloba vrata.....	46	4.16.2 Ugradnja LED svjetiljke zamrzivača.....	61
4.5.2 Postavljanje srednjeg zgloba vrata.....	47		
4.6 Zamjena donjeg zgloba vrata.....	48		
4.6.1 Uklanjanje donjeg zgloba vrata.....	48		
4.6.2 Postavljanje donjeg zgloba vrata.....	48		
4.7 Zamjena police.....	49		
4.7.1 Uklanjanje police.....	49		
4.7.2 Postavljanje police.....	49		

i O ovom dokumentu

1.1 Važne informacije

1.1.1 Svrha

Ove upute za popravak služe kao podrška korisnicima prilikom samostalnog popravljivanja uređaja u skladu s primjenjivom Direktivom o ekološkom dizajnu (od ožujka 2021.).

One sadrže informacije o zamjeni određenih rezervnih dijelova, kao i napomene o upozorenjima i opasnostima.

Ako imate dodatna pitanja, obratite se našoj službi za korisnike. Mi snosimo odgovornost za oštećenja samo u slučaju pridržavanja uputa za popravak.

1.2 Objašnjenje oznaka

1.2.1 Stupnjevi opasnosti

Stupnjevi upozorenja sastoje se od oznake i signalne riječi. Signalna riječ ukazuje na ozbiljnost opasnosti.





Stupanj upozorenja	Značenje
 OPASNOST	Nepridržavanje poruke upozorenja rezultirat će smrtnim ili teškim ozljedama.
 UPOZORENJE	Nepridržavanje poruke upozorenja može rezultirati smrtnim ili teškim ozljedama.
 OPREZ	Nepridržavanje poruke upozorenja može rezultirati lakšim ozljedama.
 POZORI!	Nepridržavanje poruke upozorenja može rezultirati oštećenjem imovine.

Tablica 1: Stupnjevi opasnosti



1.2.2 Oznake opasnosti

Oznake opasnosti simbolička su reprezentacija s oznakom vrste opasnosti.

U ovom dokumentu koriste se sljedeće oznake opasnosti:

Oznaka opasnosti	Značenje
	Opća poruka upozorenja
	Opasnost od električnog napona
	Opasnost od eksplozije
	Opasnost od porezotina
	Opasnost od prignječenja

O ovom dokumentu

Oznaka opasnosti	Značenje
	Opasnost od vrućih površina
	Opasnost od jakog magnetskog polja
	Opasnost od neionizirajućeg zračenja

Tablica 2: Oznake opasnosti

1.2.3 Struktura upozorenja

Upozorenja u ovom dokumentu imaju normirani izgled i strukturu.



	<div style="background-color: red; color: white; padding: 2px; text-align: center;"> OPASNOST</div> <p>Vrsta i izvor opasnosti! Moguće posljedice zanemarivanja opasnosti/upozorenja.</p> <ul style="list-style-type: none"> ▶ Mjere i zabrane za sprječavanje opasnosti.
--	---





Sljedeći primjer pokazuje upozorenje na strujni udar od dijelova koji provode struju. Spominje se mjera za izbjegavanje opasnosti.

	<div style="background-color: red; color: white; padding: 2px; text-align: center;"> OPASNOST</div> <p>Opasnost od strujnog udara zbog dijelova koji provode struju! Smrt od strujnog udara</p> <ul style="list-style-type: none"> ▶ Isključite uređaj iz električnog napajanja najmanje 60 sekundi prije izvođenja popravaka.
---	--

1.2.4 Opće oznake

U ovom dokumentu koriste se sljedeće opće oznake:

Opća znaka	Značenje
	Oznaka posebnog savjeta (tekst i/ili grafika)
	Oznaka jednostavnog savjeta (samo tekst)
	Oznaka veze na videovodič

Opća znaka	Značenje
	Oznaka potrebnog alata
	Oznaka potrebnih preduvjeta
	Oznaka uvjeta (ako ..., tad ...)
	Oznaka rezultata
[Početak]	Oznaka tipke ili gumba
[00123456]	Oznaka broja materijala
Status	Oznaka prikazanog teksta / prozor (na zaslonu uređaja)

Tablica 3: Opće oznake

2.1 Opće sigurnosne upute

2.1.1 Svi kućanski uređaji

Opasnost od strujnog udara zbog dijelova koji provode struju!

- Pogreške izazvane popravcima električnih sastavnih dijelova mogu dovesti do strujnog udara!
- Isključite uređaj iz struje na najmanje 60 sekundi prije početka radova.
- Nakon popravka provedite sigurnosni test u skladu s VDE 0701 ili nacionalnim propisima.

Opasnost od ozljeda zbog oštih rubova!

- Nosite zaštitne rukavice.

Opasnost od prignječenja tijekom izvođenja radova na popravcima, održavanju, rješavanju problema i servisiranju teških i pokretnih sastavnih dijelova

- Nosite zaštitnu obuću.
- Osigurajte teške sastavne dijelove od pada.
- Nemojte umetati dijelove tijela u pokretne sastavne dijelove.

Opasnost za sigurnost/rad uređaja!

- Koristite samo originalne rezervne dijelove.

Opasnost od oštećenja elektrostatički osjetljivih sastavnih dijelova (ESD)!

- Nemojte dodirivati module, uključujući priključke i rute vodiča.

Alat i pomagala

Oznaka	Pojedinosti	Slike
Nastavak Torx TX20 [00340865]	6,3 mm (1/4")	
Specijalni alat [00342180]		

4.1 Zamjena brtve vrata

Zahtjev:

-  Vrata su otvorena.

4.1.1 Uklanjanje brtve vrata

1. Otpustite brtvu vrata iz utora u desnom i lijevom kutu.

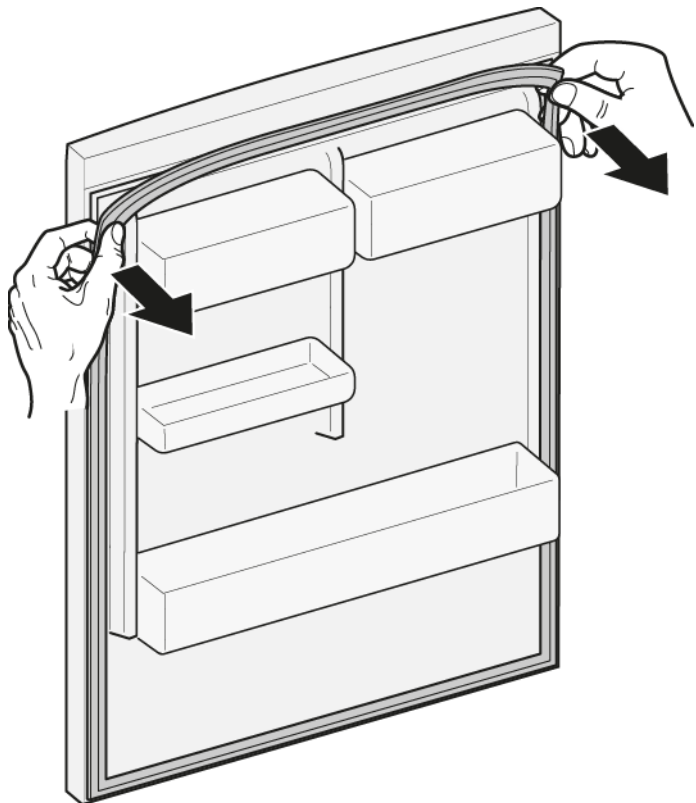

2. Izvucite brtvu vrata iz utora.



-  Brtva vrata je uklonjena.

4.1.2 Postavljanje brtve vrata



Debljina nove brtve vrata može malo odstupati od debljine stare brtve vrata. To neće utjecati na zatvaranje i dugoročnu funkciju.

Ako uređaj ima prilagodljive zglobove ili nastavke zglobova, možete dodatno optimizirati zatvaranje.

Mali bočni otvori u brtvi vrata su funkcijski (potrebni za ventilaciju). Nije riječ o proizvodnim pogreškama.

1. Provjerite ima li oštećenja na utoru za brtvu.

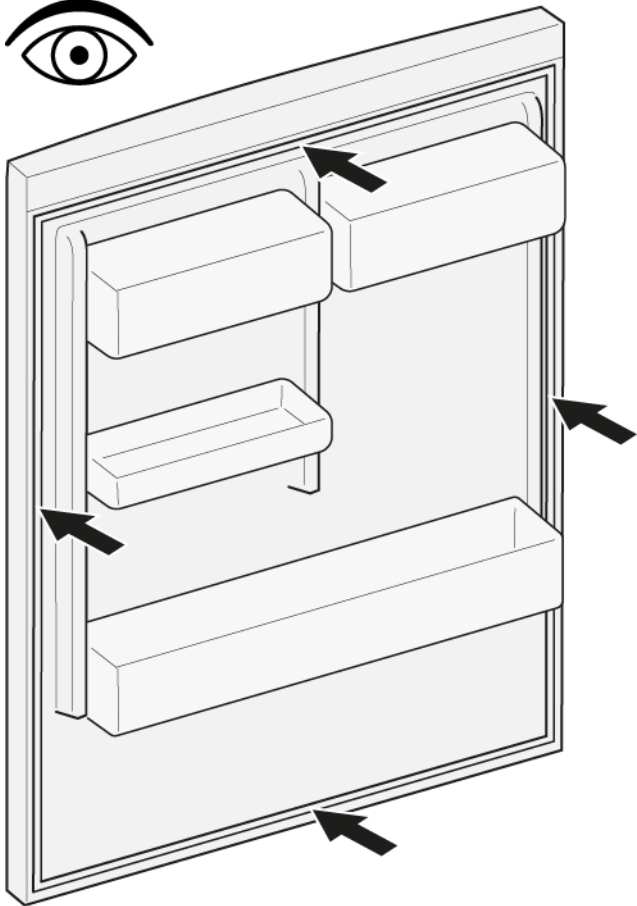

4. Gurnite kutove brtve na vrh i dno utora.

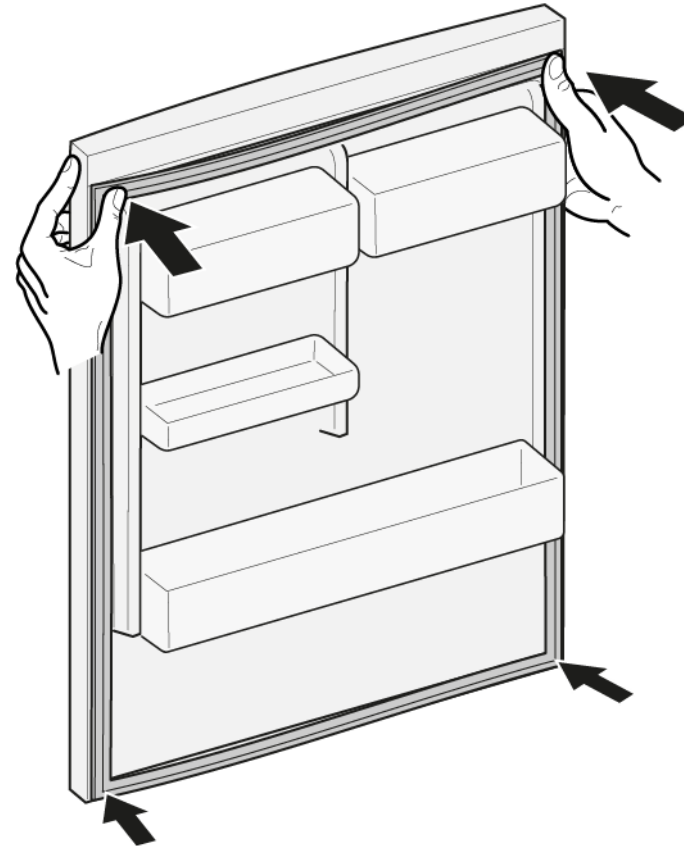

2.  Ako je utor za brtvu oštećen.
- Obratite se službi za korisnike.

3.  Blago odstupanje brtve vrata normalno je i ne utječe na funkciju. Preporučuje se izravnati brtvu vrata prije umetanja u uređaj.

Zagrijte brtvu vrata sušilom za kosu ili vrućom vodom i ručno je oblikujte.

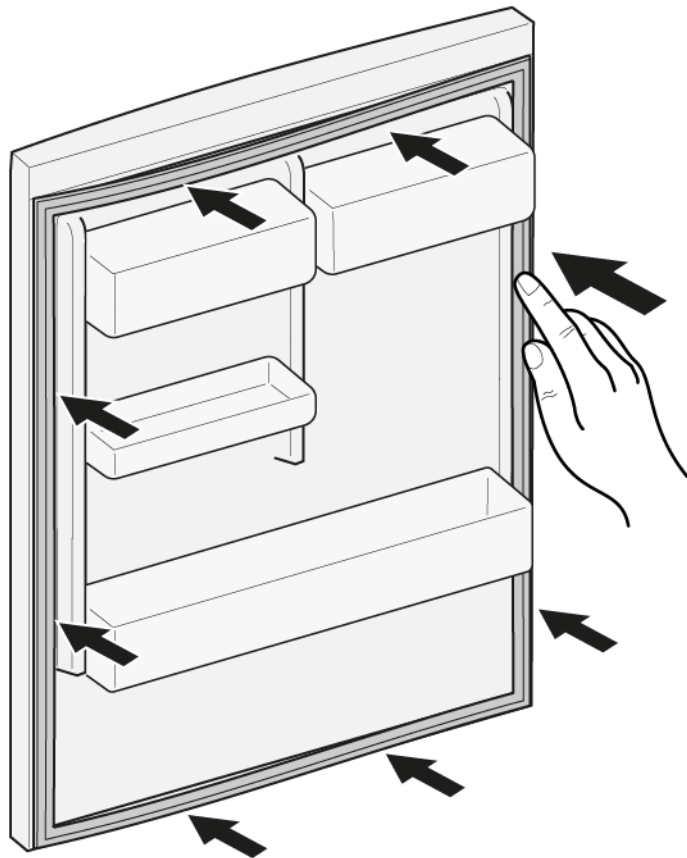

5. Utisnite cijelu brtvu korak po korak u utor.





 Brtva vrata je postavljena.

4.2 Zamjena ručke za vrata

Specijalni alati:

-  Nastavak Torx TX20 6,3 mm (1/4") [00340865]
-  Odvijač s utorom Nož 10 mm x 1,6 mm x 200 mm

Zahtjev:

-  Uređaj je isključen iz napajanja.
-  Vrata su otvorena.

4.2.1 Uklanjanje ručke za vrata

- ▶ 1. Uklonite dva navojna čepa (1).
- ▶ 2. Odvijte dva vijka (2).
- ▶ 3. Uklonite ručku za vrata (3).

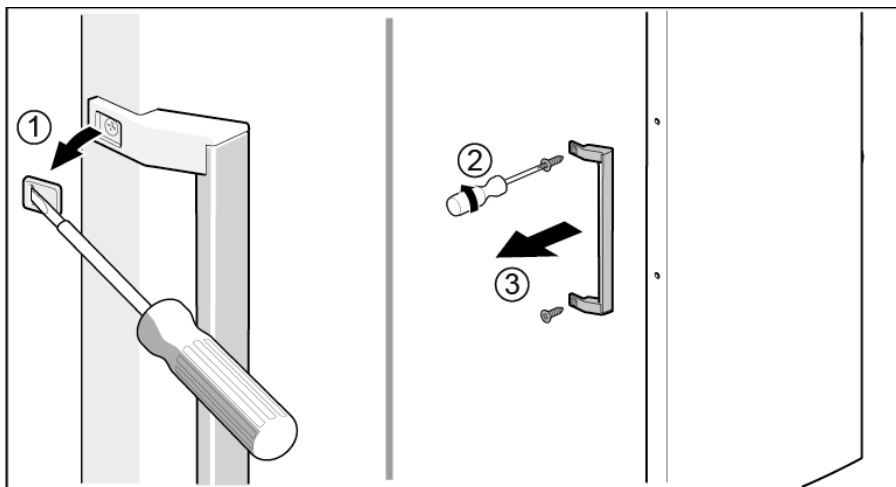

-  Ručka za vrata je uklonjena.



Ručka za druga vrata može se ukloniti na isti način.

4.2.2 Postavljanje ručke za vrata

- ▶ Postavite obratnim redoslijedom.

4.3 Zamjena gornjeg zgloba vrata

Specijalni alati:

🌀 Nastavak Torx TX20 6,3 mm (1/4") [00340865]

	⚠️ UPOZORENJE
	<p>Teški, veliki uređaji! Ozljede leđa i kralježnice</p> <ul style="list-style-type: none"> ▶ Uklanjanje vrata uređaja smiju obavljati samo obučeni stručnjaci. ▶ Za pomicanje uređaja potrebne su dvije osobe. ▶ Koristite samo prikladan alat i opremu.

	⚠️ OPREZ
	<p>Oštri rubovi! Porezotine</p> <ul style="list-style-type: none"> ▶ Nosite zaštitne rukavice.

	⚠️ UPOZORENJE
	<p>Isklizavanje nagnutih uređaja! Puknuća kostiju / ozljede od prignječenja</p> <ul style="list-style-type: none"> ▶ Osigurajte uređaje od isklizavanja.

	⚠️ OPREZ
	<p>Opasnost od padanja dijelova zbog otpuštenih vijaka! Ozljeda od dijelova koji padaju.</p> <ul style="list-style-type: none"> ▶ Osigurajte sastavne dijelove od pada.

	POZOR!
	<p>Opasnost od padanja dijelova zbog otpuštenih vijaka! Oštećenje drugih dijelova uređaja ili objekta klijenta, npr. poda.</p> <ul style="list-style-type: none"> ▶ Osigurajte sastavne dijelove od pada.

Zahtjev:

- ✅ Uređaj je isključen iz napajanja.
- ✅ Unutarnja oprema uređaja je uklonjena.

4.3.1 Uklanjanje gornjeg zgloba vrata

1. Gurnite potporni dio pod bazu.

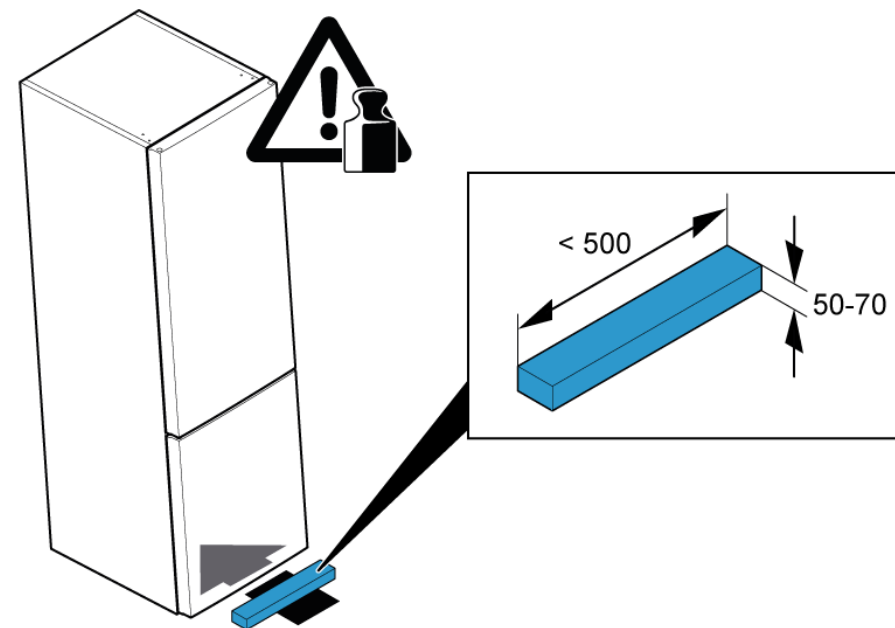

2. 1. Skinite poklopac gornjeg zgloba (1).
2. Odvijte dva vijka (2).
3. Skinite gornji zglob (3).

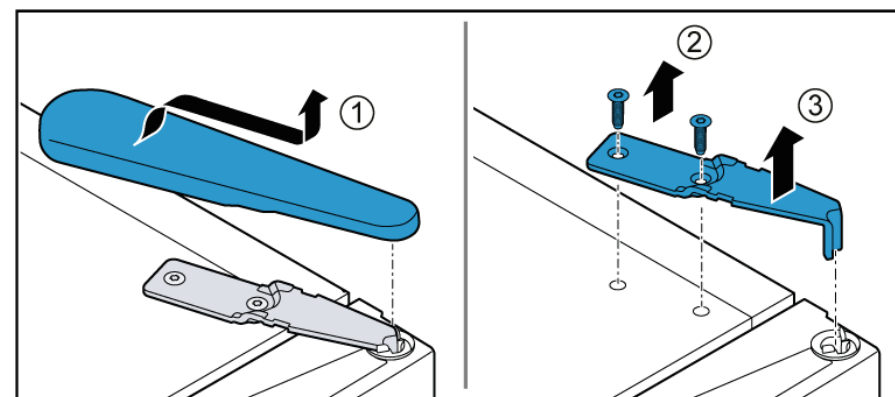

3. Skinite gornja vrata.

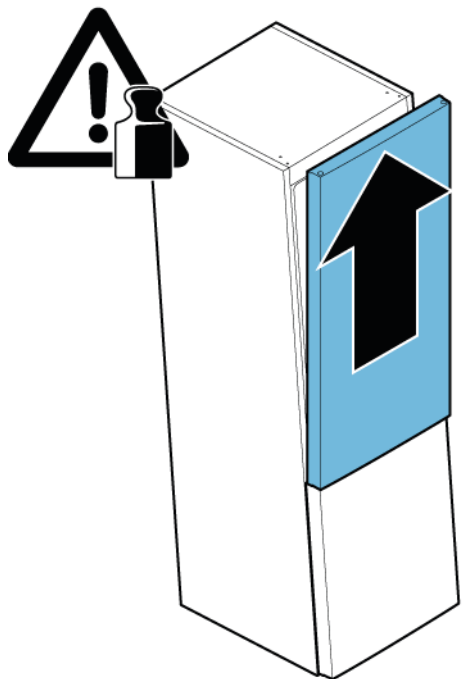

➡ Gornji je zglob skinut.

4.3.2 Postavljanje gornjeg zgloba vrata

- ▶ Postavite obratnim redoslijedom.

4.4 Zamjena gornjeg zgloba vrata (vrata sa zaslonom)

Specijalni alati:

 Nastavak Torx TX20 6,3 mm (1/4") [00340865]

	⚠ UPOZORENJE
	<p>Teški, veliki uređaji! Ozljede leđa i kralježnice</p> <ul style="list-style-type: none"> ▶ Uklanjanje vrata uređaja smiju obavljati samo obučeni stručnjaci. ▶ Za pomicanje uređaja potrebne su dvije osobe. ▶ Koristite samo prikladan alat i opremu.

	⚠ OPREZ
	<p>Oštri rubovi! Porezotine</p> <ul style="list-style-type: none"> ▶ Nosite zaštitne rukavice.

	⚠ UPOZORENJE
	<p>Isklizavanje nagnutih uređaja! Puknuća kostiju / ozljede od prignječenja</p> <ul style="list-style-type: none"> ▶ Osigurajte uređaje od isklizavanja.



	⚠ OPREZ
	<p>Opasnost od padanja dijelova zbog otpuštenih vijaka! Ozljeda od dijelova koji padaju.</p> <ul style="list-style-type: none"> ▶ Osigurajte sastavne dijelove od pada.

	POZOR!
	<p>Opasnost od padanja dijelova zbog otpuštenih vijaka! Oštećenje drugih dijelova uređaja ili objekta klijenta, npr. poda.</p> <ul style="list-style-type: none"> ▶ Osigurajte sastavne dijelove od pada.

	⚠ OPASNOST
	<p>Opasnost od strujnog udara zbog dijelova koji provode struju! U slučaju nepravilnog popravka može doći do opasnosti za život od strujnog udara</p> <ul style="list-style-type: none"> ▶ Električne dijelove mora popraviti kvalificirani električar. ▶ Nakon popravka provedite sigurnosni test u skladu s VDE 0701 ili nacionalnim propisima.

	⚠ OPASNOST
	<p>Opasnost od strujnog udara zbog dijelova koji provode struju! Smrt od strujnog udara</p> <ul style="list-style-type: none"> ▶ Isključite uređaj iz električnog napajanja najmanje 60 sekundi prije izvođenja popravaka.

Zahtjev:

-  Uređaj je isključen iz napajanja.
-  Unutarnja oprema uređaja je uklonjena.

4.4.1 Uklanjanje gornjeg zgloba vrata

1. Gurnite potporni dio pod bazu.

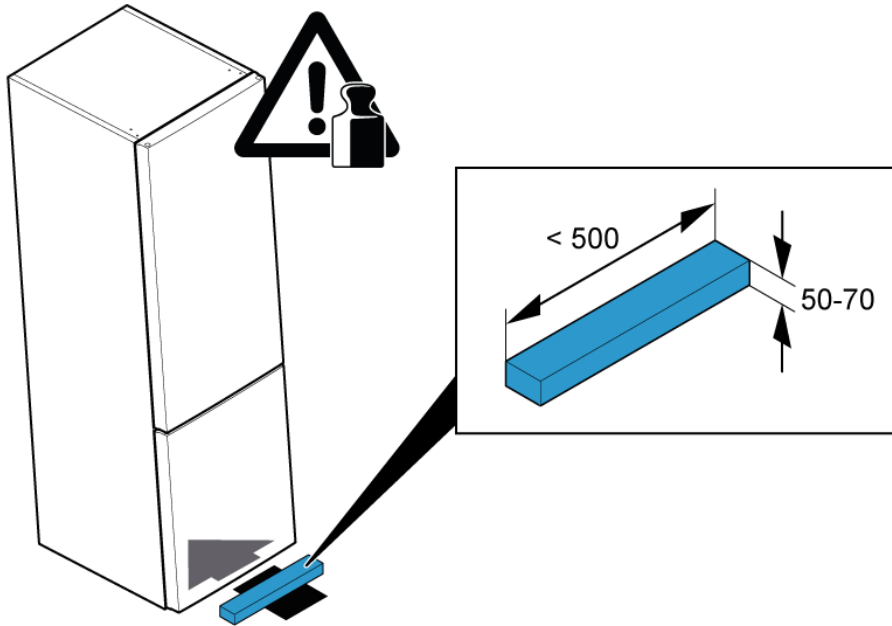

2. 1. Skinite poklopac gornjeg zgloba (1).
2. Odvojite električni priključak (2).
3. Odvijte vijak priključka za uzemljenje (3).

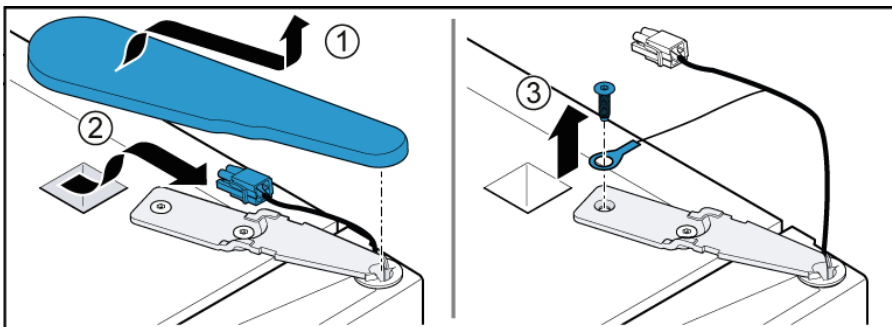

3. 1. Odvijte vijak (1).
2. Skinite gornji zglob (2).

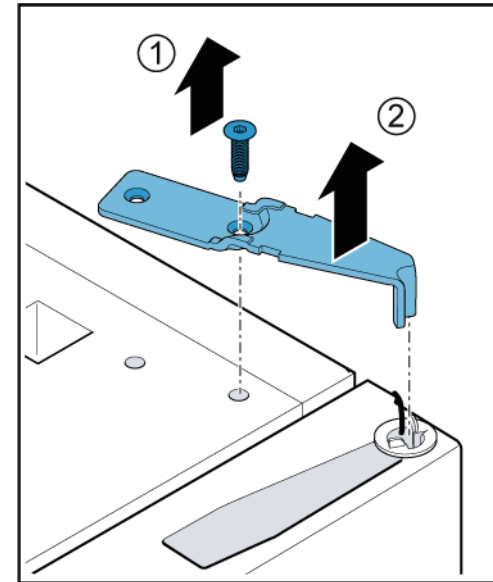

4. Skinite gornja vrata.

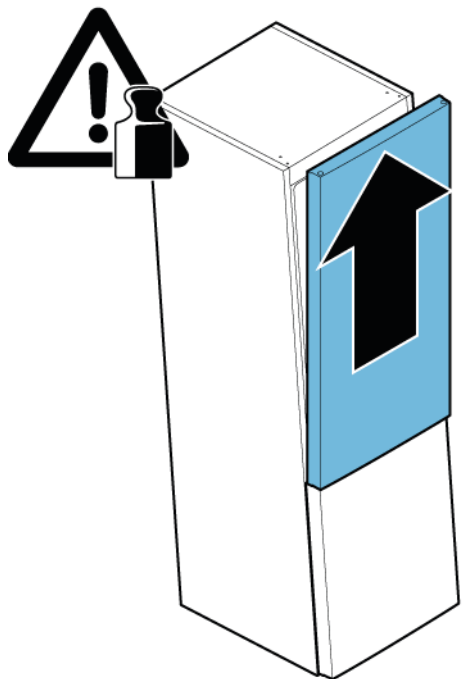

➡ Gornji je zglob skinut.

4.4.2 Postavljanje gornjeg zgloba vrata

- ▶ Postavite obratnim redoslijedom.

4.5 Zamjena srednjeg zgloba vrata

Specijalni alati:

🌀 Nastavak Torx TX20 6,3 mm (1/4") [00340865]

	⚠️ UPOZORENJE
	<p>Teški, veliki uređaji! Ozljede leđa i kralježnice</p> <ul style="list-style-type: none"> ▶ Uklanjanje vrata uređaja smiju obavljati samo obučeni stručnjaci. ▶ Za pomicanje uređaja potrebne su dvije osobe. ▶ Koristite samo prikladan alat i opremu.

	⚠️ OPREZ
	<p>Oštri rubovi! Porezotine</p> <ul style="list-style-type: none"> ▶ Nosite zaštitne rukavice.

	⚠️ UPOZORENJE
	<p>Isklizavanje nagnutih uređaja! Puknuća kostiju / ozljede od prignječenja</p> <ul style="list-style-type: none"> ▶ Osigurajte uređaje od isklizavanja.

	⚠️ OPREZ
	<p>Opasnost od padanja dijelova zbog otpuštenih vijaka! Ozljeda od dijelova koji padaju.</p> <ul style="list-style-type: none"> ▶ Osigurajte sastavne dijelove od pada.

	POZOR!
	<p>Opasnost od padanja dijelova zbog otpuštenih vijaka! Oštećenje drugih dijelova uređaja ili objekta klijenta, npr. poda.</p> <ul style="list-style-type: none"> ▶ Osigurajte sastavne dijelove od pada.

Zahtjev:

- ✔ Uređaj je isključen iz napajanja.
- ✔ Unutarnja je oprema uređaja uklonjena.
- ✔ Gornji je zglob vrata skinut.
- ✔ Gornja su vrata skinuta.

4.5.1 Uklanjanje srednjeg zgloba vrata

1. 1. Odvijte dva vijka (1).
2. Skinite srednji zglob (2).

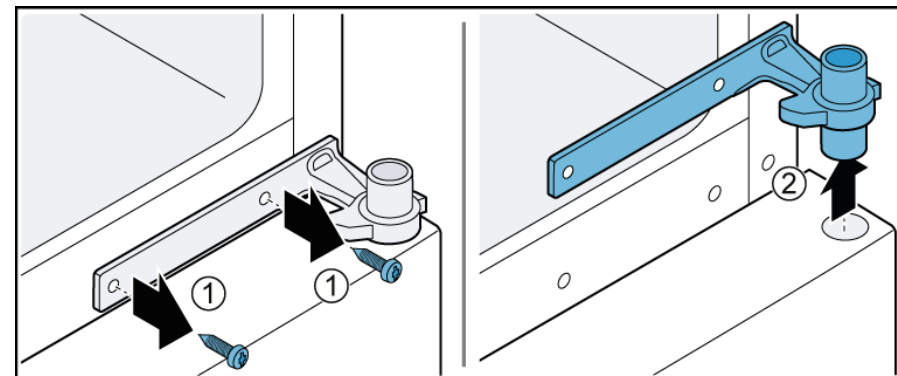

2. Uklonite donja vrata.

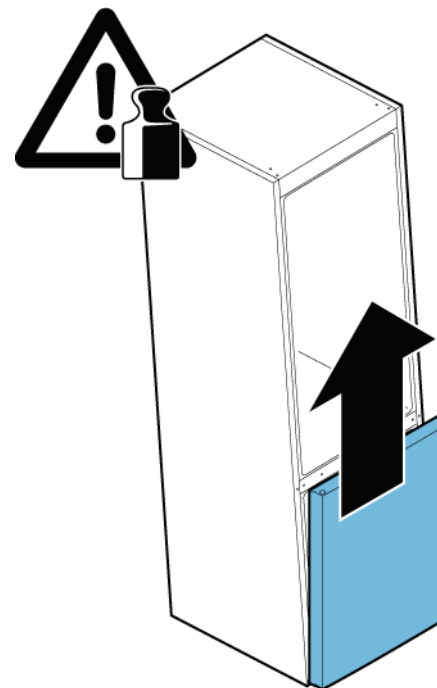

- ➡ Srednji je zglob skinut.

4.5.2 Postavljanje srednjeg zgloba vrata

- ▶ Postavite obratnim redoslijedom.

4.6 Zamjena donjeg zgloba vrata

Specijalni alati:

🌀 Nastavak Torx TX20 6,3 mm (1/4") [00340865]

	⚠️ UPOZORENJE
	<p>Teški, veliki uređaji! Ozljede leđa i kralježnice</p> <ul style="list-style-type: none"> ▶ Uklanjanje vrata uređaja smiju obavljati samo obučeni stručnjaci. ▶ Za pomicanje uređaja potrebne su dvije osobe. ▶ Koristite samo prikladan alat i opremu.

	⚠️ OPREZ
	<p>Oštri rubovi! Porezotine</p> <ul style="list-style-type: none"> ▶ Nosite zaštitne rukavice.

	⚠️ UPOZORENJE
	<p>Isklizavanje nagnutih uređaja! Puknuća kostiju / ozljede od prignječenja</p> <ul style="list-style-type: none"> ▶ Osigurajte uređaje od isklizavanja.

	⚠️ OPREZ
	<p>Opasnost od padanja dijelova zbog otpuštenih vijaka! Ozljeda od dijelova koji padaju.</p> <ul style="list-style-type: none"> ▶ Osigurajte sastavne dijelove od pada.

	POZOR!
	<p>Opasnost od padanja dijelova zbog otpuštenih vijaka! Oštećenje drugih dijelova uređaja ili objekta klijenta, npr. poda.</p> <ul style="list-style-type: none"> ▶ Osigurajte sastavne dijelove od pada.

Zahtjev:

- ✔ Uređaj je isključen iz napajanja.
- ✔ Unutarnja oprema uređaja je uklonjena.
- ✔ Gornji je zglob uklonjen.
- ✔ Srednji je zglob uklonjen.

4.6.1 Uklanjanje donjeg zgloba vrata

- ▶ 1. Odvijte dva vijka (1).
- ▶ 2. Skinite donji zglob (2).

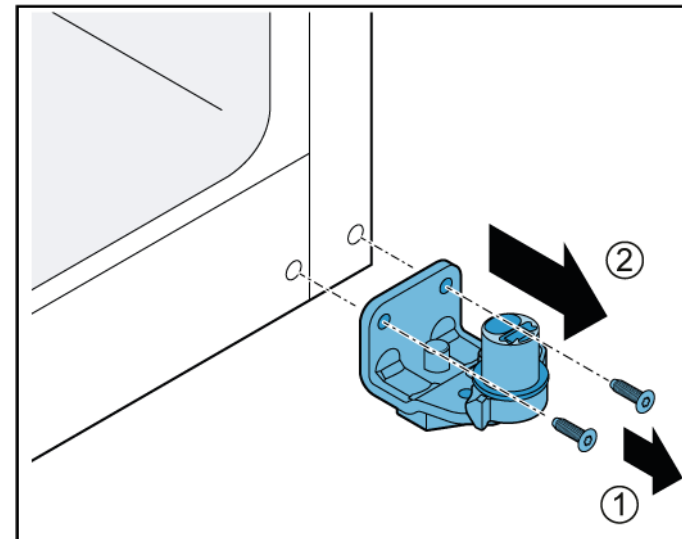

➡ Donji je zglob vrata skinut.

4.6.2 Postavljanje donjeg zgloba vrata

- ▶ Postavite obratnim redoslijedom.

4.7 Zamjena police

Zahtjev:

- ✔ Vrata su otvorena.

4.7.1 Uklanjanje police

- ▶ 1. Podignite stražnji dio police (1).
- ▶ 2. Otpustite policu (2).

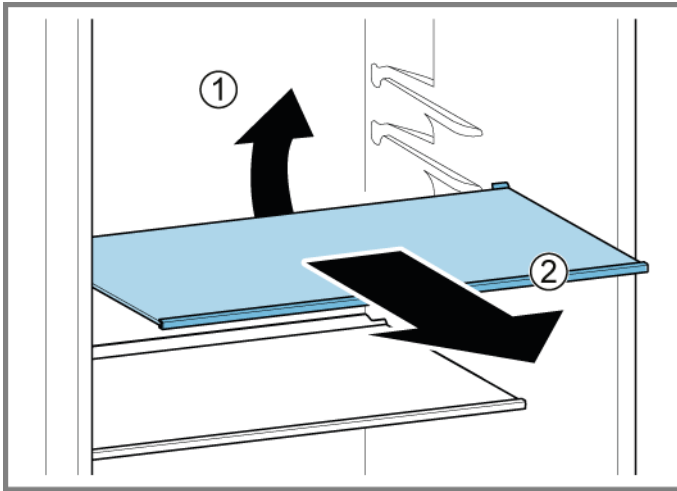

➡ Polica je skinuta.

4.7.2 Postavljanje police

- ▶ Postavite obratnim redoslijedom.

4.8 Zamjena police za boce

Zahtjev:

- ✔ Vrata su otvorena.

4.8.1 Uklanjanje police za boce

- ▶ Izvucite policu za boce.

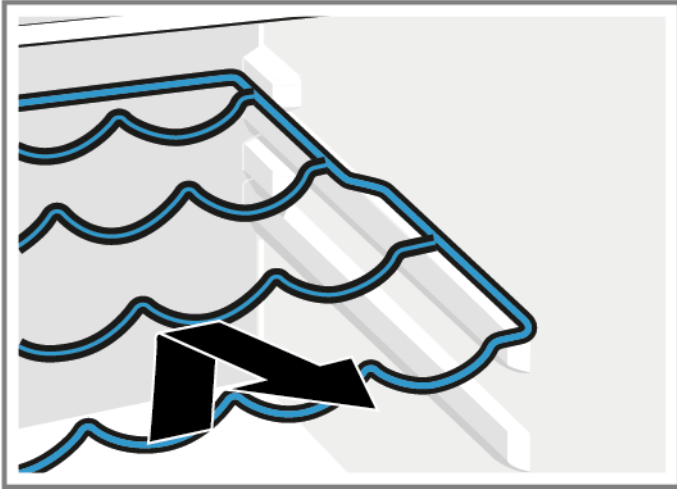

- ➡ Polica za boce je uklonjena.

4.8.2 Postavljanje police za boce

- ▶ Postavite obratnim redoslijedom.

4.9 Zamjena posude za vrata

Zahtjev:

- ✔ Vrata su otvorena.

4.9.1 Uklanjanje posude za vrata

- ▶ Podignite posudu za vrata prema gore.

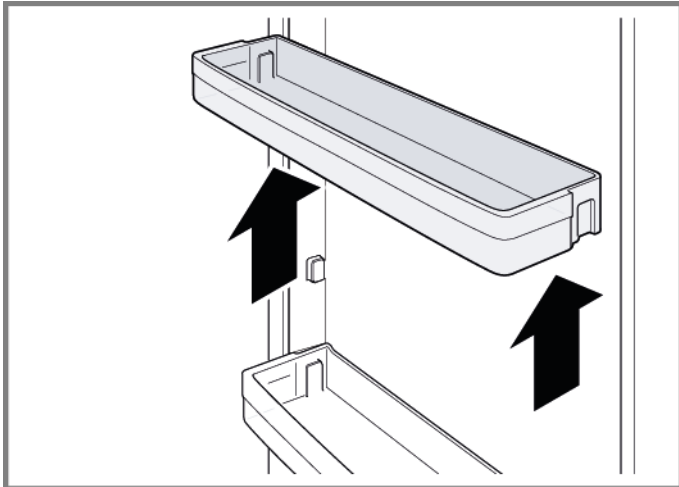

- ➡ Posuda za vrata je uklonjena.

4.9.2 Postavljanje posude za vrata

- ▶ Postavite obratnim redoslijedom.

4.10 Zamjena spremnika

Zahtjev:

- ✔ Vrata su otvorena.

4.10.1 Uklanjanje spremnika

1. Izvucite spremnik koliko je moguće.
2. 1. Podignite prednji dio spremnika (1).
2. Uklonite spremnik (2).

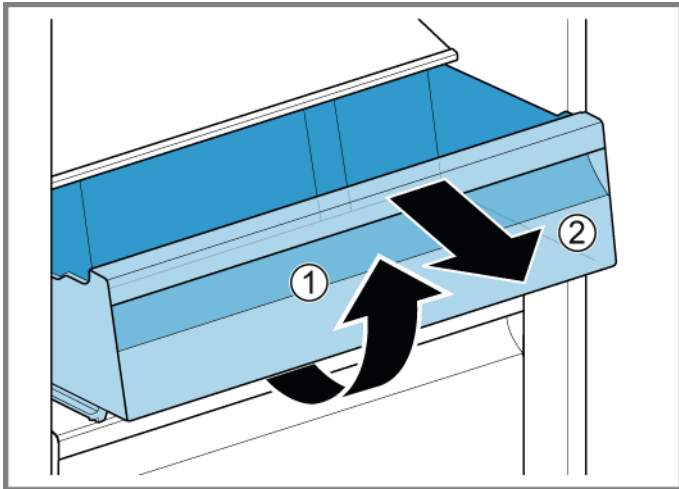

- ➔ Spremnik je uklonjen.

4.10.2 Ugradnja spremnika

- ▶ Postavite obratnim redoslijedom.

4.11 Zamjena spremnika za voće i povrće

Zahtjev:

- ✔ Vrata su otvorena.

4.11.1 Uklanjanje spremnika za voće i povrće

1. Izvucite spremnik za voće i povrće koliko je moguće.
2. 1. Podignite prednji dio spremnika za voće i povrće (1).
2. Uklonite spremnik (2).

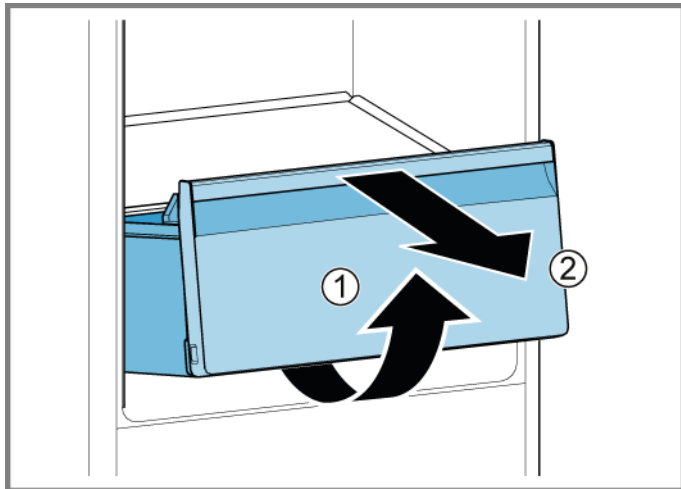

- ➡ Spremnik za voće i povrće je uklonjen.

4.11.2 Postavljanje spremnika za voće i povrće

- ▶ Postavite obratnim redoslijedom.

4.12 Zamjena police iznad spremnika za voće i povrće

Zahtjev:

- ✔ Vrata su otvorena.
- ✔ [Spremnik za voće i povrće je uklonjen.→53](#)

4.12.1 Uklanjanje police iznad spremnika za voće i povrće

1. Gurnite brtveni okvir prema gore i van.

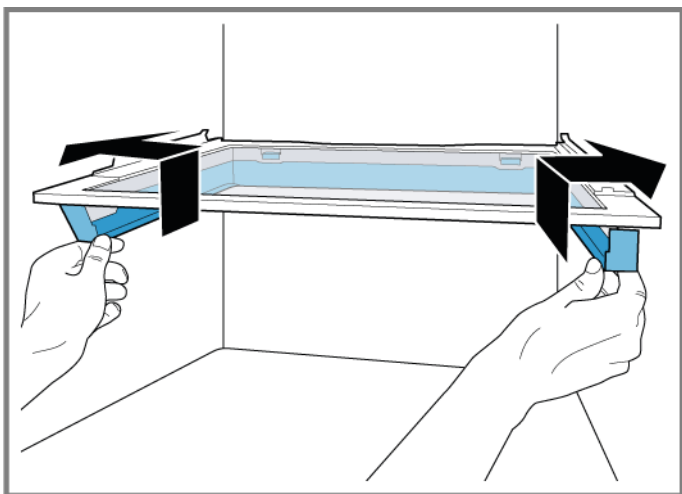

- ➡ Bočne se kuke otpuštaju.

2. Podignite brtveni okvir i gurnite ga unatrag.

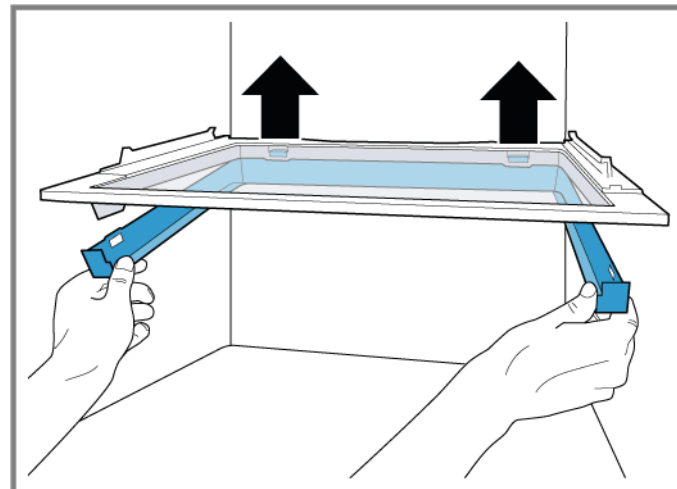

- ➡ Stražnje se kuke otpuštaju.

3. Uklonite brtveni okvir.
4. Podignite policu iznad spremnika za voće i povrće i zakrenite je bočno.

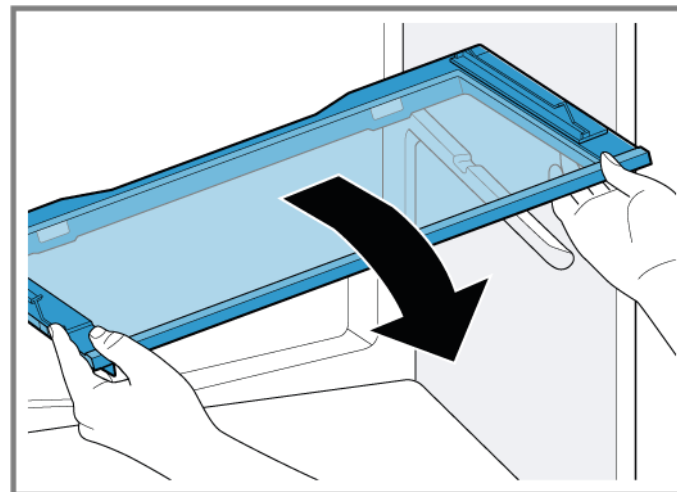

- ➡ Polica iznad spremnika za voće i povrće je uklonjena.

4.12.2 Ugradnja police iznad spremnika za voće i povrće

- ▶ Postavite obratnim redoslijedom.

4.13 Zamjena spremnika za zamrznute namirnice

Zahtjev:

- ✔ Vrata su otvorena.

4.13.1 Uklanjanje spremnika za zamrznute namirnice

- ▶ 1. Potpuno izvucite spremnik za zamrznute namirnice (1).
- ▶ 2. Uklonite spremnik za hranu (2).

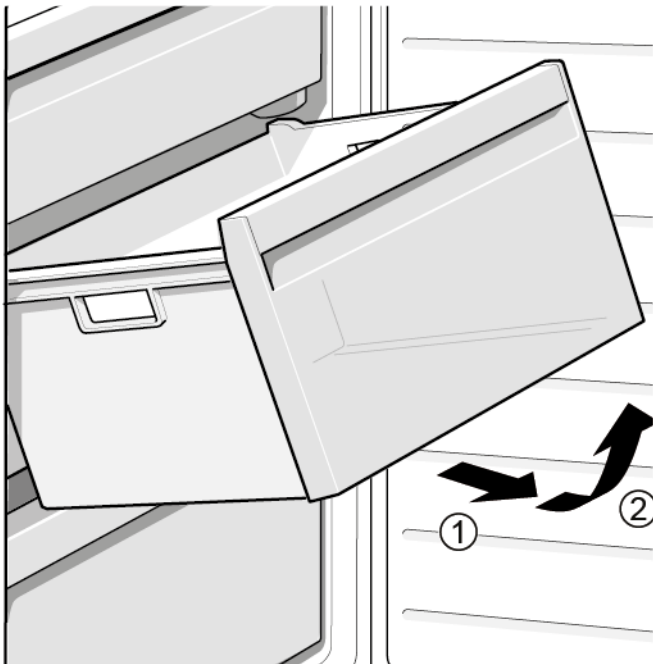

- ➡ Spremnik za zamrznute namirnice je uklonjen.

4.13.2 Postavljanje spremnika za zamrznute namirnice

- ▶ Postavite obratnim redoslijedom.

4.14 Zamjena gornje LED svjetiljke

Specijalni alati:

🔧 Specijalni alat

[00342180]



Uređaj ima LED svjetlo koje nije potrebno održavati.
Ta svjetla smiju popravljati samo služba za korisnike i ovlašteni tehničari!



⚠️ OPASNOST

Opasnost od strujnog udara zbog dijelova koji provode struju!

U slučaju nepravilnog popravka može doći do opasnosti za život od strujnog udara

- ▶ Električne dijelove mora popraviti kvalificirani električar.
- ▶ Nakon popravka provedite sigurnosni test u skladu s VDE 0701 ili nacionalnim propisima.



⚠️ OPASNOST

Opasnost od strujnog udara zbog dijelova koji provode struju!

Smrt od strujnog udara

- ▶ Isključite uređaj iz električnog napajanja najmanje 60 sekundi prije izvođenja popravaka.



⚠️ OPREZ

Oštri rubovi!

Porezotine

- ▶ Nosite zaštitne rukavice.

Zahtjev:

- ✔ Uređaj je isključen iz napajanja.
- ✔ Vrata su otvorena.

4.14.1 Uklanjanje gornje LED svjetiljke

1. Gurnite alat za demontažu između gornje LED svjetiljke i unutarnjeg sloja odjeljka hladnjaka kako biste otpustili kuke svjetiljke (1).
2. Uklonite gornju LED svjetiljku (2).

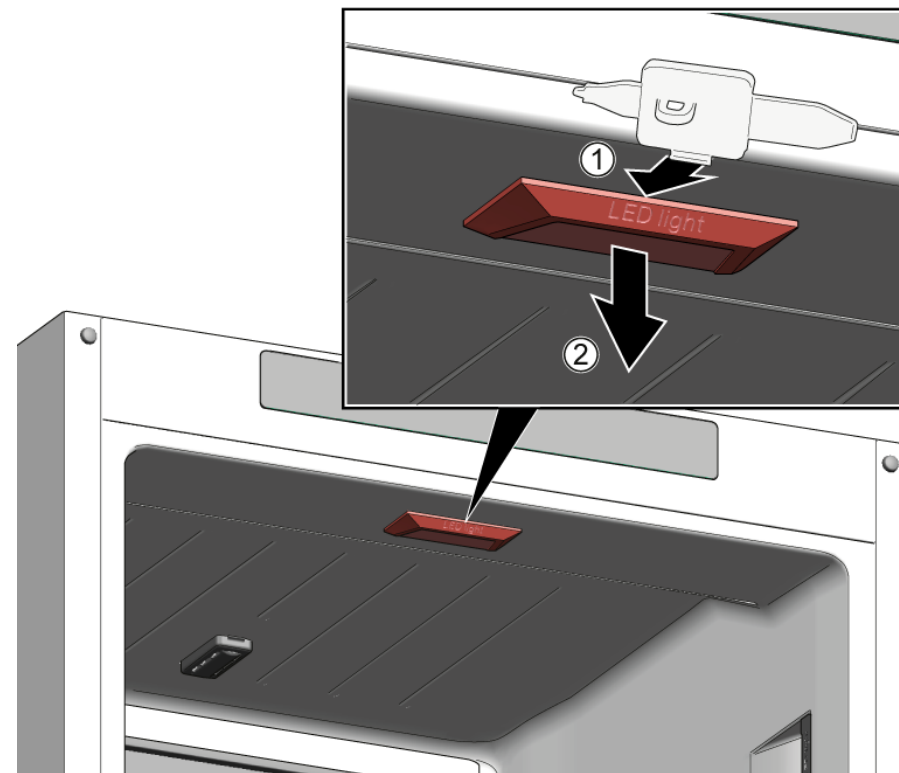

2. Odvojite električni priključak gornje LED svjetiljke.
- ➡ Gornja je LED svjetiljka uklonjena.

4.14.2 Ugradnja gornje LED svjetiljke

- ▶ Postavite obratnim redoslijedom.

4.15 Zamjena bočne LED svjetiljke

Specijalni alati:

🔧 Specijalni alat [00342180]

i Uređaj ima LED svjetlo koje nije potrebno održavati.
Ta svjetla smiju popravljati samo služba za korisnike i ovlašteni tehničari!

⚠️ OPASNOST
Opasnost od strujnog udara zbog dijelova koji provode struju!
U slučaju nepravilnog popravka može doći do opasnosti za život od strujnog udara

- ▶ Električne dijelove mora popraviti kvalificirani električar.
- ▶ Nakon popravka provedite sigurnosni test u skladu s VDE 0701 ili nacionalnim propisima.

⚠️ OPASNOST
Opasnost od strujnog udara zbog dijelova koji provode struju!
Smrt od strujnog udara

- ▶ Isključite uređaj iz električnog napajanja najmanje 60 sekundi prije izvođenja popravaka.

⚠️ OPREZ
Oštri rubovi!
Porezotine

- ▶ Nosite zaštitne rukavice.

⚠️ POZORI!
Opasnost od oštećenja elektrostatički osjetljivih sastavnih dijelova (ESD)!
Oštećenje komponenti

- ▶ Prije nego što dodirnete elektrostatičke osjetljive sastavne dijelove upotrijebite sustav za zaštitu od elektrostatskog naboja (narukvica sa sigurnosnim utikačem za uzemljenje).
- ▶ Nemojte dodirivati priključke i rute vodiča na modelu.
- ▶ Elektrostatički osjetljive sastavne dijelove transportirajte samo u vodljivim materijalima ili originalnom pakiranju.
- ▶ Držite elektrostatički osjetljive sastavne dijelove podalje od materijala koji se mogu elektrostatički puniti (npr. plastike).

Zahtjev:

- ✓ Uređaj je isključen iz napajanja.
- ✓ Vrata su otvorena.
- ✓ Unutarnja RC oprema je uklonjena.

4.15.1 Uklanjanje bočne LED svjetiljke

1. Gurnite alat za demontažu između raspršivača svjetiljke i kućišta da biste otpustili kuku (1).
2. Izvadite raspršivač svjetiljke (2).
3. Otpustite sljedeće kuke za pričvršćivanje raspršivača na isti način.

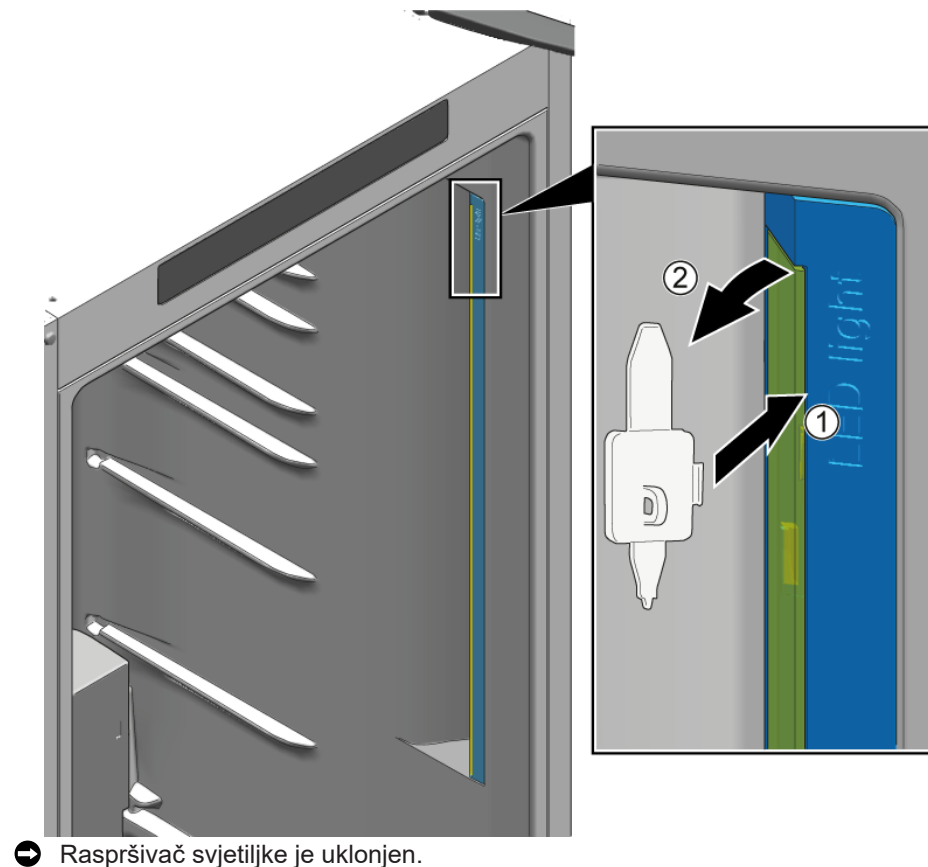

Popravak

1. Pritisnite kuku za pričvršćivanje kako biste je otpustili (1).
2. Pomaknite LED modul prema gore približno 1 cm kako biste ga uklonili za odspajanje iz utičnice (2).
3. Uklonite LED modul (3).

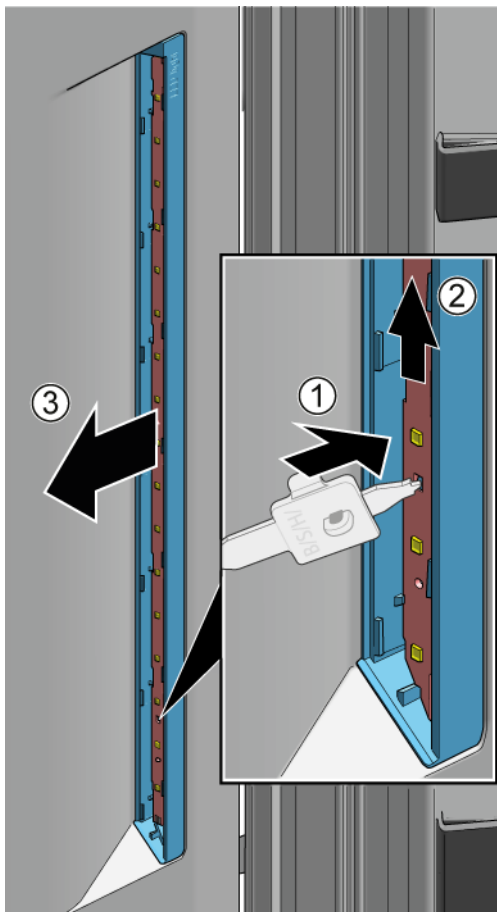

 Bočna LED svjetiljka je uklonjena.

4.15.2 Ugradnja bočne LED svjetiljke



Budući da se kuke raspršivača svjetiljke mogu lako slomiti tijekom postupka uklanjanja, komplet rezervne bočne LED svjetiljke sadrži LED modul i raspršivač svjetiljke.

1. Gurnite alat za demontažu između raspršivača svjetiljke i kućišta da biste otpustili kuku (1).
2. Izvadite raspršivač svjetiljke (2).
3. Otpustite sljedeće kuke za pričvršćivanje raspršivača na isti način.

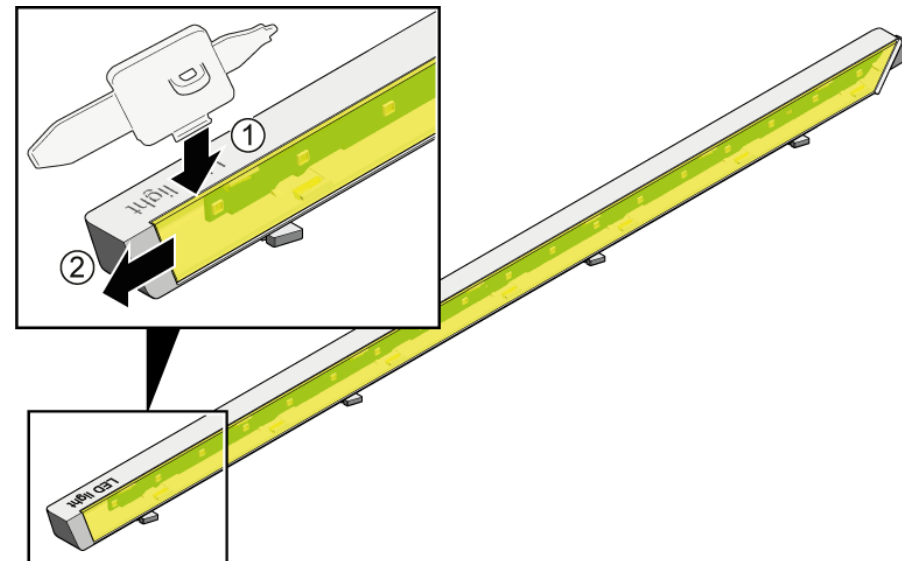

Popravak

1. Pritisnite kuku za pričvršćivanje kako biste je otpustili (1).
2. Izvucite LED modul prema gore iz kućišta.
3. Zbrinite kućište LED modula koje se upotrebljava iz sigurnosnih razloga za transport rezervnih dijelova (3).

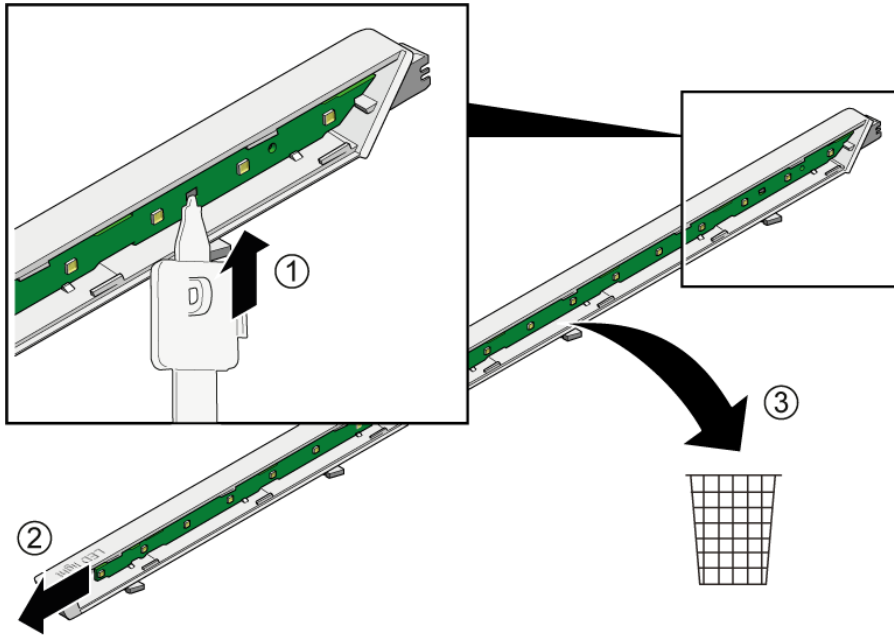

3. Ugradite LED modul i raspršivač svjetiljke obrnutim redoslijedom od načina na koji su uklonjeni.

4.16 Zamjena LED svjetiljke zamrzivača

Specijalni alati:

🔧 Specijalni alat [00342180]

i Uređaj ima LED svjetlo koje nije potrebno održavati.
Ta svjetla smiju popravljati samo služba za korisnike i ovlašteni tehničari!

⚠️ OPASNOST
Opasnost od strujnog udara zbog dijelova koji provode struju!
U slučaju nepravilnog popravka može doći do opasnosti za život od strujnog udara

- ▶ Električne dijelove mora popraviti kvalificirani električar.
- ▶ Nakon popravka provedite sigurnosni test u skladu s VDE 0701 ili nacionalnim propisima.

⚠️ OPASNOST
Opasnost od strujnog udara zbog dijelova koji provode struju!
Smrt od strujnog udara

- ▶ Isključite uređaj iz električnog napajanja najmanje 60 sekundi prije izvođenja popravaka.

⚠️ OPREZ
Oštri rubovi!
Porezotine

- ▶ Nosite zaštitne rukavice.

Zahtjev:

- ✔️ Uređaj je isključen iz napajanja.
- ✔️ Vrata su otvorena.

4.16.1 Uklanjanje LED svjetiljke zamrzivača

- ▶ 1. Gurnite alat za demontažu između svjetiljke i kućišta na bočnom dijelu svjetiljke kako biste stvorili razmak (1).
- ▶ 2. Gurnite alat za demontažu na drugu stranu pričvrstne kuke svjetiljke i zakrenite ga unaprijed (2).
- ▶ 3. Uklonite LED svjetiljku zamrzivača (3).

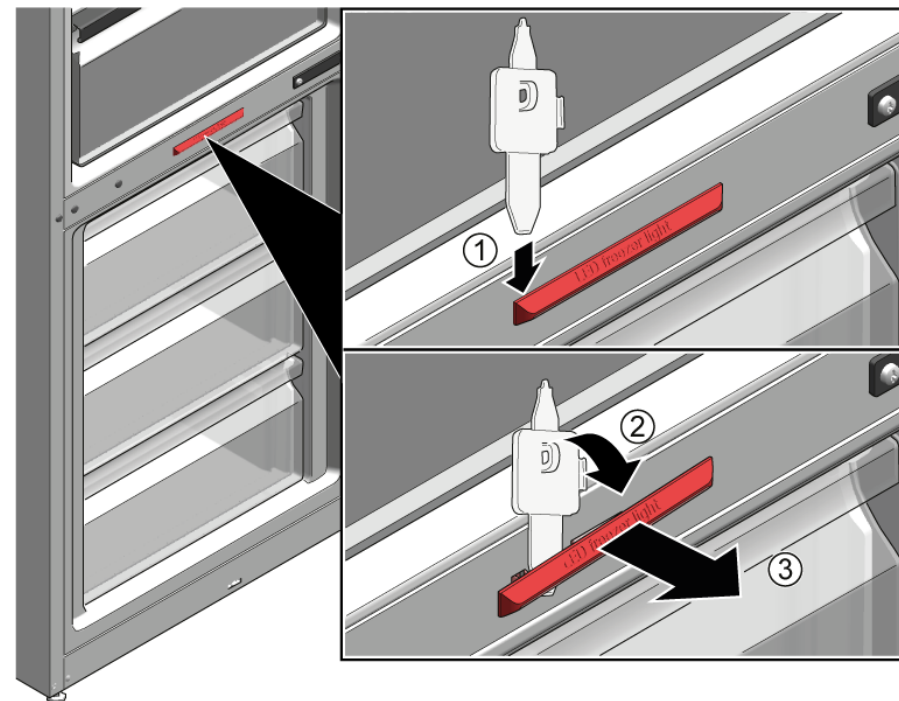





- ➡️ LED svjetiljka zamrzivača je odspojena.
- ➡️ LED svjetiljka zamrzivača je uklonjena.

4.16.2 Ugradnja LED svjetiljke zamrzivača

- ▶ Postavite obratnim redoslijedom.

Poznámky k opravě - Kombinace chladničky s mrazničkou

 O tomto dokumentu	63		
1.1 Důležité informace	63		
1.1.1 Účel	63		
1.2 Vysvětlení symbolů	63		
1.2.1 Úroveň nebezpečí	63		
1.2.2 Symboly nebezpečí	63		
1.2.3 Struktura výstrah	64		
1.2.4 Obecné symboly	64		
 Bezpečnost	65		
2.1 Všeobecné bezpečnostní pokyny	65		
2.1.1 Všechny domácí spotřebiče	65		
 Nástroje a pomůcky	66		
 Oprava	67		
4.1 Výměna těsnění dvířek	67		
4.1.1 Vyjmutí těsnění dvířek	67		
4.1.2 Montáž těsnění dvířek	67		
4.2 Výměna madla dvířek	70		
4.2.1 Vyjmutí madla dvířek	70		
4.2.2 Montáž madla dvířek	70		
4.3 Výměna horního závěsu dvířek	71		
4.3.1 Vyjmutí horního závěsu dvířek	71		
4.3.2 Montáž horního závěsu	72		
4.4 Výměna horního závěsu dvířek (dvířka s ukazatelem)	73		
4.4.1 Vyjmutí horního závěsu dvířek	74		
4.4.2 Montáž horního závěsu	75		
4.5 Výměna středního závěsu dvířek	76		
4.5.1 Vyjmutí středního závěsu dvířek	76		
4.5.2 Montáž středního závěsu dvířek	77		
4.6 Výměna dolního závěsu dvířek	78		
4.6.1 Vyjmutí spodního závěsu dvířek	78		
4.6.2 Montáž spodního závěsu dvířek	78		
4.7 Výměna odkládací plochy	79		
4.7.1 Vyjmutí odkládací plochy	79		
4.7.2 Montáž odkládací plochy	79		
4.8 Výměna držáku na láhve	80		
4.8.1 Vyjmutí držáku na láhve	80		
4.8.2 Montáž držáku na láhve	80		
4.9 Výměna dveřní přihrádky	81		
4.9.1 Vyjmutí dveřní přihrádky	81		
4.9.2 Montáž dveřní přihrádky	81		
4.10 Výměna zásobníku	82		
4.10.1 Vyjmutí zásobníku	82		
4.10.2 Montáž zásobníku	82		
4.11 Výměna zásobníku na ovoce a zeleninu	83		
4.11.1 Vyjmutí zásobníku na ovoce a zeleninu	83		
4.11.2 Montáž zásobníku na ovoce a zeleninu	83		
4.12 Výměna odkládací plochy nad zásobníkem na ovoce a zeleninu	84		
4.12.1 Vyjmutí odkládací plochy nad zásobníkem na ovoce a zeleninu	84		
4.12.2 Montáž odkládací plochy nad zásobníkem na ovoce a zeleninu	85		
4.13 Výměna zásobníku na zmrazené potraviny	86		
4.13.1 Vyjmutí zásobníku na zmrazené potraviny	86		
4.13.2 Montáž zásobníku na zmrazené potraviny	86		
4.14 Výměna horního LED osvětlení	87		
4.14.1 Demontáž horního LED osvětlení	87		
4.14.2 Montáž horního LED osvětlení	87		
4.15 Výměna bočního LED osvětlení	88		
4.15.1 Demontáž bočního LED osvětlení	88		
4.15.2 Montáž bočního LED osvětlení	89		
4.16 Výměna LED osvětlení v mrazničce	91		
4.16.1 Demontáž LED osvětlení v mrazničce	91		
4.16.2 Montáž LED osvětlení mrazničky	91		

i O tomto dokumentu

1.1 Důležité informace

1.1.1 Účel

Tyto pokyny k opravě pomáhají spotřebiteli při vlastnoruční opravě spotřebičů v souladu s platnými předpisy o ekodesignu (platnými k 03/2021).



Obsahují informace o výměně některých náhradních dílů včetně příslušných výstrah a nebezpečí.

V případě dotazů se obraťte na náš zákaznický servis. Za škody ručíme pouze v případě, že budou správně dodrženy pokyny k opravě.

1.2 Vysvětlení symbolů

1.2.1 Úroveň nebezpečí

Jednotlivé úrovně výstrah se skládají ze symbolu a signálního slova. Signální slova uvádějí závažnost nebezpečí.





Úroveň výstrahy	Význam
 NEBEZPEČÍ	Nedodržení výstražného upozornění způsobí smrt nebo vážná zranění.
 VÝSTRAHA	Nedodržení výstražného upozornění může způsobit smrt nebo vážná zranění.
 POZOR	Nedodržení výstražného upozornění může způsobit lehká zranění.
POZOR!	Nedodržení výstražného upozornění může způsobit škody na majetku.

Tabulka 1: Úroveň nebezpečí



1.2.2 Symboly nebezpečí

Symboly nebezpečí jsou symbolická znázornění určující druh nebezpečí.

V tomto dokumentu jsou použity následující symboly nebezpečí:

Symbol nebezpečí	Význam
	Obecné výstražné upozornění
	Nebezpečí vycházející z elektrického napětí
	Nebezpečí výbuchu
	Nebezpečí pořezání
	Nebezpečí rozdrcení



O tomto dokumentu

Symbol nebezpečí	Význam
	Nebezpečí spojené s horkými povrchy
	Nebezpečí vycházející ze silného elektromagnetického pole
	Nebezpečí z neionizujícího záření

Tabulka 2: Symboly nebezpečí

1.2.3 Struktura výstrah

Výstrahy použité v tomto dokumentu mají standardizovaný vzhled a strukturu.



	<div style="background-color: red; color: white; padding: 2px; text-align: center;"> NEBEZPEČÍ</div> <p>Typ a zdroj nebezpečí! Možné důsledky nedodržení výstražného upozornění.</p> <ul style="list-style-type: none"> ▶ Opatření a zákazy eliminující nebezpečí.
--	--





Následující příklad ukazuje výstrahu, která varuje před zásahem elektrickým proudem při dotyku dílů pod proudem. Je uvedeno opatření pro zabránění rizika.

	<div style="background-color: red; color: white; padding: 2px; text-align: center;"> NEBEZPEČÍ</div> <p>Nebezpečí úrazu elektrickým proudem při dotyku dílů pod proudem! Usmrcení elektrickým proudem</p> <ul style="list-style-type: none"> ▶ Odpojte spotřebič od přívodu elektrického proudu alespoň 60 sekund před zahájením opravy.
---	--

1.2.4 Obecné symboly

V tomto dokumentu jsou použity následující obecné symboly:

Obecný symbol	Význam
	Uvedení zvláštního tipu (text nebo grafické vyjádření)
	Uvedení jednoduchého tipu (pouze text)
	Uvedení odkazu k videonávodu

Obecný symbol	Význam
	Uvedení požadovaných nástrojů
	Uvedení požadovaných podmínek
	Uvedení podmínky (když, pak atd.)
	Uvedení výsledku
[Start]	Uvedení klávesy nebo tlačítka
[00123456]	Uvedení čísla materiálu
Status	Uvedení zobrazeného textu / okna (na ukazateli spotřebiče)

Tabulka 3: Obecné symboly

2.1 Všeobecné bezpečnostní pokyny

2.1.1 Všechny domácí spotřebiče

Nebezpečí úrazu elektrickým proudem při dotyku dílů pod proudem!

- Chyby při opravě elektrických součástí mohou vést k úrazu elektrickým proudem!
- Odpojte spotřebič ze sítě alespoň 60 sekund před zahájením prací.
- Po opravě nechte provést bezpečnostní zkoušku podle VDE 0701 nebo specifických předpisů dané země.

Nebezpečí poranění o ostré hrany!

- Používejte ochranné rukavice.

Nebezpečí rozdrčení během opravy, údržby, odstranění závad a servisu těžkými a pohyblivými součástmi

- Používejte bezpečnostní obuv.
- Zajistěte těžké součásti před pádem.
- Nesahejte na pohyblivé součásti.

Nebezpečí z hlediska bezpečnosti / funkce spotřebiče!

- Používejte pouze originální náhradní díly.

Nebezpečí poškození elektrostaticky citlivých součástí (elektrostatický výboj)!

- Nedotýkejte se modulů, včetně přípojek a vodičů.

Nástroje a pomůcky

Označení	Detaily	Snímky
Torx Bit TX20 [00340865]	6,3 mm (1/4")	
Speciální nástroj [00342180]		

4.1 Výměna těsnění dvířek

Požadavek:

- ✔ Dvířka jsou otevřená.

4.1.1 Vyjmutí těsnění dvířek

1. Uvolněte těsnění dvířek z drážky v pravém a levém rohu.



2. Vytáhněte těsnění z drážky.



- ➡ Těsnění dvířek je vyjmuté.

4.1.2 Montáž těsnění dvířek



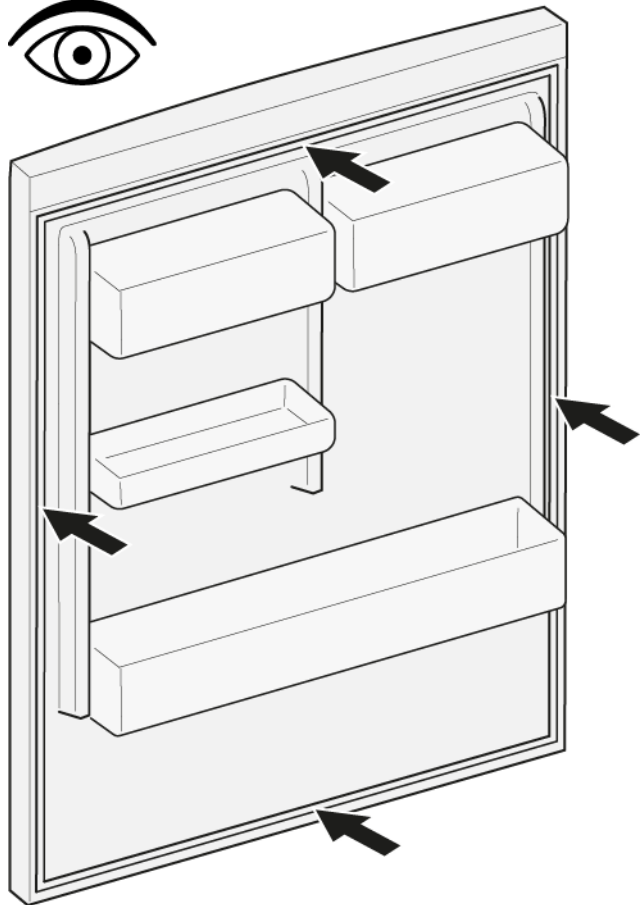

Nové těsnění dvířek může mít trochu jinou šířku než původní těsnění. Dovření dvířek ani dlouhodobá funkce tím nebudou ovlivněny. Pokud má spotřebič nastavitelné závěsy nebo nástavce závěsů, můžete dovření dvířek následně upravit. Malé boční otvory v těsnění dvířek jsou funkční (slouží pro přívod vzduchu). Nejsou vadou výrobku.

1. Zkontrolujte, zda není poškozena drážka těsnění.

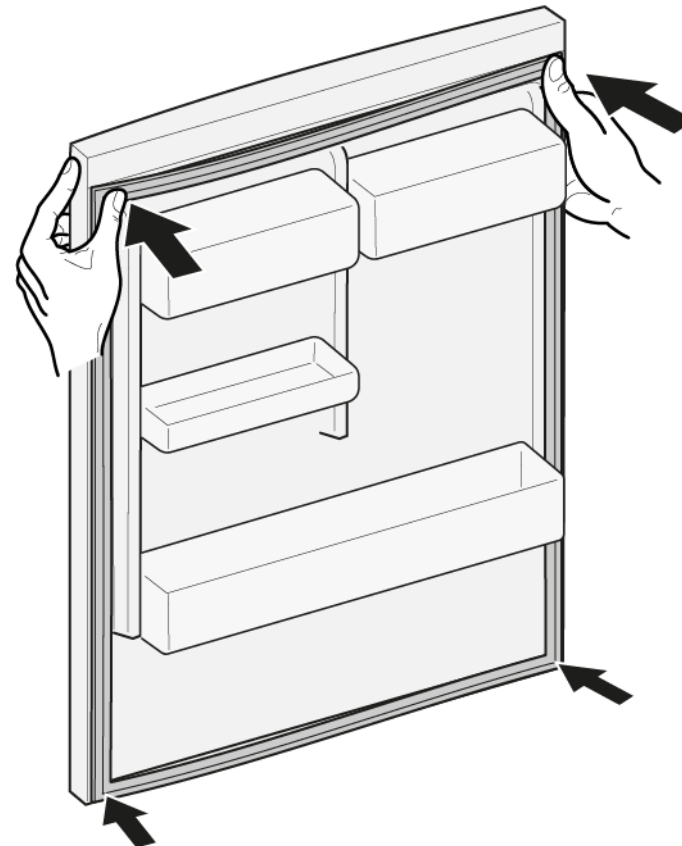

4. Zatlačte horní a dolní rohy těsnění do drážky.



2.  Pokud je drážka těsnění poškozená,
- kontaktujte zákaznický servis.

3.  Lehká deformace těsnění dvířek je normální a nemá vliv na jeho funkci. Před vložením do spotřebiče doporučujeme těsnění narovnat.

Těsnění zahřejte fénem nebo horkou vodou a manuálně upravte jeho tvar.

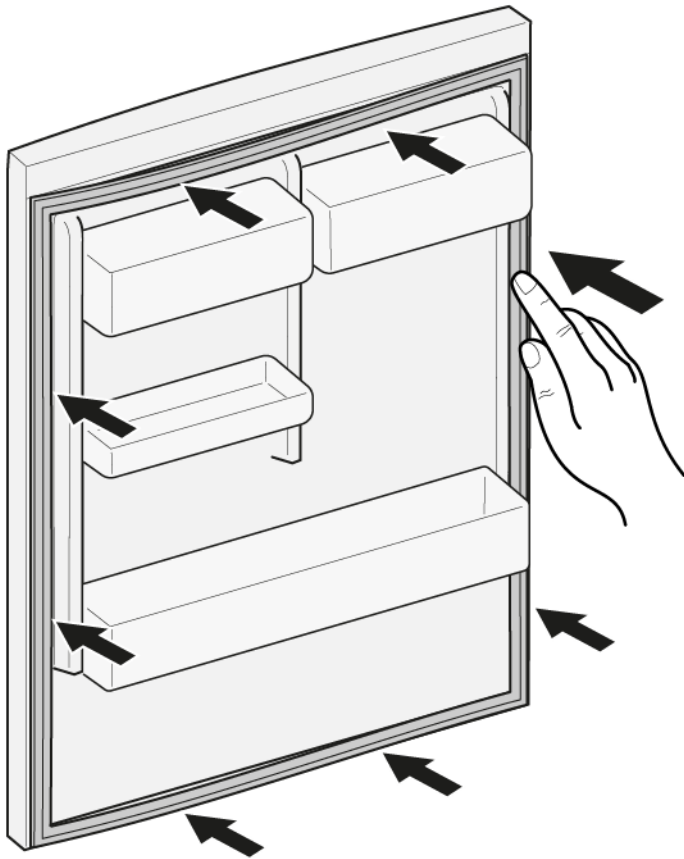

5. Postupně zatlačte do drážky celé těsnění.





 Těsnění dvířek je namontované.

4.2 Výměna madla dvířek

Speciální nástroje:

-  Torx Bit TX20 6,3 mm (1/4") [00340865]
-  Plochý šroubovák Čepel 10 mm x 1,6 mm x 200 mm

Požadavek:

-  Spotřebič je odpojený od přívodu elektrické energie.
-  Dvířka jsou otevřená.

4.2.1 Vyjmutí madla dvířek

- ▶ 1. Odstraňte dvě krytky šroubů (1).
- ▶ 2. Vyšroubujte dva šrouby (2).
- ▶ 3. Vyjměte madlo dvířek (3).

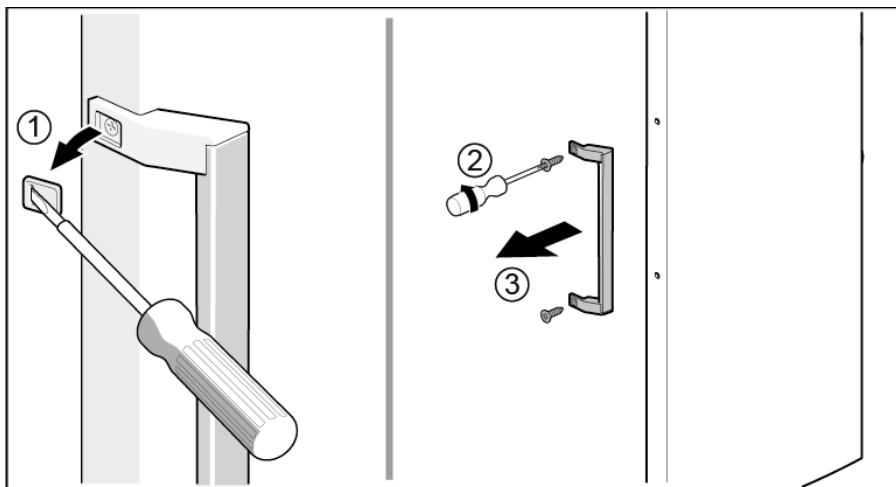

 Madlo dvířek je vyjmuté.



Madlo druhých dvířek může být vyjmuto stejným způsobem.

4.2.2 Montáž madla dvířek

- ▶ Montáž proveďte v opačném sledu.

4.3 Výměna horního závěsu dvířek

Speciální nástroje:

Torx Bit TX20

6,3 mm (1/4")

[00340865]

	⚠ VÝSTRAHA
	<p>Těžké, objemné spotřebiče! Poranění zad a svalů</p> <ul style="list-style-type: none"> ▶ Odstranění dvířek spotřebiče by měl provádět výhradně školený odborník. ▶ Pro manipulaci se spotřebičem jsou nutní dva lidé. ▶ Použijte pouze vhodné nástroje a zařízení.

	⚠ POZOR
	<p>Ostré hrany! Nebezpečí řezných poranění</p> <ul style="list-style-type: none"> ▶ Používejte ochranné rukavice.

	⚠ VÝSTRAHA
	<p>Sklouznutí nakloněných spotřebičů! Zlomeniny / poranění rozdrcením</p> <ul style="list-style-type: none"> ▶ Zajistěte spotřebiče proti sklouznutí.

	⚠ POZOR
	<p>Nebezpečí padajících dílů kvůli uvolněným šroubům! Poranění padajícími díly.</p> <ul style="list-style-type: none"> ▶ Zajistěte jednotlivé součásti před pádem.

	POZOR!
	<p>Nebezpečí padajících dílů kvůli uvolněným šroubům! Poškození jiných částí spotřebiče nebo prvků domácnosti zákazníka, např. podlahy.</p> <ul style="list-style-type: none"> ▶ Zajistěte jednotlivé součásti před pádem.

Požadavek:

- Spotřebič je odpojený od přívodu elektrické energie.
- Vnitřní kování spotřebiče je odstraněno.

4.3.1 Vyjmutí horního závěsu dvířek

1. Posuňte podpurnou část pod základní díl.

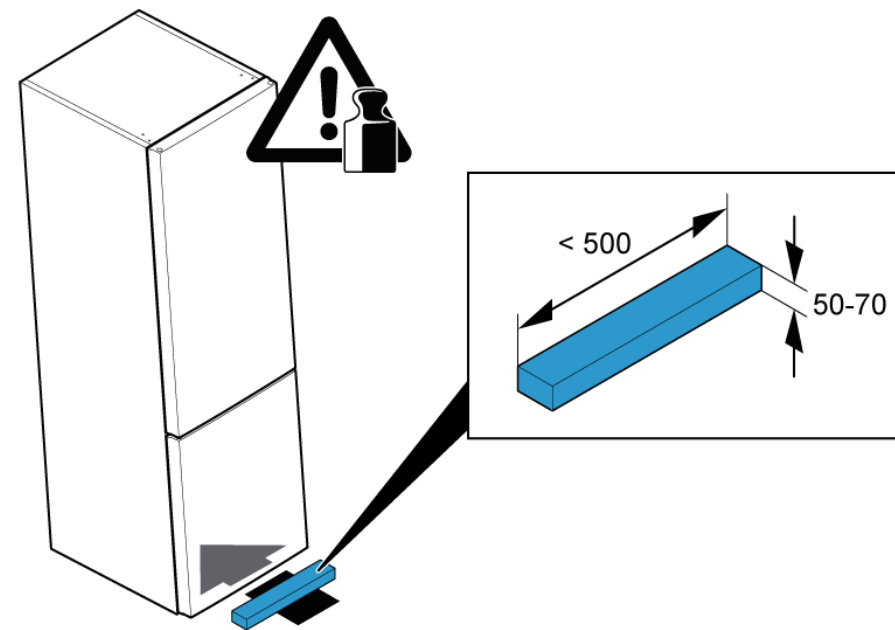

2. 1. Odstraňte kryt horního závěsu (1).
2. Vyšroubujte dva šrouby (2).
3. Vyjměte horní závěs (3).

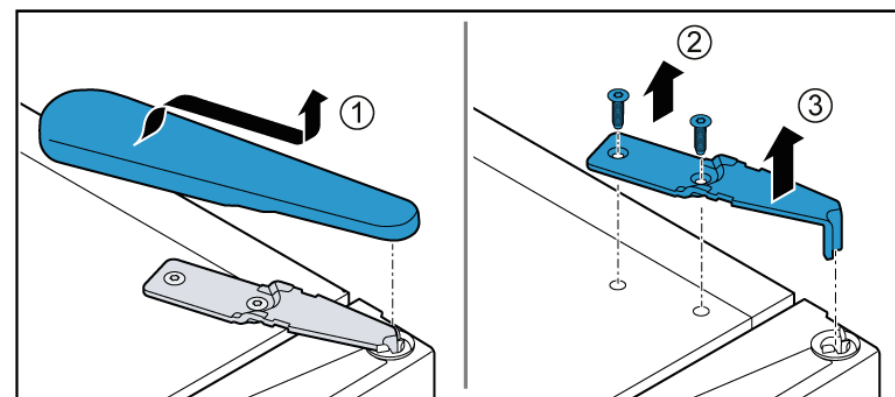

3. Vyměte horní dvířka.

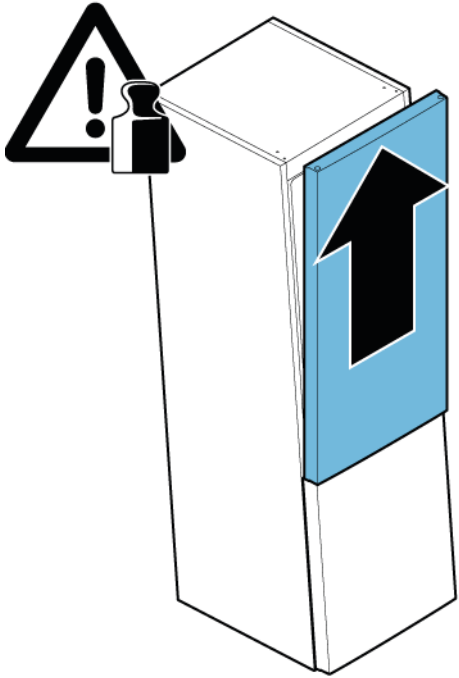

➡ Horní závěs je vyjmutý.

4.3.2 Montáž horního závěsu

▶ Montáž proveďte v opačném sledu.

4.4 Výměna horního závěsu dvířek (dvířka s ukazatelem)

Speciální nástroje:

 Torx Bit TX20 6,3 mm (1/4") [00340865]

	⚠ VÝSTRAHA
	<p>Těžké, objemné spotřebiče! Poranění zad a svalů</p> <ul style="list-style-type: none"> ▶ Odstranění dvířek spotřebiče by měl provádět výhradně školený odborník. ▶ Pro manipulaci se spotřebičem jsou nutní dva lidé. ▶ Použijte pouze vhodné nástroje a zařízení.

	⚠ POZOR
	<p>Ostré hrany! Nebezpečí řezných poranění</p> <ul style="list-style-type: none"> ▶ Používejte ochranné rukavice.

	⚠ VÝSTRAHA
	<p>Sklouznutí nakloněných spotřebičů! Zlomeniny / poranění rozdrcením</p> <ul style="list-style-type: none"> ▶ Zajistěte spotřebiče proti sklouznutí.



	⚠ POZOR
	<p>Nebezpečí padajících dílů kvůli uvolněným šroubům! Poranění padajícími díly.</p> <ul style="list-style-type: none"> ▶ Zajistěte jednotlivé součásti před pádem.

	POZOR!
	<p>Nebezpečí padajících dílů kvůli uvolněným šroubům! Poškození jiných částí spotřebiče nebo prvků domácnosti zákazníka, např. podlahy.</p> <ul style="list-style-type: none"> ▶ Zajistěte jednotlivé součásti před pádem.

	⚠ NEBEZPEČÍ
	<p>Nebezpečí úrazu elektrickým proudem při dotyku dílů pod proudem! V případě neodborné opravy hrozí nebezpečí smrtelného úrazu elektrickým proudem</p> <ul style="list-style-type: none"> ▶ Opravu elektrického zařízení smí provádět jen kvalifikovaný elektrikář. ▶ Po opravě nechte provést bezpečnostní zkoušku podle VDE 0701 nebo specifických předpisů dané země.

	⚠ NEBEZPEČÍ
	<p>Nebezpečí úrazu elektrickým proudem při dotyku dílů pod proudem! Usmrcení elektrickým proudem</p> <ul style="list-style-type: none"> ▶ Odpojte spotřebič od přívodu elektrického proudu alespoň 60 sekund před zahájením opravy.

Požadavek:

-  Spotřebič je odpojený od přívodu elektrické energie.
-  Vnitřní kování spotřebiče je odstraněno.

4.4.1 Vyjmutí horního závěsu dvířek

1. Posuňte podpůrnou část pod základní díl.

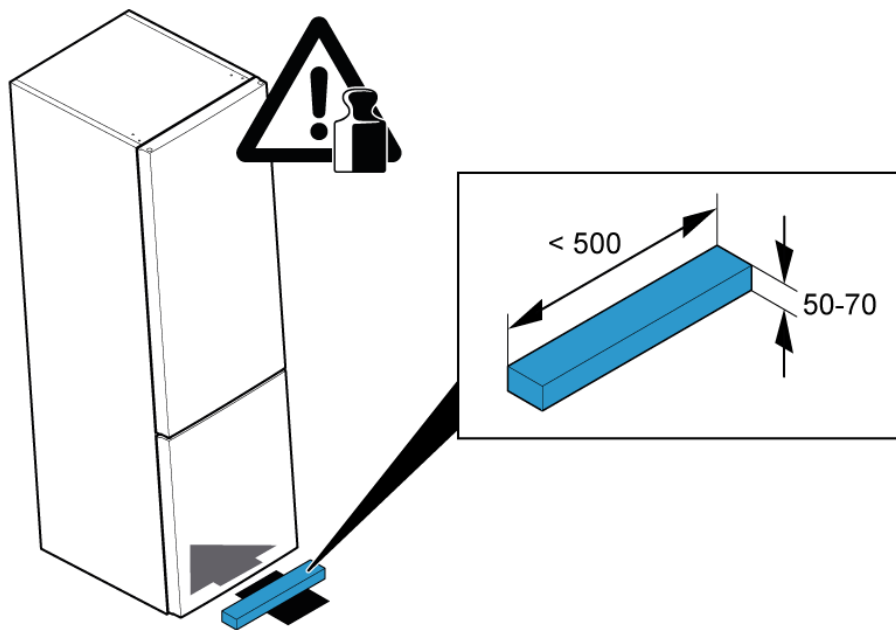

2. 1. Odstraňte kryt horního závěsu (1).
2. Odpojte elektrické připojení (2).
3. Vyšroubujte šroub zemnicí přípojky (3).

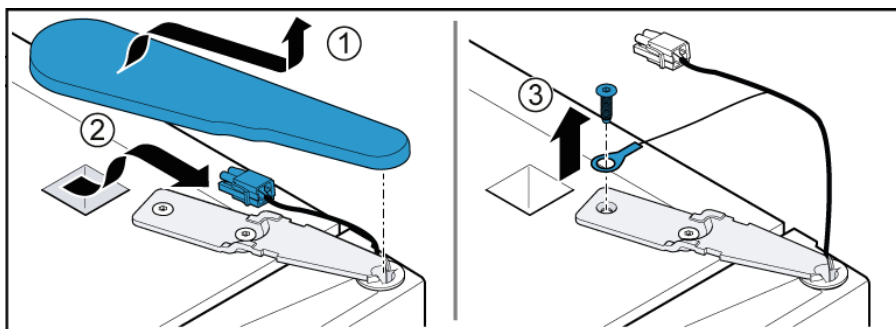

3. 1. Vyšroubujte šroub (1).
2. Vyjměte horní závěs (2).

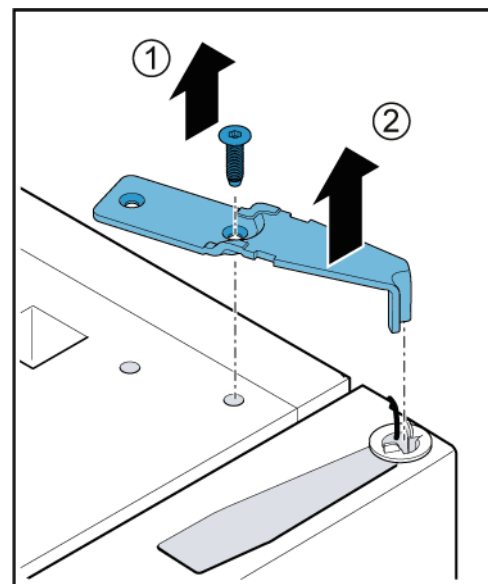

4. Vyměte horní dvířka.

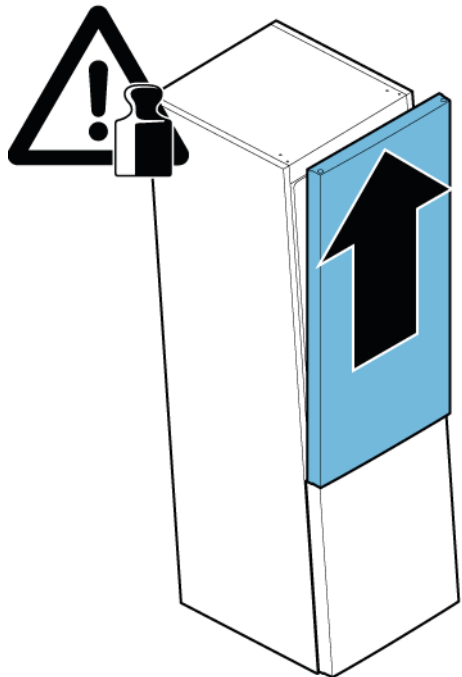

 Horní závěs je vyjmutý.

4.4.2 Montáž horního závěsu

- ▶ Montáž proveďte v opačném sledu.

4.5 Výměna středního závěsu dvířek

Speciální nástroje:

 Torx Bit TX20 6,3 mm (1/4") [00340865]

	⚠ VÝSTRAHA
	<p>Těžké, objemné spotřebiče! Poranění zad a svalů</p> <ul style="list-style-type: none"> ▶ Odstranění dvířek spotřebiče by měl provádět výhradně školený odborník. ▶ Pro manipulaci se spotřebičem jsou nutní dva lidé. ▶ Použijte pouze vhodné nástroje a zařízení.



	⚠ POZOR
	<p>Ostré hrany! Nebezpečí řezných poranění</p> <ul style="list-style-type: none"> ▶ Používejte ochranné rukavice.

	⚠ VÝSTRAHA
	<p>Sklouznutí nakloněných spotřebičů! Zlomeniny / poranění rozdrcením</p> <ul style="list-style-type: none"> ▶ Zajistěte spotřebiče proti sklouznutí.

	⚠ POZOR
	<p>Nebezpečí padajících dílů kvůli uvolněným šroubům! Poranění padajícími díly.</p> <ul style="list-style-type: none"> ▶ Zajistěte jednotlivé součásti před pádem.

	POZOR!
	<p>Nebezpečí padajících dílů kvůli uvolněným šroubům! Poškození jiných částí spotřebiče nebo prvků domácnosti zákazníka, např. podlahy.</p> <ul style="list-style-type: none"> ▶ Zajistěte jednotlivé součásti před pádem.

Požadavek:

-  Spotřebič je odpojený od přívodu elektrické energie.
-  Vnitřní kování spotřebiče je vyjmuté.
-  Horní závěs dvířek je vyjmutý.

 Horní dvířka jsou vyjmutá.

4.5.1 Vyjmutí středního závěsu dvířek

1. 1. Vyšroubujte dva šrouby (1).
2. 2. Vyjměte střední závěs (2).

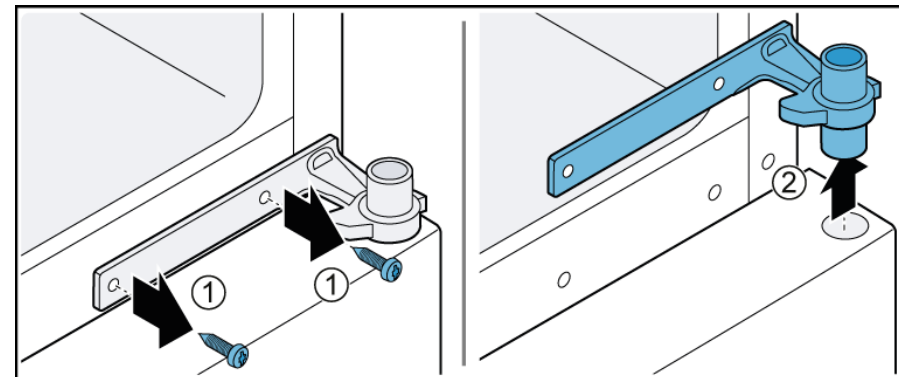

2. Vyměte dolní dvířka.

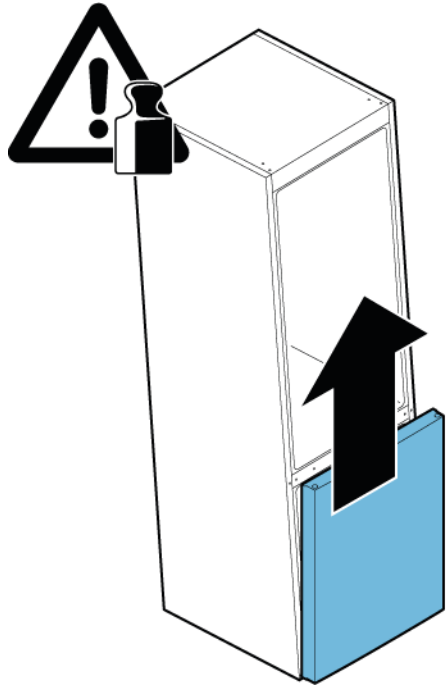

➡ Střední závěs je vyjmutý.

4.5.2 Montáž středního závěsu dvířek

▶ Montáž proveďte v opačném sledu.

4.6 Výměna dolního závěsu dvířek

Speciální nástroje:

Torx Bit TX20 6,3 mm (1/4") [00340865]

	⚠ VÝSTRAHA
	<p>Těžké, objemné spotřebiče! Poranění zad a svalů</p> <ul style="list-style-type: none"> ▶ Odstranění dvířek spotřebiče by měl provádět výhradně školený odborník. ▶ Pro manipulaci se spotřebičem jsou nutní dva lidé. ▶ Použijte pouze vhodné nástroje a zařízení.

	⚠ POZOR
	<p>Ostré hrany! Nebezpečí řezných poranění</p> <ul style="list-style-type: none"> ▶ Používejte ochranné rukavice.

	⚠ VÝSTRAHA
	<p>Sklouznutí nakloněných spotřebičů! Zlomeniny / poranění rozdrcením</p> <ul style="list-style-type: none"> ▶ Zajistěte spotřebiče proti sklouznutí.

	⚠ POZOR
	<p>Nebezpečí padajících dílů kvůli uvolněným šroubům! Poranění padajícími díly.</p> <ul style="list-style-type: none"> ▶ Zajistěte jednotlivé součásti před pádem.

	POZOR!
	<p>Nebezpečí padajících dílů kvůli uvolněným šroubům! Poškození jiných částí spotřebiče nebo prvků domácnosti zákazníka, např. podlahy.</p> <ul style="list-style-type: none"> ▶ Zajistěte jednotlivé součásti před pádem.

Požadavek:

- ✔ Spotřebič je odpojený od přívodu elektrické energie.
- ✔ Vnitřní kování spotřebiče je odstraněno.
- ✔ Horní závěs je vyjmutý.

✔ Střední závěs je vyjmutý.

4.6.1 Vyjmutí spodního závěsu dvířek

- ▶ 1. Vyšroubujte dva šrouby (1).
- ▶ 2. Vyjměte spodní závěs (2).

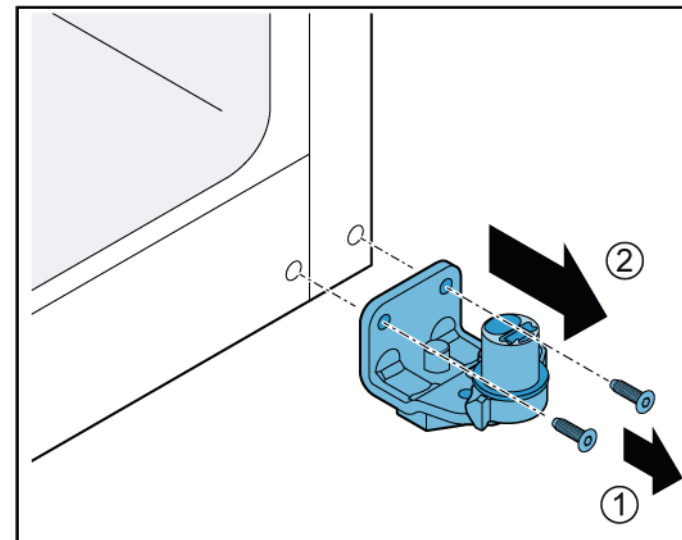

➡ Spodní závěs dvířek je vyjmutý.

4.6.2 Montáž spodního závěsu dvířek

- ▶ Montáž proveďte v opačném sledu.

4.7 Výměna odkládací plochy

Požadavek:

- ✔ Dvířka jsou otevřená.

4.7.1 Vyjmutí odkládací plochy

- ▶ 1. Zvedněte vzadu odkládací plochu (1).
- ▶ 2. Odkládací plochu (2) uvolněte.

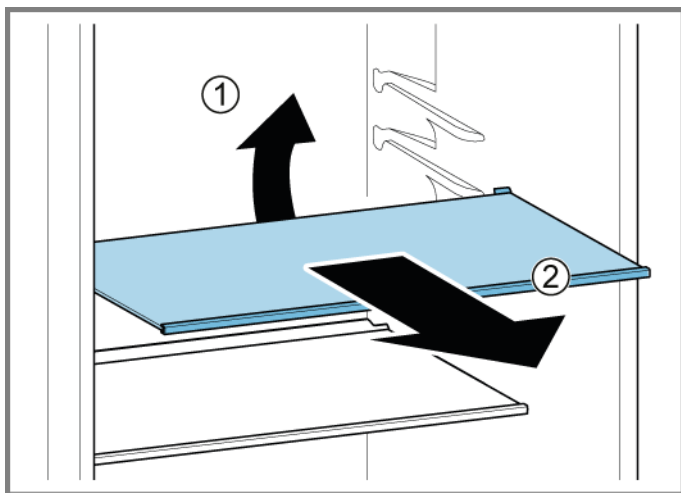

- ➡ Odkládací plocha je vyjmutá.

4.7.2 Montáž odkládací plochy

- ▶ Montáž proveďte v opačném sledu.

4.8 Výměna držáku na láhve

Požadavek:

- ✔ Dvířka jsou otevřená.

4.8.1 Vyjmutí držáku na láhve

- ▶ Vytáhněte držák na láhve.

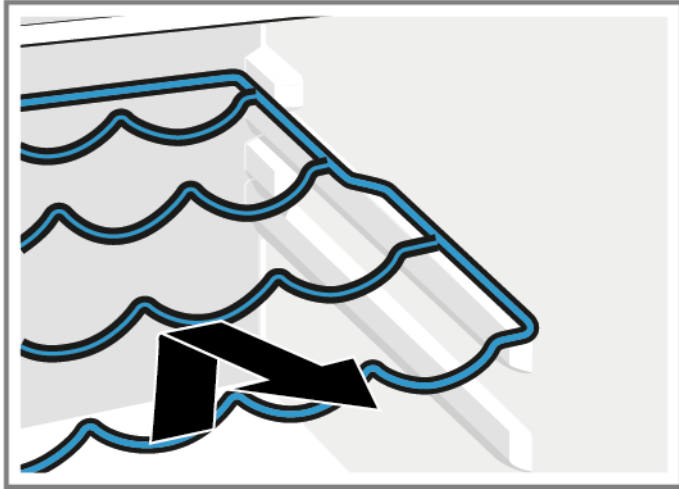

- ➡ Držák na láhve je vyjmutý.

4.8.2 Montáž držáku na láhve

- ▶ Montáž provedte v opačném sledu.

4.9 Výměna dveřní přihrádky

Požadavek:

- ✔ Dvířka jsou otevřená.

4.9.1 Vyjmutí dveřní přihrádky

- ▶ Zvedněte dveřní přihrádku nahoru.

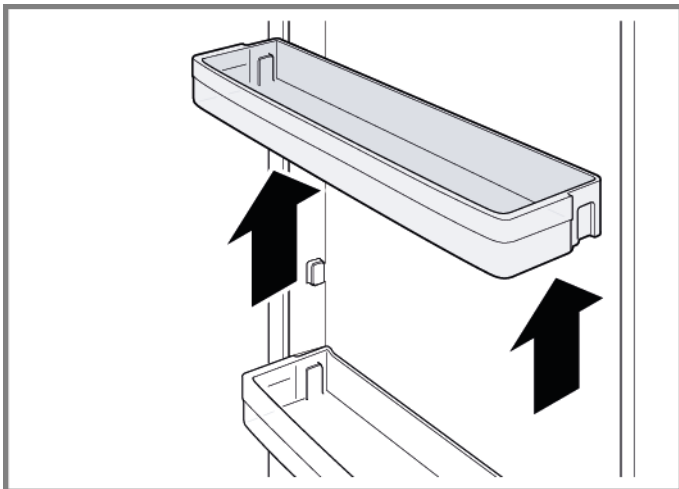

- ➡ Dveřní přihrádka je vyjmutá.

4.9.2 Montáž dveřní přihrádky

- ▶ Montáž proveďte v opačném sledu.

4.10 Výměna zásobníku

Požadavek:

- ✔ Dvířka jsou otevřená.

4.10.1 Vyjmutí zásobníku

1. Co nejvíce vytáhněte zásobník.
2. 1. Zásobník vpředu zvedněte (1).
2. Vyjměte zásobník (2).

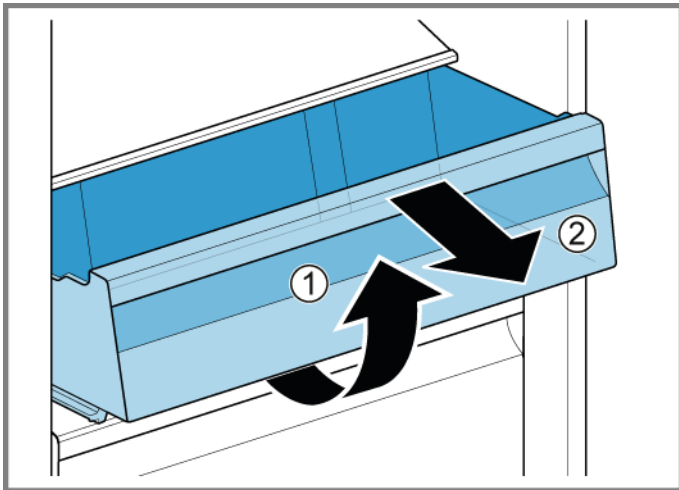

- ➡ Zásobník je vyjmutý.

4.10.2 Montáž zásobníku

- ▶ Montáž proveďte v opačném sledu.

4.11 Výměna zásobníku na ovoce a zeleninu

Požadavek:

- ✔ Dvířka jsou otevřená.

4.11.1 Vyjmutí zásobníku na ovoce a zeleninu

1. Co nejvíce vytáhněte zásobník na ovoce a zeleninu.
2. 1. Zvedněte vpředu (1) zásobník na ovoce a zeleninu.
2. Vyjměte zásobník (2).

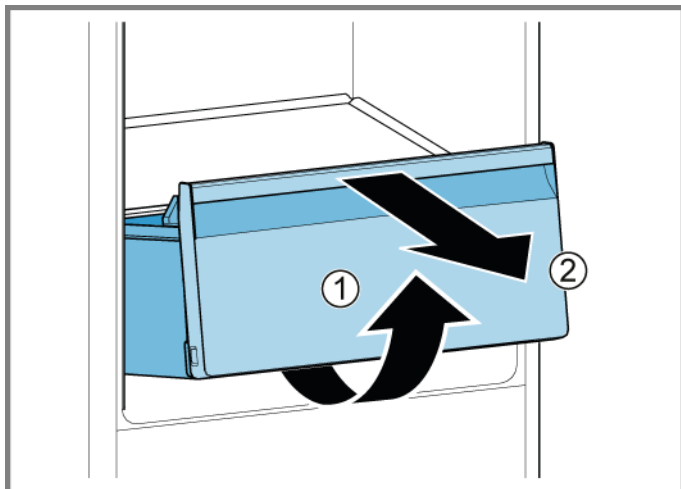

- ➔ Zásobník na ovoce a zeleninu je vyjmutý.

4.11.2 Montáž zásobníku na ovoce a zeleninu

- ▶ Montáž proveďte v opačném sledu.

4.12 Výměna odkládací plochy nad zásobníkem na ovoce a zeleninu

Požadavek:

- ✓ Dvířka jsou otevřená.
- ✓ [Zásobník na ovoce a zeleninu je vyjmutý. →83](#)

4.12.1 Vyjmutí odkládací plochy nad zásobníkem na ovoce a zeleninu

1. Zatlačte těsnicí rám nahoru a ven.

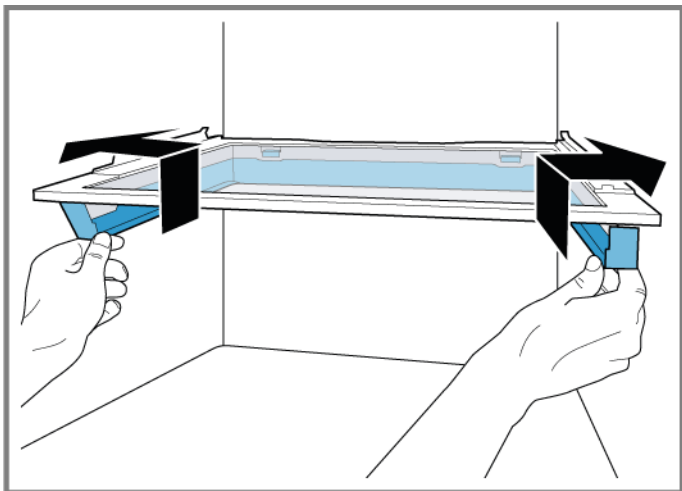

- ➡ Boční háky jsou uvolněné.

2. Zvedněte těsnicí rám a posuňte jej dozadu.

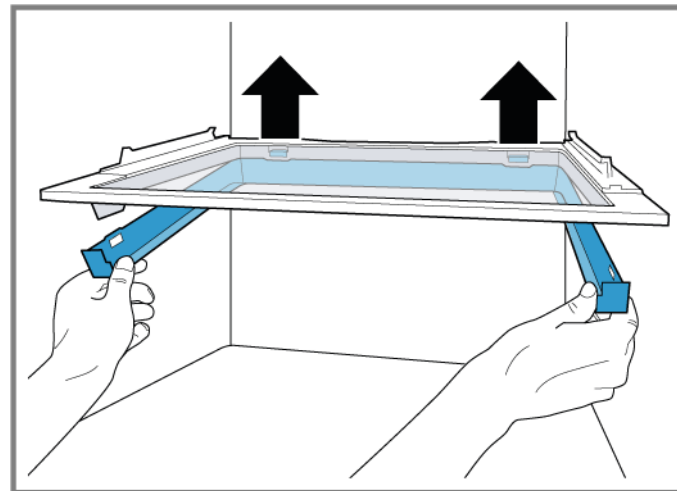

- ➡ Zadní háky jsou uvolněné.

3. Vyjměte těsnicí rám.
4. Zvedněte odkládací plochu nad zásobníkem na ovoce a zeleninu a vytočte ji do strany.

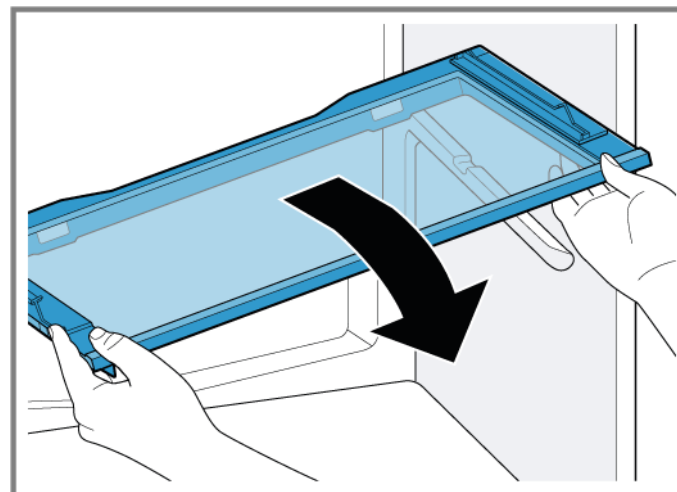

- ➡ Odkládací plocha nad zásobníkem na ovoce a zeleninu je vyjmutá.

4.12.2 Montáž odkládací plochy nad zásobníkem na ovoce a zeleninu

- ▶ Montáž proveďte v opačném sledu.

4.13 Výměna zásobníku na zmrazené potraviny

Požadavek:

- ✔ Dvířka jsou otevřená.

4.13.1 Vyjmutí zásobníku na zmrazené potraviny

- ▶ 1. Úplně vytáhněte zásobník na zmrazené potraviny (1).
- ▶ 2. Vyjměte zásobník na potraviny (2).

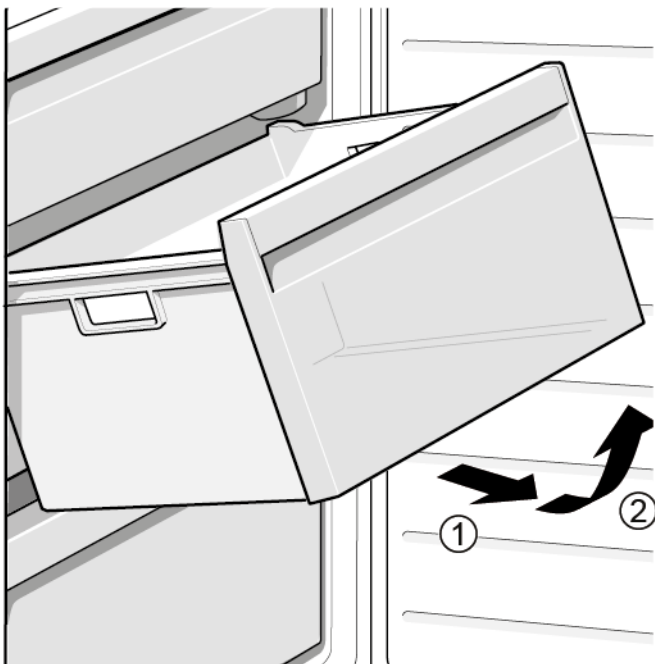

- ➡ Zásobník na zmrazené potraviny je vyjmutý.

4.13.2 Montáž zásobníku na zmrazené potraviny

- ▶ Montáž proveďte v opačném sledu.

4.14 Výměna horního LED osvětlení

Speciální nástroje:

Speciální nástroj [00342180]



Váš spotřebič je vybaven bezúdržbovým LED osvětlením.
Tato osvětlení smí být opravena pouze zákaznickým servisem nebo oprávněným technikem!



NEBEZPEČÍ

Nebezpečí úrazu elektrickým proudem při dotyku dílů pod proudem!
V případě neodborné opravy hrozí nebezpečí smrtelného úrazu elektrickým proudem

- ▶ Opravu elektrického zařízení smí provádět jen kvalifikovaný elektrikář.
- ▶ Po opravě nechte provést bezpečnostní zkoušku podle VDE 0701 nebo specifických předpisů dané země.



NEBEZPEČÍ

Nebezpečí úrazu elektrickým proudem při dotyku dílů pod proudem!
Usmrcení elektrickým proudem

- ▶ Odpojte spotřebič od přívodu elektrického proudu alespoň 60 sekund před zahájením opravy.



POZOR

Ostré hrany!
Nebezpečí řezných poranění

- ▶ Používejte ochranné rukavice.

Požadavek:

- ✔ Spotřebič je odpojený od přívodu elektrické energie.
- ✔ Dvířka jsou otevřená.

4.14.1 Demontáž horního LED osvětlení

1. Zasuňte nástroj pro demontáž mezi horní LED osvětlení a vnitřní vložku chladicího prostoru, abyste uvolnili háky (1).
2. Vyjměte horní LED osvětlení (2).

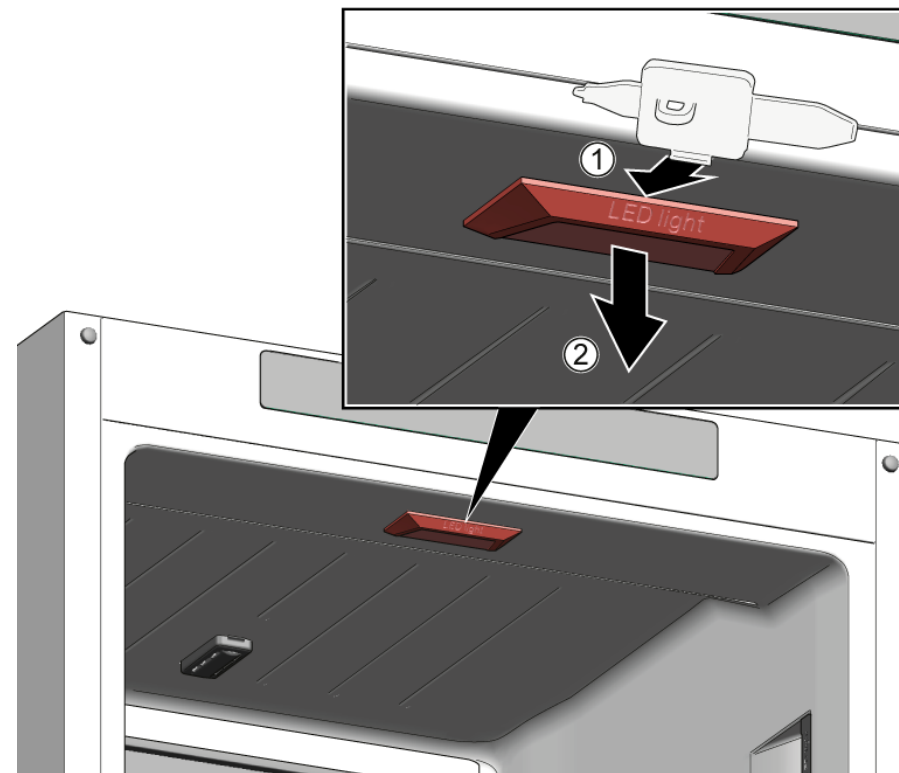

2. Odpojte elektrické připojení horního LED osvětlení.
- ➡ Horní LED osvětlení je vyjmuté.

4.14.2 Montáž horního LED osvětlení

- ▶ Montáž proveďte v opačném sledu.

4.15 Výměna bočního LED osvětlení

Speciální nástroje:

 Speciální nástroj [00342180]

 Váš spotřebič je vybaven bezúdržbovým LED osvětlením. Tato osvětlení smí být opravena pouze zákaznickým servisem nebo oprávněným technikem!

 **NEBEZPEČÍ**
Nebezpečí úrazu elektrickým proudem při dotyku dílů pod proudem!
 V případě neodborné opravy hrozí nebezpečí smrtelného úrazu elektrickým proudem

- ▶ Opravu elektrického zařízení smí provádět jen kvalifikovaný elektrikář.
- ▶ Po opravě nechte provést bezpečnostní zkoušku podle VDE 0701 nebo specifických předpisů dané země.

 **NEBEZPEČÍ**
Nebezpečí úrazu elektrickým proudem při dotyku dílů pod proudem!
 Usmrcení elektrickým proudem

- ▶ Odpojte spotřebič od přívodu elektrického proudu alespoň 60 sekund před zahájením opravy.



 **POZOR**
Ostré hrany!
 Nebezpečí řezných poranění

- ▶ Používejte ochranné rukavice.

 **POZOR!**
Nebezpečí poškození elektrostaticky citlivých součástí (elektrostatický výboj)!
 Poškození součástí

- ▶ Předtím, než se dotknete elektrostaticky citlivých součástí, použijte elektrostatický ochranný systém (ochrannou zemnicí zástrčku).
- ▶ Nedotýkejte se přípojek a vodičů modulů.
- ▶ Elektrostaticky citlivé součásti přepravujte pouze ve vodivých materiálech nebo originálním balení.
- ▶ Elektrostaticky citlivé součásti udržujte mimo materiály schopné elektrostatického nabití (např. plasty).

Požadavek:

-  Spotřebič je odpojený od přívodu elektrické energie.
-  Dvířka jsou otevřená.
-  Vnitřní kování chladničky je vyjmuté.

4.15.1 Demontáž bočního LED osvětlení

1. Pro uvolnění háku zasuňte nástroj pro demontáž mezi difuzor osvětlení a kryt (1).
2. Odeberte difuzor osvětlení (2).
3. Stejným způsobem uvolněte jednotlivé upevňovací háky difuzoru.

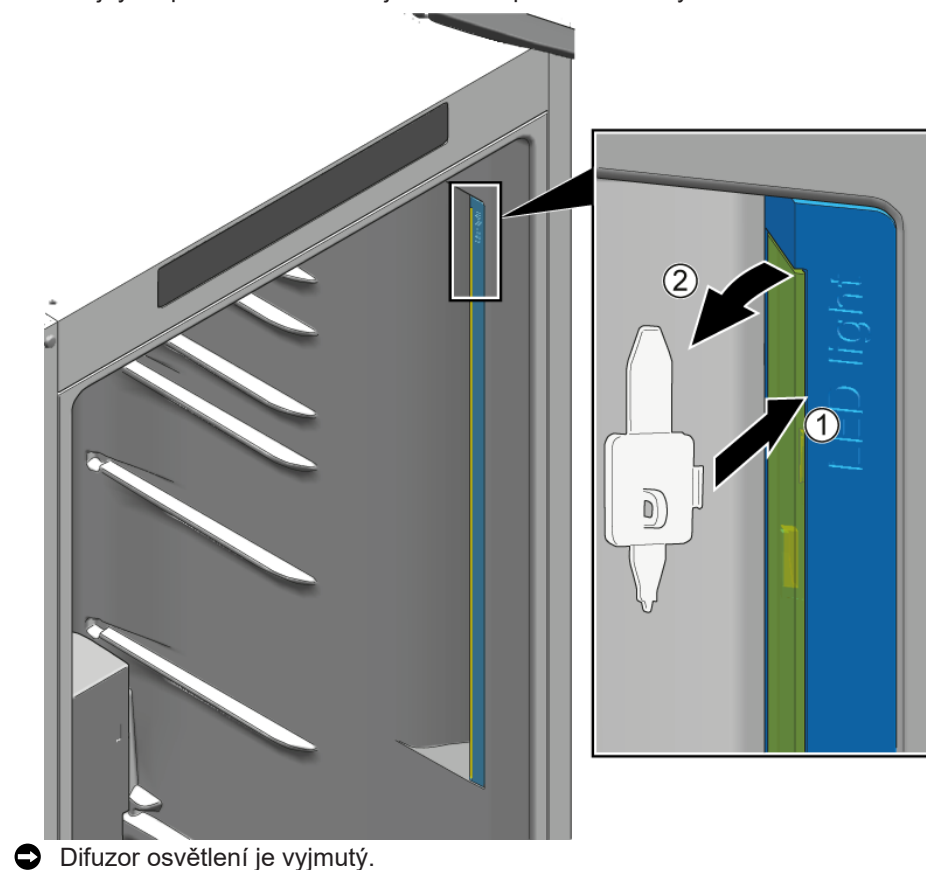

1. Stiskněte upevňovací hák, abyste ho uvolnili (1).
2. Posuňte LED modul nahoru cca o 1 cm, a odstraňte a odpojte jej tak z elektrické zásuvky (2).
3. Vyměňte LED moduly (3).

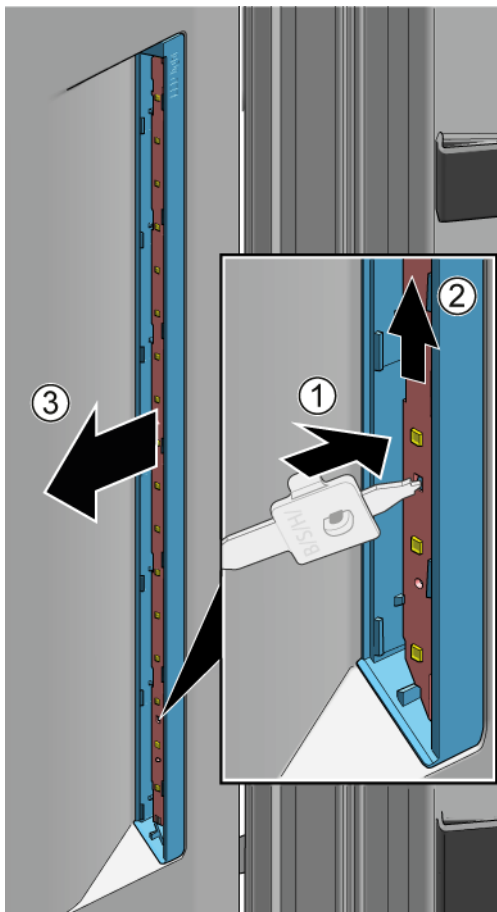

 Boční LED osvětlení je vyjmuté.

4.15.2 Montáž bočního LED osvětlení



Protože se háky difuzoru osvětlení během demontáže snadno zlomí, obsahuje sada náhradních dílů bočního LED osvětlení také LED modul a difuzor osvětlení.

1. Pro uvolnění háku zasuňte nástroj pro demontáž mezi difuzor osvětlení a kryt (1).
2. Odeberte difuzor osvětlení (2).
3. Stejným způsobem uvolněte jednotlivé upevňovací háky difuzoru.

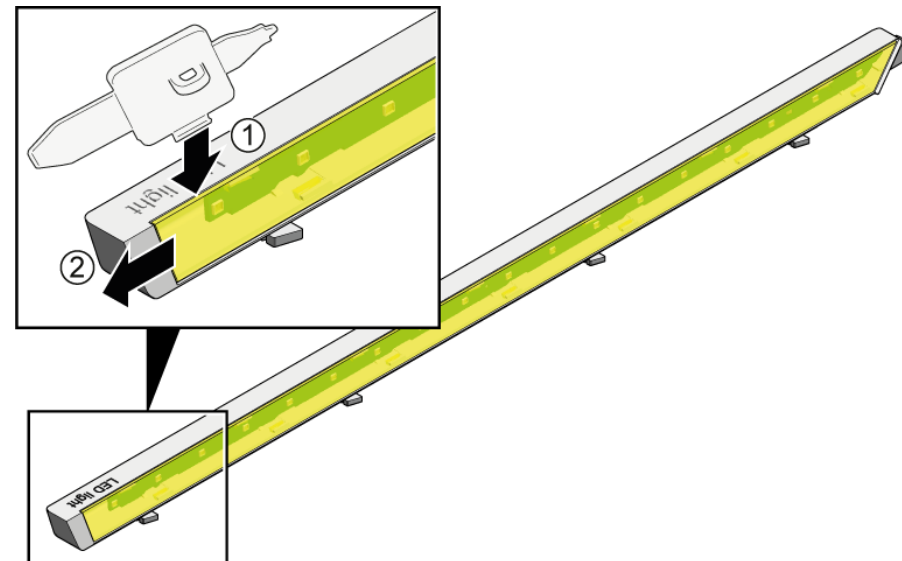

Oprava

1. Stiskněte upevňovací hák, abyste ho uvolnili (1).
2. Posuňte LED modul směrem nahoru ven z pouzdra.
3. Odstraňte pouzdro LED modulu, které se používá z bezpečnostních důvodů při přepravě náhradních dílů (3).

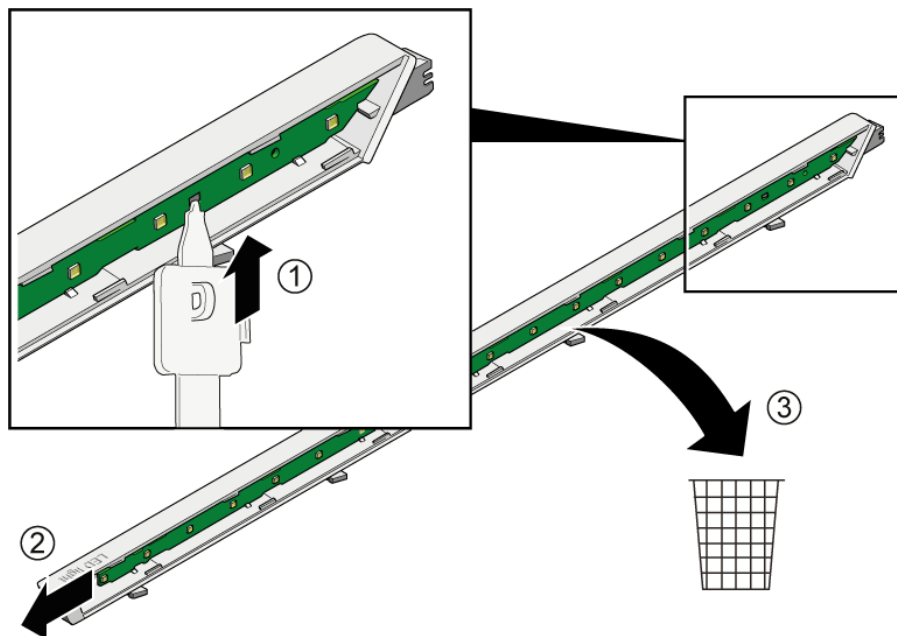

3. Proved'te montáž LED modulu a difuzoru osvětlení v opačném sledu, než jste je odstraňovali.

4.16 Výměna LED osvětlení v mrazničce

Speciální nástroje:

 Speciální nástroj [00342180]

 Váš spotřebič je vybaven bezúdržbovým LED osvětlením. Tato osvětlení smí být opravena pouze zákaznickým servisem nebo oprávněným technikem!

 **NEBEZPEČÍ**
Nebezpečí úrazu elektrickým proudem při dotyku dílů pod proudem!
 V případě neodborné opravy hrozí nebezpečí smrtelného úrazu elektrickým proudem

- ▶ Opravu elektrického zařízení smí provádět jen kvalifikovaný elektrikář.
- ▶ Po opravě nechte provést bezpečnostní zkoušku podle VDE 0701 nebo specifických předpisů dané země.



 **NEBEZPEČÍ**
Nebezpečí úrazu elektrickým proudem při dotyku dílů pod proudem!
 Usmrcení elektrickým proudem

- ▶ Odpojte spotřebič od přívodu elektrického proudu alespoň 60 sekund před zahájením opravy.

 **POZOR**
Ostré hrany!
 Nebezpečí řezných poranění

- ▶ Používejte ochranné rukavice.



Požadavek:

-  Spotřebič je odpojený od přívodu elektrické energie.
-  Dvířka jsou otevřená.

4.16.1 Demontáž LED osvětlení v mrazničce

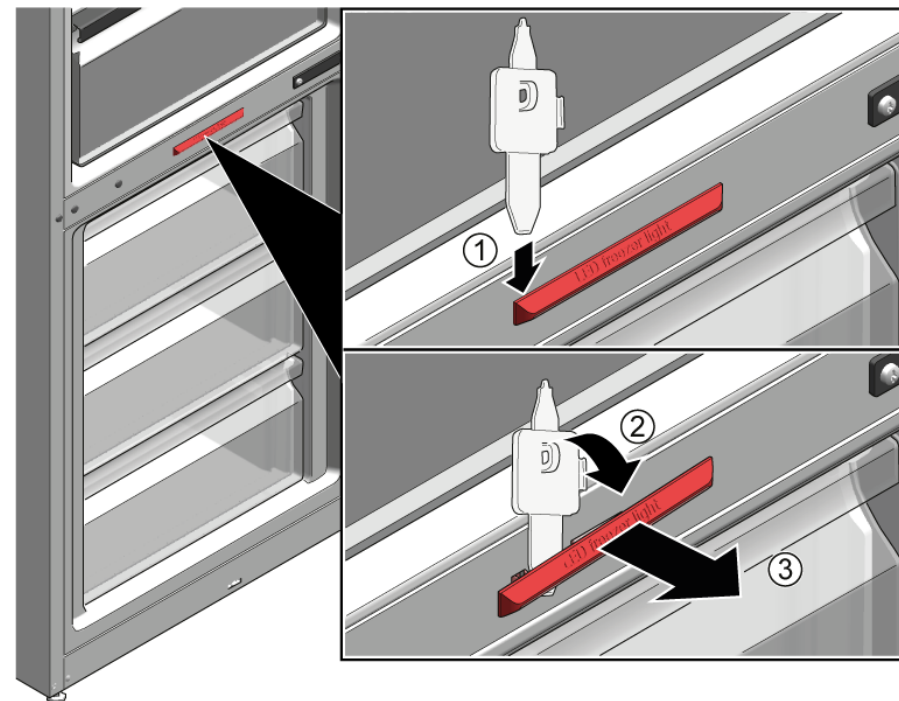
- ▶ 1. Zasuňte nástroj pro demontáž mezi osvětlení a kryt na boční straně osvětlení tak, aby vznikla mezera (1).
- ▶ 2. Posuňte nástroj pro demontáž na druhou stranu upevňovacího háku osvětlení a otočte jej dopředu (2).
- ▶ 3. Vyjměte LED osvětlení mrazničky (3).







-  LED osvětlení mrazničky je odpojené.
-  LED osvětlení mrazničky je vyjmuté.

4.16.2 Montáž LED osvětlení mrazničky

- ▶ Montáž proveďte v opačném sledu.

Tip til reparation - Køle-/ frysekombination

 Om dette dokument	93
1.1 Vigtig information.....	93
1.1.1 Formål.....	93
1.2 Forklaring af symboler	93
1.2.1 Fareniveauer	93
1.2.2 Faresymboler.....	93
1.2.3 Advarslernes opbygning	94
1.2.4 Generelle symboler	94
 Sikkerhed	95
2.1 Generelle sikkerhedsanvisninger	95
2.1.1 Alle husholdningsapparater	95
 Værktøjer og hjælpemidler	96
 Reparation	97
4.1 Udskiftning af dørpakning.....	97
4.1.1 Fjernelse af dørpakning.....	97
4.1.2 Montering af dørpakning.....	97
4.2 Udskiftning af dørhåndtag	100
4.2.1 Fjernelse af dørhåndtag	100
4.2.2 Montering af dørhåndtag	100
4.3 Udskiftning af øverste dørhængsel	101
4.3.1 Fjernelse af øverste dørhængsel.....	101
4.3.2 Montering af øverste dørhængsel	102
4.4 Udskiftning af det øverste dørhængsel (dør med display).....	103
4.4.1 Fjernelse af øverste dørhængsel.....	103
4.4.2 Montering af øverste dørhængsel	104
4.5 Udskiftning af midterste dørhængsel.....	105
4.5.1 Fjernelse af midterste dørhængsel	105
4.5.2 Montering af midterste dørhængsel.....	106
4.6 Udskiftning af nederste dørhængsel	107
4.6.1 Fjernelse af nederste dørhængsel.....	107
4.6.2 Montering af nederste dørhængsel.....	107
4.7 Udskiftning af hylde	108
4.7.1 Fjernelse af hylde.....	108
4.7.2 Montering af hylde	108

4.8 Udskiftning af flaskehylde	109
4.8.1 Fjernelse af flaskehylde	109
4.8.2 Montering af flaskehylde	109
4.9 Udskiftning af dørhylde.....	110
4.9.1 Fjernelse af dørhylde	110
4.9.2 Montering af dørhylde	110
4.10 Udskiftning af opbevaringsbeholder	111
4.10.1 Fjernelse af opbevaringsbeholder.....	111
4.10.2 Installation af opbevaringsbeholder.....	111
4.11 Udskiftning af frugt- og grøntsagsbeholder	112
4.11.1 Fjernelse af frugt- og grøntsagsbeholder.....	112
4.11.2 Montering af frugt- og grøntsagsbeholder.....	112
4.12 Udskiftning af hylde over frugt- og grøntsagsbeholderen	113
4.12.1 Fjernelse af hylde over frugt- og grøntsagsbeholderen.....	113
4.12.2 Montering af hylde over frugt- og grøntsagsbeholderen	114
4.13 Udskiftning af frostvarebeholder.....	115
4.13.1 Fjernelse af frostvarebeholder	115
4.13.2 Montering af frostvarebeholder	115
4.14 Udskiftning af LED-toplampe	116
4.14.1 Afmontering af LED-toplampe	116
4.14.2 Installation af LED-toplampe	116
4.15 Udskiftning af LED-sidelygte	117
4.15.1 Afmontering af LED-sidelygte	117
4.15.2 Montering af LED-sidelygte	118
4.16 Udskiftning af LED-fryselampe	120
4.16.1 Fjernelse af LED-fryselampe	120
4.16.2 LED-fryselampen er fjernet.....	120

i Om dette dokument

1.1 Vigtig information

1.1.1 Formål

Disse reparationsanvisninger hjælper kunden til selv at kunne reparere apparater i henhold til den gældende lovgivning om miljøvenligt design (fra 03/2021).





De indeholder information om, hvordan der udskiftes bestemte reservedele, herunder advarsler og risici.

Kontakt kundeservice i tilfælde af spørgsmål. Vi påtager os kun ansvar for skader, hvis reparationsanvisningerne er fuldt korrekt.

1.2 Forklaring af symboler

1.2.1 Fareniveauer

Advarselsniveauerne består af et symbol og et signalford. Signalfordene indikerer farens alvor.





Advarselsniveau	Betydning
	Manglende overholdelse af advarselsmeddelelsen vil medføre død eller alvorlige kvæstelser.
	Manglende overholdelse af advarselsmeddelelsen kan medføre død eller alvorlige kvæstelser.
	Manglende overholdelse af advarselsmeddelelsen kan medføre mindre kvæstelser.
	Manglende overholdelse af advarselsmeddelelsen kan medføre materiel beskadigelse.

Tabel 1: Fareniveauer





1.2.2 Faresymboler

Faresymboler er symbolske visninger, der giver en indikation af faretypen.

Der anvendes følgende faresymboler i dette dokument:

Faresymbol	Betydning
	Generel advarselsmeddelelse
	Fare for elektrisk spænding
	Eksplussionsfare
	Fare for at skære sig

i Om dette dokument

Faresymbol	Betydning
	Fare for klemning
	Fare pga. varme overflader
	Fare pga. kraftigt magnetfelt
	Fare pga. ikke-ioniserende stråling

Tabel 2: Faresymboler

1.2.3 Advarslernes opbygning

Advarsler i dette dokument har et standardiseret udseende og en standardiseret opbygning.

	<p>FARE</p> <p>Farens type og kilde! Mulige følger, hvis faren/advarslen ignoreres.</p> <ul style="list-style-type: none"> ▶ Foranstaltninger og forbud for at forhindre faren.
--	---

De følgende eksempler viser en advarsel, der advarer mod elektrisk stød pga. spændingsførende dele. Foranstaltningen til at undgå faren er nævnt.

	<p>FARE</p> <p>Fare for elektrisk stød pga. spændingsførende dele! Død ved elektrisk stød</p> <ul style="list-style-type: none"> ▶ Afbryd apparater fra strømforsyningen i mindst 60 sekunder, før reparationer påbegyndes.
--	---

1.2.4 Generelle symboler

Der anvendes følgende generelle symboler i dette dokument:

Generelt symbol	Betydning
	Angivelse af et særligt tip (tekst og/eller grafik)
	Angivelse af et simpelt tip (kun tekst)
	Angivelse af et link til en videotutorial
	Angivelse af nødvendige værktøjer
	Angivelse af krævede forudsætninger
	Angivelse af en betingelse (hvis..., så...)
	Angivelse af et resultat
	Angivelse af en tast eller knap
	Angivelse af et materialenummer
	Angivelse af en vist tekst/et vist vindue (i apparatets display)

Tabel 3: Generelle symboler

2.1 Generelle sikkerhedsanvisninger

2.1.1 Alle husholdningsapparater

Fare for elektrisk stød pga. spændingsførende dele!

- Fejl i forbindelse med reparationer, der involverer elektriske komponenter, kan medføre elektrisk stød!
- Afbryd apparatet fra strømnettet i mindst 60 sekunder, før arbejdet påbegyndes.
- Få efter reparationen udført en sikkerhedstest i henhold til VDE 0701 eller landespecifikke forskrifter.

Fare for tilskadekomst pga. skarpe kanter!

- Brug beskyttelseshandsker.

Fare for klemning i forbindelse med reparation, vedligeholdelse, fejlafhjælpning og service på grund af tunge og bevægelige komponenter

- Brug sikkerhedssko.
- Sørg for at sikre tunge komponenter mod at falde ned.
- Stik kropsdele ind i bevægelige komponenter.

Fare for apparatets sikkerhed/funktion!

- Brug kun originale reservedele.

Fare for beskadigelse af elektrostatisk følsomme komponenter (elektrostatiske afladninger)!

- Berør ikke modulerne, herunder forbindelser og ledningsbaner.

Værktøjer og hjælpemidler

Betegnelse	Detaljer	Billeder
Torx-bit TX20 [00340865]	6,3 mm (1/4")	
Specialværktøj [00342180]		

4.1 Udskiftning af dørpakning

Preindstilling:

- ✔ Døren er åben.

4.1.1 Fjernelse af dørpakning

1. Frigør dørpakningen fra rillen i højre og venstre hjørne.

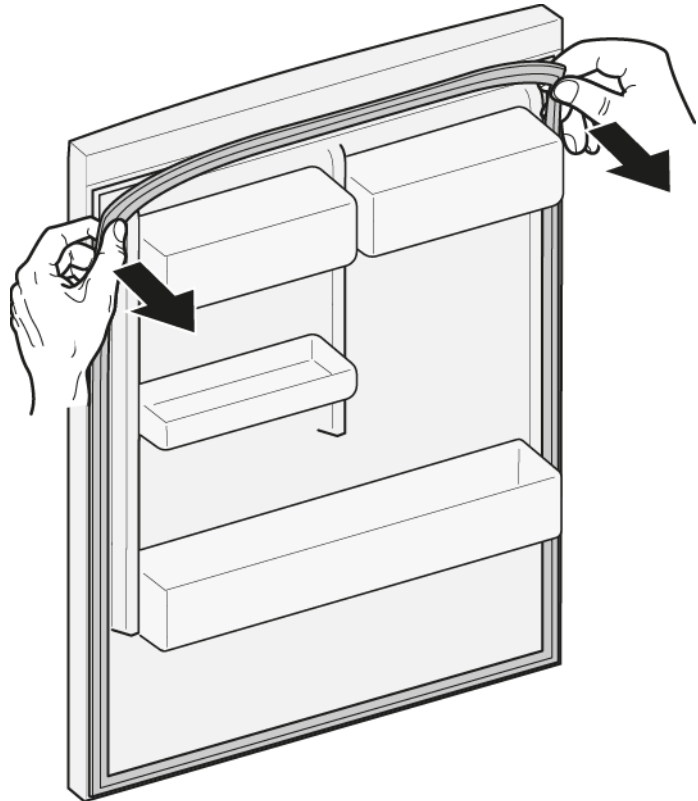

2. Træk dørpakningen ud af rillen.

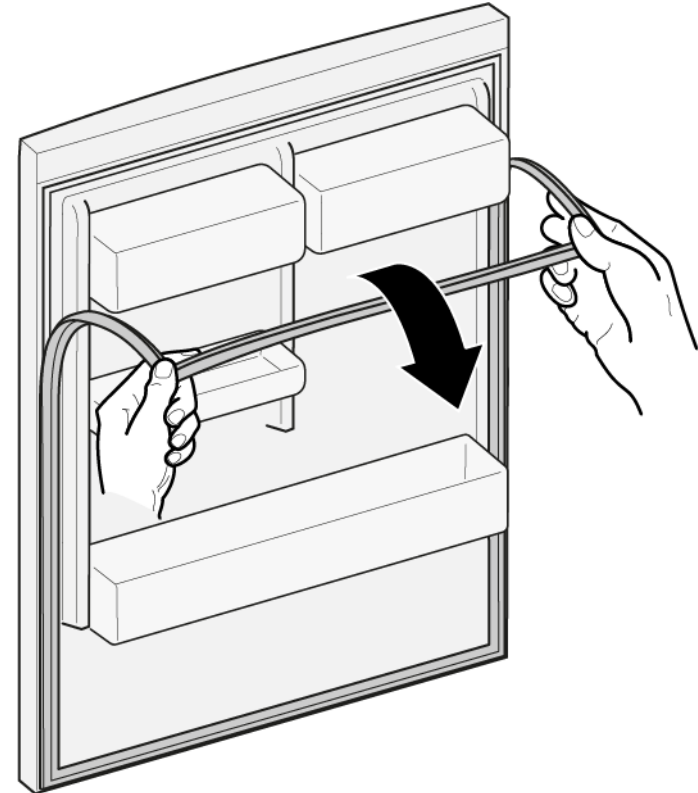

- ➡ Dørpakningen er fjernet.

4.1.2 Montering af dørpakning



Tykkelsen af den nye dørpakning kan afvige en smule fra tykkelsen af den gamle dørpakning. Dette vil ikke påvirke lukkemåden og den langsigtede funktion.

Hvis apparatet har justerbare hængsler eller hængselbeslag, kan lukkemåden efterfølgende optimeres.

Små sidehuller i dørpakningen er funktionelle (nødvendige til lufttilførelse). De er ikke produktionsfejl.

Reparation

1. Kontrollér rillen til pakningen med hensyn til beskadigelse.

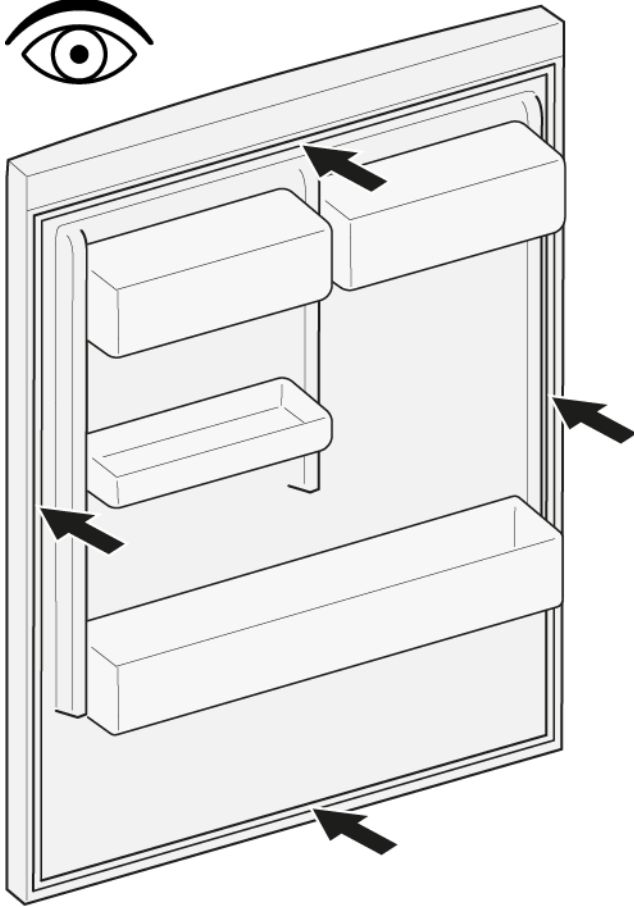

4. Tryk pakningens hjørner i rillen foroven og forneden.

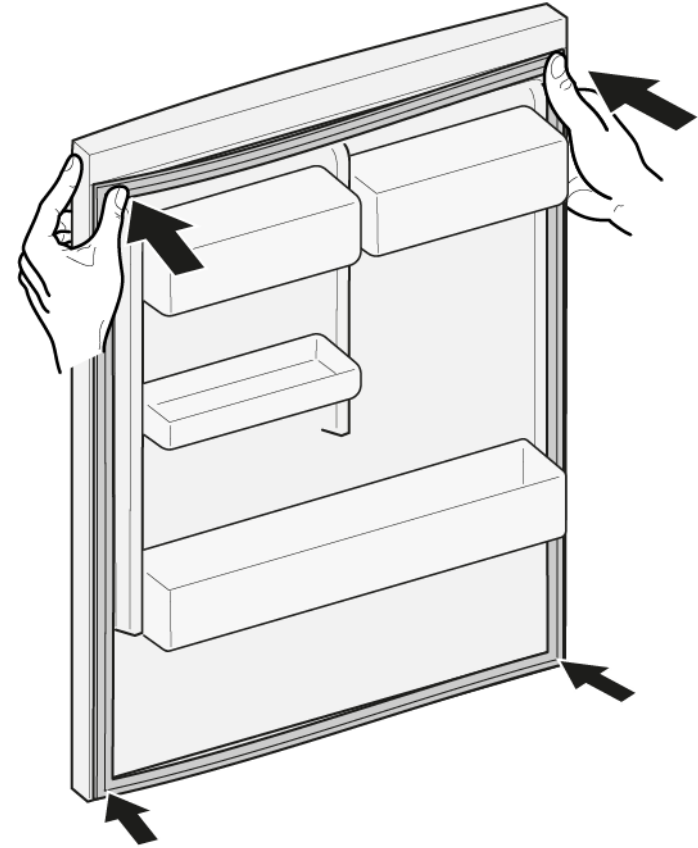

2.  Hvis rillen til pakningen er beskadiget:
 - Kontakt kundeservice.

3.  En smule deformation på dørpakningen er normalt og påvirker ikke dens funktion. Det anbefales til at glatte dørpakningen, før den sættes i apparatet.

Opvarm dørpakningen med en hårtørrer eller varmt vand, og genform den manuelt.

Reparation



5. Tryk hele pakningen trinvist i rillen.





 Dørpakningen er monteret.

4.2 Udskiftning af dørhåndtag

Nødvendig værktøj:

-  Torx-bit TX20 6,3 mm (1/4") [00340865]
-  Kærviskruetrækker Blad 10 mm x 1,6 mm x 200 mm

Preindstilling:

-  Apparatet er afbrudt fra strømforsyningen.
-  Døren er åben.

4.2.1 Fjernelse af dørhåndtag

- ▶ 1. Fjern de to skruehætter (1).
- ▶ 2. Skru de to skruer ud (2).
- ▶ 3. Fjern dørhåndtaget (3).

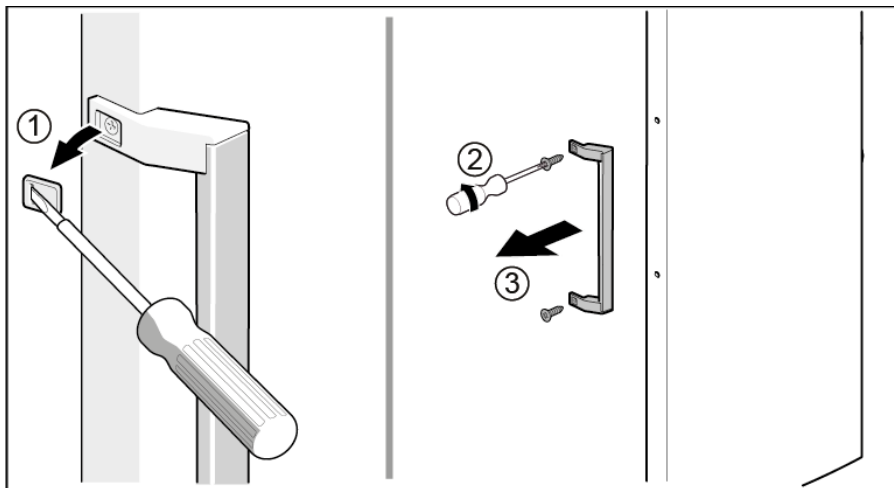

 Dørhåndtaget er fjernet.



Dørhåndtaget til den anden dør kan fjernes på samme måde.

4.2.2 Montering af dørhåndtag

- ▶ Montér i omvendt rækkefølge.

4.3 Udskiftning af øverste dørhængsel

Nødvendig værktøj:

Torx-bit TX20

6,3 mm (1/4")

[00340865]

	ADVARSEL
Tunge, store apparater!	
Ryg- og muskelskader	
<ul style="list-style-type: none"> ▶ Arbejde til fjernelse af apparatets dør bør kun udføres af uddannede specialister. ▶ Der skal være to personer om at flytte apparatet. ▶ Brug kun egnet værktøj og udstyr. 	



	PAS PÅ!
Skarpe kanter!	
Snitlæsioner	
<ul style="list-style-type: none"> ▶ Brug beskyttelseshandsker. 	

	ADVARSEL
Apparater på skrå kan glide!	
Knoglebrud/klemskader	
<ul style="list-style-type: none"> ▶ Sørg for at sikre apparater mod at glide. 	

	PAS PÅ!
Fare for nedfaldende dele pga. løsnede skruer!	
Personskade pga. nedfaldende dele.	
<ul style="list-style-type: none"> ▶ Sørg for at sikre komponenten mod at falde ned. 	

	BEMÆRK!
Fare for nedfaldende dele pga. løsnede skruer!	
Beskadigelse af andre apparatdele eller kundens hjem, f.eks. gulvet.	
<ul style="list-style-type: none"> ▶ Sørg for at sikre komponenten mod at falde ned. 	

Preindstilling:

-  Apparatet er afbrudt fra strømforsyningen.
-  Indvendigt tilbehør i apparatet er fjernet.

4.3.1 Fjernelse af øverste dørhængsel

1. Skub den bærende del ind under bundstykket.

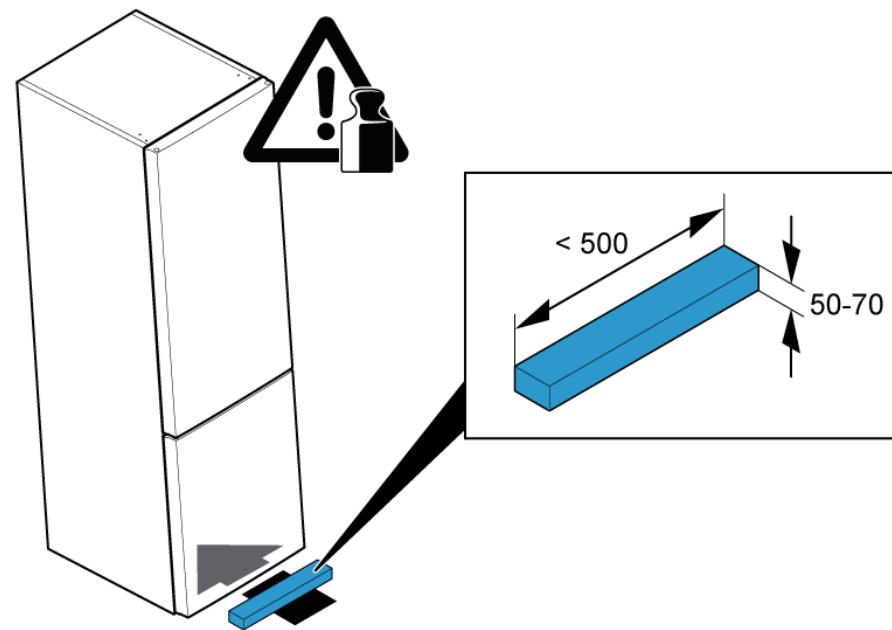

2.
 1. Fjern det øverste hængsels afdækning (1).
 2. Skru de to skruer ud (2).
 3. Fjern det øverste hængsel (3).

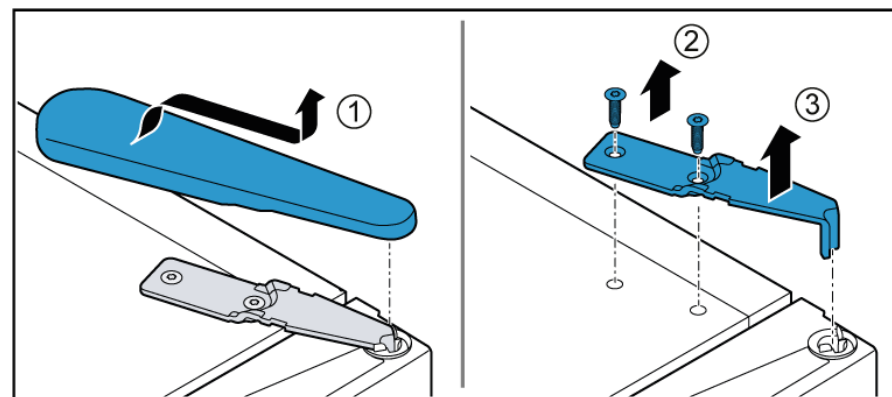

3. Fjern den øverste dør.

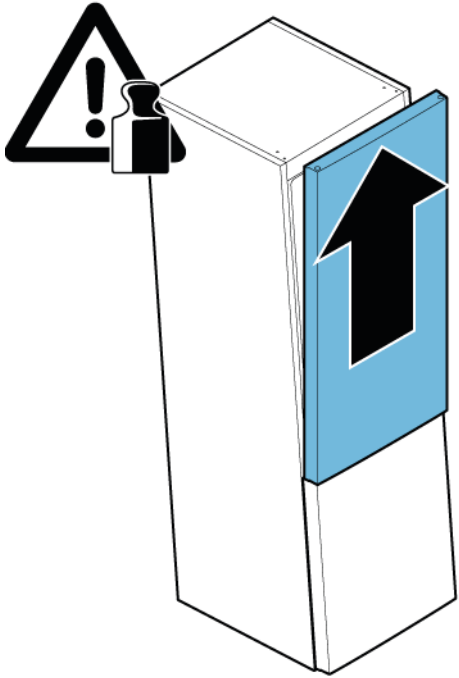

 Det øverste hængsel er fjernet.

4.3.2 Montering af øverste dørhængsel

▶ Montér i omvendt rækkefølge.

4.4 Udskiftning af det øverste dørhængsel (dør med display)

Nødvendig værktøj:

Torx-bit TX20 6,3 mm (1/4") [00340865]

	⚠ ADVARSEL
	<p>Tunge, store apparater! Ryg- og muskelskader</p> <ul style="list-style-type: none"> ▶ Arbejde til fjernelse af apparatets dør bør kun udføres af uddannede specialister. ▶ Der skal være to personer om at flytte apparatet. ▶ Brug kun egnet værktøj og udstyr.

	⚠ PAS PÅ!
	<p>Skarpe kanter! Snitlæsioner</p> <ul style="list-style-type: none"> ▶ Brug beskyttelseshandsker.

	⚠ ADVARSEL
	<p>Apparater på skrå kan glide! Knoglebrud/klemskader</p> <ul style="list-style-type: none"> ▶ Sørg for at sikre apparater mod at glide.

	⚠ PAS PÅ!
	<p>Fare for nedfaldende dele pga. løsnede skruer! Personskade pga. nedfaldende dele.</p> <ul style="list-style-type: none"> ▶ Sørg for at sikre komponenten mod at falde ned.

	BEMÆRK!
	<p>Fare for nedfaldende dele pga. løsnede skruer! Beskadigelse af andre apparatdele eller kundens hjem, f.eks. gulvet.</p> <ul style="list-style-type: none"> ▶ Sørg for at sikre komponenten mod at falde ned.

	⚠ FARE
	<p>Fare for elektrisk stød pga. spændingsførende dele! Livsfare pga. elektrisk stød i tilfælde af ukorrekt reparation</p> <ul style="list-style-type: none"> ▶ Elektriske dele skal repareres af kvalificerede elektrikere. ▶ Få efter reparationen udført en sikkerhedstest i henhold til VDE 0701 eller landespecifikke forskrifter.

	⚠ FARE
	<p>Fare for elektrisk stød pga. spændingsførende dele! Død ved elektrisk stød</p> <ul style="list-style-type: none"> ▶ Afbryd apparater fra strømforsyningen i mindst 60 sekunder, før reparationer påbegyndes.

Preindstilling:

- ✓ Apparatet er afbrudt fra strømforsyningen.
- ✓ Indvendigt tilbehør i apparatet er fjernet.

4.4.1 Fjernelse af øverste dørhængsel

1. Skub den bærende del ind under bundstykke.

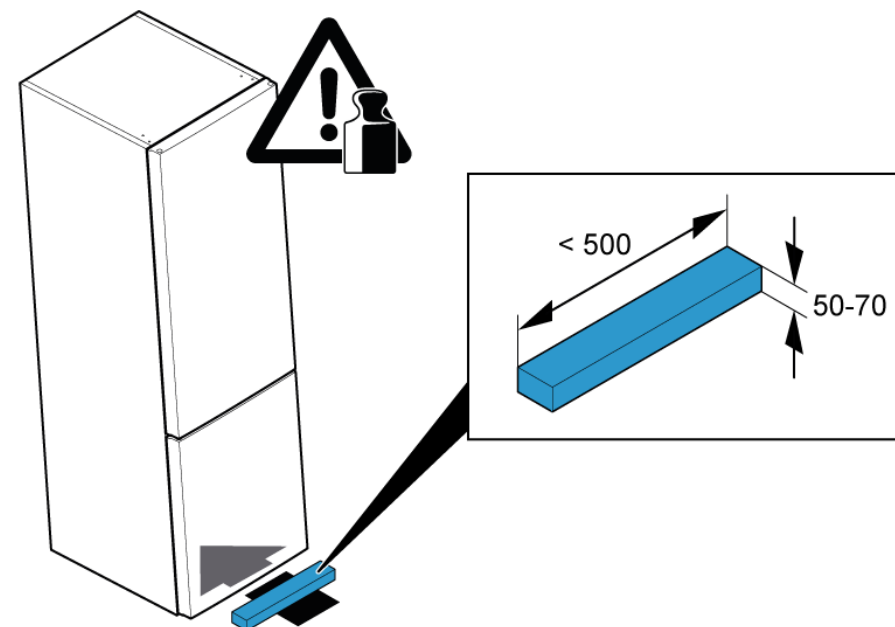

Reparation

1. Fjern det øverste hængsels afdækning (1).
2. Afbryd den elektriske tilslutning (2).
3. Skru jordforbindelsesskruen ud (3).

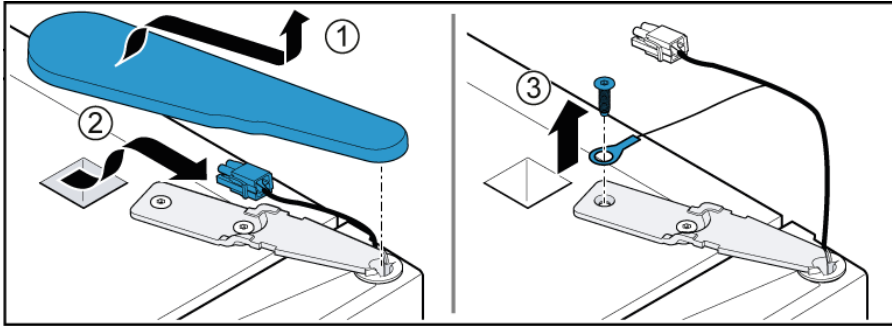

1. Skru skruen ud (1).
2. Fjern det øverste hængsel (2).

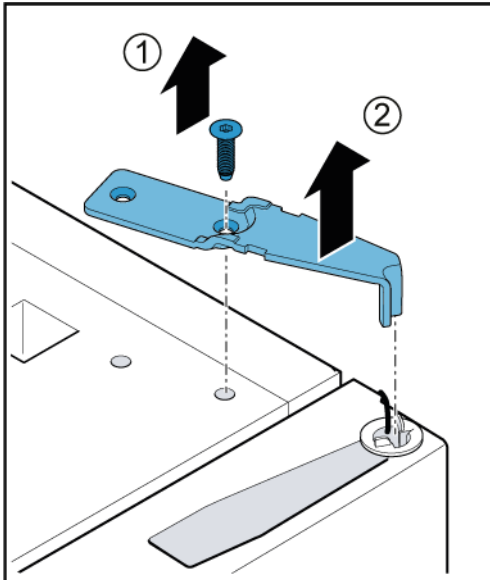

4. Fjern den øverste dør.

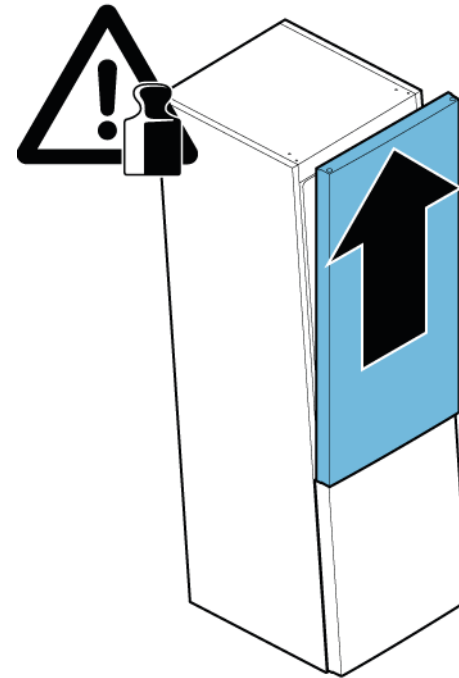

➡ Det øverste hængsel er fjernet.

4.4.2 Montering af øverste dørhængsel

- ▶ Montér i omvendt rækkefølge.

4.5 Udskiftning af midterste dørhængsel

Nødvendig værktøj:

🌀 Torx-bit TX20

6,3 mm (1/4")

[00340865]

	⚠ ADVARSEL
	<p>Tunge, store apparater! Ryg- og muskelskader</p> <ul style="list-style-type: none"> ▶ Arbejde til fjernelse af apparatets dør bør kun udføres af uddannede specialister. ▶ Der skal være to personer om at flytte apparatet. ▶ Brug kun egnet værktøj og udstyr.

	⚠ PAS PÅ!
	<p>Skarpe kanter! Snitlæsioner</p> <ul style="list-style-type: none"> ▶ Brug beskyttelseshandsker.

	⚠ ADVARSEL
	<p>Apparater på skrå kan glide! Knoglebrud/klemskader</p> <ul style="list-style-type: none"> ▶ Sørg for at sikre apparater mod at glide.

	⚠ PAS PÅ!
	<p>Fare for nedfaldende dele pga. løsnede skruer! Personskade pga. nedfaldende dele.</p> <ul style="list-style-type: none"> ▶ Sørg for at sikre komponenten mod at falde ned.

	BEMÆRK!
	<p>Fare for nedfaldende dele pga. løsnede skruer! Beskadigelse af andre apparatdele eller kundens hjem, f.eks. gulvet.</p> <ul style="list-style-type: none"> ▶ Sørg for at sikre komponenten mod at falde ned.

Preindstilling:

- ✅ Apparatet er afbrudt fra strømforsyningen.
- ✅ Indvendigt tilbehør i apparatet er fjernet.
- ✅ Det øverste dørhængsel er fjernet.
- ✅ Den øverste dør er fjernet.

4.5.1 Fjernelse af midterste dørhængsel

1. 1. Skru de to skruer ud (1).
2. Fjern det midterste hængsel (2).

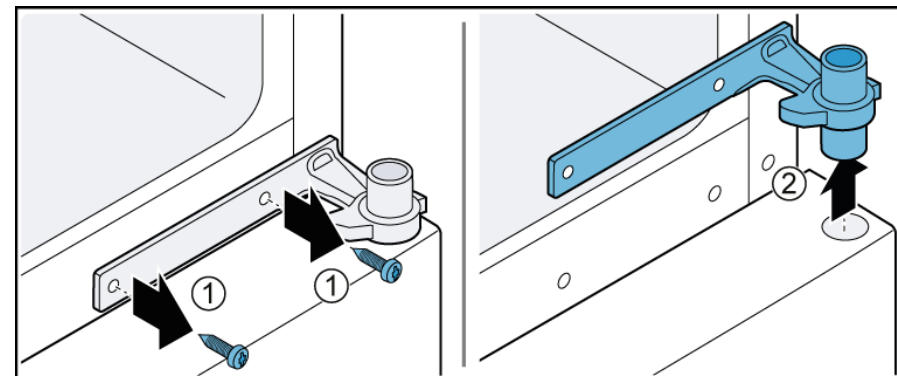

2. Fjern den nederste dør.

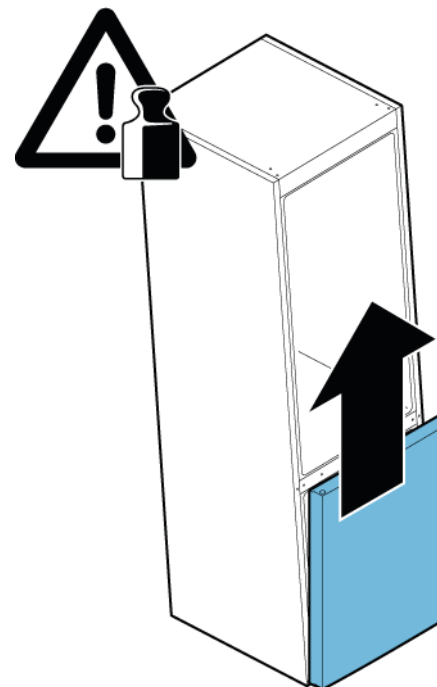

- ➡ Det midterste hængsel er fjernet.

4.5.2 Montering af midterste dørhængsel

- ▶ Montér i omvendt rækkefølge.

4.6 Udskiftning af nederste dørhængsel

Nødvendig værktøj:

🌀 Torx-bit TX20

6,3 mm (1/4")

[00340865]

	⚠ ADVARSEL
	<p>Tunge, store apparater! Ryg- og muskelskader</p> <ul style="list-style-type: none"> ▶ Arbejde til fjernelse af apparatets dør bør kun udføres af uddannede specialister. ▶ Der skal være to personer om at flytte apparatet. ▶ Brug kun egnet værktøj og udstyr.

	⚠ PAS PÅ!
	<p>Skarpe kanter! Snitlæsioner</p> <ul style="list-style-type: none"> ▶ Brug beskyttelseshandsker.

	⚠ ADVARSEL
	<p>Apparater på skrå kan glide! Knoglebrud/klemskader</p> <ul style="list-style-type: none"> ▶ Sørg for at sikre apparater mod at glide.

	⚠ PAS PÅ!
	<p>Fare for nedfaldende dele pga. løsnede skruer! Personskade pga. nedfaldende dele.</p> <ul style="list-style-type: none"> ▶ Sørg for at sikre komponenten mod at falde ned.

	BEMÆRK!
	<p>Fare for nedfaldende dele pga. løsnede skruer! Beskadigelse af andre apparatdele eller kundens hjem, f.eks. gulvet.</p> <ul style="list-style-type: none"> ▶ Sørg for at sikre komponenten mod at falde ned.

Preindstilling:

- ✔ Apparatet er afbrudt fra strømforsyningen.
- ✔ Indvendigt tilbehør i apparatet er fjernet.
- ✔ Det øverste hængsel er fjernet.
- ✔ Det midterste hængsel er fjernet.

4.6.1 Fjernelse af nederste dørhængsel

- ▶ 1. Skru de to skruer ud (1).
- ▶ 2. Fjern det nederste hængsel (2).

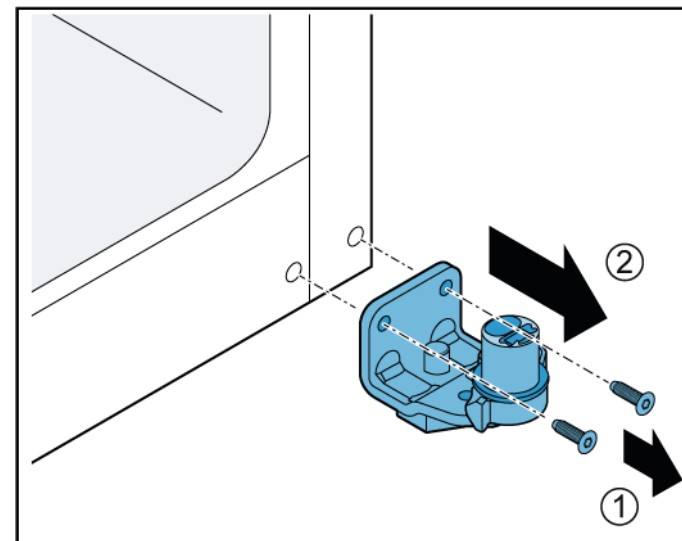

➡ Det nederste dørhængsel er fjernet.

4.6.2 Montering af nederste dørhængsel

- ▶ Montér i omvendt rækkefølge.

4.7 Udskiftning af hylde

Preindstilling:

- ✔ Døren er åben.

4.7.1 Fjernelse af hylde

- ▶ 1. Løft hylde på bagsiden (1).
- ▶ 2. Frigør hylde (2).

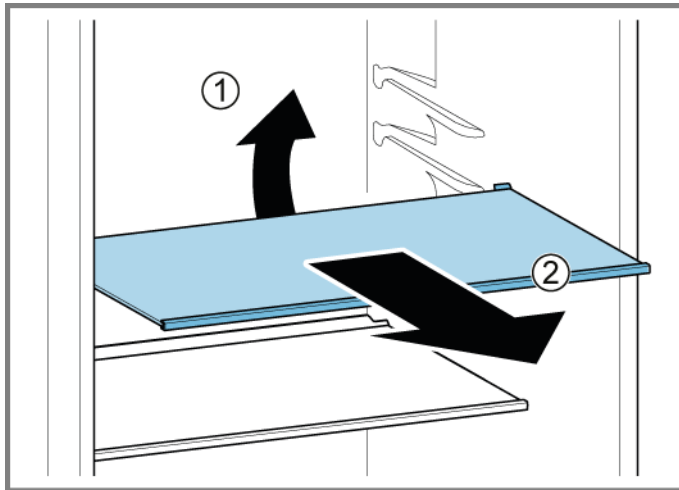

- ➡ Hylde er fjernet.

4.7.2 Montering af hylde

- ▶ Montér i omvendt rækkefølge.

4.8 Udskiftning af flaskehylde

Preindstilling:

- ✔ Døren er åben.

4.8.1 Fjernelse af flaskehylde

- ▶ Træk flaskehylde ud.

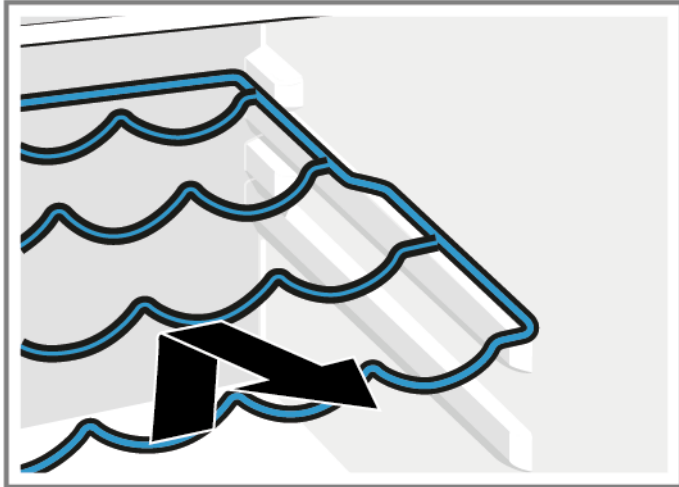

- ➡ Flaskehylde er fjernet.

4.8.2 Montering af flaskehylde

- ▶ Montér i omvendt rækkefølge.

4.9 Udskiftning af dørhylde

Preindstilling:

- ✔ Døren er åben.

4.9.1 Fjernelse af dørhylde

- ▶ Løft dørhylden opad.

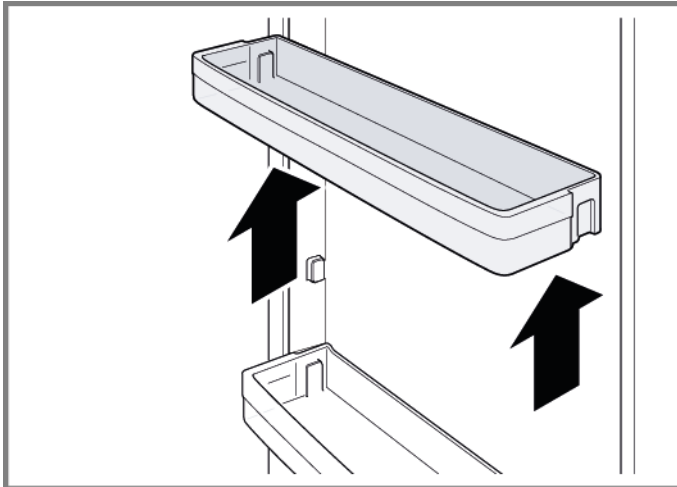

➡ Dørhylden er fjernet.

4.9.2 Montering af dørhylde

- ▶ Montér i omvendt rækkefølge.

4.10 Udskiftning af opbevaringsbeholder

Preindstilling:

- ✔ Døren er åben.

4.10.1 Fjernelse af opbevaringsbeholder

1. Træk opbevaringsbeholderen så langt ud, som den kan komme.
2. 1. Løft opbevaringsbeholderen på forsiden (1).
2. Fjern beholderen (2).

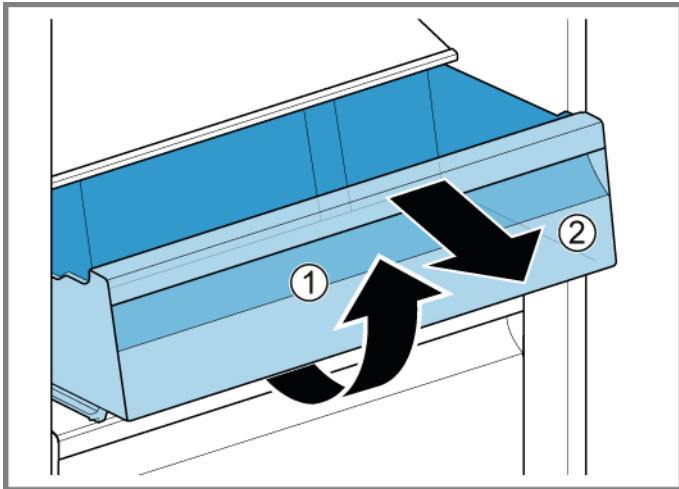

- ➡ Opbevaringsbeholderen er fjernet.

4.10.2 Installation af opbevaringsbeholder

- ▶ Montér i omvendt rækkefølge.

4.11 Udskiftning af frugt- og grøntsagsbeholder

Preindstilling:

- ✔ Døren er åben.

4.11.1 Fjernelse af frugt- og grøntsagsbeholder

1. Træk frugt- og grøntsagsbeholderen så langt ud, som den kan komme.
2. 1. Løft frugt- og grøntsagsbeholderen op foran (1).
2. Fjern beholderen (2).

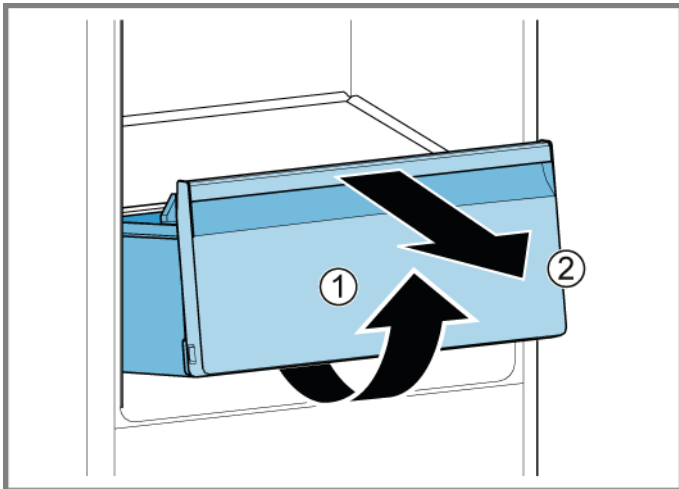

- ➡ Beholderen med frugt og grøntsager er fjernet.

4.11.2 Montering af frugt- og grøntsagsbeholder

- ▶ Montér i omvendt rækkefølge.

4.12 Udskiftning af hylde over frugt- og grøntsagsbeholderen

Preindstilling:

- ✔ Døren er åben.
- ✔ Beholderen med frugt og grøntsager er fjernet. → 112

4.12.1 Fjernelse af hylde over frugt- og grøntsagsbeholderen

1. Skub tætningsrammen opad og ud.

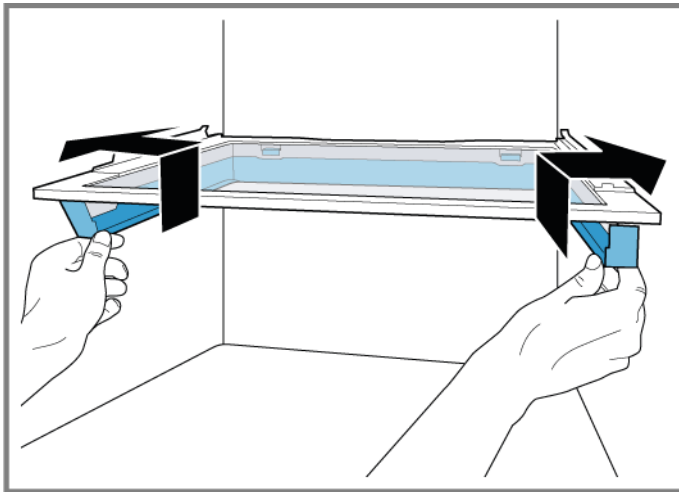

➡ Sidekroge er frigjort.

2. Løft tætningsrammen op, og skub den bagud.

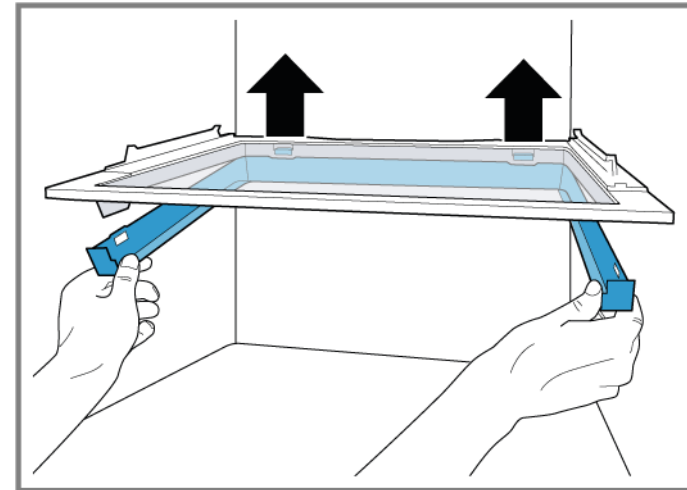

➡ De bageste kroge er frigjort.

3. Fjern tætningsrammen.
4. Løft hylden over frugt- og grøntsagsbeholderen op og drej den ud til siden.

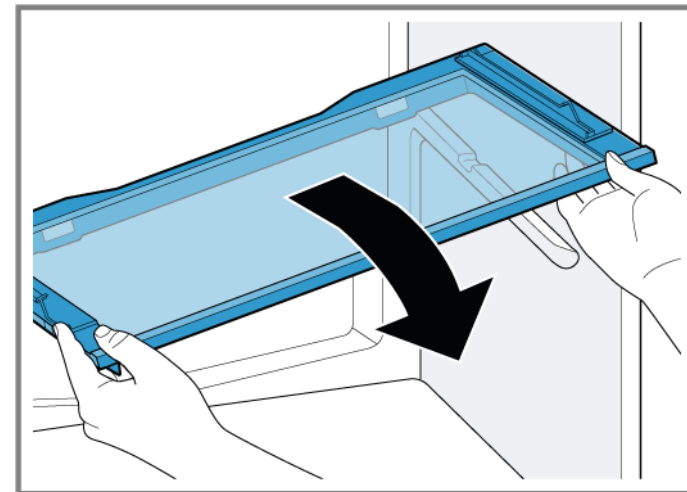

➡ Hylden over frugt- og grøntsagsbeholderen er fjernet.

4.12.2 Montering af hylde over frugt- og grøntsagsbeholderen

- ▶ Montér i omvendt rækkefølge.

4.13 Udskiftning af frostvarebeholder

Preindstilling:

- ✔ Døren er åben.

4.13.1 Fjernelse af frostvarebeholder

- ▶ 1. Træk frostvarebeholderen hele vejen ud (1).
- ▶ 2. Fjern frostvarebeholderen (2).

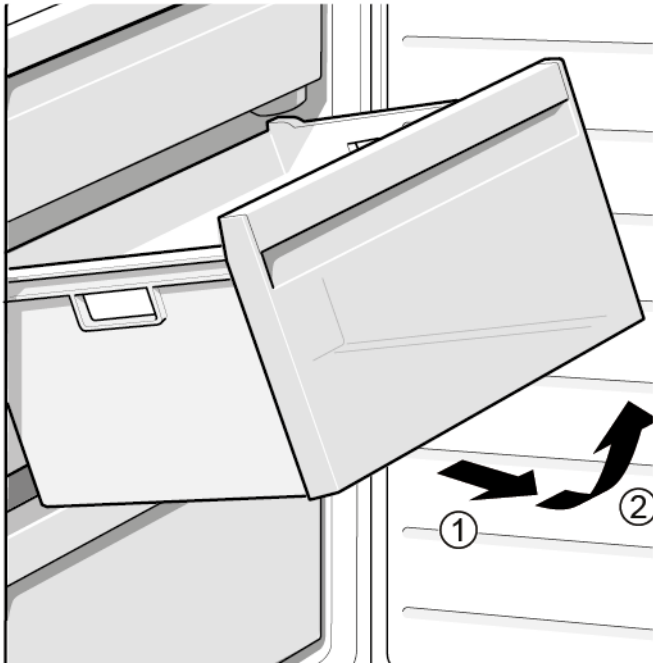

- ➡ Frostvarebeholderen er fjernet.

4.13.2 Montering af frostvarebeholder

- ▶ Montér i omvendt rækkefølge.

4.14 Udskiftning af LED-toplampe

Nødvendig værktøj:

🔧 Specialværktøj

[00342180]

i Dit apparat er udstyret med en vedligeholdelsesfri LED-lampe. Denne lampe må kun repareres af kundeservice eller autoriserede teknikere!

⚠️ FARE
Fare for elektrisk stød pga. spændingsførende dele!
Livsfare pga. elektrisk stød i tilfælde af ukorrekt reparation

- ▶ Elektriske dele skal repareres af kvalificerede elektrikere.
- ▶ Få efter reparationen udført en sikkerhedstest i henhold til VDE 0701 eller landespecifikke forskrifter.

⚠️ FARE
Fare for elektrisk stød pga. spændingsførende dele!
Død ved elektrisk stød

- ▶ Afbryd apparater fra strømforsyningen i mindst 60 sekunder, før reparationer påbegyndes.

⚠️ PAS PÅ!
Skarpe kanter!
Snitlæsioner

- ▶ Brug beskyttelseshandsker.

Preindstilling:

- ✔️ Apparatet er afbrudt fra strømforsyningen.
- ✔️ Døren er åben.

4.14.1 Afmontering af LED-toplampe

1. Skub demonteringsværktøjet mellem LED-toplampen og kølerummets inderbeklædning for at frigøre lampekrogene (1).
2. Fjern den øverste LED-lampe (2).

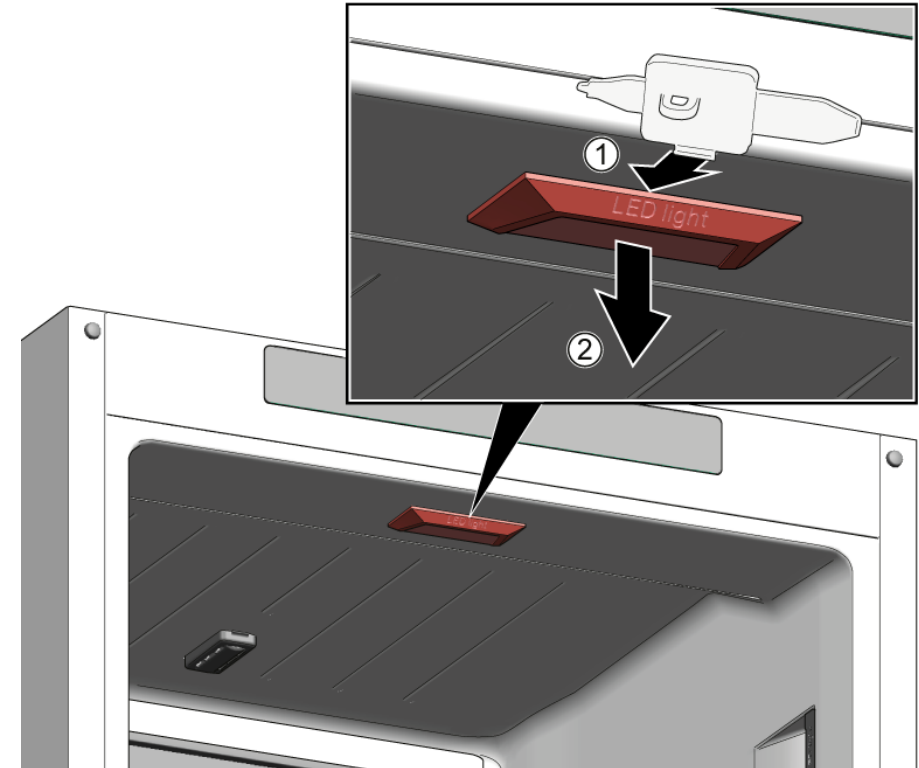

2. Afbryd den elektriske forbindelse til LED-toplampen.
- ➡️ LED-toplampen er fjernet.

4.14.2 Installation af LED-toplampe

- ▶ Montér i omvendt rækkefølge.

4.15 Udskiftning af LED-sidelygte

Nødvendig værktøj:

🔧 Specialværktøj

[00342180]



Dit apparat er udstyret med en vedligeholdelsesfri LED-lampe. Denne lampe må kun repareres af kundeservice eller autoriserede teknikere!



⚠️ FARE

Fare for elektrisk stød pga. spændingsførende dele!

Livsfare pga. elektrisk stød i tilfælde af ukorrekt reparation

- ▶ Elektriske dele skal repareres af kvalificerede elektrikere.
- ▶ Få efter reparationen udført en sikkerhedstest i henhold til VDE 0701 eller landespecifikke forskrifter.



⚠️ FARE

Fare for elektrisk stød pga. spændingsførende dele!

Død ved elektrisk stød

- ▶ Afbryd apparater fra strømforsyningen i mindst 60 sekunder, før reparationer påbegyndes.



⚠️ PAS PÅ!

Skarpe kanter!

Snitlæsioner

- ▶ Brug beskyttelseshandsker.



BEMÆRK!

Fare for beskadigelse af elektrostatisk følsomme komponenter (ESD'er)!

Komponentbeskadigelse

- ▶ Anvend et elektrostatisk beskyttelsessystem (ESD-armbånd), inden ESD'erne berøres.
- ▶ Berør ikke modulernes forbindelser og ledningsbaner.
- ▶ Transportér kun ESD'er i ledende materialer eller original emballage.
- ▶ Hold ESD'er væk fra materialer (f.eks. plastik), der kan oplades elektrostatisk.

Preindstilling:

- ✓ Apparatet er afbrudt fra strømforsyningen.
- ✓ Døren er åben.
- ✓ RC-interiørbeslag er fjernet.

4.15.1 Afmontering af LED-sidelygte

1. Skub demonteringsværktøjet mellem lampediffusoren og huset for at frigøre krogen (1).
2. Tag lampediffusoren (2) ud.
3. Frigør de efterfølgende diffusorfastgørelseskroge på samme måde.

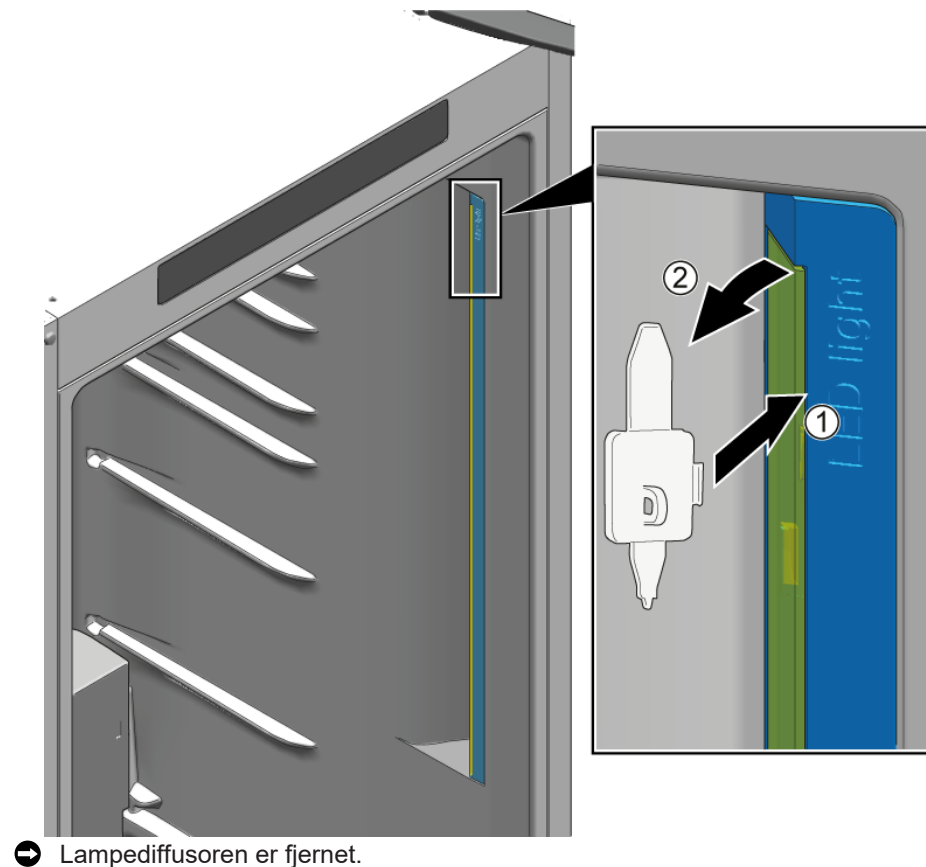

➡ Lampediffusoren er fjernet.

Reparation

1. Tryk på fastgørelseskroge for at frigøre den (1).
2. Flyt LED-modulet ca. 1 cm op for at afbryde det fra stikkontakten (2).
3. Fjern LED-modulet (3).

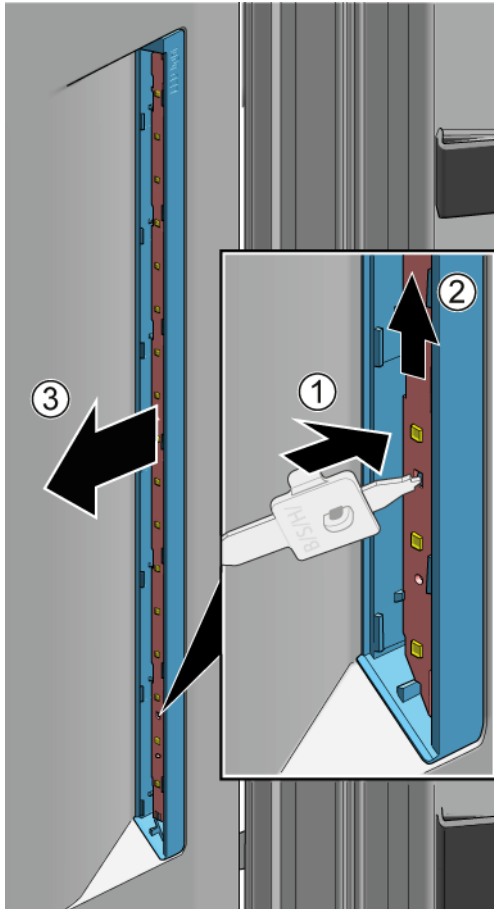

 LED-sidelampen er fjernet.

4.15.2 Montering af LED-sidelygte



Eftersom lampediffusorkroge knækker nemt under fjernelsesprocedu- ren, består LED-sidelampen som reservedel af et sæt, der inkluderer LED-modulet og lampediffusoren.

1. Skub demonteringsværktøjet mellem lampediffusoren og huset for at frigøre krogen (1).
2. Tag lampediffusoren (2) ud.
3. Frigør de efterfølgende diffusorfastgørelseskroge på samme måde.

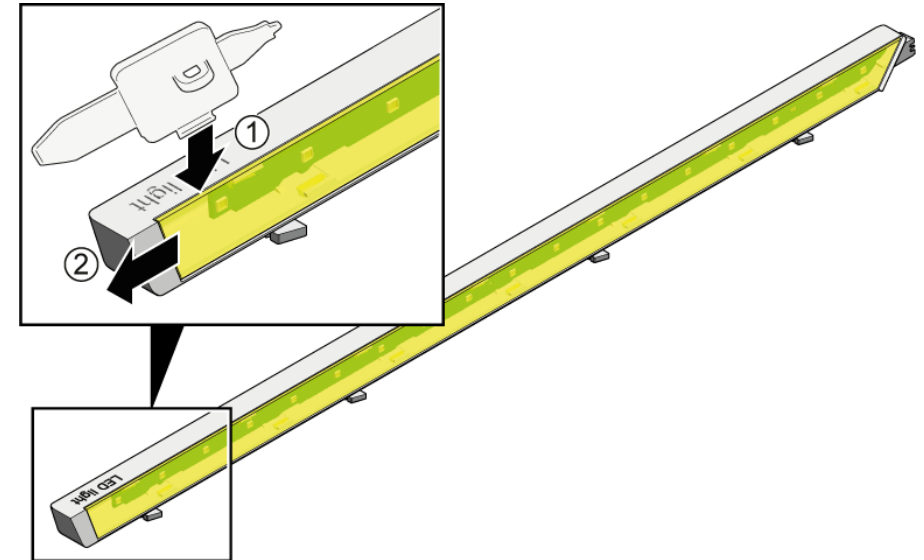

Reparation

2. 1. Tryk på fastgørelseskroge for at frigøre den (1).
2. Skub LED-modulet op og ud af huset.
3. Kassér LED-modulhuset, der anvendes af sikkerhedsmæssige årsager til reservedelstransport (3).

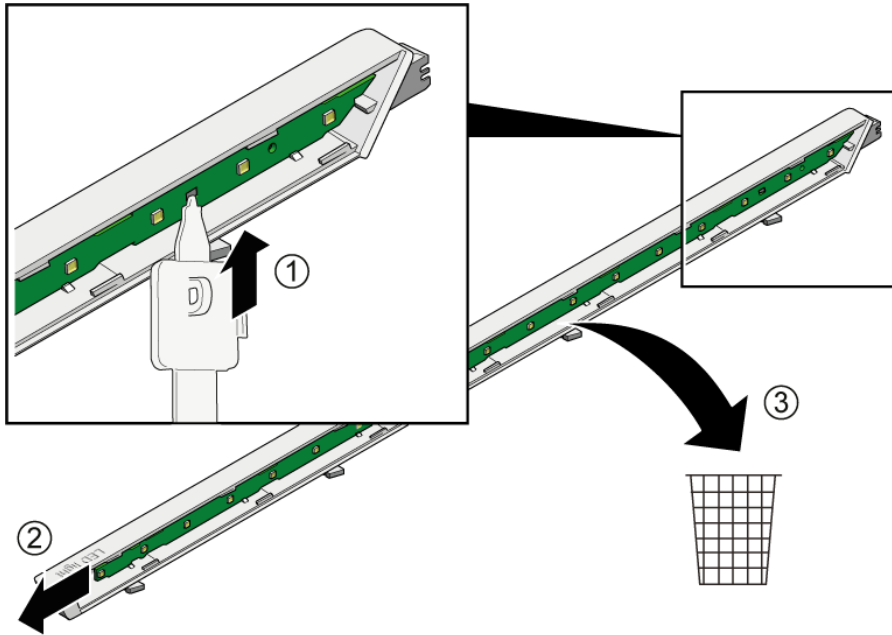

3. Montér LED-modulet og lampediffusoren i omvendt rækkefølge af den, som gælder for fjernelsen.

4.16 Udskiftning af LED-fryselampe

Nødvendig værktøj:

Specialværktøj [00342180]

i Dit apparat er udstyret med en vedligeholdelsesfri LED-lampe. Denne lampe må kun repareres af kundeservice eller autoriserede teknikere!

FARE
Fare for elektrisk stød pga. spændingsførende dele!
Livsfare pga. elektrisk stød i tilfælde af ukorrekt reparation

- ▶ Elektriske dele skal repareres af kvalificerede elektrikere.
- ▶ Få efter reparationen udført en sikkerhedstest i henhold til VDE 0701 eller landespecifikke forskrifter.

FARE
Fare for elektrisk stød pga. spændingsførende dele!
Død ved elektrisk stød

- ▶ Afbryd apparater fra strømforsyningen i mindst 60 sekunder, før reparationer påbegyndes.

PAS PÅ!
Skarpe kanter!
Snitlæsioner

- ▶ Brug beskyttelseshandsker.

Preindstilling:

- ✓ Apparatet er afbrudt fra strømforsyningen.
- ✓ Døren er åben.

4.16.1 Fjernelse af LED-fryselampe

- ▶ 1. Skub demonteringsværktøjet mellem lygten og huset på siden af lygten for at skabe en åbning (1).
- ▶ 2. Skub demonteringsværktøjet på den anden side af lampens fastgørelseskrog, og drej det fremad (2).
- ▶ 3. Fjern LED-fryselampen (3).

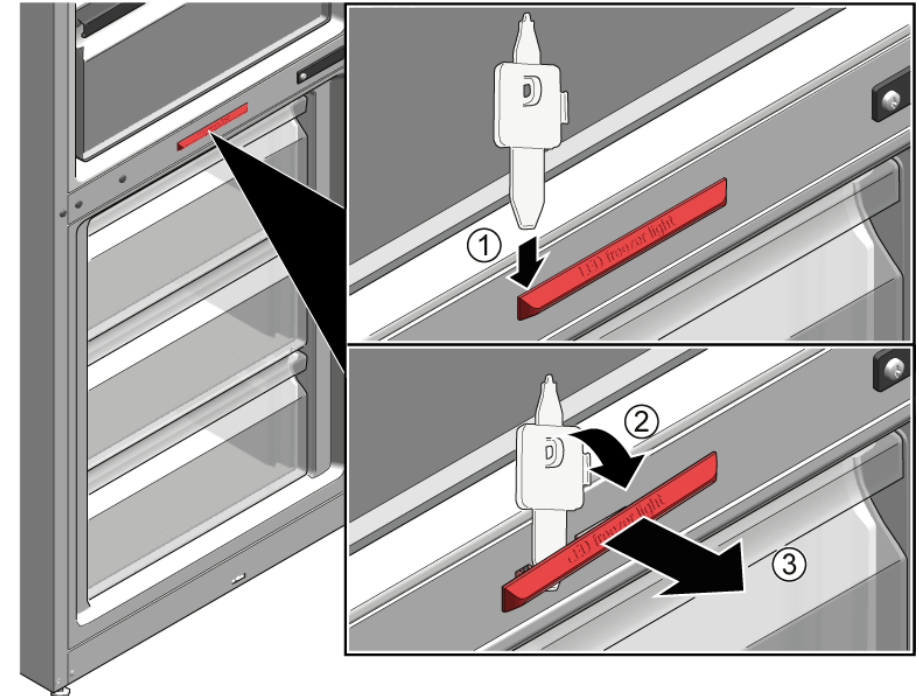





- ➡ LED-fryselampen er frakoblet.
- ➡ LED-fryselampen er fjernet.

4.16.2 LED-fryselampen er fjernet.

- ▶ Montér i omvendt rækkefølge.

Reparatie informatie - Koelvriescombinatie

 Over dit document	122
1.1 Belangrijke informatie	122
1.1.1 Doel	122
1.2 Verklaring van symbolen.....	122
1.2.1 Gevarenniveaus.....	122
1.2.2 Gevarensymbolen.....	122
1.2.3 Structuur van de waarschuwingen.....	123
1.2.4 Algemene symbolen.....	123
 Veiligheid	124
2.1 Algemene veiligheidsinstructies.....	124
2.1.1 Alle huishoudelijke apparaten	124
 Gereedschappen en hulpmiddelen	125
 Reparatie	126
4.1 Deurafdichting vervangen	126
4.1.1 Deurafdichting verwijderen	126
4.1.2 Deurafdichting monteren	126
4.2 Deurgreep vervangen	129
4.2.1 Deurgreep verwijderen	129
4.2.2 Deurgreep monteren	129
4.3 Bovenste deurscharnier vervangen.....	130
4.3.1 Bovenste deurscharnier verwijderen.....	130
4.3.2 Bovenste deurscharnier monteren.....	131
4.4 Bovenste deurscharnier vervangen (deur met display).....	132
4.4.1 Bovenste deurscharnier verwijderen.....	133
4.4.2 Bovenste deurscharnier monteren.....	134
4.5 Middelste deurscharnier vervangen	135
4.5.1 Middelste deurscharnier verwijderen	135
4.5.2 Middelste deurscharnier monteren	136
4.6 Onderste deurscharnier vervangen.....	137
4.6.1 Onderste deurscharnier verwijderen.....	137
4.6.2 Onderste deurscharnier monteren.....	137
4.7 Plateau vervangen.....	138
4.7.1 Plateau verwijderen.....	138
4.7.2 Plateau monteren.....	138
4.8 Flessenrek vervangen	139
4.8.1 Flessenrek verwijderen	139
4.8.2 Flessenrek monteren	139
4.9 Deurrek vervangen	140
4.9.1 Deurrek verwijderen.....	140
4.9.2 Deurrek monteren	140
4.10 Opberglade vervangen	141
4.10.1 Opberglade verwijderen	141
4.10.2 Opberglade installeren	141
4.11 Groente- en fruitlade vervangen.....	142
4.11.1 Groente- en fruitlade verwijderen.....	142
4.11.2 Groente- en fruitlade installeren.....	142
4.12 Legplateau boven groente- en fruitlade vervangen.....	143
4.12.1 Legplateau boven groente- en fruitlade verwijderen.....	143
4.12.2 Het plateau boven de groente- en fruitlade installeren.....	144
4.13 Vrieslade vervangen	145
4.13.1 Vrieslade verwijderen	145
4.13.2 Vrieslade installeren	145
4.14 Bovenste LED-lamp vervangen.....	146
4.14.1 Bovenste LED-lamp verwijderen.....	146
4.14.2 Bovenste LED-lamp monteren.....	146
4.15 LED-zijlamp vervangen	147
4.15.1 LED-zijlamp verwijderen	148
4.15.2 LED-zijlamp monteren	148
4.16 LED-vriesvaklamp vervangen	150
4.16.1 LED-vriesvaklamp verwijderen	150
4.16.2 LED-vriesvaklamp monteren	150

i Over dit document

1.1 Belangrijke informatie

1.1.1 Doel

Met deze reparatieaanwijzingen wordt de klant geholpen zelf apparaten te repareren conform de toepasselijke verordening inzake ecologisch ontwerp (met ingang van 03/2021).

Ze bevatten informatie over hoe gedefinieerde reserveonderdelen kunnen worden vervangen met inbegrip van waarschuwingen en gevaren.

Neem bij vragen contact op met onze klantenservice. We stellen ons alleen aansprakelijk voor schade als de reparatieaanwijzingen correct zijn opgevolgd.

1.2 Verklaring van symbolen

1.2.1 Gevarenniveaus

De waarschuwningsniveaus worden aangegeven met een symbool en een signaalwoord. Het signaalwoord geeft de ernst van het gevaar aan.





Waarschuwningsniveau	Betekenis
 GEVAAR	Als de waarschuwing niet in acht wordt genomen, leidt dat tot ernstig of dodelijk letsel.
 WAARSCHUWING	Als de waarschuwing niet in acht wordt genomen, kan dat tot ernstig of dodelijk letsel leiden.
 VOORZICHTIG	Als de waarschuwing niet in acht wordt genomen, kan dat tot licht letsel leiden.
LET OPI	Als de waarschuwing niet in acht wordt genomen, kan dat tot materiële schade leiden.

Tabel 1: Gevarenniveaus

1.2.2 Gevarensymbolen

Gevarensymbolen zijn symbolische afbeeldingen die een indicatie geven van het soort gevaar.

De volgende gevarensymbolen worden in dit document gebruikt:

Gevarensymbool	Betekenis
	Algemene waarschuwing
	Gevaar voor elektrische spanning
	Ontploffingsgevaar
	Snijgevaar

i Over dit document

Gevarensymbool	Betekenis
	Beknellingsgevaar
	Gevaar voor hete oppervlakken
	Gevaar voor sterke magnetische velden
	Gevaar voor niet-ioniserende straling

Tabel 2: Gevarensymbolen

1.2.3 Structuur van de waarschuwingen

Waarschuwingen in dit document hebben een gestandaardiseerd uiterlijk en een gestandaardiseerde structuur.







	⚠ GEVAAR Soort gevaar en bron van het gevaar! Mogelijke gevolgen van het negeren van het gevaar / de waarschuwing. ▶ Maatregelen en verboden om het gevaar te voorkomen.
--	---

In het volgende voorbeeld is een waarschuwing te zien waarmee voor een elektrische schok aan stroomvoerende onderdelen wordt gewaarschuwd. De maatregel om het gevaar te vermijden wordt vermeld.

	⚠ GEVAAR Gevaar voor een elektrische schok aan stroomvoerende onderdelen! Dood door elektrocutie ▶ Haal apparaten minstens 60 seconden voor u met reparaties begint van de stroomvoorziening af.
--	---

1.2.4 Algemene symbolen

De volgende algemene symbolen worden in dit document gebruikt:

Alg. symbool	Betekenis
	Identificatie van een speciale tip (tekst en/of afbeelding)
	Identificatie van een eenvoudige tip (tekst)
	Identificatie van een link naar een video-instructie
	Identificatie van vereiste gereedschappen
	Identificatie van vereiste voorwaarden
	Identificatie van een voorwaarde (als ..., dan ...)
	Identificatie van een resultaat
[Start]	Identificatie van een toets of knop
[00123456]	Identificatie van een materiaalnummer
Status	Identificatie van weergegeven tekst / venster (in het display van het apparaat)

Tabel 3: Algemene symbolen

2.1 Algemene veiligheidsinstructies

2.1.1 Alle huishoudelijke apparaten

Gevaar voor een elektrische schok aan stroomvoerende onderdelen!

- Fouten bij reparaties aan elektrische componenten kunnen tot een elektrische schok leiden!
- Koppel het apparaat minstens 60 seconden los van het stroomnet voordat u met de werkzaamheden begint.
- Laat na de reparatie een veiligheidstest conform VDE 0701 of de landspecifieke regelgeving uitvoeren.

Gevaar voor letsel aan scherpe randen!

- Draag veiligheidshandschoenen.

Beknellingsgevaar tijdens reparatie, onderhoud, probleemoplossing en service vanwege zware en bewegende componenten

- Draag veiligheidsschoenen.
- Beveilig zware componenten tegen vallen.
- Steek geen lichaamsdelen in bewegende componenten.

Gevaar voor de veiligheid / werking van het apparaat!

- Gebruik uitsluitend originele reserveonderdelen.

Gevaar voor schade aan elektrostatisch gevoelige componenten (ESD's)!

- Raak de modules met inbegrip van de aansluitingen en geleiderbanen niet aan.

Gereedschappen en hulpmiddelen

Benaming	Details	Afbeeldingen
Torxbit TX20 [00340865]	6,3 mm (1/4")	
Speciaal gereedschap [00342180]		

4.1 Deurafdichting vervangen

Voorwaarde:

- ✔ Deur is open.

4.1.1 Deurafdichting verwijderen

1. Haal deurafdichting los uit de sleuf in de rechter- en linkerhoek.

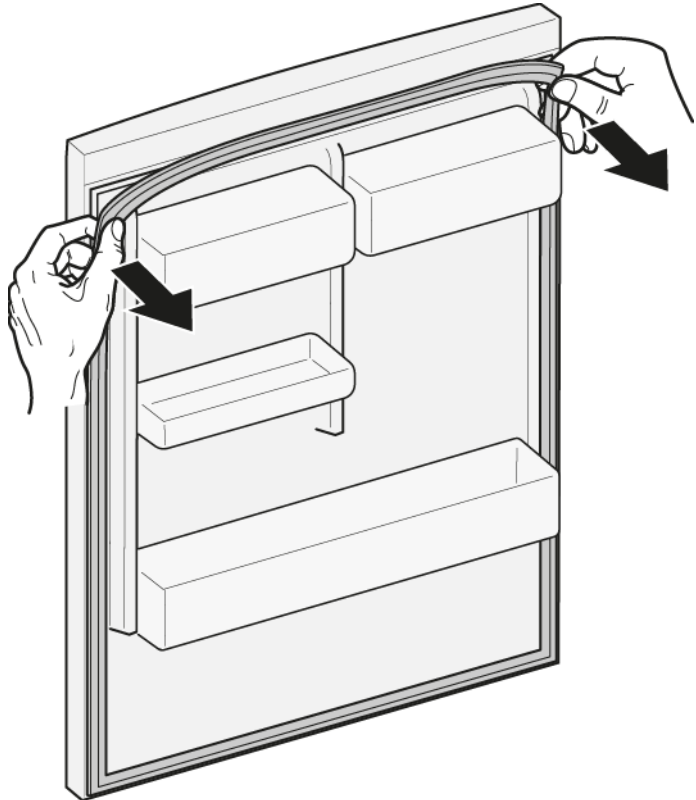

2. Trek deurafdichting uit gleuf.

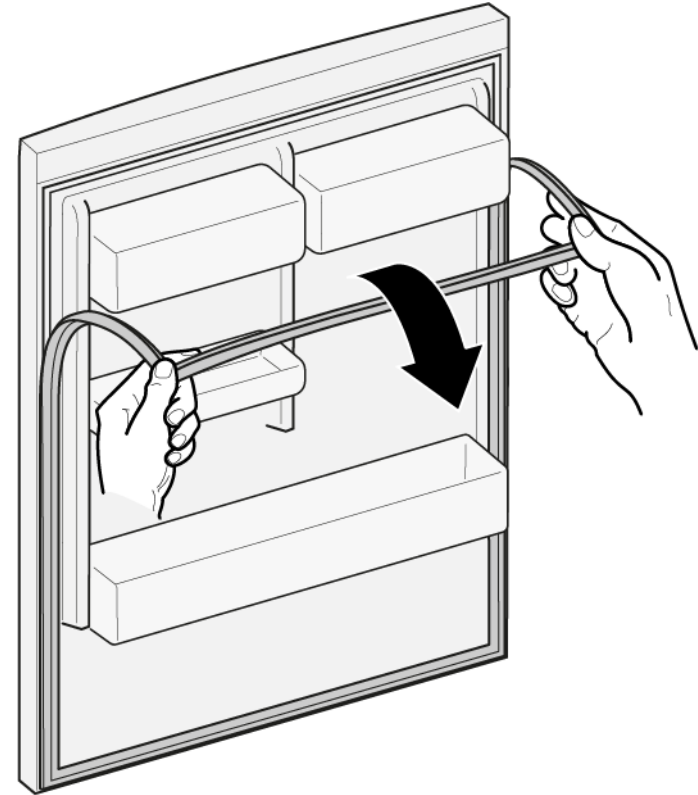

- ➡ Deurafdichting wordt verwijderd.

4.1.2 Deurafdichting monteren



De dikte van de nieuwe deurafdichting kan licht afwijken van de dikte van de oude deurafdichting. Dit doet geen afbreuk aan de sluiteigenschappen en de werking op de lange termijn.

Als uw apparaat verstelbare scharnieren of scharnierbevestigingen heeft, kunt u de sluiteigenschappen later optimaliseren.

De zijgaatjes in de deurafdichting zijn functioneel (vereist voor ventilatie). Dit zijn geen productiefouten.

Reparatie

1. Controleer de sleuf voor de afdichting op schade.

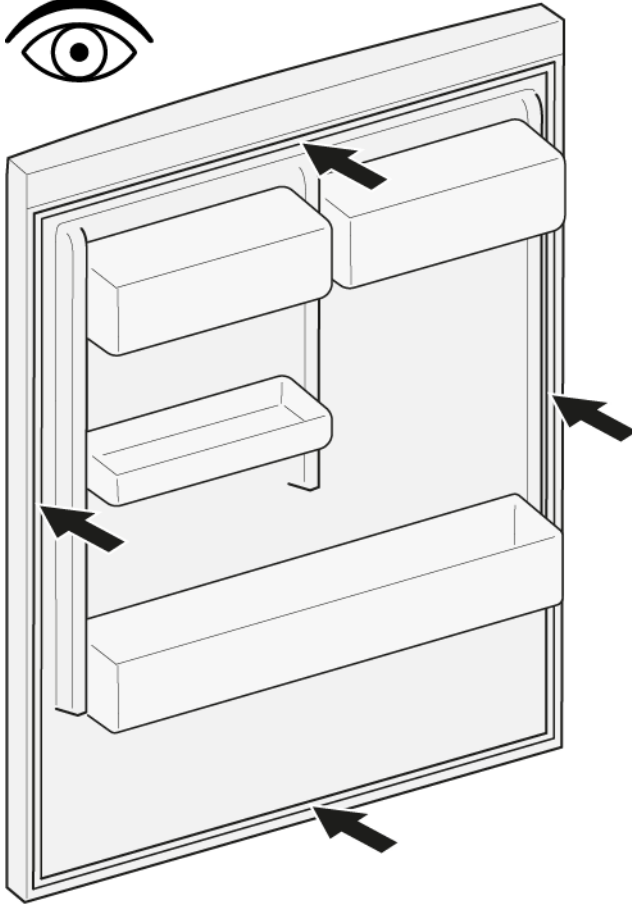

4. Duw de hoeken van de afdichting bovenaan en onderaan in de sleuf.

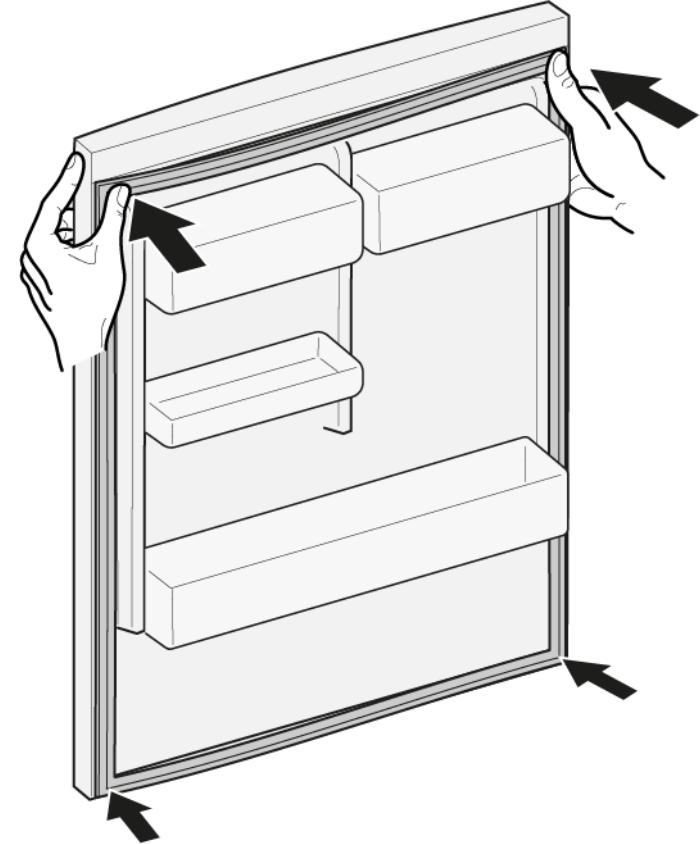

2.  Als de sleuf voor de afdichting is beschadigd:
 - Neem contact op met de klantenservice.

3.  Een lichte vervorming van de deurafdichting is normaal en doet geen afbreuk aan de werking. Geadviseerd wordt de deurafdichting recht te trekken voordat u deze in het apparaat steekt.

Verwarm de deurafdichting met een haardroger of met warm water en breng het handmatig terug in zijn vorm.

Reparatie

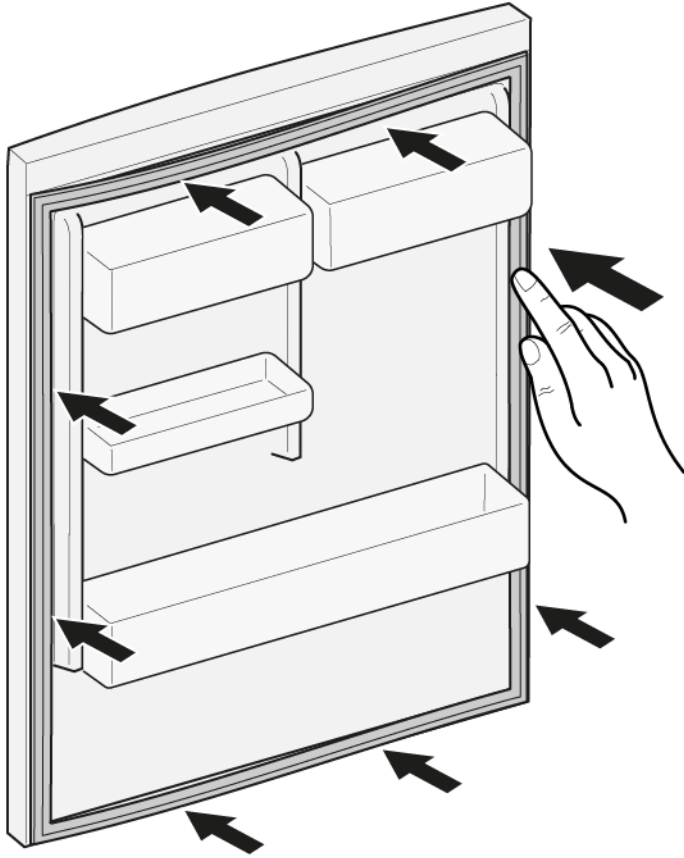

5. Druk de hele afdichting stap voor stap in de sleuf.





 De deurafdichting wordt gemonteerd.

4.2 Deurgreep vervangen

Speciale hulpmiddelen:

-  Torxbit TX20 6,3 mm (1/4") [00340865]
-  Sleufschroevendraaier Kop 10 mm x 1,6 mm x 200 mm

Voorwaarde:

-  Apparaat is losgekoppeld is van de stroomvoorziening.
-  Deur is open.

4.2.1 Deurgreep verwijderen

- ▶ 1. Verwijder twee schroefkappen (1).
- ▶ 2. Draai de twee schroeven los (2).
- ▶ 3. Verwijder de deurgreep (3).

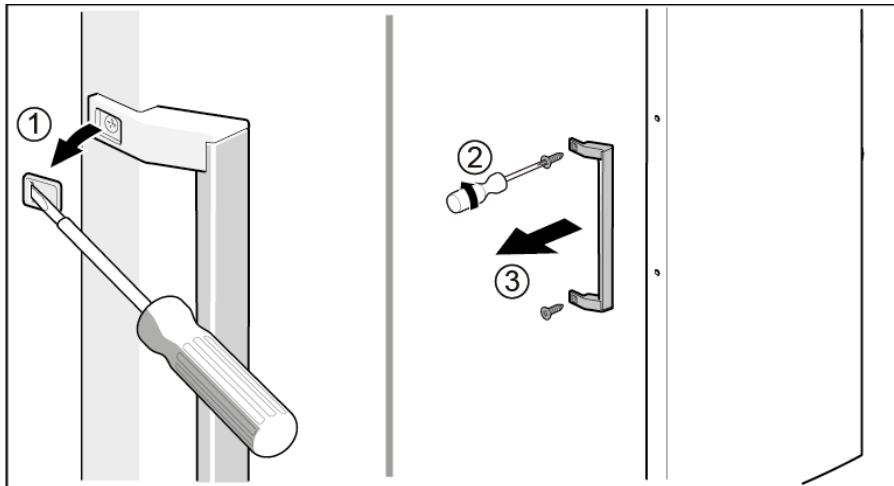

 Deurgreep wordt verwijderd.



Deurgreep voor de tweede deur kan op dezelfde manier worden verwijderd.

4.2.2 Deurgreep monteren

- ▶ Monteer in omgekeerde volgorde.





4.3 Bovenste deurscharnier vervangen

Speciale hulpmiddelen:

Torxbit TX20

6,3 mm (1/4")

[00340865]

	<p>WAARSCHUWING</p> <p>Zware, omvangrijke apparaten! Rug- en spierletsel</p> <ul style="list-style-type: none"> ▶ De werkzaamheid van het verwijderen van de apparaatdeur mag alleen worden uitgevoerd door speciaal opgeleid personeel. ▶ Om het apparaat te verplaatsen zijn twee mensen nodig. ▶ Gebruik alleen geschikte gereedschappen en apparatuur.
	<p>VOORZICHTIG</p> <p>Scherpe randen! Snijletsel</p> <ul style="list-style-type: none"> ▶ Draag veiligheidshandschoenen.
	<p>WAARSCHUWING</p> <p>Weggliden van schuin staande apparaten! Botbreuken / beknellingsletsel</p> <ul style="list-style-type: none"> ▶ Beveilig apparaten tegen wegglijden.
	<p>VOORZICHTIG</p> <p>Gevaar voor vallende onderdelen als gevolg van losgeraakte schroeven! Letsel als gevolg van vallende onderdelen.</p> <ul style="list-style-type: none"> ▶ Beveilig component tegen vallen.
	<p>LET OP!</p> <p>Gevaar voor vallende onderdelen als gevolg van losgeraakte schroeven! Schade aan andere onderdelen van het apparaat of bij de klant thuis bijvoorbeeld aan de vloer.</p> <ul style="list-style-type: none"> ▶ Beveilig component tegen vallen.

Voorwaarde:

- ✓ Apparaat is losgekoppeld van de stroomvoorziening.
- ✓ Het interieur van het apparaat is verwijderd.

4.3.1 Bovenste deurscharnier verwijderen

1. Schuif het ondersteuningsstuk onder de onderste sectie.

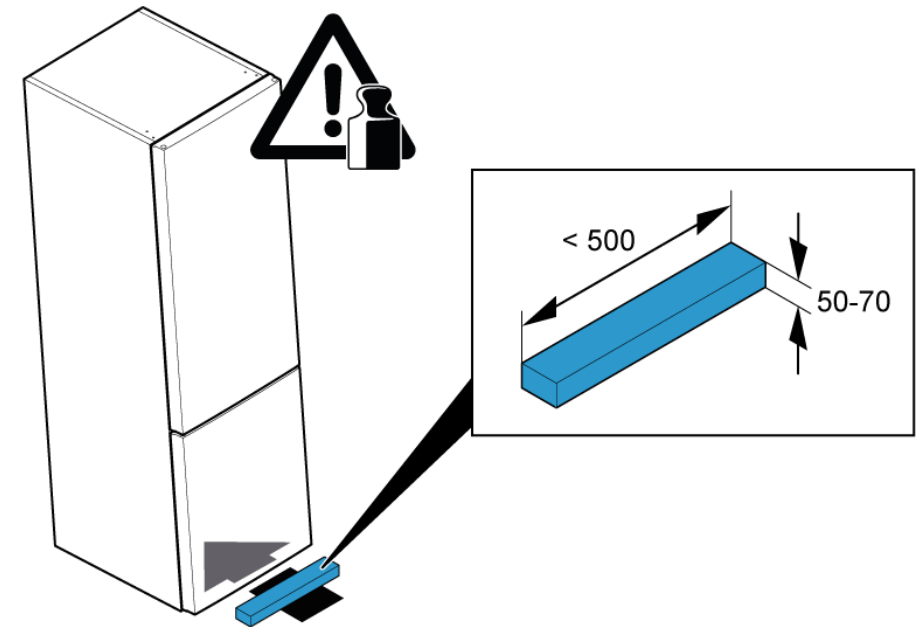

2. 1. Verwijder de bovenste scharnierafdekking (1).
2. Draai de twee schroeven los (2).
3. Verwijder het bovenste scharnier (3).

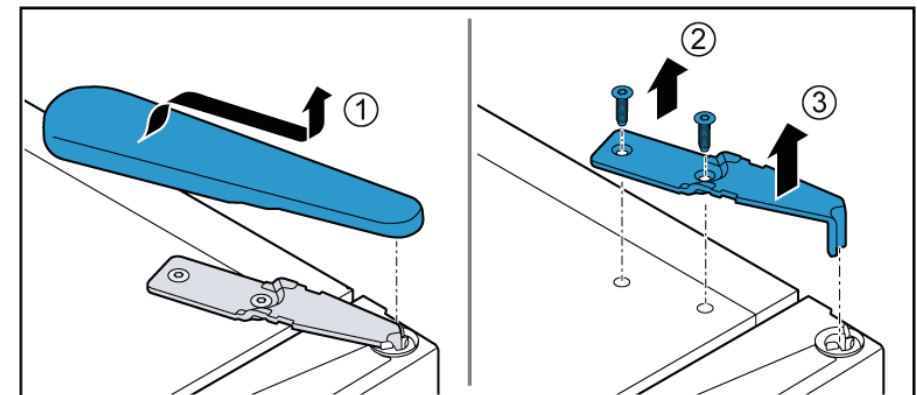

3. Verwijder de bovendeur.

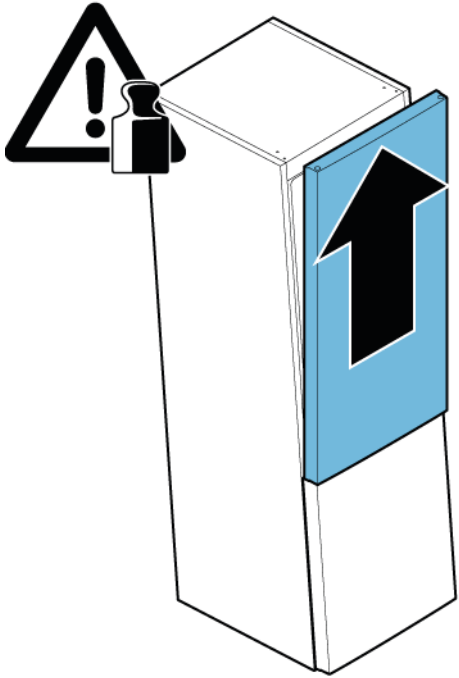

 Het bovenste scharnier wordt verwijderd.

4.3.2 Bovenste deurscharnier monteren

► Monteer in omgekeerde volgorde.

4.4 Bovenste deurscharnier vervangen (deur met display)

Speciale hulpmiddelen:

 Torxbit TX20 6,3 mm (1/4") [00340865]

	⚠ WAARSCHUWING
	Zware, omvangrijke apparaten! Rug- en spierletsel <ul style="list-style-type: none">▶ De werkzaamheid van het verwijderen van de apparaatdeur mag alleen worden uitgevoerd door speciaal opgeleid personeel.▶ Om het apparaat te verplaatsen zijn twee mensen nodig.▶ Gebruik alleen geschikte gereedschappen en apparatuur.

	⚠ VOORZICHTIG
	Scherpe randen! Snijletsel <ul style="list-style-type: none">▶ Draag veiligheidshandschoenen.

	⚠ WAARSCHUWING
	Weggliden van schuin staande apparaten! Botbreuken / beknellingsletsel <ul style="list-style-type: none">▶ Beveilig apparaten tegen wegglijden.



	⚠ VOORZICHTIG
	Gevaar voor vallende onderdelen als gevolg van losgeraakte schroeven! Letsel als gevolg van vallende onderdelen. <ul style="list-style-type: none">▶ Beveilig component tegen vallen.

	LET OP!
	Gevaar voor vallende onderdelen als gevolg van losgeraakte schroeven! Schade aan andere onderdelen van het apparaat of bij de klant thuis bijvoorbeeld aan de vloer. <ul style="list-style-type: none">▶ Beveilig component tegen vallen.

	⚠ GEVAAR
	Gevaar voor een elektrische schok aan stroomvoerende onderdelen! Levensgevaar door elektrische schokken in geval van een ondeskundige reparatie <ul style="list-style-type: none">▶ Elektrische onderdelen moeten door gekwalificeerde elektriciens worden gerepareerd.▶ Laat na de reparatie een veiligheidstest conform VDE 0701 of de landspecifieke regelgeving uitvoeren.

	⚠ GEVAAR
	Gevaar voor een elektrische schok aan stroomvoerende onderdelen! Dood door elektrocutie <ul style="list-style-type: none">▶ Haal apparaten minstens 60 seconden voor u met reparaties begint van de stroomvoorziening af.

Voorwaarde:

-  Apparaat is losgekoppeld is van de stroomvoorziening.
-  Het interieur van het apparaat is verwijderd.

4.4.1 Bovenste deurscharnier verwijderen

1. Schuif het ondersteuningsstuk onder de onderste sectie.

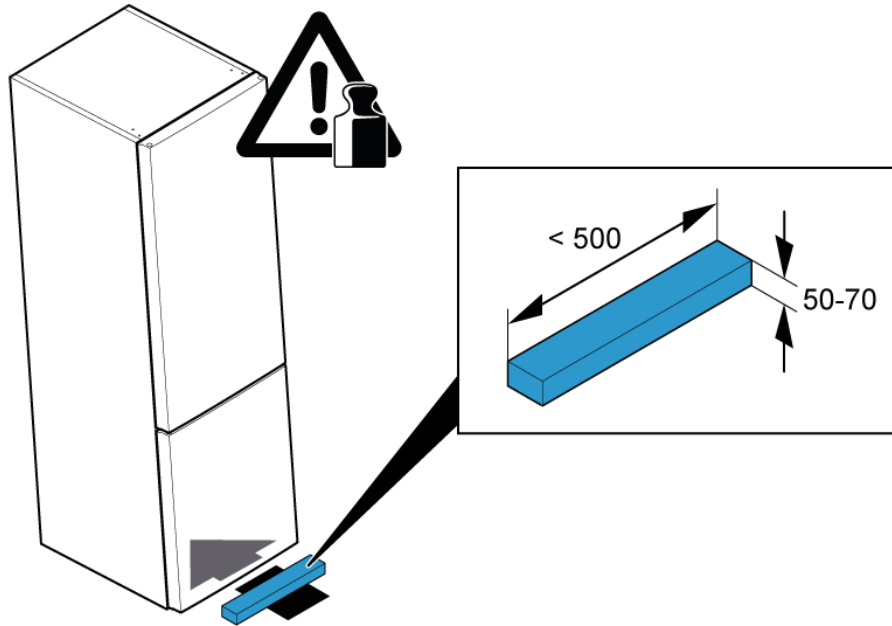

2. 1. Verwijder de bovenste scharnierafdekking (1).
2. Haal de elektrische aansluiting los (2).
3. Draai de aardverbindingsschroef los (3).

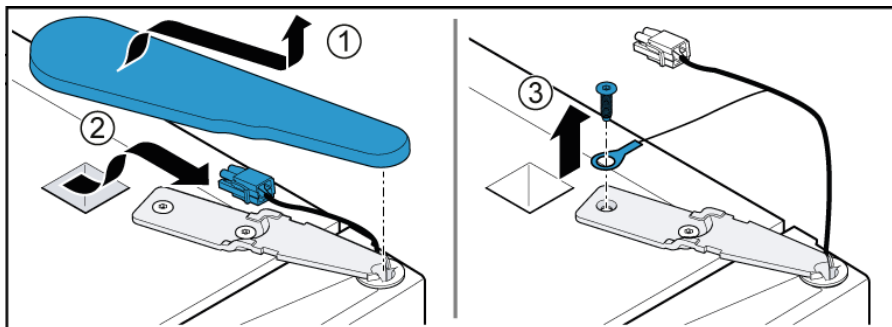

3. 1. Draai de schroef (1) los.
2. Verwijder het bovenste scharnier (2).

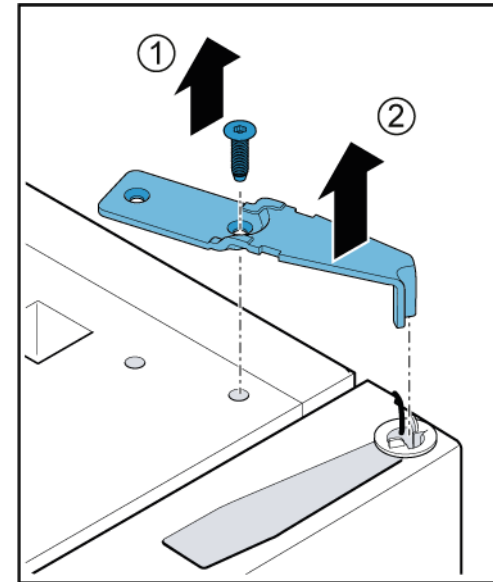

4. Verwijder de bovendeur.

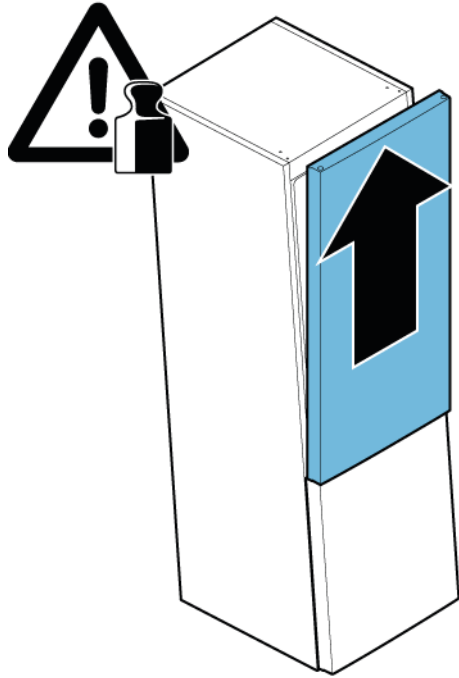

 Het bovenste scharnier wordt verwijderd.

4.4.2 Bovenste deurscharnier monteren

▶ Monteer in omgekeerde volgorde.

4.5 Middelste deurscharnier vervangen

Speciale hulpmiddelen:

 Torxbit TX20

6,3 mm (1/4")

[00340865]

	<p>WAARSCHUWING</p> <p>Zware, omvangrijke apparaten! Rug- en spierletsel</p> <ul style="list-style-type: none">▶ De werkzaamheid van het verwijderen van de apparaatdeur mag alleen worden uitgevoerd door speciaal opgeleid personeel.▶ Om het apparaat te verplaatsen zijn twee mensen nodig.▶ Gebruik alleen geschikte gereedschappen en apparatuur.
--	---



	<p>VOORZICHTIG</p> <p>Scherpe randen! Snijletsel</p> <ul style="list-style-type: none">▶ Draag veiligheidshandschoenen.
--	---



	<p>WAARSCHUWING</p> <p>Weggliden van schuin staande apparaten! Botbreuken / beknellingsletsel</p> <ul style="list-style-type: none">▶ Beveilig apparaten tegen wegglijden.
--	--

	<p>VOORZICHTIG</p> <p>Gevaar voor vallende onderdelen als gevolg van losgeraakte schroeven! Letsel als gevolg van vallende onderdelen.</p> <ul style="list-style-type: none">▶ Beveilig component tegen vallen.
---	---

	<p>LET OP!</p> <p>Gevaar voor vallende onderdelen als gevolg van losgeraakte schroeven! Schade aan andere onderdelen van het apparaat of bij de klant thuis bijvoorbeeld aan de vloer.</p> <ul style="list-style-type: none">▶ Beveilig component tegen vallen.
--	---

Voorwaarde:

-  Apparaat is losgekoppeld van de stroomvoorziening.
-  De interieurdelen van het apparaat worden verwijderd.

-  Het bovenste deurscharnier wordt verwijderd.
-  Bovendeur wordt verwijderd.

4.5.1 Middelste deurscharnier verwijderen

1. Draai de twee schroeven los (1).
2. Verwijder het middelste scharnier (2).

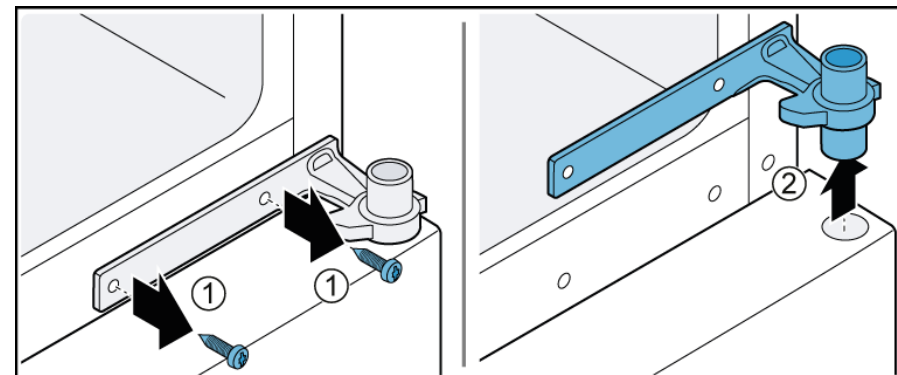

Reparatie

2. Verwijder de onderdeur.

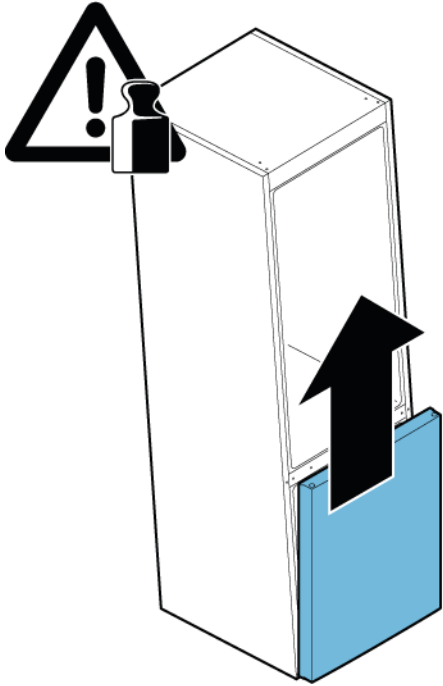

 Het middelste scharnier wordt verwijderd.

4.5.2 Middelste deurscharnier monteren

► Monteer in omgekeerde volgorde.

4.6 Onderste deurscharnier vervangen

Speciale hulpmiddelen:

Torxbit TX20

6,3 mm (1/4")

[00340865]

	<p>WAARSCHUWING</p> <p>Zware, omvangrijke apparaten! Rug- en spierletsel</p> <ul style="list-style-type: none"> ▶ De werkzaamheid van het verwijderen van de apparaatdeur mag alleen worden uitgevoerd door speciaal opgeleid personeel. ▶ Om het apparaat te verplaatsen zijn twee mensen nodig. ▶ Gebruik alleen geschikte gereedschappen en apparatuur.
	<p>VOORZICHTIG</p> <p>Scherpe randen! Snijletsel</p> <ul style="list-style-type: none"> ▶ Draag veiligheidshandschoenen.
	<p>WAARSCHUWING</p> <p>Weggliden van schuin staande apparaten! Botbreuken / beknellingsletsel</p> <ul style="list-style-type: none"> ▶ Beveilig apparaten tegen wegglijden.
	<p>VOORZICHTIG</p> <p>Gevaar voor vallende onderdelen als gevolg van losgeraakte schroeven! Letsel als gevolg van vallende onderdelen.</p> <ul style="list-style-type: none"> ▶ Beveilig component tegen vallen.
	<p>LET OP!</p> <p>Gevaar voor vallende onderdelen als gevolg van losgeraakte schroeven! Schade aan andere onderdelen van het apparaat of bij de klant thuis bijvoorbeeld aan de vloer.</p> <ul style="list-style-type: none"> ▶ Beveilig component tegen vallen.

Voorwaarde:

- ✓ Apparaat is losgekoppeld is van de stroomvoorziening.
- ✓ Het interieur van het apparaat is verwijderd.

- ✓ Het bovenste scharnier wordt verwijderd.
- ✓ Het middelste scharnier wordt verwijderd.

4.6.1 Onderste deurscharnier verwijderen

- ▶ 1. Draai de twee schroeven los (1).
- ▶ 2. Verwijder het onderste scharnier (2).

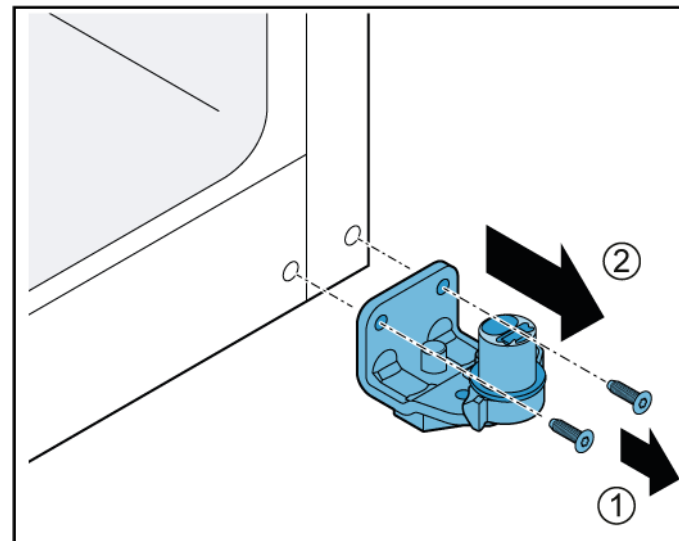

- ➡ Het onderste deurscharnier wordt verwijderd.

4.6.2 Onderste deurscharnier monteren

- ▶ Monteer in omgekeerde volgorde.

4.7 Plateau vervangen

Voorwaarde:

- ✔ Deur is open.

4.7.1 Plateau verwijderen

- ▶ 1. Til het legplateau aan de achterkant op (1).
- ▶ 2. Haal het legplateau los (2).

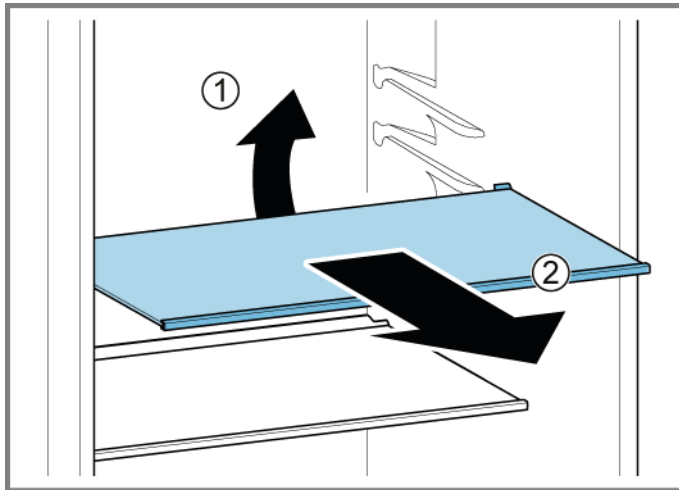

➡ Legplateau wordt verwijderd.

4.7.2 Plateau monteren

- ▶ Monteer in omgekeerde volgorde.

4.8 Flessenrek vervangen

Voorwaarde:

- ✔ Deur is open.

4.8.1 Flessenrek verwijderen

- ▶ Trek het flessenrek eruit.

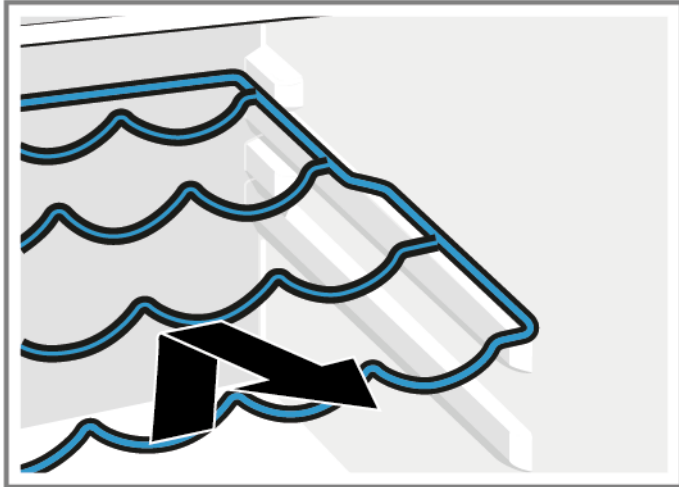

- ➡ Flessenrek wordt verwijderd.

4.8.2 Flessenrek monteren

- ▶ Monteer in omgekeerde volgorde.

4.9 Deurrek vervangen

Voorwaarde:

- ✔ Deur is open.

4.9.1 Deurrek verwijderen

- ▶ Licht het deurrek omhoog.

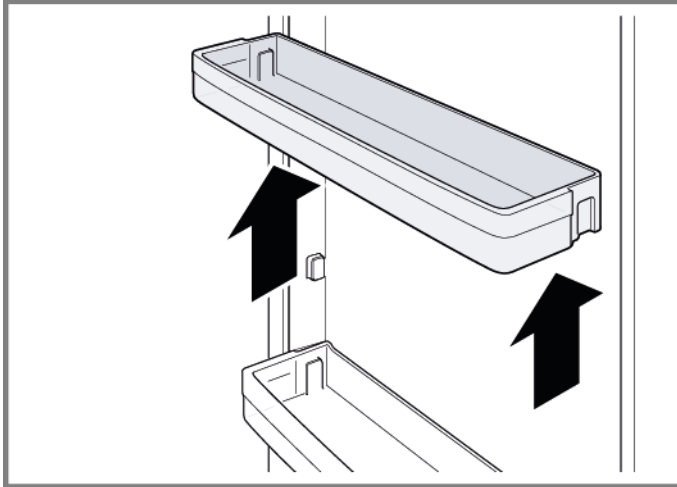

➡ Deurrek wordt verwijderd.

4.9.2 Deurrek monteren

- ▶ Monteer in omgekeerde volgorde.

4.10 Opbergglade vervangen

Voorwaarde:

- ✔ Deur is open.

4.10.1 Opbergglade verwijderen

1. Trek de opberglade zo ver mogelijk naar buiten.
2. 1. Til de opberglade aan de voorkant op (1).
2. Verwijder de lade (2).

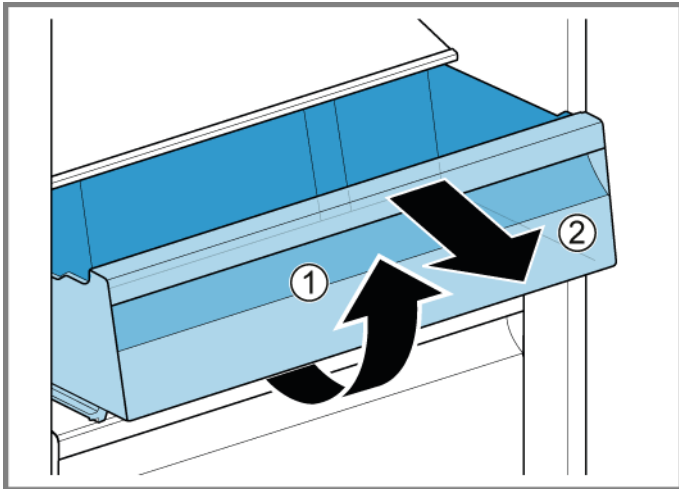

- ⚠ De opberglade wordt verwijderd.

4.10.2 Opberglade installeren

- ▶ Monteer in omgekeerde volgorde.

4.11 Groente- en fruitlade vervangen

Voorwaarde:

- ✔ Deur is open.

4.11.1 Groente- en fruitlade verwijderen

1. Trek de groente- en fruitlade zo ver mogelijk naar buiten.
2. 1. Til de groente- en fruitlade aan de voorkant op (1).
2. Verwijder de lade (2).

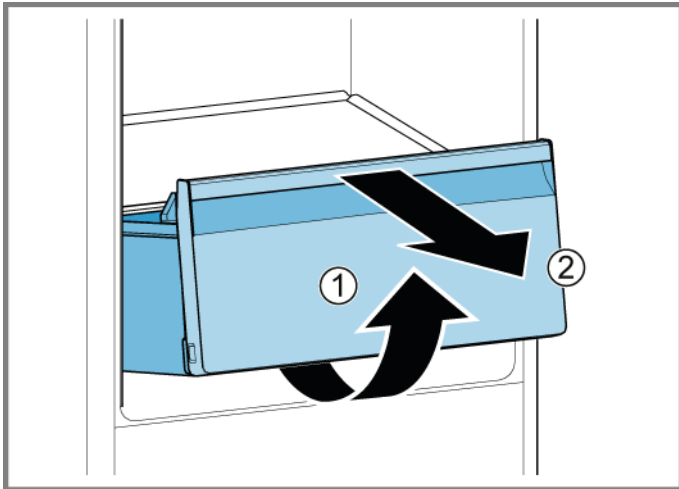

- ➡ De groente- en fruitlade wordt verwijderd.

4.11.2 Groente- en fruitlade installeren

- ▶ Monteer in omgekeerde volgorde.

4.12 Legplateau boven groente- en fruitlade vervangen

Voorwaarde:

- ✓ Deur is open.
- ✓ [De groente- en fruitlade wordt verwijderd. → 142](#)

4.12.1 Legplateau boven groente- en fruitlade verwijderen

1. Duw het afdekframe omhoog en eruit.

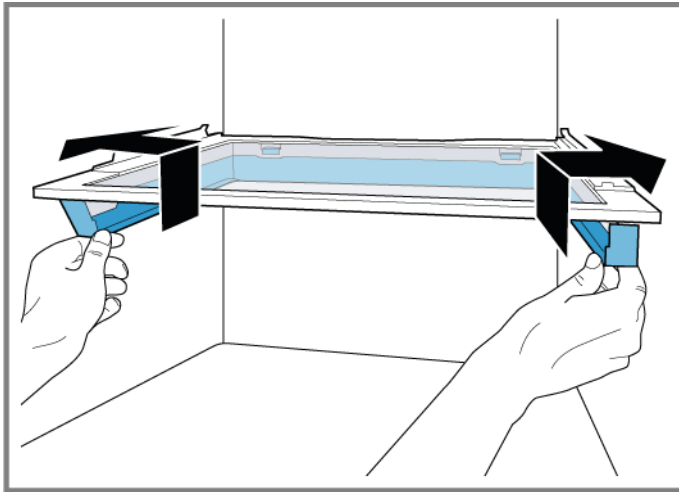

- ➡ Deze zijhaken worden losgehaald.

2. Til het afdekframe omhoog en schuif hem naar achteren.

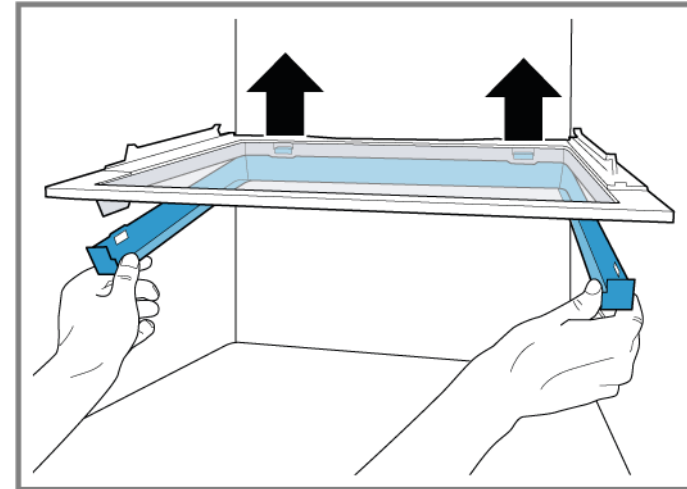

- ➡ Deze achterhaken worden losgehaald.

3. Verwijder het afdekframe.
4. Til het legplateau boven de groente- en fruitlade omhoog en zwenk het er naar de zijkant uit.

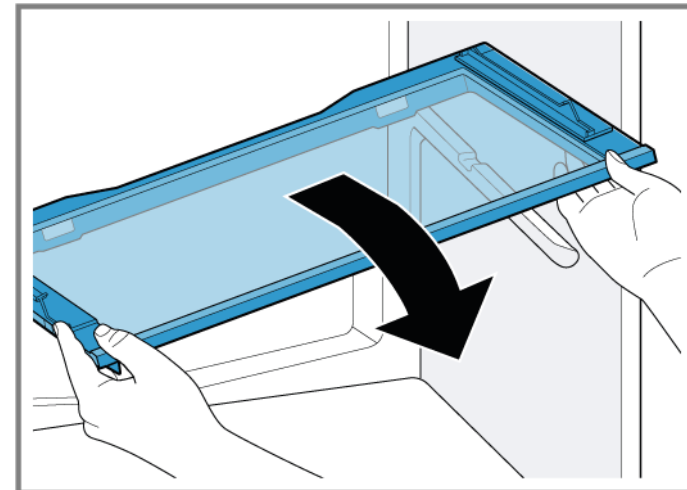

- ➡ Het plateau boven de groente- en fruitlade wordt verwijderd.

4.12.2 Het plateau boven de groente- en fruitlade installeren

- ▶ Monteer in omgekeerde volgorde.

4.13 Vrieslade vervangen

Voorwaarde:

- ✔ Deur is open.

4.13.1 Vrieslade verwijderen

- ▶ 1. Trek de vrieslade er helemaal uit (1).
- ▶ 2. Verwijder de vrieslade (2).

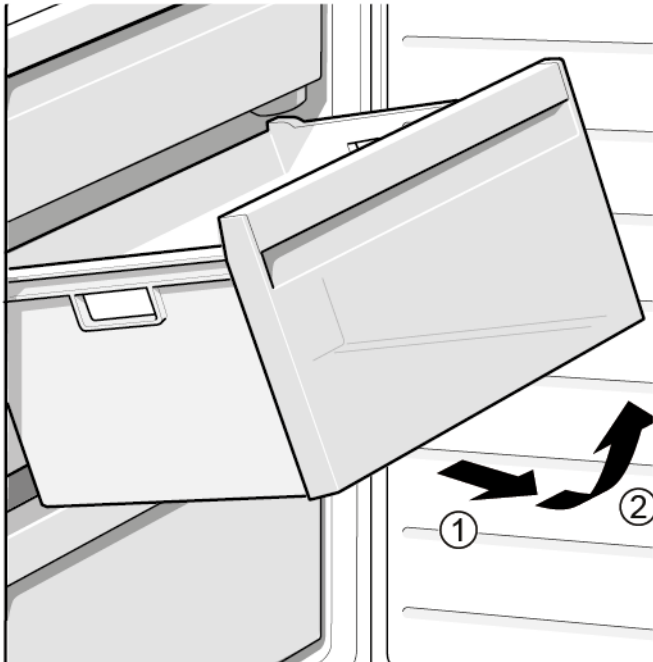

- ➡ Vrieslade wordt verwijderd.

4.13.2 Vrieslade installeren

- ▶ Monteer in omgekeerde volgorde.

4.14 Bovenste LED-lamp vervangen

Speciale hulpmiddelen:

Speciaal gereedschap

[00342180]

i Uw apparaat heeft een onderhoudsvrije LED-lamp. Deze lampen mogen alleen maar door de klantenservice of geautoriseerde monteurs worden vervangen!

⚠ GEVAAR
Gevaar voor een elektrische schok aan stroomvoerende onderdelen!
Levensgevaar door elektrische schokken in geval van een ondeskundige reparatie

- ▶ Elektrische onderdelen moeten door gekwalificeerde elektriciens worden gerepareerd.
- ▶ Laat na de reparatie een veiligheidstest conform VDE 0701 of de landspecifieke regelgeving uitvoeren.

⚠ GEVAAR
Gevaar voor een elektrische schok aan stroomvoerende onderdelen!
Dood door elektrocutie

- ▶ Haal apparaten minstens 60 seconden voor u met reparaties begint van de stroomvoorziening af.

⚠ VOORZICHTIG
Scherpe randen!
Snijletsel

- ▶ Draag veiligheidshandschoenen.

Voorwaarde:

- ✔ Apparaat wordt van de stroomvoorziening afgehaald.
- ✔ Deur is open.

4.14.1 Bovenste LED-lamp verwijderen

1. Schuif het demontagegereedschap tussen de bovenste LED-lamp en de innerliner van het koelvak om de lamphaken los te halen (1).
2. Verwijder bovenste LED-lamp (2).

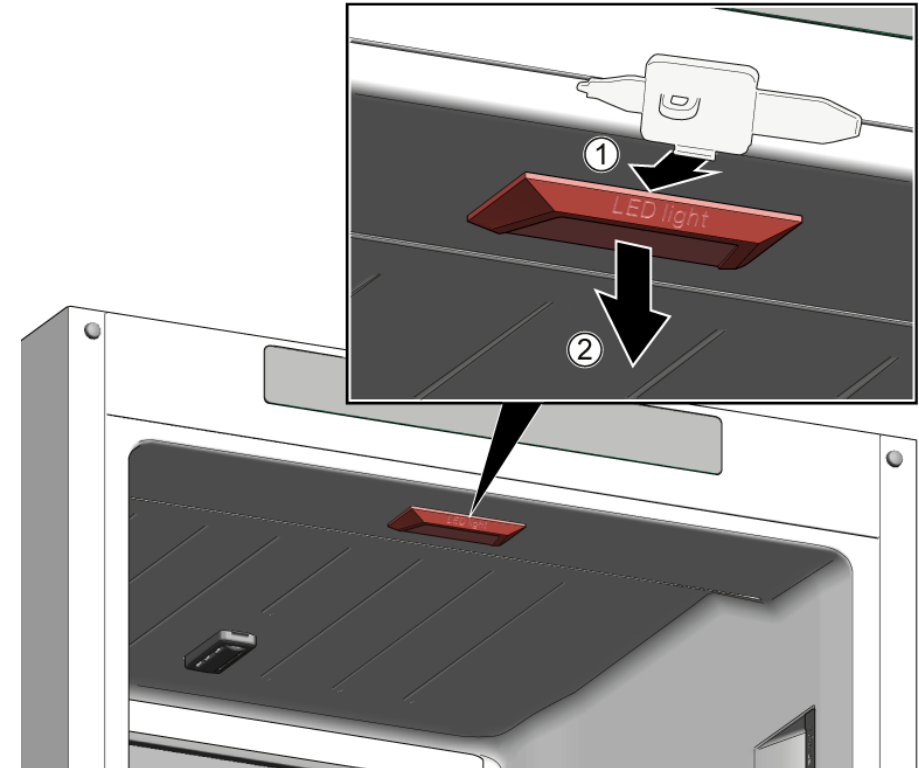

2. Haal de elektrische aansluiting van de bovenste LED-lamp los.
- ➡ De bovenste LED-lamp wordt verwijderd.

4.14.2 Bovenste LED-lamp monteren

- ▶ Monteer in omgekeerde volgorde.

4.15 LED-zijlamp vervangen

Speciale hulpmiddelen:

 Speciaal gereedschap

[00342180]

	<p>Uw apparaat heeft een onderhoudsvrije LED-lamp. Deze lampen mogen uitsluitend door de klantenservice of geautoriseerde monteurs worden vervangen!</p>
---	--



	<p> GEVAAR</p> <p>Gevaar voor een elektrische schok aan stroomvoerende onderdelen! Levensgevaar door elektrische schokken in geval van een ondeskundige reparatie</p> <ul style="list-style-type: none">▶ Elektrische onderdelen moeten door gekwalificeerde elektriciens worden gerepareerd.▶ Laat na de reparatie een veiligheidstest conform VDE 0701 of de landspecifieke regelgeving uitvoeren.
--	--

	<p> GEVAAR</p> <p>Gevaar voor een elektrische schok aan stroomvoerende onderdelen! Dood door elektrocutie</p> <ul style="list-style-type: none">▶ Haal apparaten minstens 60 seconden voor u met reparaties begint van de stroomvoorziening af.
--	--

	<p> VOORZICHTIG</p> <p>Scherpe randen! Snijletsel</p> <ul style="list-style-type: none">▶ Draag veiligheidshandschoenen.
--	---

	<p>LET OP!</p> <p>Gevaar voor schade aan electrostatisch gevoelige componenten (ESD's)! Schade aan componenten</p> <ul style="list-style-type: none">▶ Gebruik een electrostatisch beschermingsmiddel (aardingspoliband) voordat u ESD's aanraakt.▶ Raak geen aansluitingen en geleiderbanen van de modules aan.▶ Vervoer ESD's uitsluitend in geleidende materialen of in de oorspronkelijke verpakking.▶ Houd ESD's uit de buurt van mogelijk electrostatische materialen (zoals kunststof).
---	---

Voorwaarde:

-  Apparaat wordt van de stroomvoorziening afgehaald.
-  Deur is open.
-  Interieurdelen van het koelvak worden verwijderd.

4.15.1 LED-zijlamp verwijderen

1. Schuif het demontagegereedschap tussen de lampafdekking en de behuizing om de haak los te koppelen (1).
2. Haal de lampafdekking eruit (2).
3. Herhaal de stappen voor de resterende bevestigingshaken.

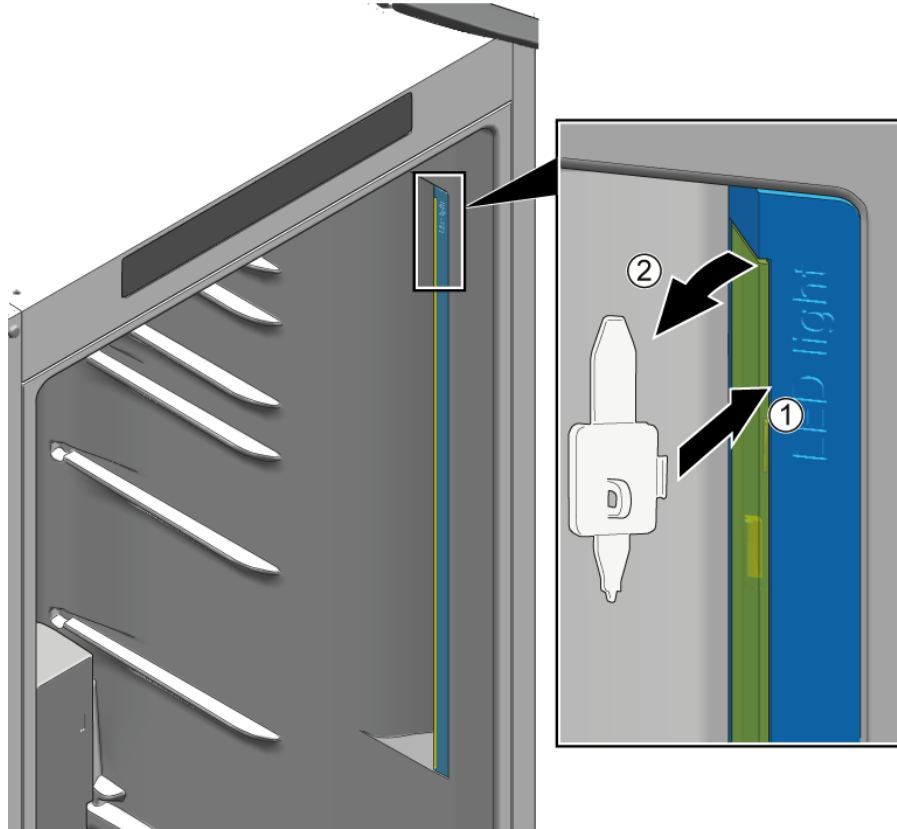

➡ De lampafdekking is verwijderd.

1. Druk op de bevestigingshaak om deze los te maken (1).
2. Beweeg de LED-module ca. 1 cm omhoog om de LED-module los uit het elektrische contact te halen (2).
3. Verwijder de LED-module (3).

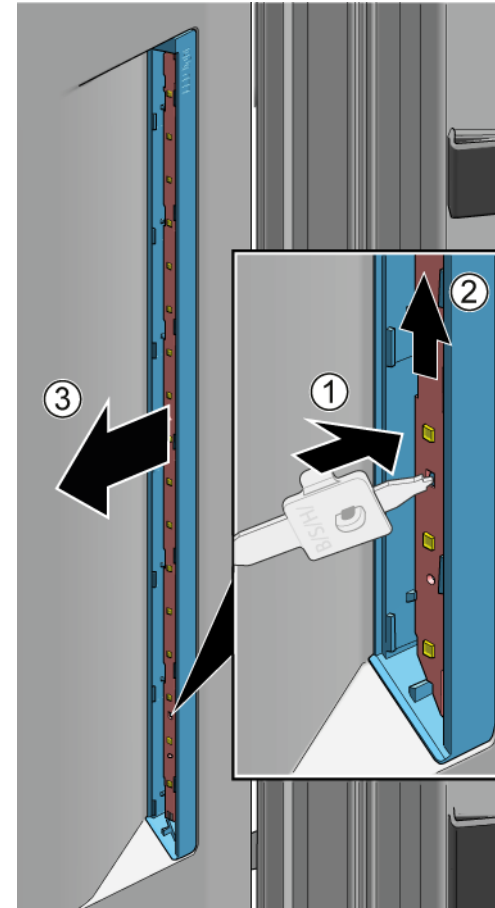

➡ De LED-zijlamp is verwijderd.

4.15.2 LED-zijlamp monteren



Door de lampafdekking kunnen haken gemakkelijk breken tijdens verwijdering. Het reserveonderdeel LED-zijlamp is de set die ook de LED-module en de lamp afdekking bevat.

Reparatie

1. Schuif het demontagegereedschap tussen de lampafdekking en de behuizing om de haak los te koppelen (1).
2. Haal de lampafdekking eruit (2).
3. Herhaal de stappen voor de resterende bevestigingshaken.

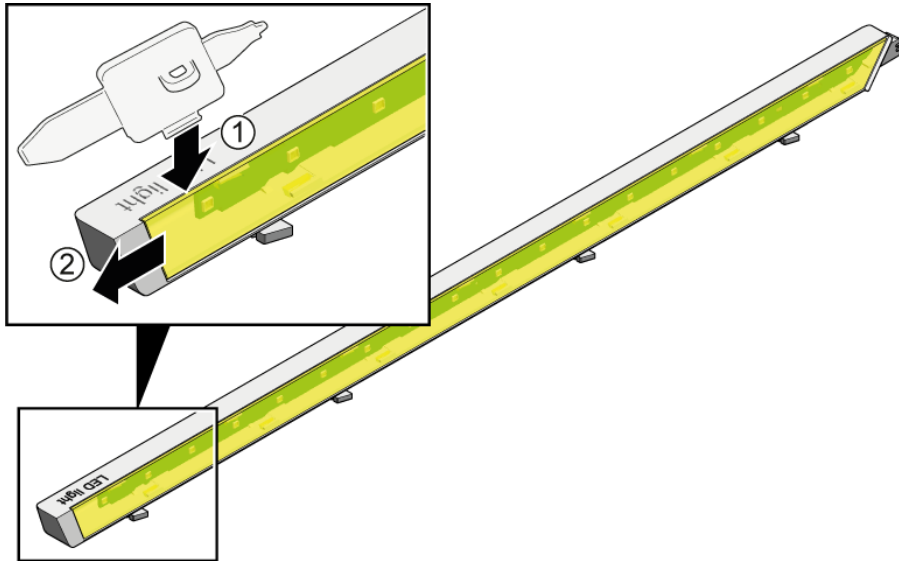

2. 1. Druk op de bevestigingshaak om deze los te maken (1).
2. Schuif de LED-module omhoog en uit de behuizing.
3. Reservebehuizing van de LED-module die wordt gebruikt voor de beveiliging tijdens het transporteren van reserveonderdelen (3).

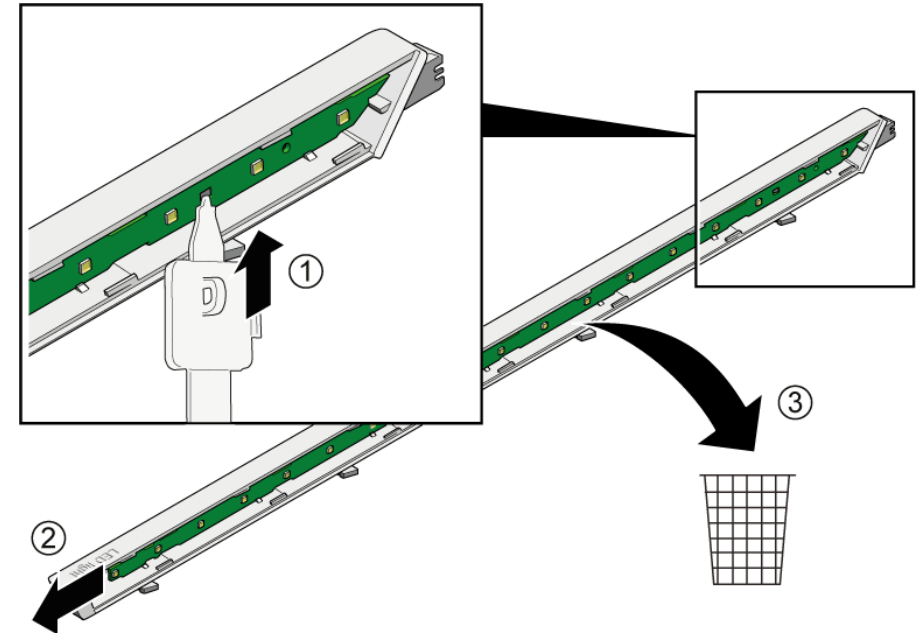

3. U installeert de LED-module en lampafdekking door de verwijderingsstappen in omgekeerde volgorde te doorlopen.

4.16 LED-vriesvaklamp vervangen

Speciale hulpmiddelen:

Speciaal gereedschap

[00342180]

i Uw apparaat heeft een onderhoudsvrije LED-lamp. Deze lampen mogen alleen maar door de klantenservice of geautoriseerde monteurs worden vervangen!

⚠ GEVAAR
Gevaar voor een elektrische schok aan stroomvoerende onderdelen!
 Levensgevaar door elektrische schokken in geval van een ondeskundige reparatie

- ▶ Elektrische onderdelen moeten door gekwalificeerde elektriciens worden gerepareerd.
- ▶ Laat na de reparatie een veiligheidstest conform VDE 0701 of de landspecifieke regelgeving uitvoeren.

⚠ GEVAAR
Gevaar voor een elektrische schok aan stroomvoerende onderdelen!
 Dood door elektrocutie

- ▶ Haal apparaten minstens 60 seconden voor u met reparaties begint van de stroomvoorziening af.

⚠ VOORZICHTIG
Scherpe randen!
 Snijletsel

- ▶ Draag veiligheidshandschoenen.

Voorwaarde:

- ✔ Apparaat wordt van de stroomvoorziening afgehaald.
- ✔ Deur is open.

4.16.1 LED-vriesvaklamp verwijderen

- ▶ 1. Schuif het demontagegereedschap tussen de lamp en de behuizing aan de zijkant van de lamp om een spleet te maken (1).
- ▶ 2. Schuif het demontagegereedschap naar de andere kant van de lampbevestigingshaak en draai het naar voren (2).
- ▶ 3. Verwijder de LED-vriesvaklamp (3).

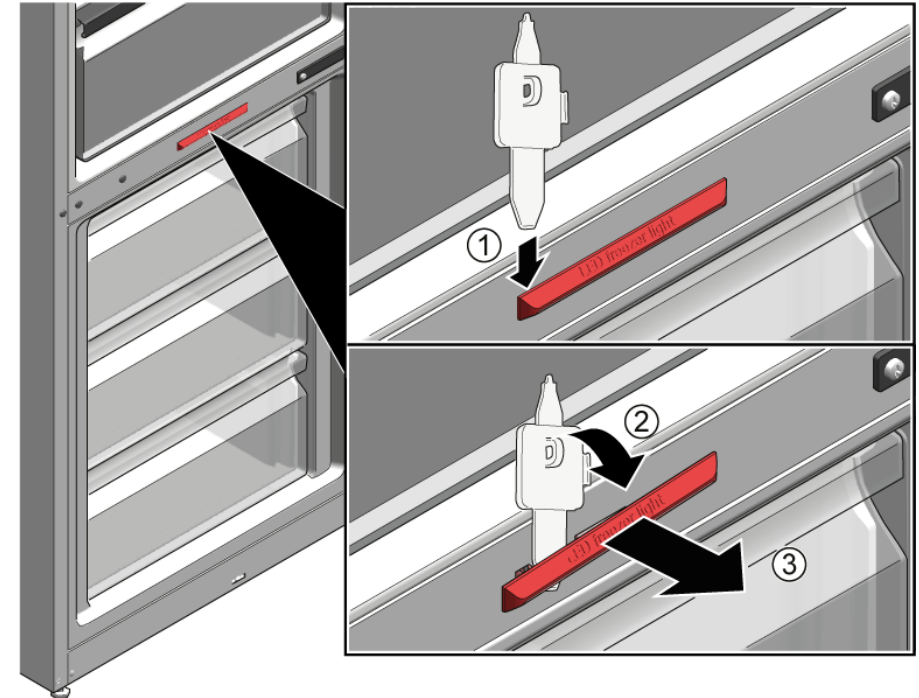





- ➡ LED-vriesvaklamp wordt losgehaald.
- ➡ De LED-vriesvaklamp wordt verwijderd.

4.16.2 LED-vriesvaklamp monteren

- ▶ Monteer in omgekeerde volgorde.

Self-repair hints - Fridge-freezer

 Concerning this document	152
1.1 Important information	152
1.1.1 Purpose.....	152
1.2 Explanation of symbols	152
1.2.1 Danger levels.....	152
1.2.2 Hazard symbols	152
1.2.3 Structure of the warnings.....	153
1.2.4 General symbols.....	153
 Safety	154
2.1 General Safety instructions	154
2.1.1 All domestic appliances	154
 Tools and aids	155
 Repair	156
4.1 Replacing door gasket	156
4.1.1 Removing door gasket.....	156
4.1.2 Installing door gasket	156
4.2 Replacing door handle	159
4.2.1 Removing door handle	159
4.2.2 Installing door handle	159
4.3 Replacing door upper hinge	160
4.3.1 Removing door upper hinge.....	160
4.3.2 Installing door upper hinge.....	161
4.4 Replacing door upper hinge (door with display)	162
4.4.1 Removing door upper hinge.....	162
4.4.2 Installing door upper hinge.....	163
4.5 Replacing door middle hinge	164
4.5.1 Removing door middle hinge	164
4.5.2 Installing door middle hinge	165
4.6 Replacing door lower hinge	166
4.6.1 Removing door lower hinge	166
4.6.2 Installing door lower hinge	166
4.7 Replacing shelf.....	167
4.7.1 Removing shelf.....	167
4.7.2 Installing shelf.....	167

4.8 Replacing bottle tray	168
4.8.1 Removing bottle tray.....	168
4.8.2 Installing bottle tray.....	168
4.9 Replacing door rack	169
4.9.1 Removing door rack.....	169
4.9.2 Installing door rack	169
4.10 Replacing storage container	170
4.10.1 Removing storage container.....	170
4.10.2 Installing storage container	170
4.11 Replacing fruit and vegetable container	171
4.11.1 Removing fruit and vegetable container	171
4.11.2 Installing fruit and vegetable container	171
4.12 Replacing shelf above the fruit and vegetable container	172
4.12.1 Removing shelf above the fruit and vegetable container.....	172
4.12.2 Installing shelf above the fruit and vegetable container	173
4.13 Replacing frozen food container.....	174
4.13.1 Removing frozen food container	174
4.13.2 Installing frozen food container	174
4.14 Replacing LED top lamp	175
4.14.1 Removing LED top lamp	175
4.14.2 Installing LED top lamp	175
4.15 Replacing LED side lamp	176
4.15.1 Removing LED side lamp.....	176
4.15.2 Installing LED side lamp.....	177
4.16 Replacing LED freezer lamp	179
4.16.1 Removing LED freezer lamp	179
4.16.2 Installing LED freezer lamp	179

i Concerning this document

1.1 Important information

1.1.1 Purpose

These repair hints support consumer to repair appliances by himself according to the applicable eco-design regulation (as of 03/2021).

They contain information how to exchange defined spare parts including warnings and risks.

In case of questions, please contact our customer service. We will only be liable for damages if the repair hints have been followed properly.

1.2 Explanation of symbols

1.2.1 Danger levels

The warning levels consist of a symbol and a signal word. The signal word indicates the severity of the danger.









Warning level	Meaning
	Non-observance of the warning message will result in death or serious injuries.
	Non-observance of the warning message could result in death or serious injuries.
	Non-observance of the warning message could result in minor injuries.
	Non-observance of the warning message could result in damage to property.

Table 1: Danger levels

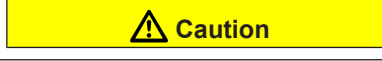
1.2.2 Hazard symbols

Hazard symbols are symbolic representations which give an indication of the kind of danger.

The following hazard symbols are used in this document:

Hazard symbol	Meaning
	General warning message
	Danger from electrical voltage
	Risk of explosion
	Danger of cuts
	Danger of crushing

i Concerning this document



Hazard symbol	Meaning
	Danger from hot surfaces
	Danger from strong magnetic field
	Danger from non-ionizing radiation

Table 2: Hazard symbols

1.2.3 Structure of the warnings

Warnings in this document have a standardised appearance and a standardised structure.



	<div style="background-color: red; color: white; padding: 2px; text-align: center;"> Danger</div> <p>Type and source of danger! Possible consequences of ignoring the danger / warning.</p> <ul style="list-style-type: none"> ▶ Measures and prohibitions for preventing the danger.
--	---

The following example shows a warning that warns against electric shock due to live parts. The measure for avoiding the danger is mentioned.

	<div style="background-color: red; color: white; padding: 2px; text-align: center;"> Danger</div> <p>Risk of electric shock due to live parts! Death by electrocution</p> <ul style="list-style-type: none"> ▶ Disconnect appliances from electrical supply at least 60 seconds before starting repairs.
---	---

1.2.4 General symbols

The following general symbols are used in this document:

Gen. symbol	Meaning
	Identification of a special tip (text and/or graphic)
	Identification of a simple tip (only text)
	Identification of a link to a video tutorial





Gen. symbol	Meaning
	Identification of required tools
	Identification of required preconditions
	Identification of a condition (if ..., then ...)
	Identification of a result
[Start]	Identification of a key or button
[00123456]	Identification of a material number
Status	Identification of displayed text / window (in the appliance's display)

Table 3: General symbols

2.1 General Safety instructions

2.1.1 All domestic appliances

Risk of electric shock due to live parts!

- Errors by repairs involving electrical components can lead to electrical shock!
- Disconnect the appliance from the mains for at least 60 seconds before starting work.
- After the repair have a safety test according VDE 0701 or country-specific regulations performed.

Risk of injury from sharp edges!

- Wear protective gloves.

Risk of crushing during repair, maintenance, troubleshooting and service due to heavy and moving components

- Wear protective shoes.
- Secure heavy components from falling down.
- Do not stick body parts into moving components.

Risk to the appliance's safety / function!

- Only use original spare parts.

Risk of damage to electrostatically sensitive components (ESDs)!

- Do not touch the modules, including connections and conductor paths.

Tools and aids

Designation	Details	Images
Torx Bit TX20 [00340865]	6,3 mm (1/4")	
Special tool [00342180]		

4.1 Replacing door gasket

Prerequisite:

-  Door is open.

4.1.1 Removing door gasket

1. Release door gasket from the groove on right and left corner.

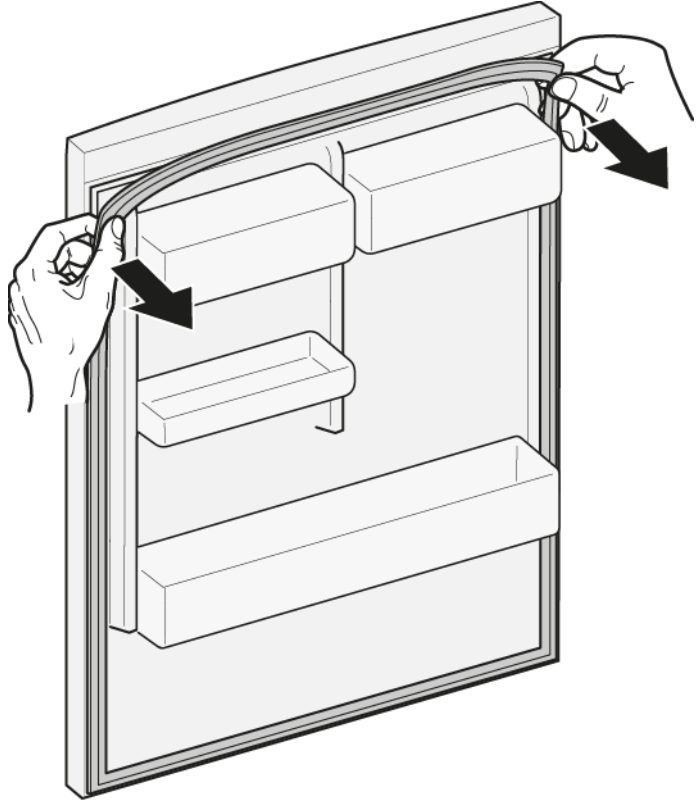

2. Pull out door gasket from groove.

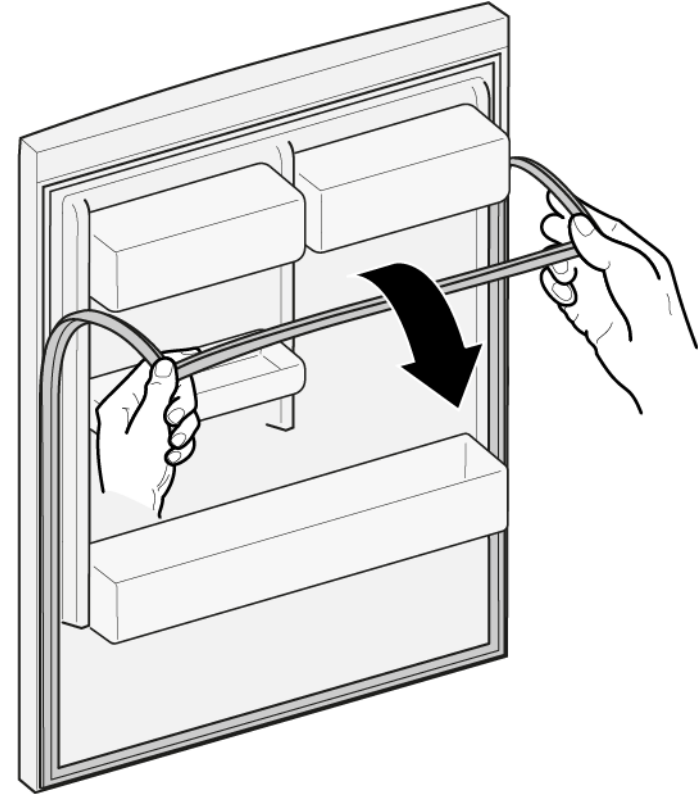

-  Door gasket is removed.

4.1.2 Installing door gasket



Thickness of new door gasket may deviate slightly from thickness of old door gasket. This will not affect closing behavior and long-term function. If your appliance has adjustable hinges or hinge attachments, you can optimize the closing behavior subsequently. Small side holes in door gasket are functional (required for ventilation). These are not production faults.

Repair

1. Check groove for gasket for damage.

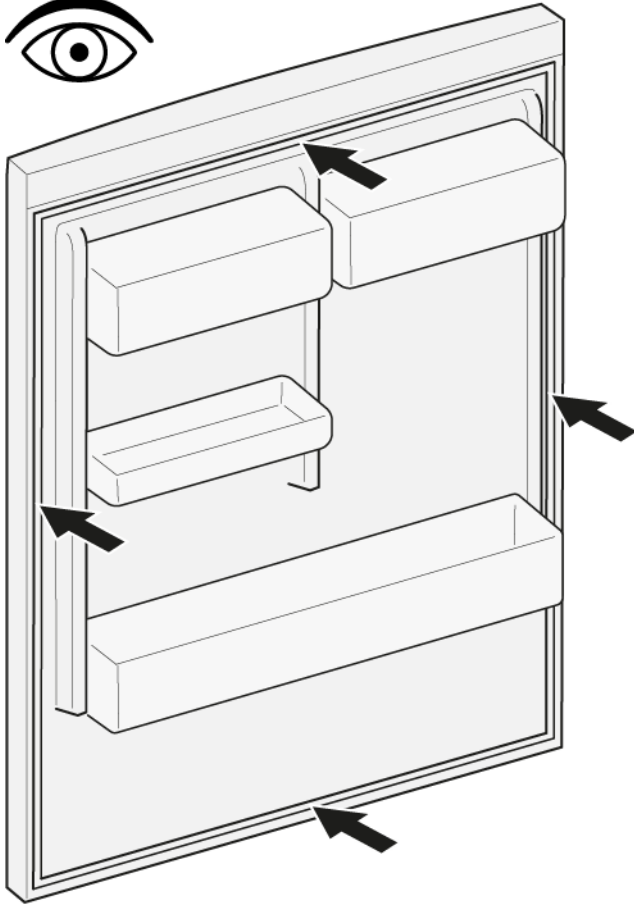

4. Push corners of gasket at the top and bottom to the groove.

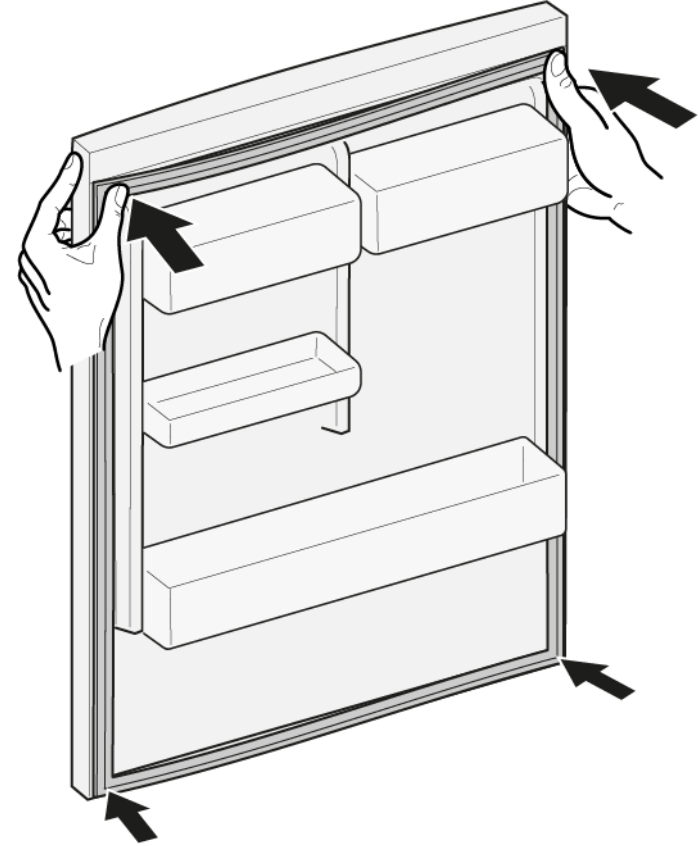

2.  If groove for gasket is it is damaged.
- Contact customer service.

3.  Slight deformation of door gasket is normal and does not affect its function. It is recommended to straighten door gasket before inserting it into appliance.

Heat door gasket with a hair dryer or hot water and manually reshape it.

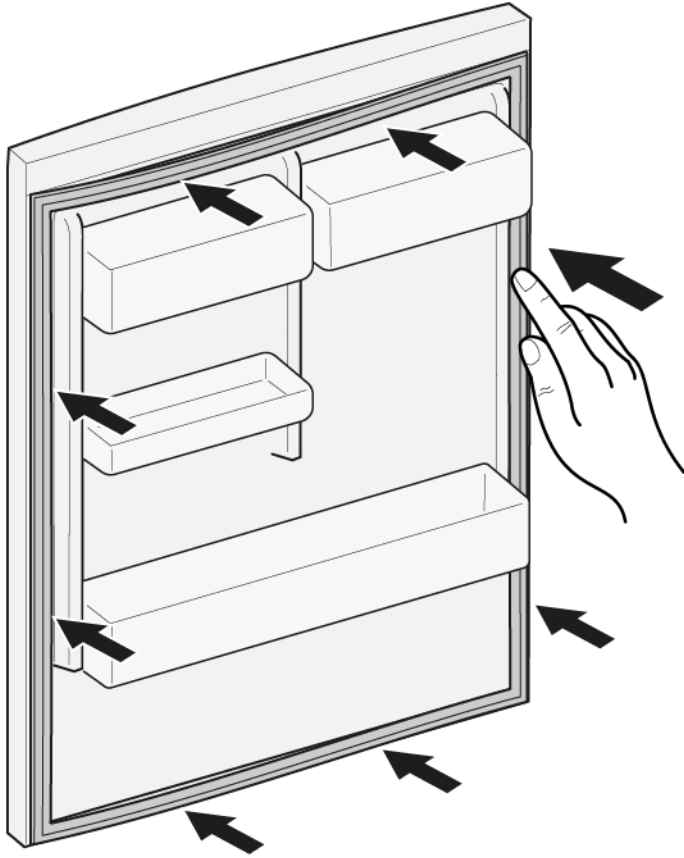

5. Press whole gasket step by step into the groove.





-  Door gasket is installed.

4.2 Replacing door handle

Required tools:

-  Torx Bit TX20 6,3 mm (1/4") [00340865]
-  Slotted screwdriver Blade 10 mm x 1.6 mm x 200 mm

Prerequisite:

-  Appliance is disconnected from power supply.
-  Door is open.

4.2.1 Removing door handle

- ▶ 1. Remove two screw caps (1).
- ▶ 2. Unscrew two screws (2).
- ▶ 3. Remove door handle (3).

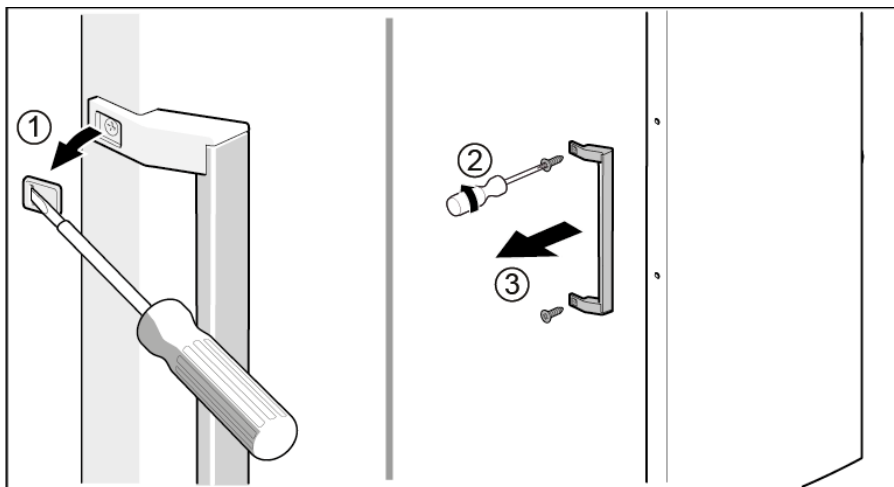

 Door handle is removed.



Door handle for the second door can be removed in the same manner.

4.2.2 Installing door handle

- ▶ Install in reverse order.

4.3 Replacing door upper hinge

Required tools:

 Torx Bit TX20 6,3 mm (1/4") [00340865]



Warning

Heavy, bulky appliances!

Back and muscle injuries

- ▶ Appliance door removal operation should only be carried out by trained specialists.
- ▶ To move the appliance, two people are required.
- ▶ Use only suitable tools and equipment.



Caution

Sharp edges!

Cut injuries

- ▶ Wear protective gloves.



Warning

Slipping of tilted appliances!

Bone fractures / crush injuries

- ▶ Secure appliances against slipping.



Caution

Risk of falling parts due to released screws!

Injury because of falling parts.

- ▶ Secure component from falling down.





Notice

Risk of falling parts due to released screws!

Damage to other parts of the appliance or at customers home e.g. bottom.

- ▶ Secure component from falling down.

Prerequisite:

-  Appliance is disconnected from power supply.
-  Appliance interior fittings are removed.

4.3.1 Removing door upper hinge

1. Slide supporting part under base section.

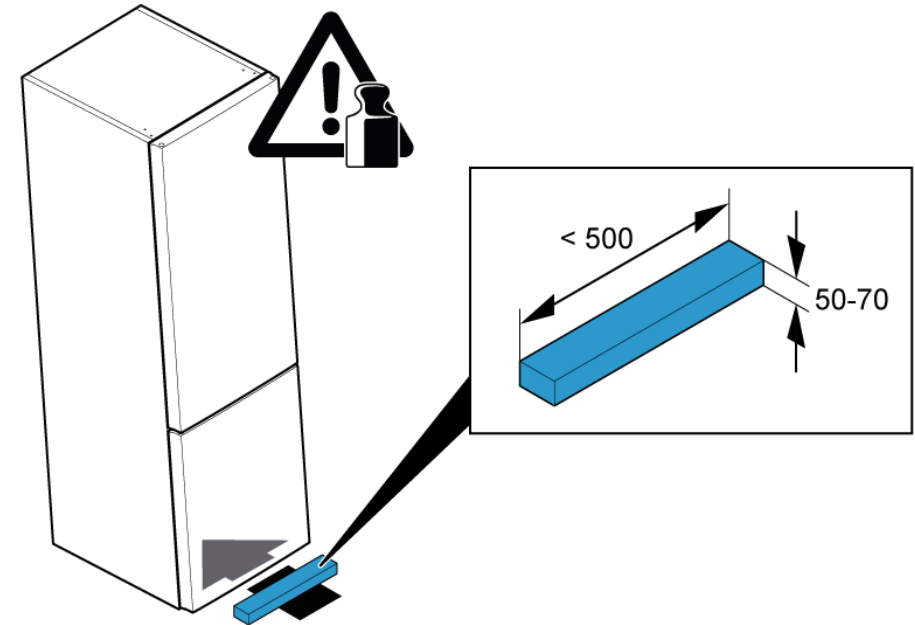

2. 1. Remove upper hinge cover (1).
2. Unscrew two screws (2).
3. Remove upper hinge (3).

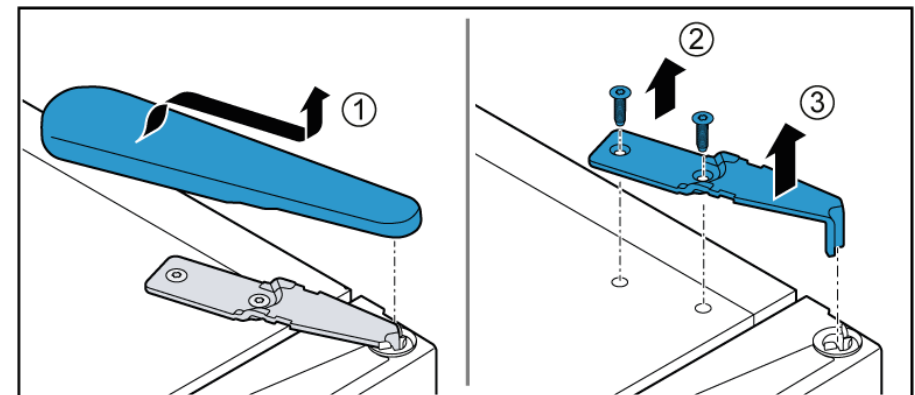

3. Remove upper door.

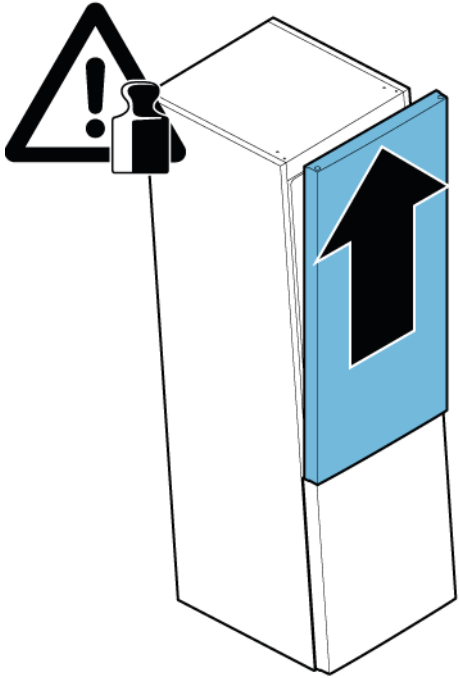

 Upper hinge is removed.

4.3.2 Installing door upper hinge

▶ Install in reverse order.

4.4 Replacing door upper hinge (door with display)

Required tools:

Torx Bit TX20 6,3 mm (1/4") [00340865]

	Warning
	<p>Heavy, bulky appliances! Back and muscle injuries</p> <ul style="list-style-type: none"> ▶ Appliance door removal operation should only be carried out by trained specialists. ▶ To move the appliance, two people are required. ▶ Use only suitable tools and equipment.

	Caution
	<p>Sharp edges! Cut injuries</p> <ul style="list-style-type: none"> ▶ Wear protective gloves.

	Warning
	<p>Slipping of tilted appliances! Bone fractures / crush injuries</p> <ul style="list-style-type: none"> ▶ Secure appliances against slipping.

	Caution
	<p>Risk of falling parts due to released screws! Injury because of falling parts.</p> <ul style="list-style-type: none"> ▶ Secure component from falling down.

	Notice
	<p>Risk of falling parts due to released screws! Damage to other parts of the appliance or at customers home e.g. bottom.</p> <ul style="list-style-type: none"> ▶ Secure component from falling down.

	Danger
	<p>Risk of electric shock due to live parts! Danger to life through electric shock in case of improper repair</p> <ul style="list-style-type: none"> ▶ Electric parts should be repaired by a qualified electricians. ▶ After the repair have a safety test according VDE 0701 or country-specific regulations performed.

	Danger
	<p>Risk of electric shock due to live parts! Death by electrocution</p> <ul style="list-style-type: none"> ▶ Disconnect appliances from electrical supply at least 60 seconds before starting repairs.

Prerequisite:

- ✓ Appliance is disconnected from power supply.
- ✓ Appliance interior fittings are removed.

4.4.1 Removing door upper hinge

- Slide supporting part under base section.

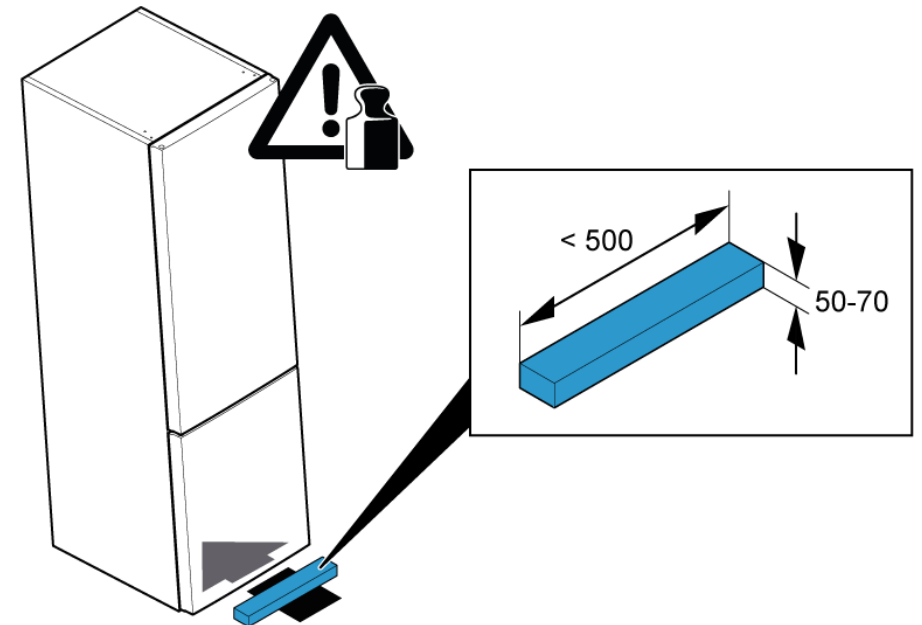

Repair

2. 1. Remove upper hinge cover (1).
2. Disconnect electrical connection (2).
3. Unscrew ground connection screw (3).

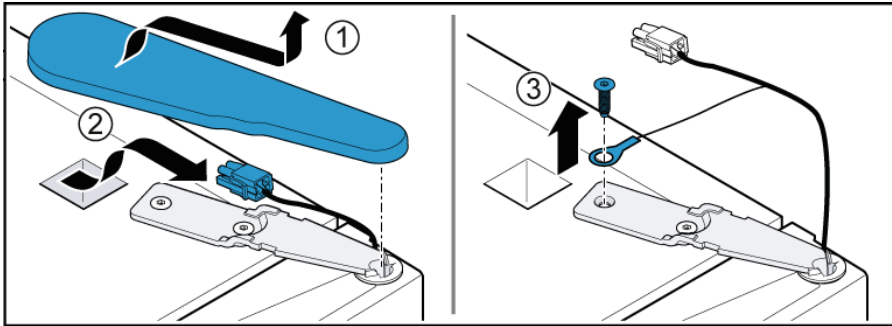

3. 1. Unscrew the screw (1).
2. Remove upper hinge (2).

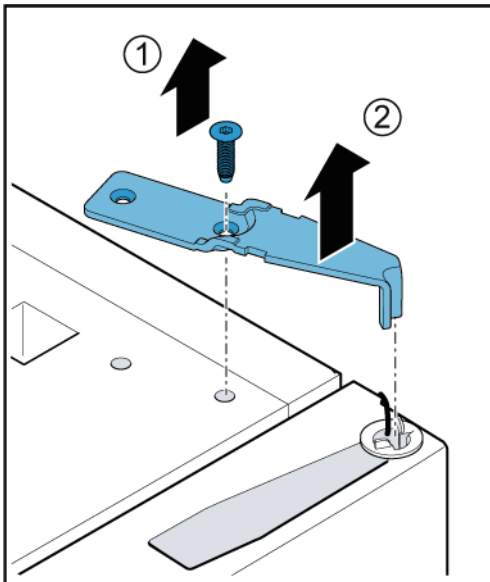

4. Remove upper door.

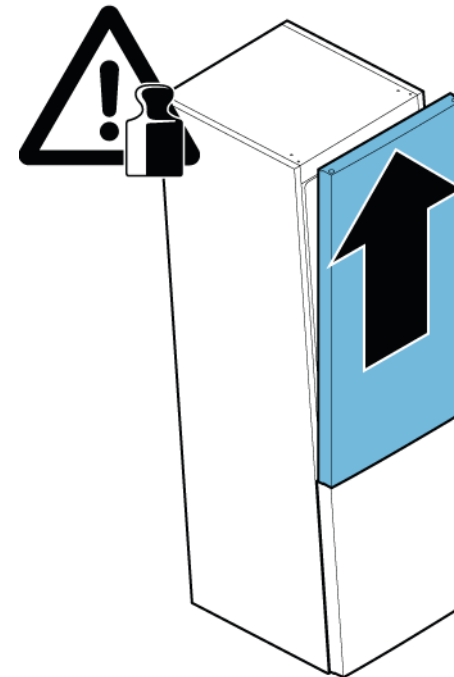

➡ Upper hinge is removed.

4.4.2 Installing door upper hinge

- ▶ Install in reverse order.

4.5 Replacing door middle hinge

Required tools:

 Torx Bit TX20 6,3 mm (1/4") [00340865]

	Warning
	<p>Heavy, bulky appliances! Back and muscle injuries</p> <ul style="list-style-type: none"> ▶ Appliance door removal operation should only be carried out by trained specialists. ▶ To move the appliance, two people are required. ▶ Use only suitable tools and equipment.



	Caution
	<p>Sharp edges! Cut injuries</p> <ul style="list-style-type: none"> ▶ Wear protective gloves.

	Warning
	<p>Slipping of tilted appliances! Bone fractures / crush injuries</p> <ul style="list-style-type: none"> ▶ Secure appliances against slipping.

	Caution
	<p>Risk of falling parts due to released screws! Injury because of falling parts.</p> <ul style="list-style-type: none"> ▶ Secure component from falling down.

	Notice
	<p>Risk of falling parts due to released screws! Damage to other parts of the appliance or at customers home e.g. bottom.</p> <ul style="list-style-type: none"> ▶ Secure component from falling down.

Prerequisite:

-  Appliance is disconnected from power supply.
-  Appliance interior fittings are removed.
-  Door upper hinge is removed.

 Upper door is removed.

4.5.1 Removing door middle hinge

1. 1. Unscrew two screws (1).
2. 2. Remove middle hinge (2).

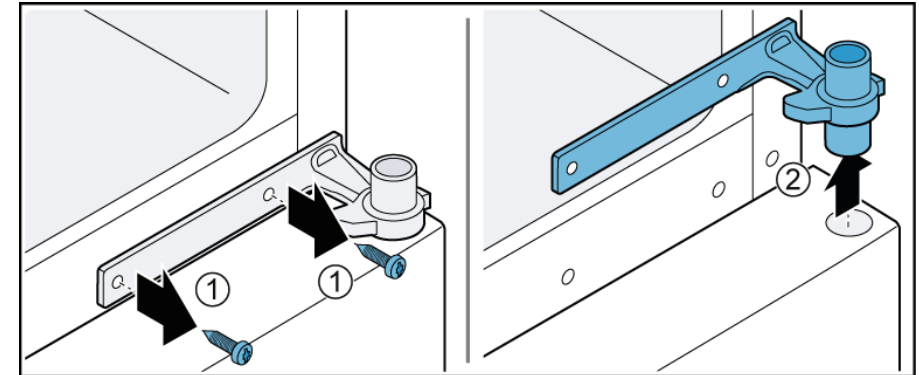

2. Remove lower door.

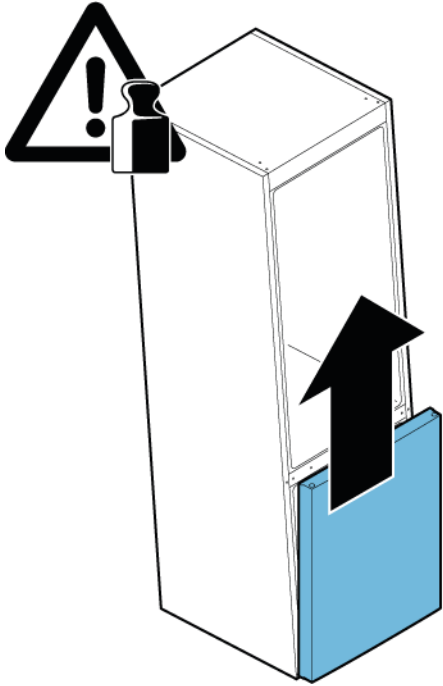

➡ Middle hinge is removed.





4.5.2 Installing door middle hinge

▶ Install in reverse order.



4.6 Replacing door lower hinge

Required tools:

 Torx Bit TX20 6,3 mm (1/4") [00340865]

	Warning
	<p>Heavy, bulky appliances! Back and muscle injuries</p> <ul style="list-style-type: none"> ▶ Appliance door removal operation should only be carried out by trained specialists. ▶ To move the appliance, two people are required. ▶ Use only suitable tools and equipment.
	Caution
	<p>Sharp edges! Cut injuries</p> <ul style="list-style-type: none"> ▶ Wear protective gloves.
	Warning
	<p>Slipping of tilted appliances! Bone fractures / crush injuries</p> <ul style="list-style-type: none"> ▶ Secure appliances against slipping.
	Caution
	<p>Risk of falling parts due to released screws! Injury because of falling parts.</p> <ul style="list-style-type: none"> ▶ Secure component from falling down.
	Notice
	<p>Risk of falling parts due to released screws! Damage to other parts of the appliance or at customers home e.g. bottom.</p> <ul style="list-style-type: none"> ▶ Secure component from falling down.

Prerequisite:

-  Appliance is disconnected from power supply.
-  Appliance interior fittings are removed.
-  Upper hinge is removed.

 Middle hinge is removed.

4.6.1 Removing door lower hinge

- ▶ 1. Unscrew two screws (1).
- ▶ 2. Remove lower hinge (2).

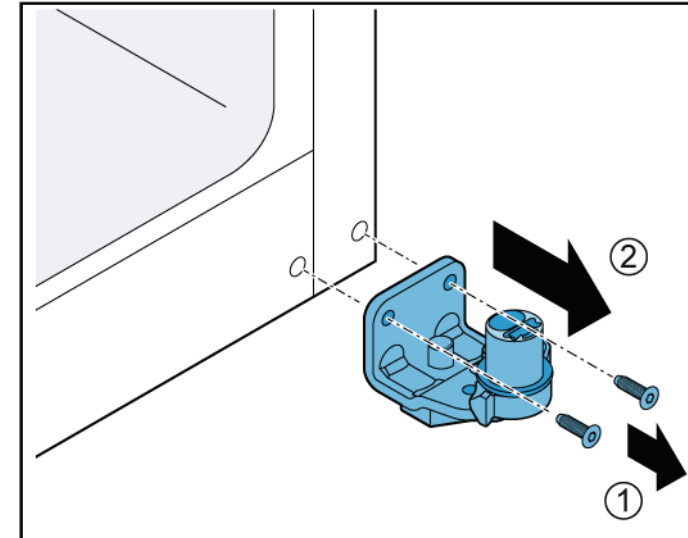

 Door lower hinge is removed.

4.6.2 Installing door lower hinge

- ▶ Install in reverse order.

4.7 Replacing shelf

Prerequisite:

- ✔ Door is open.

4.7.1 Removing shelf

- ▶ 1. Lift the shelf at the rear (1).
- ▶ 2. Release shelf (2).

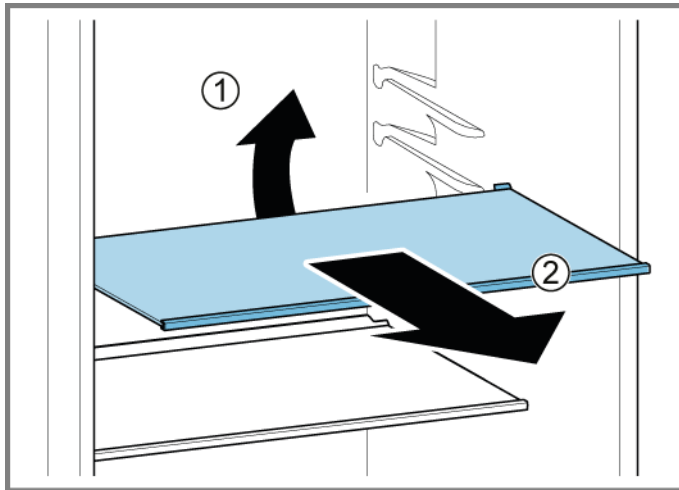

➡ Shelf is removed.

4.7.2 Installing shelf

- ▶ Install in reverse order.

4.8 Replacing bottle tray

Prerequisite:

- ✔ Door is open.

4.8.1 Removing bottle tray

- ▶ Pull out bottle tray.

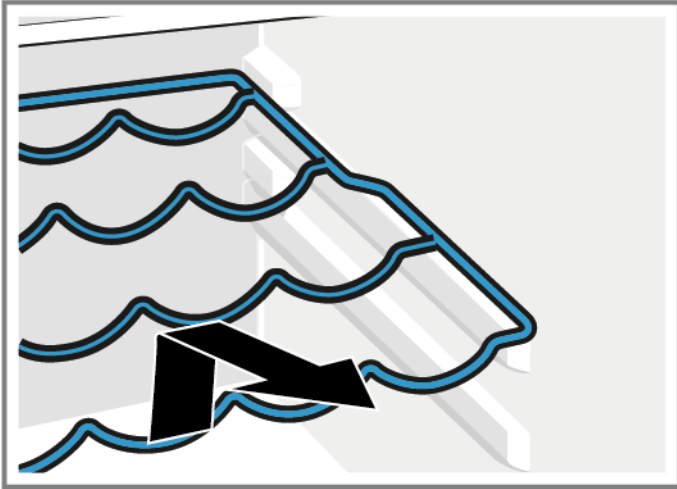

- ➡ Bottle tray is removed.

4.8.2 Installing bottle tray

- ▶ Install in reverse order.

4.9 Replacing door rack

Prerequisite:

- ✔ Door is open.

4.9.1 Removing door rack

- ▶ Lift door rack upwards.

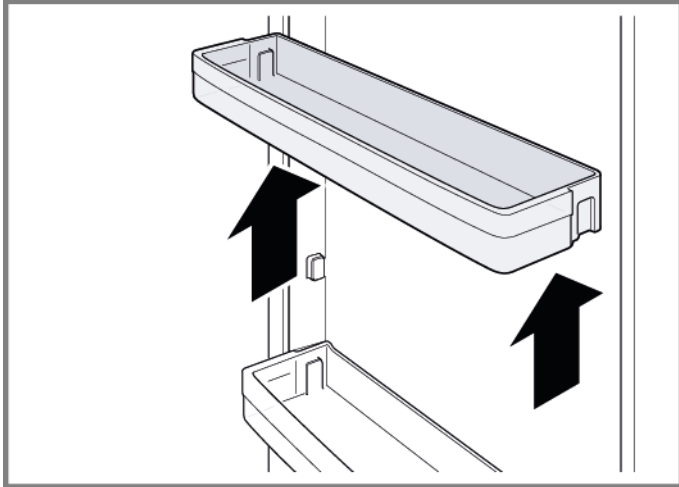

- ➡ Door rack is removed.

4.9.2 Installing door rack

- ▶ Install in reverse order.

4.10 Replacing storage container

Prerequisite:

- ✔ Door is open.

4.10.1 Removing storage container

1. Pull out the storage container as far as it will go.
2. 1. Lift the storage container at the front (1).
2. Remove container (2).

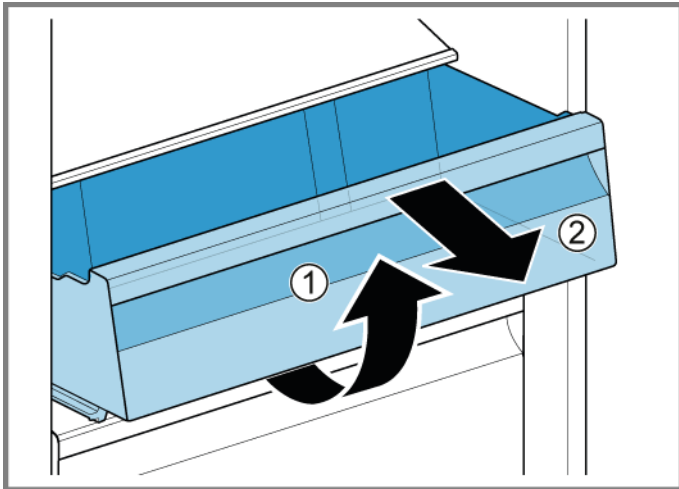

- ➔ Storage container is removed.

4.10.2 Installing storage container

- ▶ Install in reverse order.

4.11 Replacing fruit and vegetable container

Prerequisite:

- ✔ Door is open.

4.11.1 Removing fruit and vegetable container

1. Pull out the fruit and vegetable container as far as it will go.
2. 1. Lift the fruit and vegetable container at the front (1).
2. Remove container (2).



- ➡ Fruit and vegetable container is removed.

4.11.2 Installing fruit and vegetable container

- ▶ Install in reverse order.

4.12 Replacing shelf above the fruit and vegetable container

Prerequisite:

- ✔ Door is open.
- ✔ [Fruit and vegetable container is removed.](#) → [Page 171](#)

4.12.1 Removing shelf above the fruit and vegetable container

1. Push the sealing frame upwards and out.

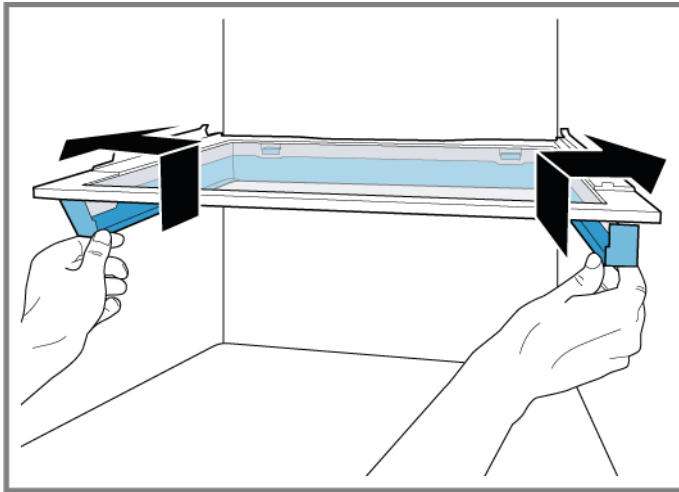

- ➡ Side hooks are released.

2. Lift up the sealing frame and slide it backwards.

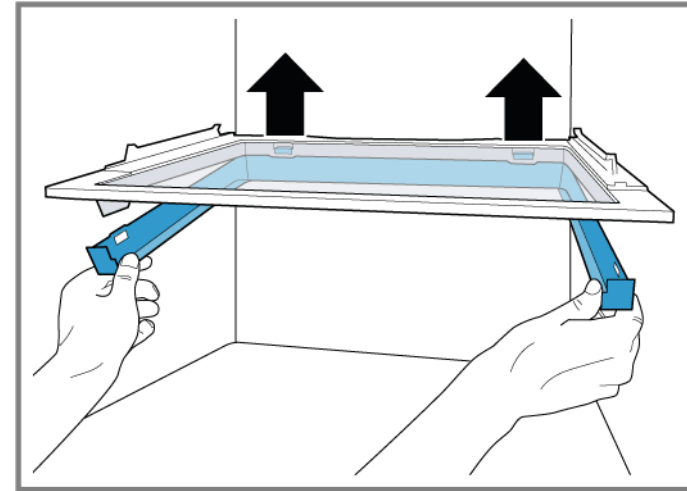

- ➡ Rear hooks are released.

3. Remove the sealing frame.
4. Lift up the shelf above the fruit and vegetable container and swivel it out to the side.

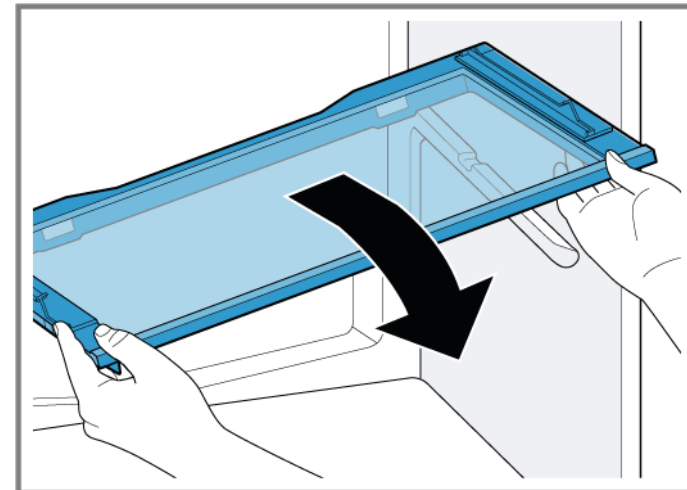

- ➡ Shelf above the fruit and vegetable container is removed.

4.12.2 Installing shelf above the fruit and vegetable container

- ▶ Install in reverse order.

4.13 Replacing frozen food container

Prerequisite:

- ✔ Door is open.

4.13.1 Removing frozen food container

- ▶ 1. Pull out frozen food container all the way (1).
- ▶ 2. Remove food container (2).

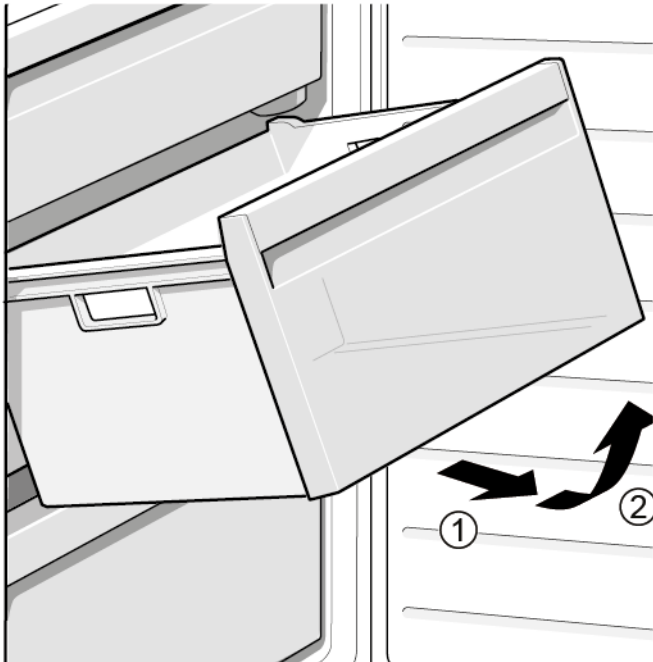

- ➡ Frozen food container is removed.

4.13.2 Installing frozen food container

- ▶ Install in reverse order.

4.14 Replacing LED top lamp

Required tools:

Special tool

[00342180]



Your appliance features a maintenance-free LED light.
These lights may be repaired by customer service or authorised technicians only!



Danger

Risk of electric shock due to live parts!

Danger to life through electric shock in case of improper repair

- ▶ Electric parts should be repaired by a qualified electrician.
- ▶ After the repair have a safety test according to VDE 0701 or country-specific regulations performed.



Danger

Risk of electric shock due to live parts!

Death by electrocution

- ▶ Disconnect appliances from electrical supply at least 60 seconds before starting repairs.



Caution

Sharp edges!

Cut injuries

- ▶ Wear protective gloves.

Prerequisite:

- ✓ Appliance is disconnected from power supply.
- ✓ Door is open.

4.14.1 Removing LED top lamp

1. Slide disassembly tool between LED top lamp and refrigerator compartment innerliner to release lamp hooks (1).
2. Remove LED top lamp (2).

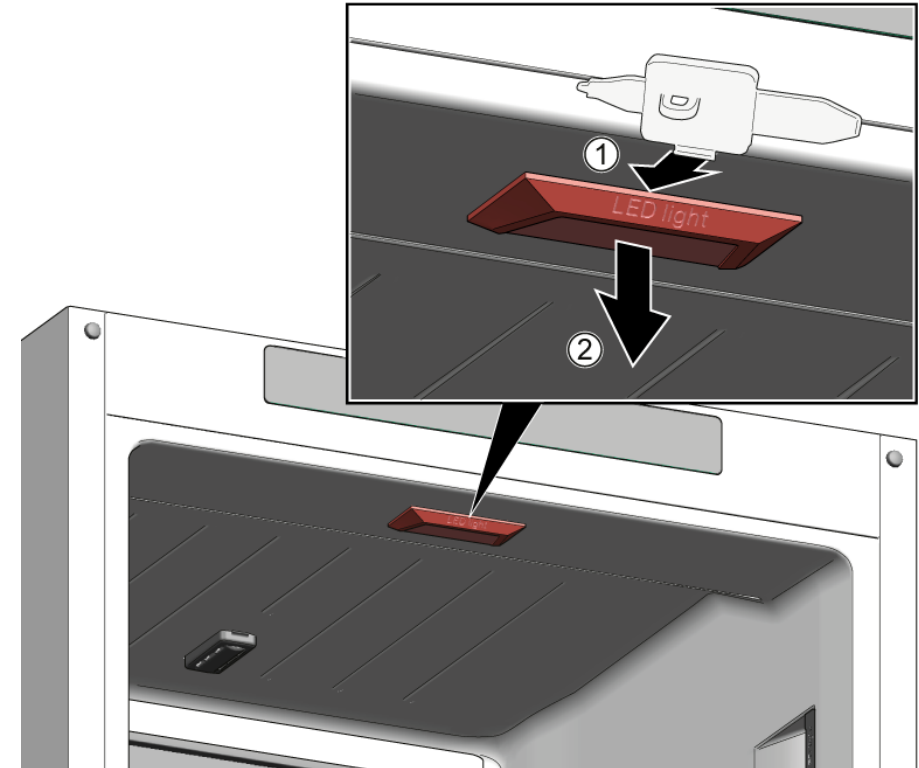

2. Disconnect LED top lamp electrical connection.
- ➡ LED top lamp is removed.

4.14.2 Installing LED top lamp

- ▶ Install in reverse order.

4.15 Replacing LED side lamp

Required tools:

Special tool [00342180]

i Your appliance features a maintenance-free LED light. These lights may be repaired by customer service or authorised technicians only!

⚠ Danger
Risk of electric shock due to live parts!
 Danger to life through electric shock in case of improper repair

- ▶ Electric parts should be repaired by a qualified electrician.
- ▶ After the repair have a safety test according to VDE 0701 or country-specific regulations performed.

⚠ Danger
Risk of electric shock due to live parts!
 Death by electrocution

- ▶ Disconnect appliances from electrical supply at least 60 seconds before starting repairs.

⚠ Caution
Sharp edges!
 Cut injuries

- ▶ Wear protective gloves.

⚠ Notice
Risk of damage to electrostatically sensitive components (ESDs)!
 Components damage

- ▶ Before touching ESDs, use an electrostatic protection system (wristband with earth safe plug).
- ▶ Do not touch connections and conductor paths of the modules.
- ▶ Only transport ESDs in conductive materials or original packaging.
- ▶ Keep ESDs clear of electrostatically chargeable materials (i.e. plastic).

Prerequisite:

- ✓ Appliance is disconnected from power supply.
- ✓ Door is open.

✓ RC interior fittings are removed.

4.15.1 Removing LED side lamp

1. Slide disassembly tool between lamp diffuser and housing to release hook (1).
2. Move out lamp diffuser (2).
3. Release succeeding diffuser fixation hooks in the same manner.

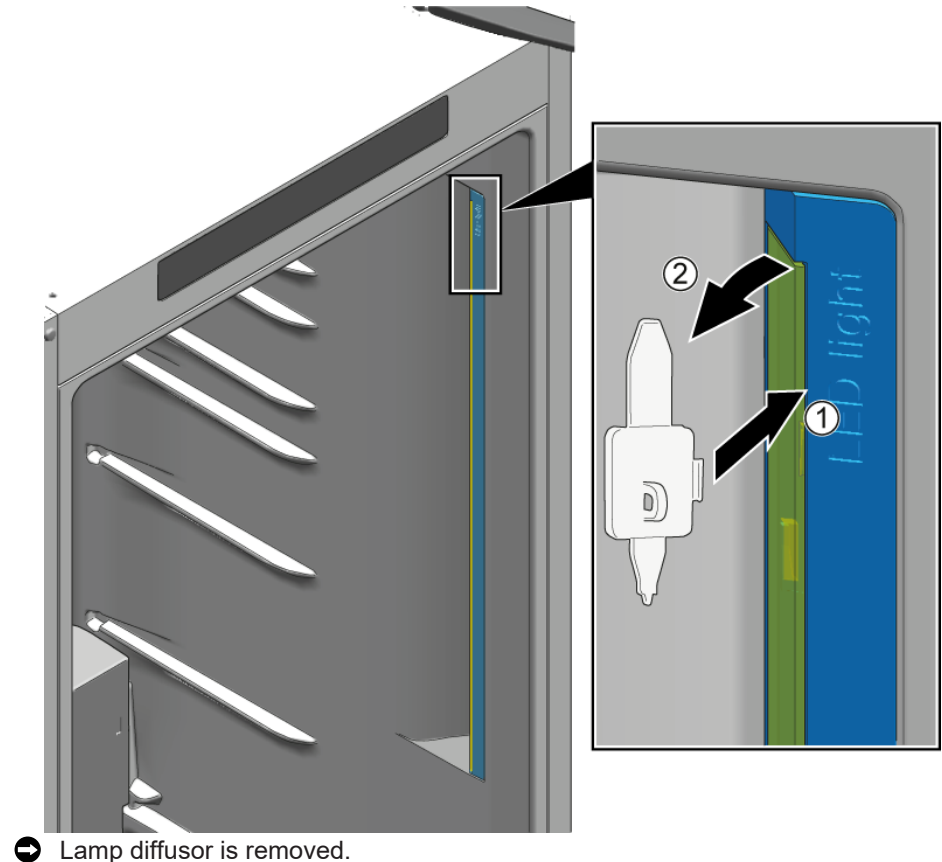

Repair

1. Press fixation hook to release it (1).
2. Move LED module up approx. 1 cm to remove to disconnect it from electrical socket (2).
3. Remove LED module (3).

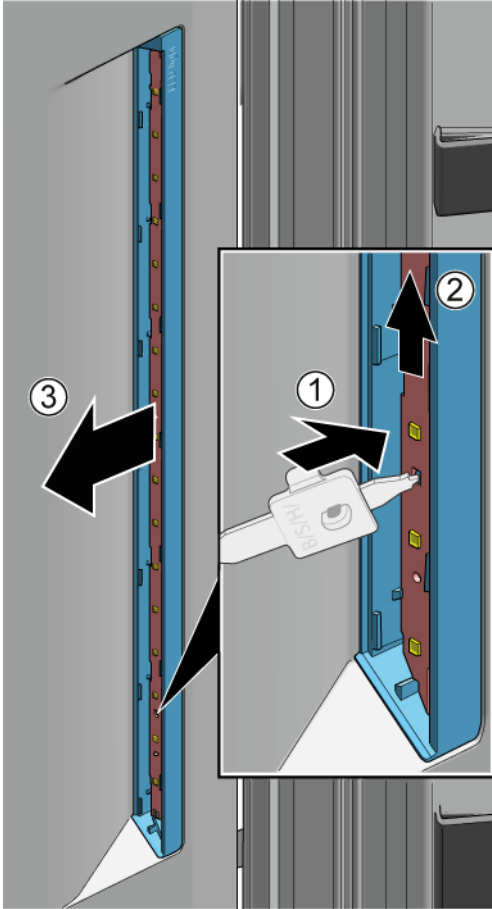

 LED side lamp is removed.

4.15.2 Installing LED side lamp



Due to lamp diffuser hooks are easy to break during removal process, spare part LED side lamp is the set that includes LED module and lamp diffuser.

1. Slide disassembly tool between lamp diffuser and housing to release hook (1).
2. Move out lamp diffuser (2).
3. Release succeeding diffuser fixation hooks in the same manner.

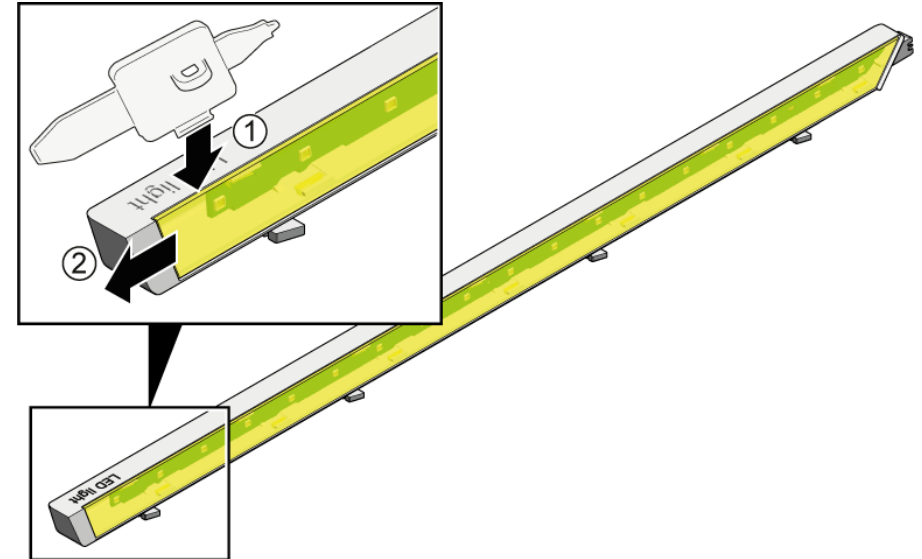

Repair

2. 1. Press fixation hook to release it (1).
2. Slide LED module up out the housing.
3. Scrap LED module housing that is used for spare part transportation security reasons (3).

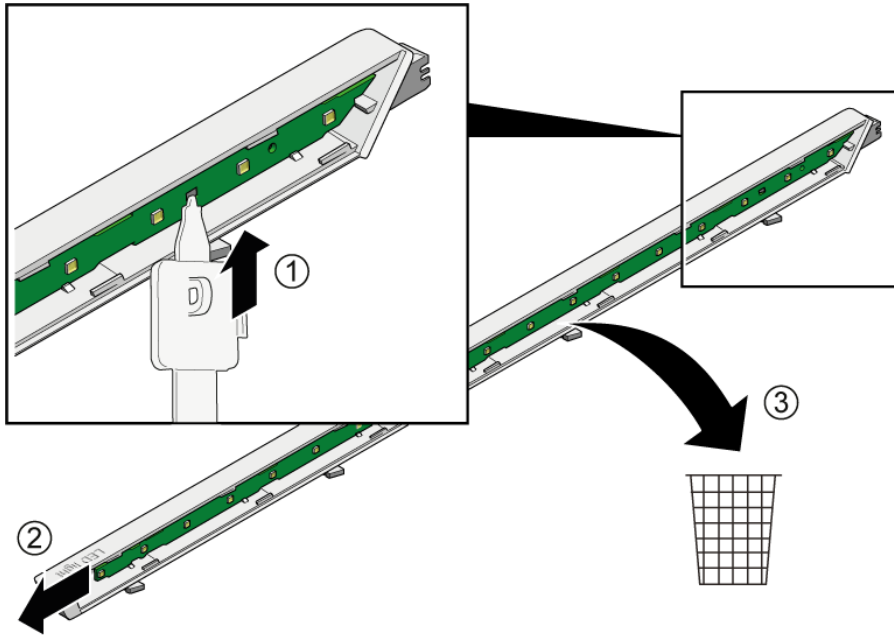

3. Install LED module and lamp diffuser in reverse order to removal.

4.16 Replacing LED freezer lamp

Required tools:

Special tool [00342180]

i Your appliance features a maintenance-free LED light. These lights may be repaired by customer service or authorised technicians only!

⚠ Danger
Risk of electric shock due to live parts!
 Danger to life through electric shock in case of improper repair

- ▶ Electric parts should be repaired by a qualified electrician.
- ▶ After the repair have a safety test according to VDE 0701 or country-specific regulations performed.

⚠ Danger
Risk of electric shock due to live parts!
 Death by electrocution

- ▶ Disconnect appliances from electrical supply at least 60 seconds before starting repairs.

⚠ Caution
Sharp edges!
 Cut injuries

- ▶ Wear protective gloves.

Prerequisite:

- ✓ Appliance is disconnected from power supply.
- ✓ Door is open.

4.16.1 Removing LED freezer lamp

- ▶ 1. Slide disassembly tool between lamp and housing at the side of lamp to create gap (1).
- ▶ 2. Slide disassembly tool on the other side of lamp fixation hook and rotate it forward (2).
- ▶ 3. Remove LED freezer lamp (3).

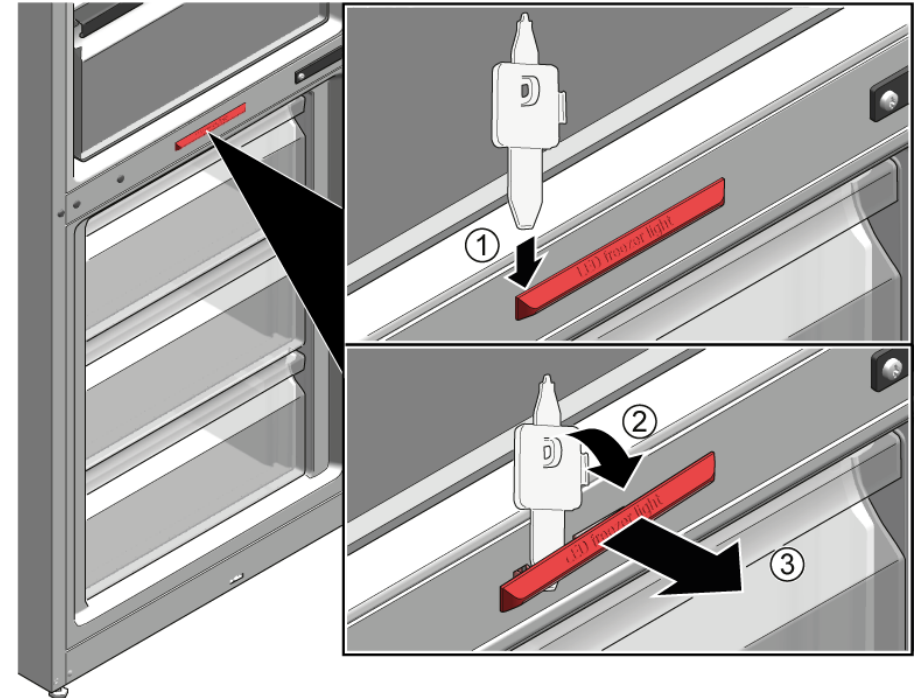

- ➡ LED freezer lamp is disconnected.
- ➡ LED freezer lamp is removed.

4.16.2 Installing LED freezer lamp

- ▶ Install in reverse order.

Remonditeave - Kombikülmik

 Selle dokumendiga seoses	181
1.1 Tähtis teave	181
1.1.1 Eesmärk.....	181
1.2 Sümbolite selgitus	181
1.2.1 Ohutasemed.....	181
1.2.2 Ohusümbolid	181
1.2.3 Hoiatuste struktuur.....	182
1.2.4 Üldised sümbolid.....	182
 Ohutus.....	183
2.1 Üldised ohutusjuhised.....	183
2.1.1 Kõik kodumasinad.....	183
 Tööriistad ja abinõud.....	184
 Remont.....	185
4.1 Uksetihendi vahetamine.....	185
4.1.1 Uksetihendi eemaldamine	185
4.1.2 Uksetihendi paigaldamine.....	185
4.2 Käepideme vahetamine	188
4.2.1 Käepideme eemaldamine	188
4.2.2 Käepideme paigaldamine	188
4.3 Ülemise uksehinge vahetamine	189
4.3.1 Ülemise uksehinge eemaldamine.....	189
4.3.2 Ülemise uksehinge paigaldamine.....	190
4.4 Ülemise uksehinge vahetamine (üks koos kuvaga).....	191
4.4.1 Ülemise uksehinge eemaldamine.....	191
4.4.2 Ülemise uksehinge paigaldamine.....	192
4.5 Keskmise uksehinge vahetamine.....	193
4.5.1 Keskmise uksehinge eemaldamine	193
4.5.2 Keskmise uksehinge paigaldamine	194
4.6 Alumise uksehinge vahetamine	195
4.6.1 Alumise uksehinge eemaldamine.....	195
4.6.2 Alumise uksehinge paigaldamine	195
4.7 Riiuli vahetamine	196
4.7.1 Riiuli eemaldamine.....	196
4.7.2 Riiuli paigaldamine	196

4.8 Pudelialuse vahetamine	197
4.8.1 Pudelialuse eemaldamine	197
4.8.2 Pudelialuse paigaldamine	197
4.9 Ukseraami vahetamine.....	198
4.9.1 Ukseraami eemaldamine	198
4.9.2 Ukseraami paigaldamine.....	198
4.10 Hoiumahuti vahetamine.....	199
4.10.1 Hoiumahuti eemaldamine	199
4.10.2 Hoiumahuti paigaldamine.....	199
4.11 Puu- ja köögiviljamahuti vahetamine	200
4.11.1 Puu- ja köögiviljamahuti eemaldamine	200
4.11.2 Puu- ja köögiviljamahuti paigaldamine	200
4.12 Puu- ja köögiviljamahuti kohal oleva riiuli vahetamine.....	201
4.12.1 Puu- ja köögiviljamahuti kohal oleva riiuli eemaldamine	201
4.12.2 Puu- ja köögiviljamahuti kohal oleva riiuli paigaldamine	202
4.13 Külmutatud toidu mahuti vahetamine.....	203
4.13.1 Külmutatud toidu mahuti eemaldamine	203
4.13.2 Külmutatud toidu mahuti paigaldamine	203
4.14 Ülemise LED-lambi vahetamine	204
4.14.1 Ülemise LED-lambi eemaldamine.....	204
4.14.2 Ülemise LED-lambi paigaldamine	204
4.15 Külgmise LED-lambi vahetamine	205
4.15.1 Külgmise LED-lambi eemaldamine	205
4.15.2 Külgmise LED-lambi paigaldamine	206
4.16 Külmiku LED-lambi vahetamine	208
4.16.1 Külmiku LED-lambi eemaldamine	208
4.16.2 Külmiku LED-lambi paigaldamine	208

i Selle dokumendiga seoses

1.1 Tähtis teave

1.1.1 Eesmärk

Need remondinõuanded toetavad tarbijat seadmete iseseisval remontimisel vastavalt kehtivale ökodisaini määrusele (03/2021).





Need sisaldavad teavet selle kohta, kuidas vahetada teatud varuosi, samuti hoiatusi ning ohtusid.

Küsimuste korral võtke ühendust meie klienditeenindusega. Meie vastutame kahjustuste eest ainult siis, kui remondinõuandeid on õigesti järgitud.

1.2 Sümbolite selgitus

1.2.1 Ohutasemed

Ohutasemed koosnevad sümbolist ja märksõnast. Märksõna viitab ohu raskusastmele.

Hoiatustase	Tähendus
 OHT	Hoiatusteadete eiramine põhjustab surma või raskeid kehavigastusi.
 HOIATUS	Hoiatusteadete eiramine võib põhjustada surma või raskeid kehavigastusi.
 ETTEVAATUST!	Hoiatusteadete eiramine võib põhjustada kergeid kehavigastusi.
 TÄHELEPANU!	Hoiatusteadete eiramine võib põhjustada varakahju.

Tabel 1: Ohutasemed



1.2.2 Ohusümbolid

Ohusümbolid on sümboolsed kujutised, mis viitavad ohu laadile.

Selles dokumendis kasutatakse alljärgnevaid ohusümboleid.

Ohusümbol	Tähendus
	Üldine ohuteade
	Elektripingest tingitud oht
	Plahvatusoht
	Lõikeoht
	Muljumisoht

i Selle dokumendiga seoses

Ohusümbol	Tähendus
	Kuumadest pindadest tingitud oht
	Tugevast magnetväljast tingitud oht
	Mitteioniseerivast kiirgusest tingitud oht

Tabel 2: Ohusümbolid

1.2.3 Hoiatuste struktuur

Selles dokumendis olevatel hoiatustel on standardiseeritud väljanägemine ja standardiseeritud struktuur.



	<div style="background-color: red; color: white; padding: 2px; display: inline-block;">⚠ OHT</div> Ohu tüüp ja allikas! Ohu/hoiatuse eiramise võimalikud tagajärjed. ▶ Meetmed ja ettevaatusabinõud ohu vältimiseks.
--	---





Alljärgnevas näiteks on näidatud hoiatust, millega hoiatatakse liikuvatest osadest tingitud elektrilöögiuhtude eest. Nimetatud on meetet ohu vältimiseks.

	<div style="background-color: red; color: white; padding: 2px; display: inline-block;">⚠ OHT</div> Liikuvatest osadest tingitud elektrilöögi oht! Elektrilöögist tingitud surm ▶ Enne remonditöödega alustamist ühendage seadmed elektrivõrgust lahti vähemalt 60 sekundit varem.
---	--

1.2.4 Üldised sümbolid

Selles dokumendis kasutatakse alljärgnevaid üldisi sümboleid.

Üld. sümbol	Tähendus
	Erinõuande tunnus (tekst ja/või graafik)
	Lihtsa nõuande tunnus (ainult tekst)
	Videojuhendi lingi tunnus

Üld. sümbol	Tähendus
	Vajalike tööriistade tunnus
	Vajalike eeltingimuste tunnus
	Seisukorra tunnus (kui..., siis...)
	Tulemuse tunnus
[Start]	Klahvi või nupu tunnus
[00123456]	Materjalinumbriga tunnus
Olek	Kuvatava teksti/akna tunnus (seadme ekraanil)

Tabel 3: Üldised sümbolid

2.1 Üldised ohutusjuhised

2.1.1 Kõik kodumasinad

Liikuvatest osadest tingitud elektrilöögi oht!

- Elektriliste osade remondil tehtud vead võivad põhjustada elektrilööki!
- Lahutage seade vooluvõrgust vähemalt 60 sekundit enne tööle hakkamist.
- Pärast remonti peab olema tehtud ohutuskatse vastavalt standardile VDE 0701 või riiklikele määrustele.

Teravatest servadest tingitud vigastusoht!

- Kandke kaitsekindaid.

Rasketest ja liikuvatest osadest tingitud muljumisoht remondi-, puhastustööde, tõrkeotsingu ja hoolduse käigus

- Kandke turvakingi.
- Kinnitage rasked osad allakukkumise vastu.
- Ärge toppige kehaosi liikuvate osade vahele.

Oht seadme ohutusele/talitlusele!

- Kasutage ainult originaalvaruosasid.

Elektrostaatiliselt tundlike osade (ESD) kahjustamise oht!

- Ärge puudutage moduleid, kaasa arvatud ühendusi ega transportöörlinte.

Tööriistad ja abinõud

Määramine	Üksikasjad	Kujutised
Tähtotsik TX20 [00340865]	6,3 mm (1/4 tolli)	
Eritööriist [00342180]		

4.1 Uksetihendi vahetamine

Nõue:

- ✓ Uks on lahti.

4.1.1 Uksetihendi eemaldamine

1. Vabastage uksetihend soonest paremast ja vasakust nurgast.



2. Tõmmake uksetihend soonest välja.



- ➡ Uksetihend on eemaldatud.

4.1.2 Uksetihendi paigaldamine



Uue uksetihendi paksus võib veidi erineda vana tihendi paksusest. See ei mõjuta ukse sulgemist ja pikaajalist tööd.

Kui teie seadmel on reguleeritavad hinged või hingekinnitused, saate sulgemismehhanismi hiljem sobivaks sättida.

Väikesed augud uksetihendis on vajalikud õhutuseks. Need ei ole tootmisvead.

1. Kontrollige, kas tihendi soon on terve.

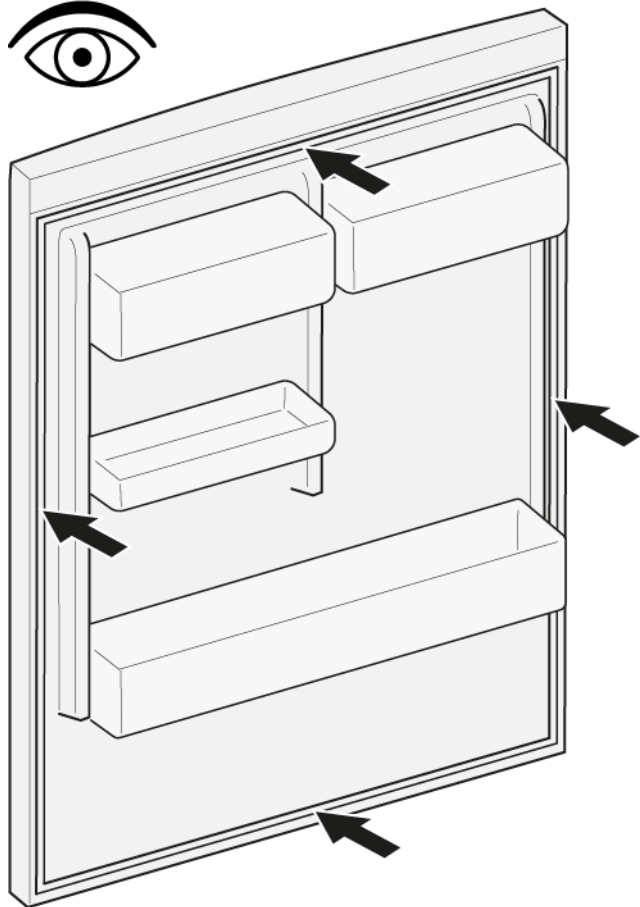

4. Lükake tihendi otsad soone üla- ja alanurka.

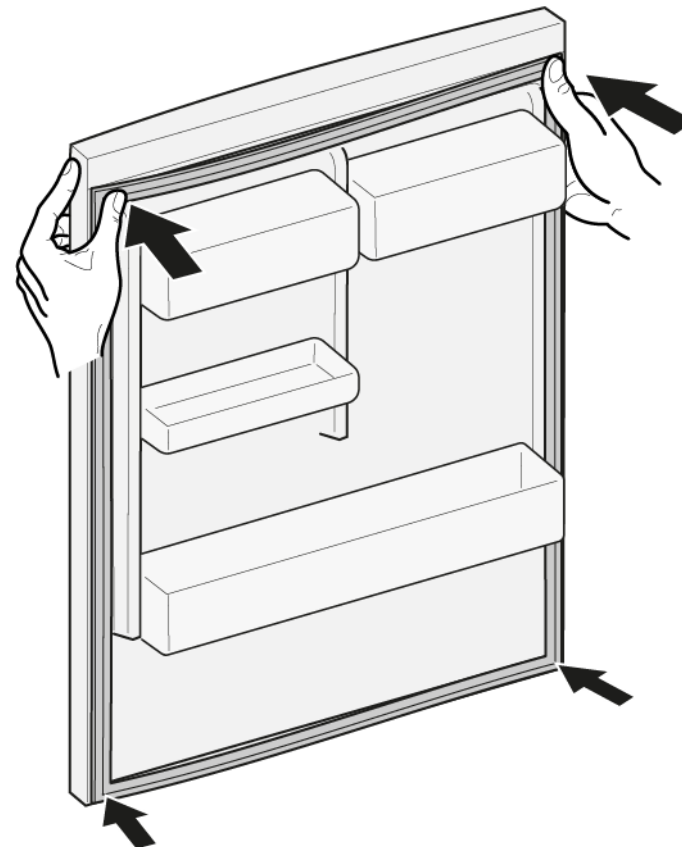

2.  Kui tihendi soon on kahjustatud,
- pöörduge klienditeeninduse poole.

3.  Uksetihendi kerge kõverdumine on normaalne ega mõjuta selle toimivust. Soovitav on uksetihend enne seadmesse paigaldamist sirgu tõmmata.

Soojendage uksetihendit fööni või sooja veega ja vormige seda käsitsi.

5. Vajutage terve tihend jupphaaval soonde.

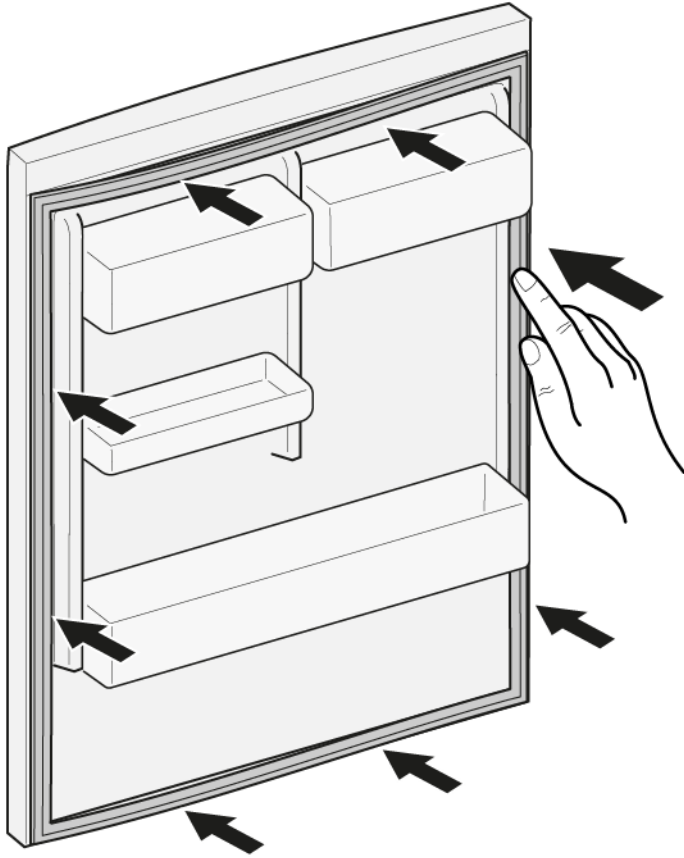

➡ Uksetihend on paigaldatud.

4.2 Käepideme vahetamine

Eritööriistad:

- ☞ Tähtsük TX20 6,3 mm (1/4 tolli) [00340865]
- ☞ Lapik kruvikeeraja Tera 10 mm × 1,6 mm × 200 mm

Nõue:

- ✔ Seade on toitest lahutatud.
- ✔ Uks on lahti.

4.2.1 Käepideme eemaldamine

- ▶ 1. Eemaldage kaks kruvikatet (1).
- ▶ 2. Keerake lahti kaks kruvi (2).
- ▶ 3. Eemaldage käepide (3).

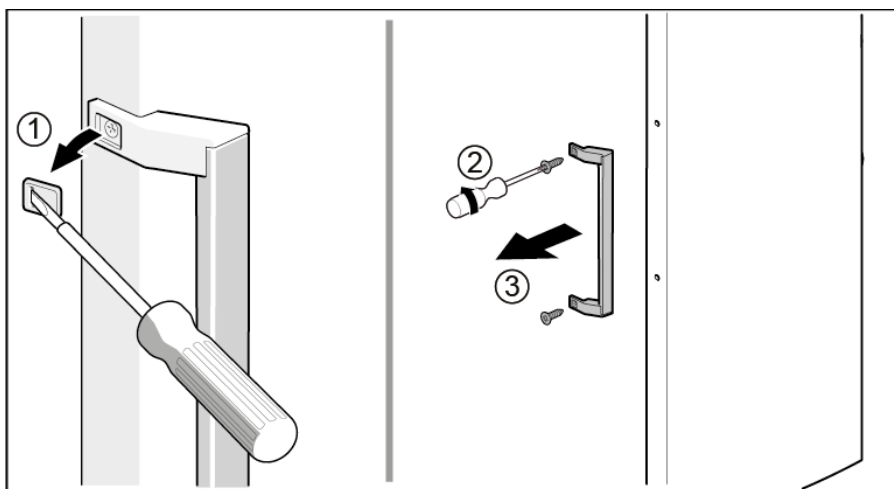

- ➔ Ukse käepide on eemaldatud.



Teise ukse käepidet saab eemaldada samamoodi.

4.2.2 Käepideme paigaldamine

- ▶ Paigaldage vastupidises järjekorras.

4.3 Ülemise uksehinge vahetamine

Eritööriistad:

Tähtotsik TX20

6,3 mm (1/4 tolli)

[00340865]

	<p style="text-align: center;">⚠ HOIATUS</p> <p>Masked, kogukad seadmed! Selja- ja lihasevigastused</p> <ul style="list-style-type: none"> ▶ Seadme ust tohivad eemaldada vaid vastava väljaõppe saanud spetsialistid. ▶ Seadme liigutamiseks on vaja kaht inimest. ▶ Kasutage vaid sobivaid tööriistu ja varustust.
	<p style="text-align: center;">⚠ ETTEVAATUST!</p> <p>Teravad servad! Lõikehaavad</p> <ul style="list-style-type: none"> ▶ Kandke kaitsekindaid.
	<p style="text-align: center;">⚠ HOIATUS</p> <p>Viltuses asendis seadmete libisemisoht! Luumurrud/muljumised</p> <ul style="list-style-type: none"> ▶ Kindlustage seadmed libisemise vastu.
	<p style="text-align: center;">⚠ ETTEVAATUST!</p> <p>Lahtikeeratud poltidest tingitud osade kukkumisoht! Kukkuvatest osadest tingitud vigastused.</p> <ul style="list-style-type: none"> ▶ Kinnitage osa allakukkumise vastu.
	<p style="text-align: center;">TÄHELEPANU!</p> <p>Lahtikeeratud poltidest tingitud osade kukkumisoht! Seadme teiste osade kahjustused või klientide vara kahjustused.</p> <ul style="list-style-type: none"> ▶ Kinnitage osa allakukkumise vastu.

Nõue:

- ✔ Seade on toitest lahutatud.
- ✔ Seadme sisearmatuur on eemaldatud.

4.3.1 Ülemise uksehinge eemaldamine

1. Libistage tugiosa aluse profiili alla.

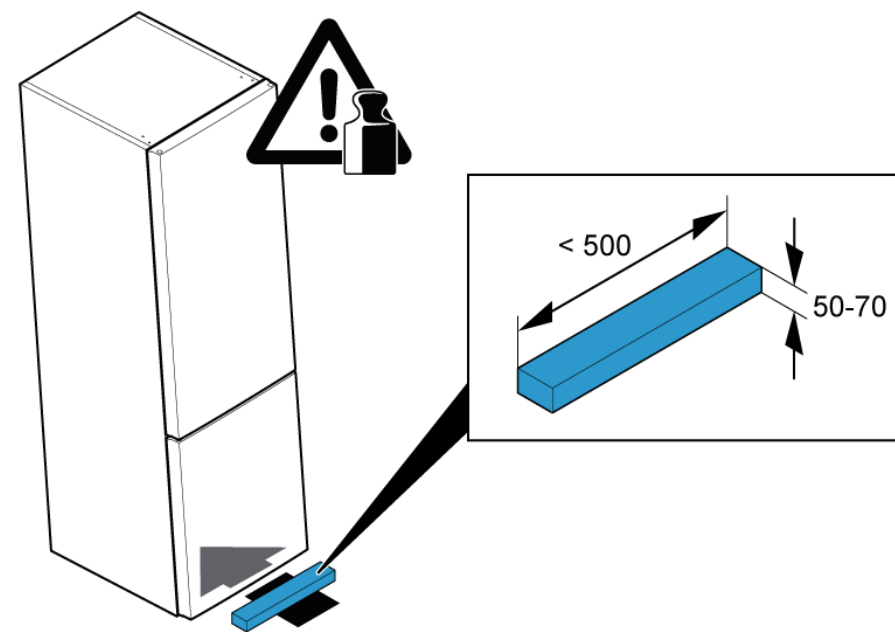

2. 1. Eemaldage ülemise hinge kate (1).
2. Keerake lahti kaks kruvi (2).
3. Eemaldage ülemine hing (3).

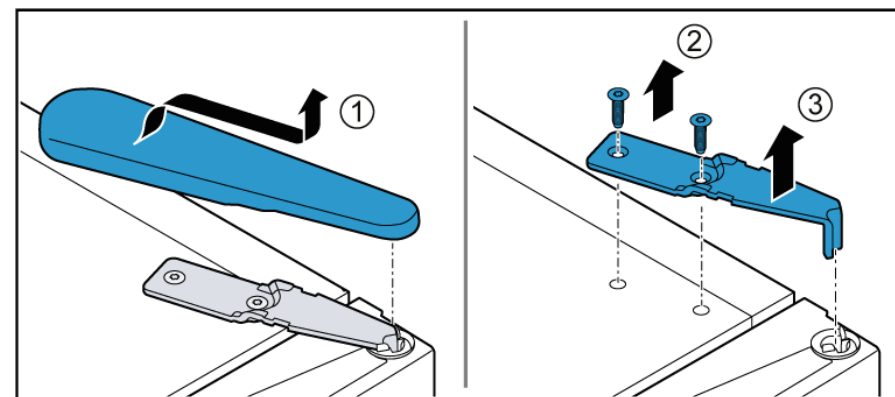

3. Eemaldage ülemine uks.

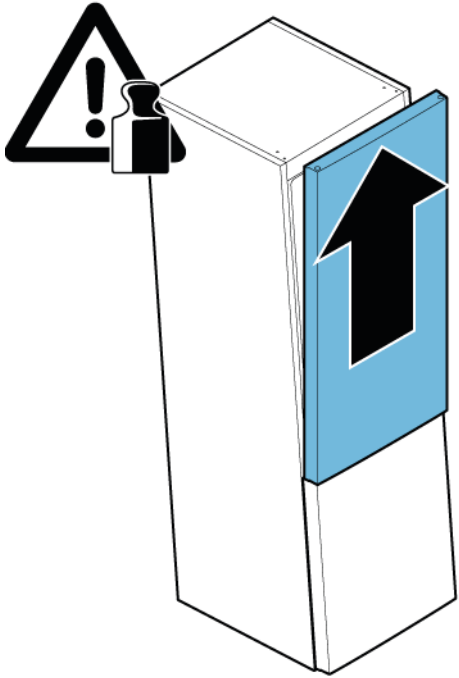

 Ülemine hing on eemaldatud.

4.3.2 Ülemise uksehinge paigaldamine

▶ Paigaldage vastupidises järjekorras.

4.4 Ülemise uksehingega vahetamine (uks koos kuvaga)

Eritööriistad:

Tähtotsik TX20 6,3 mm (1/4 tolli) [00340865]

	<p style="text-align: center;">HOIATUS</p> <p>Masked, kogukad seadmed! Selja- ja lihasevigastused</p> <ul style="list-style-type: none"> ▶ Seadme ust tohivad eemaldada vaid vastava väljaõppe saanud spetsialistid. ▶ Seadme liigutamiseks on vaja kaht inimest. ▶ Kasutage vaid sobivaid tööriistu ja varustust.
	<p style="text-align: center;">ETTEVAATUST!</p> <p>Teravad servad! Lõikehaavad</p> <ul style="list-style-type: none"> ▶ Kandke kaitsekindaid.
	<p style="text-align: center;">HOIATUS</p> <p>Viltuses asendis seadmete libisemisoht! Luumurrud/muljumised</p> <ul style="list-style-type: none"> ▶ Kindlustage seadmed libisemise vastu.
	<p style="text-align: center;">ETTEVAATUST!</p> <p>Lahtikeeratud poltidest tingitud osade kukkumisoht! Kukkuvatest osadest tingitud vigastused.</p> <ul style="list-style-type: none"> ▶ Kinnitage osa allakukkumise vastu.
	<p style="text-align: center;">TÄHELEPANU!</p> <p>Lahtikeeratud poltidest tingitud osade kukkumisoht! Seadme teiste osade kahjustused või klientide vara kahjustused.</p> <ul style="list-style-type: none"> ▶ Kinnitage osa allakukkumise vastu.

	<p style="text-align: center;">OHT</p> <p>Liikuvatest osadest tingitud elektrilöögi oht! Kui remonditööd on valesti tehtud, esineb elektrilöögist tingitud eluoht.</p> <ul style="list-style-type: none"> ▶ Elektrilisi osasid peavad parandama kvalifitseeritud elektrikud. ▶ Pärast remonti peab olema tehtud ohutuskatse vastavalt standardile VDE 0701 või riiklikele määrustele.
---	---

	<p style="text-align: center;">OHT</p> <p>Liikuvatest osadest tingitud elektrilöögi oht! Elektrilöögist tingitud surm</p> <ul style="list-style-type: none"> ▶ Enne remonditöödega alustamist ühendage seadmed elektrivõrgust lahti vähemalt 60 sekundit varem.
---	--

Nõue:

- ✓ Seade on toitest lahutatud.
- ✓ Seadme sisearmatuur on eemaldatud.

4.4.1 Ülemise uksehingega eemaldamine

1. Libistage tugiosa aluse profilli alla.

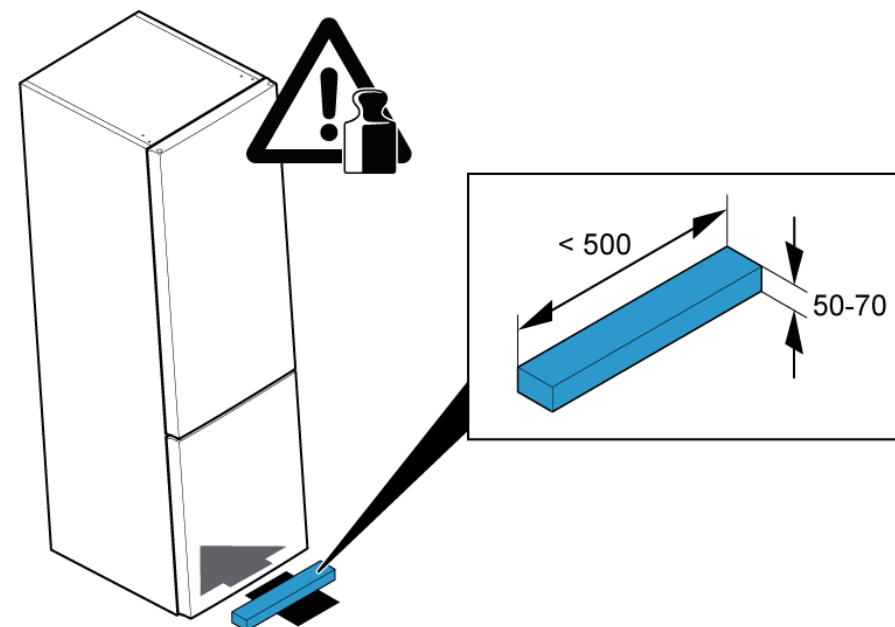

Remont

2. 1. Eemaldage ülemise hinge kate (1).
2. Lahutage elektriühendus (2).
3. Keerake lahti maaühenduse kruvi (3).

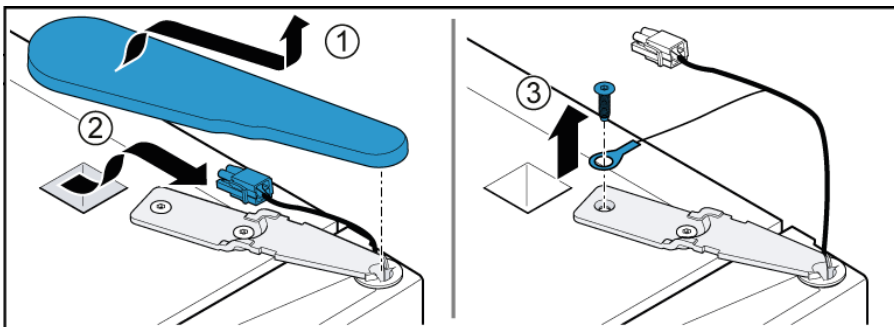

3. 1. Keerake kruvi (1) lahti.
2. Eemaldage ülemine hing (2).

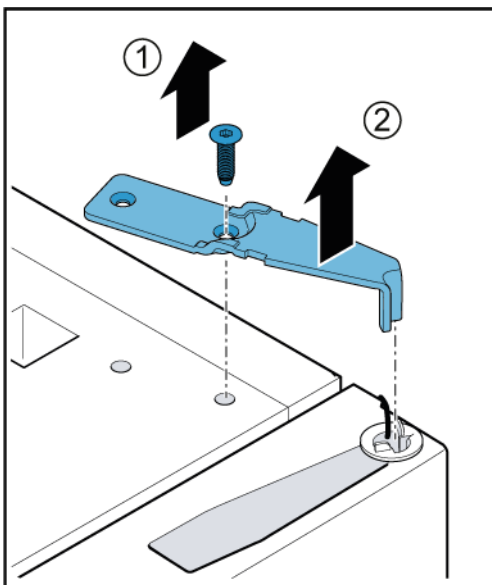

4. Eemaldage ülemine uks.

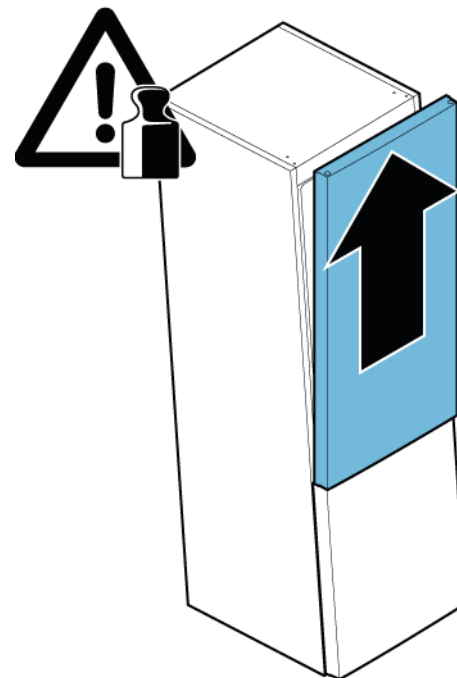

➔ Ülemine hing on eemaldatud.

4.4.2 Ülemise uksehinge paigaldamine

- ▶ Paigaldage vastupidises järjekorras.

4.5 Keskmise uksehinge vahetamine

Eritööriistad:

Tähtotsik TX20

6,3 mm (1/4 tolli)

[00340865]

	<p style="text-align: center;">⚠ HOIATUS</p> <p>Masked, kogukad seadmed! Selja- ja lihasevigastused</p> <ul style="list-style-type: none"> ▶ Seadme ust tohivad eemaldada vaid vastava väljaõppe saanud spetsialistid. ▶ Seadme liigutamiseks on vaja kaht inimest. ▶ Kasutage vaid sobivaid tööriistu ja varustust.
	<p style="text-align: center;">⚠ ETTEVAATUST!</p> <p>Teravad servad! Lõikehaavad</p> <ul style="list-style-type: none"> ▶ Kandke kaitsekindaid.
	<p style="text-align: center;">⚠ HOIATUS</p> <p>Viltuses asendis seadmete libisemisoht! Luumurrud/muljumised</p> <ul style="list-style-type: none"> ▶ Kindlustage seadmed libisemise vastu.
	<p style="text-align: center;">⚠ ETTEVAATUST!</p> <p>Lahtikeeratud poltidest tingitud osade kukkumisoht! Kukkuvatest osadest tingitud vigastused.</p> <ul style="list-style-type: none"> ▶ Kinnitage osa allakukkumise vastu.
	<p style="text-align: center;">TÄHELEPANU!</p> <p>Lahtikeeratud poltidest tingitud osade kukkumisoht! Seadme teiste osade kahjustused või klientide vara kahjustused.</p> <ul style="list-style-type: none"> ▶ Kinnitage osa allakukkumise vastu.

Nõue:

- ✔ Seade on toitest lahutatud.
- ✔ Seadme sisearmatuur on eemaldatud.
- ✔ Ülemine uksehing on eemaldatud.
- ✔ Ülemine uks on eemaldatud.

4.5.1 Keskmise uksehinge eemaldamine

1. Keerake lahti kaks kruvi (1).
2. Eemaldage keskmine hing (2).

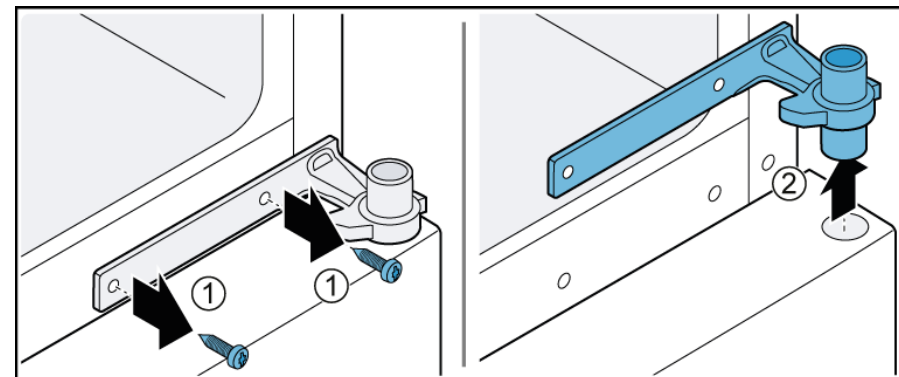

2. Eemaldage alumine uks.

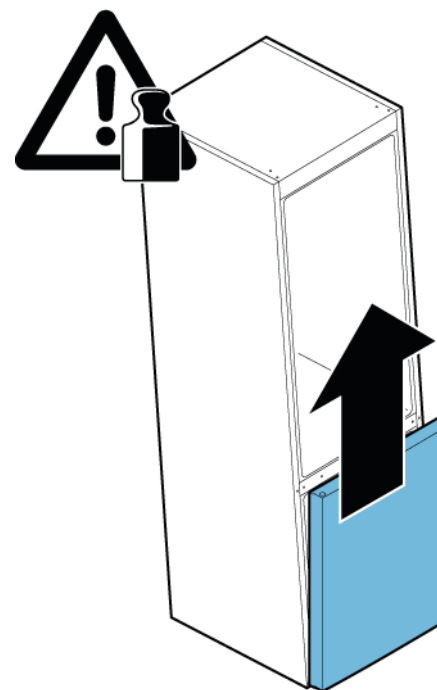

- ➡ Keskmine hing on eemaldatud.

4.5.2 Keskmise uksehinge paigaldamine

- ▶ Paigaldage vastupidises järjekorras.

4.6 Alumise uksehinge vahetamine

Eritööriistad:

Tähtotsik TX20

6,3 mm (1/4 tolli)

[00340865]

	<p style="text-align: center;">⚠ HOIATUS</p> <p>Masked, kogukad seadmed! Selja- ja lihasevigastused</p> <ul style="list-style-type: none"> ▶ Seadme ust tohivad eemaldada vaid vastava väljaõppe saanud spetsialistid. ▶ Seadme liigutamiseks on vaja kaht inimest. ▶ Kasutage vaid sobivaid tööriistu ja varustust.
	<p style="text-align: center;">⚠ ETTEVAATUST!</p> <p>Teravad servad! Lõikehaavad</p> <ul style="list-style-type: none"> ▶ Kandke kaitsekindaid.
	<p style="text-align: center;">⚠ HOIATUS</p> <p>Viltuses asendis seadmete libisemisoht! Luumurrud/muljumised</p> <ul style="list-style-type: none"> ▶ Kindlustage seadmed libisemise vastu.
	<p style="text-align: center;">⚠ ETTEVAATUST!</p> <p>Lahtikeeratud poltidest tingitud osade kukkumisoht! Kukkuvatest osadest tingitud vigastused.</p> <ul style="list-style-type: none"> ▶ Kinnitage osa allakukkumise vastu.
	<p style="text-align: center;">TÄHELEPANU!</p> <p>Lahtikeeratud poltidest tingitud osade kukkumisoht! Seadme teiste osade kahjustused või klientide vara kahjustused.</p> <ul style="list-style-type: none"> ▶ Kinnitage osa allakukkumise vastu.

Nõue:

- ✔ Seade on toitest lahutatud.
- ✔ Seadme sisearmatuur on eemaldatud.
- ✔ Ülemine hing on eemaldatud.
- ✔ Keskmine hing on eemaldatud.

4.6.1 Alumise uksehinge eemaldamine

- ▶ 1. Keerake lahti kaks kruvi (1).
- ▶ 2. Eemaldage alumine hing (2).

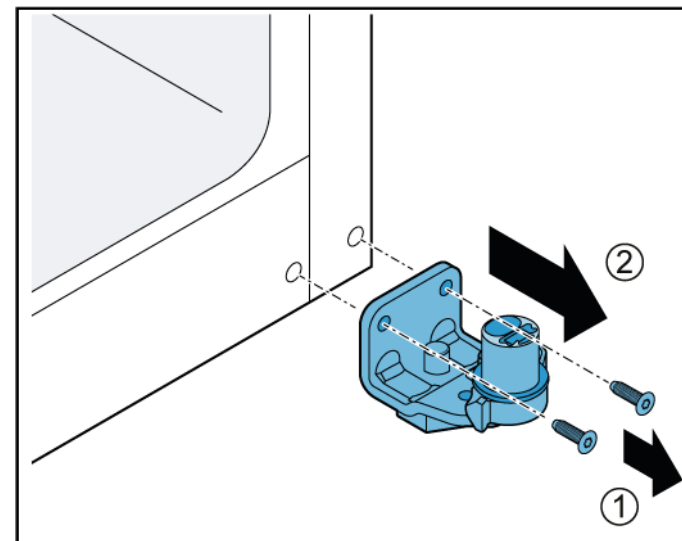

➡ Alumine uksehing on eemaldatud.

4.6.2 Alumise uksehinge paigaldamine

- ▶ Paigaldage vastupidises järjekorras.

4.7 Riiuli vahetamine

Nõue:

- ✓ Uks on lahti.

4.7.1 Riiuli eemaldamine

- ▶ 1. Tõstke riiul tagaosast üles (1).
- ▶ 2. Vabastage riiul (2).

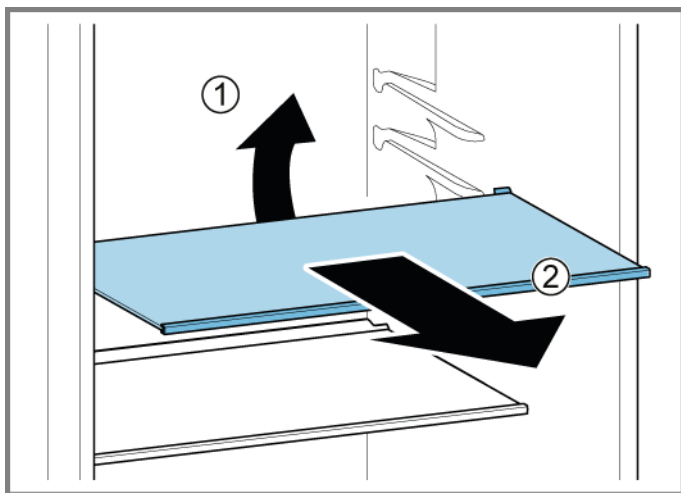

➡ Riiul on eemaldatud.

4.7.2 Riiuli paigaldamine

- ▶ Paigaldage vastupidises järjekorras.

4.8 Pudelialuse vahetamine

Nõue:

- ✓ Uks on lahti.

4.8.1 Pudelialuse eemaldamine

- ▶ Tõmmake pudelialus välja.

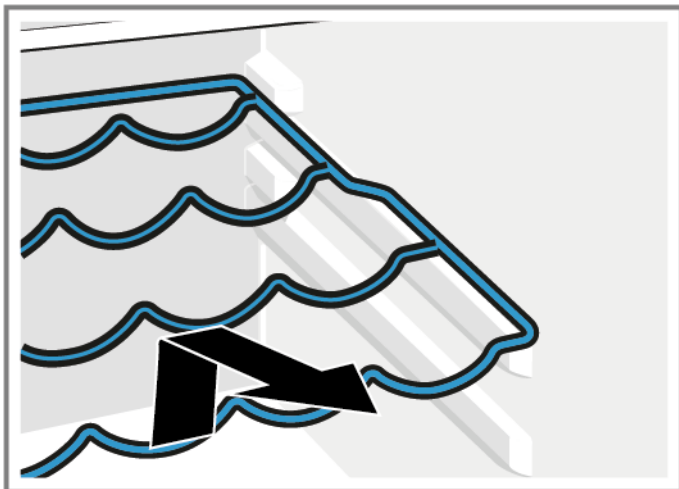

- ➡ Pudelialus on eemaldatud.

4.8.2 Pudelialuse paigaldamine

- ▶ Paigaldage vastupidises järjekorras.

4.9 Ukseraami vahetamine

Nõue:

- ✓ Uks on lahti.

4.9.1 Ukseraami eemaldamine

- ▶ Tõstke ukseraam üles.

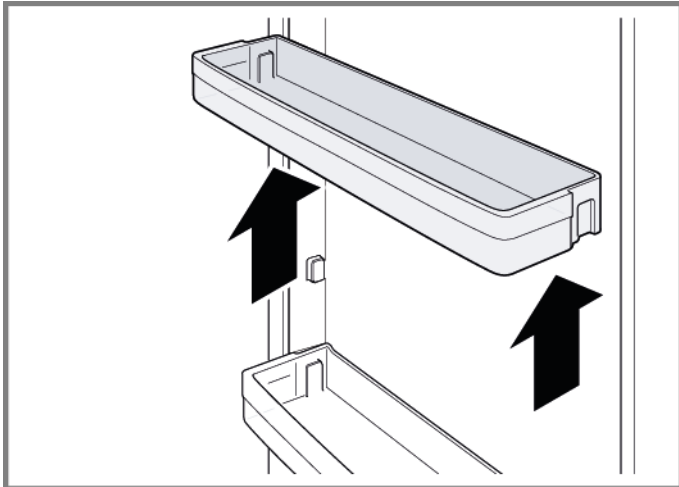

- ➔ Ukseraam on eemaldatud.

4.9.2 Ukseraami paigaldamine

- ▶ Paigaldage vastupidises järjekorras.

4.10 Hoiumahuti vahetamine

Nõue:

- ✓ Uks on lahti.

4.10.1 Hoiumahuti eemaldamine

1. Tõmmake hoiumahuti nii kaugele välja, kui see ulatub.
2. 1. Tõstke hoiumahutit esiosast (1).
2. Eemaldage mahuti (2).

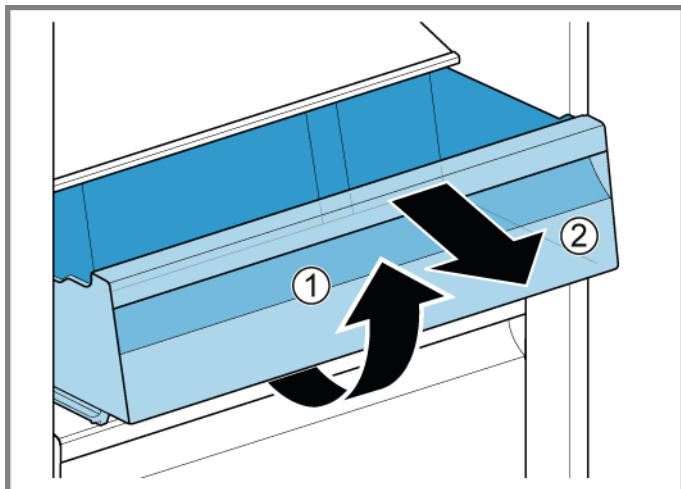

- ➔ Hoiumahuti on eemaldatud.

4.10.2 Hoiumahuti paigaldamine

- ▶ Paigaldage vastupidises järjekorras.

4.11 Puu- ja köögiviljamahuti vahetamine

Nõue:

- ✓ Uks on lahti.

4.11.1 Puu- ja köögiviljamahuti eemaldamine

1. Tõmmake puu- ja köögiviljade mahuti nii kaugele välja, kui see ulatub.
2. 1. Tõstke puu- ja köögiviljamahutit esiosast (1).
2. Eemaldage mahuti (2).

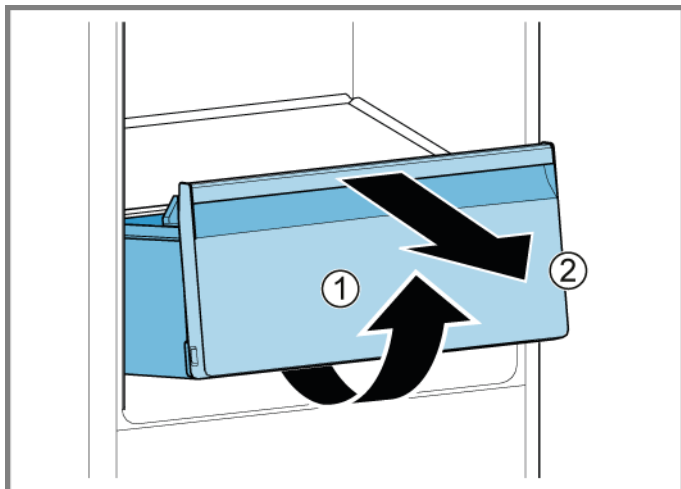

- ➔ Puu- ja köögiviljamahuti on eemaldatud.

4.11.2 Puu- ja köögiviljamahuti paigaldamine

- ▶ Paigaldage vastupidises järjekorras.

4.12 Puu- ja köögiviljamahuti kohal oleva riuli vahetamine

Nõue:

- ✓ Uks on lahti.
- ✓ [Puu- ja köögiviljamahuti on eemaldatud. → 200](#)

4.12.1 Puu- ja köögiviljamahuti kohal oleva riuli eemaldamine

1. Suruge tihendusraami üles ja tõmmake väljapoole.

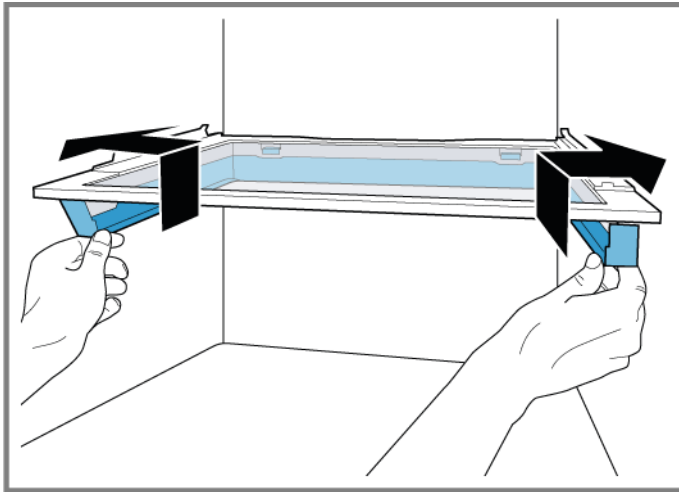

➡ Küljehaagid vabastatakse.

2. Tõstke tihendusraami ja libistage seda tagasi.

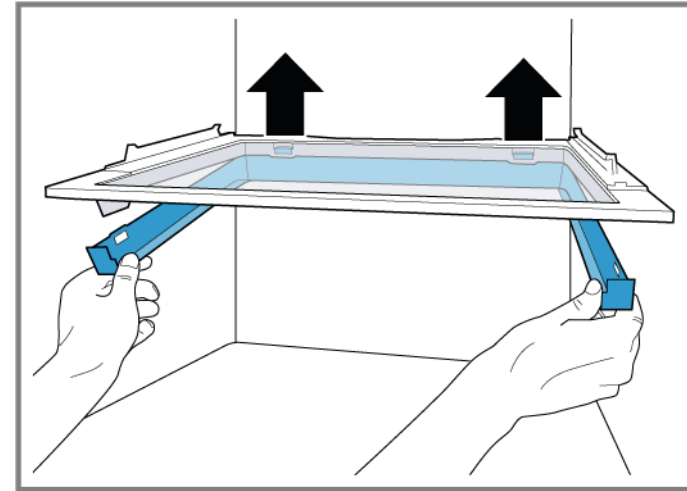

➡ Tagumised haagid vabastatakse.

3. Eemaldage tihendusraam.
4. Tõstke puu- ja köögiviljamahuti kohal olevat riulit ning pöörake see küljele keerates välja.

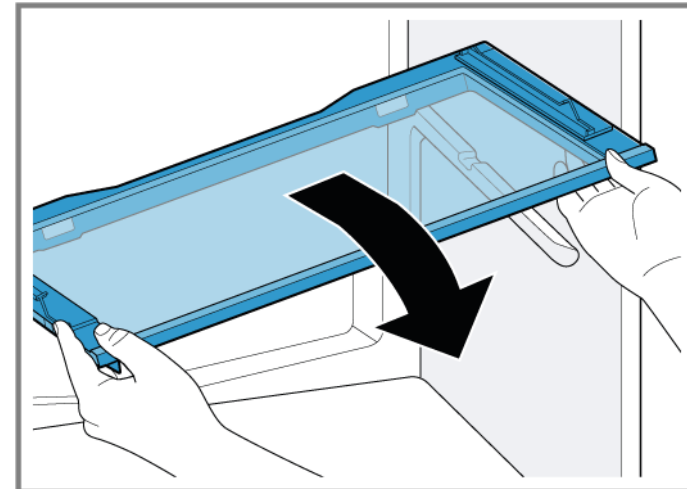

➡ Puu- ja köögiviljamahuti kohal olev riul on eemaldatud.

4.12.2 Puu- ja köögiviljamahuti kohal oleva riuli paigaldamine

- ▶ Paigaldage vastupidises järjekorras.

4.13 Külmutatud toidu mahuti vahetamine

Nõue:

- ✔ Uks on lahti.

4.13.1 Külmutatud toidu mahuti eemaldamine

- ▶ 1. Tõmmake külmutatud toidu mahuti täielikult välja (1).
- ▶ 2. Eemaldage toidumahuti (2).

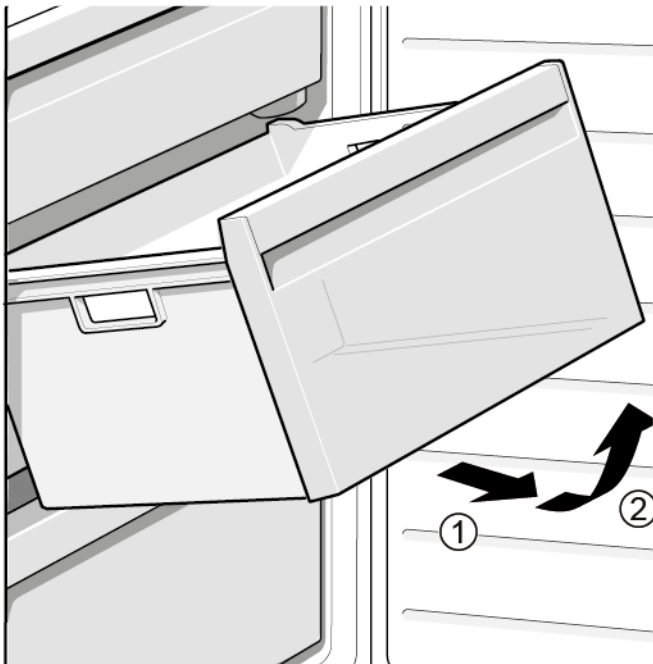

- ➡ Külmutatud toidu mahuti on eemaldatud.

4.13.2 Külmutatud toidu mahuti paigaldamine

- ▶ Paigaldage vastupidises järjekorras.

4.14 Ülemise LED-lambi vahetamine

Eritööriistad:

Eritööriist

[00342180]



Teie seadmel on LED-tuli, mis ei vaja hooldust.
Seda tuld tohib parandada ainult klienditeenindus või volitatud tehnik!



OHT

Liikuvatest osadest tingitud elektrilöögi oht!

Kui remonditööd on valesti tehtud, esineb elektrilöögist tingitud eluohu.

- ▶ Elektrilisi osasid peavad parandama kvalifitseeritud elektrikud.
- ▶ Pärast remonti peab olema tehtud ohutuskatse vastavalt standardile VDE 0701 või riiklikele määrustele.



OHT

Liikuvatest osadest tingitud elektrilöögi oht!

Elektrilöögist tingitud surm

- ▶ Enne remonditöödega alustamist ühendage seadmed elektrivõrgust lahti vähemalt 60 sekundit varem.



ETTEVAATUST!

Teravad servad!

Lõikehaavad

- ▶ Kandke kaitsekindaid.

Nõue:

- ✔ Seade on toitest lahutatud.
- ✔ Uks on lahti.

4.14.1 Ülemise LED-lambi eemaldamine

1. Libistage lambi haakide (1) vabastamiseks demonteerimistöõriist ülemise LED-lambi ja külmiku sahtli sisekülje vahele.
2. Eemaldage ülemine LED-lamp (2).

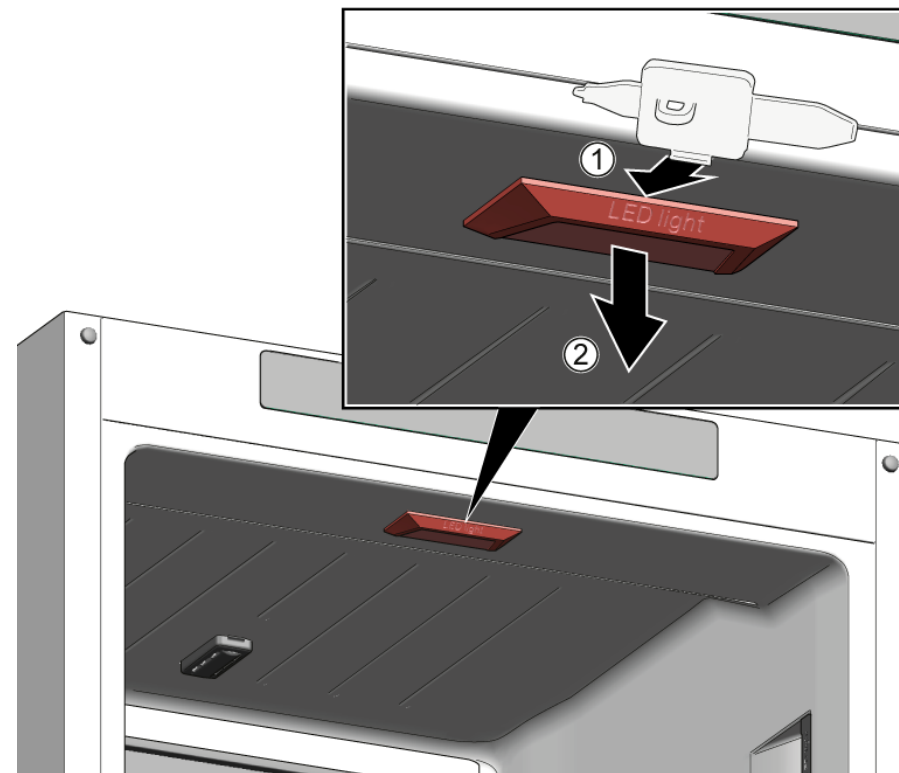

2. Lahutage ülemise LED-lambi elektrühendus.
- ➔ Ülemine LED-lamp on eemaldatud.

4.14.2 Ülemise LED-lambi paigaldamine

- ▶ Paigaldage vastupidises järjekorras.

4.15 Külgmise LED-lambi vahetamine

Eritööriistad:

Eritööriist [00342180]

i Teie seadmel on LED-tuli, mis ei vaja hooldust. Seda tuld tohib parandada ainult klienditeenindus või volitatud tehnik!

! OHT
Liikuvatest osadest tingitud elektrilöögi oht!
 Kui remonditööd on valesti tehtud, esineb elektrilöögist tingitud eluoht.
 ▶ Elektrilisi osad peavad parandama kvalifitseeritud elektrikud.
 ▶ Pärast remonti peab olema tehtud ohutuskatse vastavalt standardile VDE 0701 või riiklikele määrustele.

! OHT
Liikuvatest osadest tingitud elektrilöögi oht!
 Elektrilöögist tingitud surm
 ▶ Enne remonditöödega alustamist ühendage seadmed elektrivõrgust lahti vähemalt 60 sekundit varem.

! ETTEVAATUST!
Teravad servad!
 Lõikehaavad
 ▶ Kandke kaitsekindaid.

! TÄHELEPANU!
Elektrostaatiliselt tundlike osade (ESD) kahjustamise oht!
 Osade kahjustamine
 ▶ Enne ESD-de puudutamist veenduge, et kasutaksite antistaatilisest kaitsestüsteemi (maandusega ühendatava pistikuga käepael).
 ▶ Ärge puudutage moodulite ühendusi ega juhtivaid kontuure.
 ▶ Transportige ESD-sid ainult juhtivate materjalide sees või originaalpakendis.
 ▶ Hoidke ESD-d elektrostaatiliselt laetavatest materjalidest (nt plast) eemal.

Nõue:

- ✓ Seade on toitest lahutatud.
- ✓ Uks on lahti.

✓ RC sisearmatuur on eemaldatud.

4.15.1 Külgmise LED-lambi eemaldamine

1. 1. Libistage demonteerimistöriist haagi vabastamiseks lambi difuusori ja kor-puse vahele (1).
2. 2. Võtke lambi difuuser välja (2).
3. 3. Vabastage järgmised difuusori kinnitushaagid samal viisil.

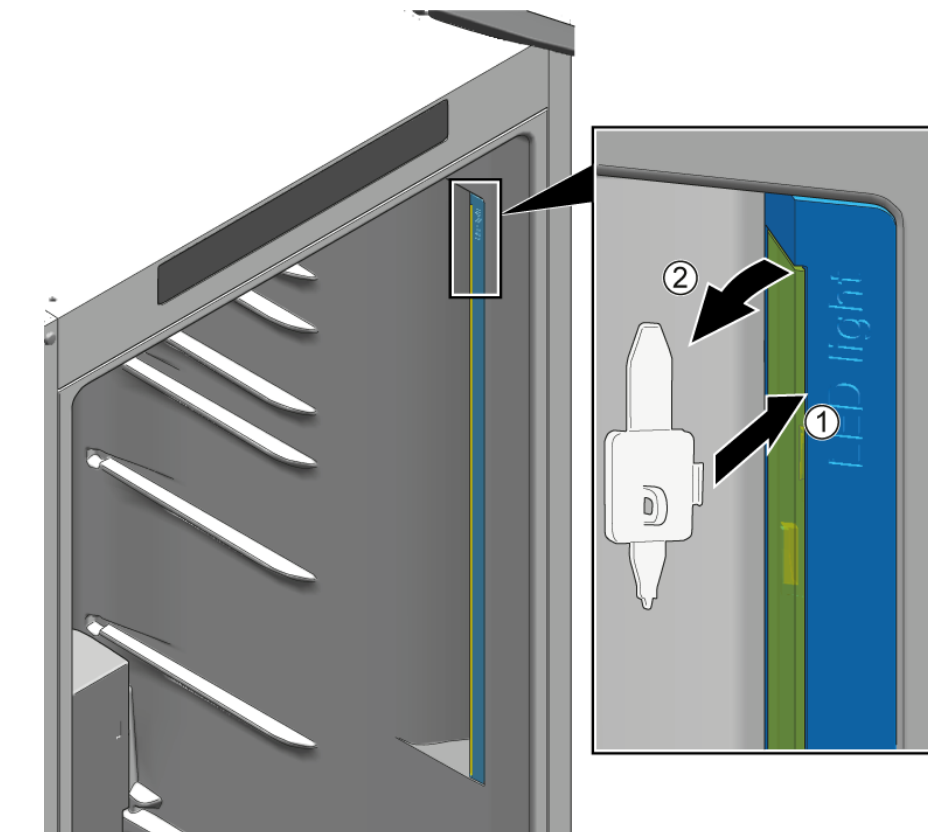

➔ Lambi difuuser on eemaldatud.

1. Vajutage kinnitushaaki, et seda vabastada (1).
2. Liigutage LED-moodulit umbes 1 cm võrra üles, et see pistikupesast lahutada (2).
3. Eemaldage LED-moodul (3).

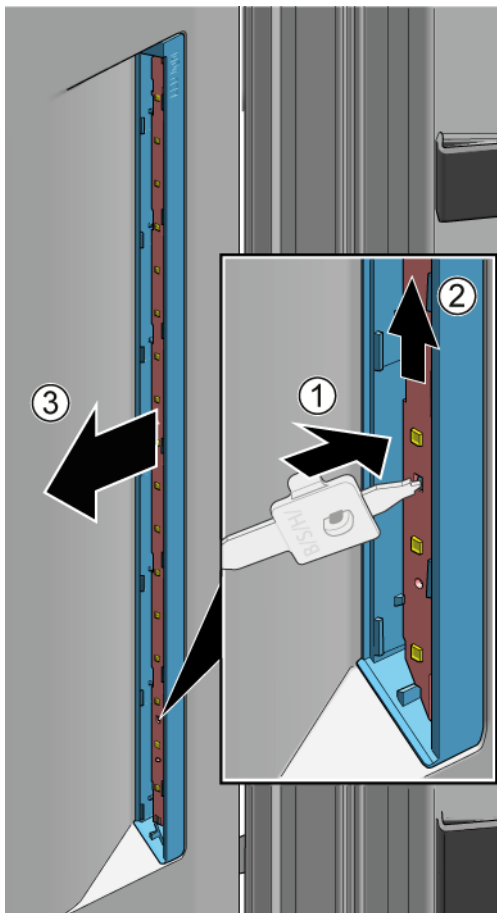

➔ Külgmise LED-lamp on eemaldatud.

4.15.2 Külgmise LED-lambi paigaldamine



Kuna lambi difuusori haagid võivad eemaldamisel kergesti puruneda, sisaldab külgmise LED-lambi varuosa LED-moodulit ja lambi difuusorit.

1. Libistage demonteerimistööriist haagi vabastamiseks lambi difuusori ja kor-puse vahele (1).
2. Võtke lambi difuusor välja (2).
3. Vabastage järgmised difuusori kinnitushaagid samal viisil.

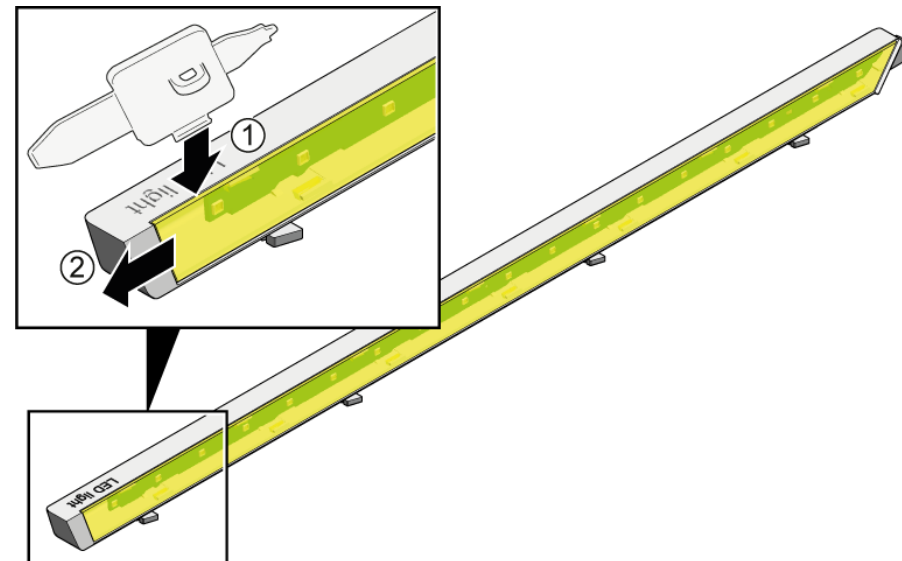

Remont

1. Vajutage kinnitushaaki, et seda vabastada (1).
2. Libistage LED-moodul ülespoole korpusest välja.
3. Visake ära LED-mooduli korpus, mida kasutati varuosa kaitsmiseks transportimisel (3).

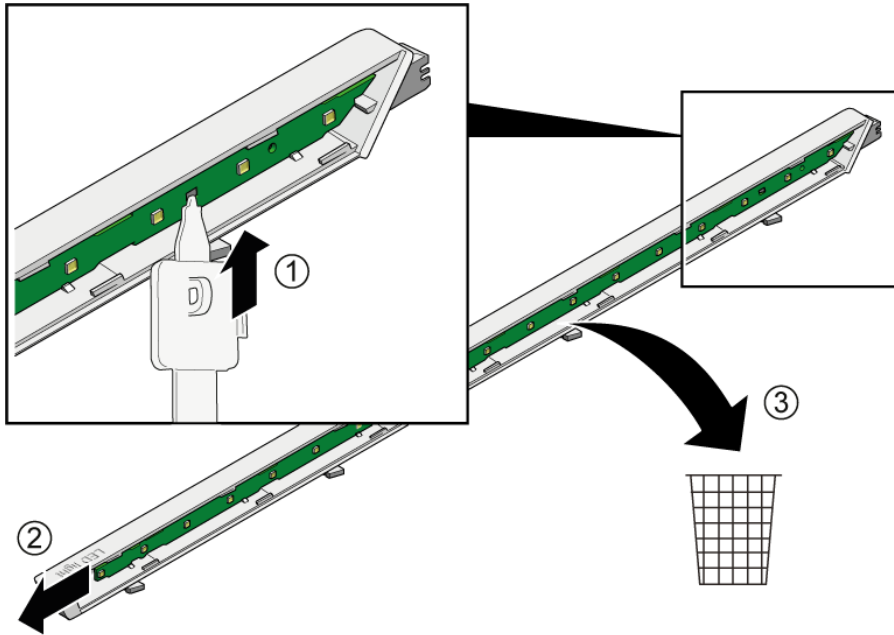

3. Paigaldage LED-moodul ja lambi difuuser eemaldamisele vastupidises järjekorras.

4.16 Külmiku LED-lambi vahetamine

Eritööriistad:

Eritööriist [00342180]

i Teie seadmel on LED-tuli, mis ei vaja hooldust. Seda tuld tohib parandada ainult klienditeenindus või volitatud tehnik!

! **OHT**
Liikuvatest osadest tingitud elektrilöögi oht!
 Kui remonditööd on valesti tehtud, esineb elektrilöögist tingitud eluoht.
 ▶ Elektrilisi osadid peavad parandama kvalifitseeritud elektrikud.
 ▶ Pärast remonti peab olema tehtud ohutuskatse vastavalt standardile VDE 0701 või riiklikele määrustele.

! **OHT**
Liikuvatest osadest tingitud elektrilöögi oht!
 Elektrilöögist tingitud surm
 ▶ Enne remonditöödega alustamist ühendage seadmed elektrivõrgust lahti vähemalt 60 sekundit varem.

! **ETTEVAATUST!**
Teravad servad!
 Lõikehaavad
 ▶ Kandke kaitsekindaid.

Nõue:

- ✔ Seade on toitest lahutatud.
- ✔ Uks on lahti.

4.16.1 Külmiku LED-lambi eemaldamine

- ▶ 1. Libistage demonteerimistöööriist vahe tekitamiseks (1) lambi kõrvale lambi ja korpuse vahele.
- ▶ 2. Libistage demonteerimistöööriist lambi fikseerimishaagi teisele küljele ja keerake seda edasi (2).
- ▶ 3. Eemaldage külmiku LED-lamp (3).

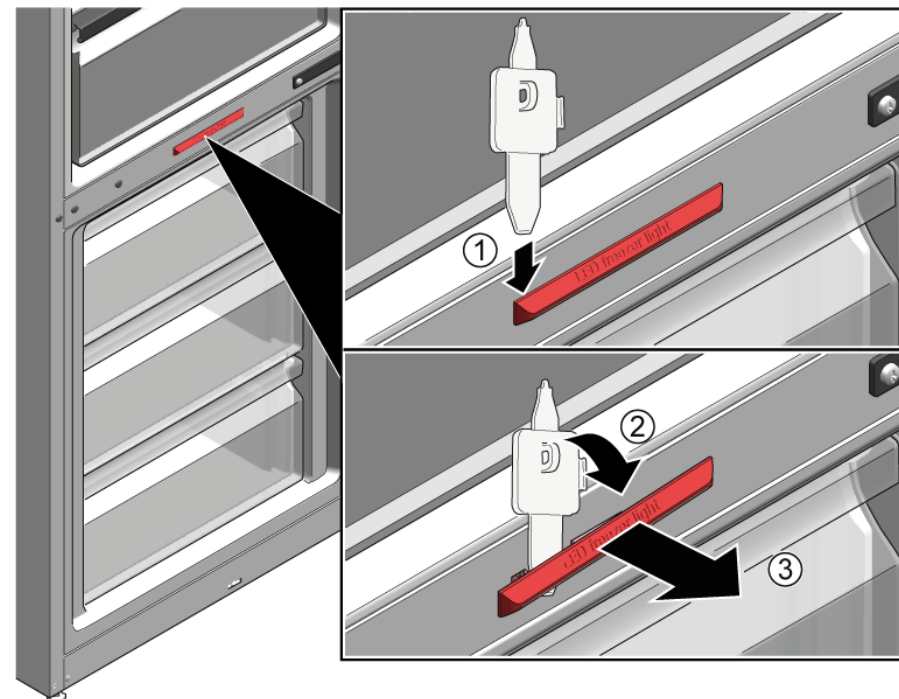





- ➡ Külmiku LED-lamp on lahutatud.
- ➡ Külmiku LED-lamp on eemaldatud.

4.16.2 Külmiku LED-lambi paigaldamine

- ▶ Paigaldage vastupidises järjekorras.

Korjausvinkit - Jääkaappipakastin

 Tämä asiakirja	210
1.1 Tärkeitä tietoja.....	210
1.1.1 Tarkoitus	210
1.2 Symboleiden merkitys.....	210
1.2.1 Vaaratasot.....	210
1.2.2 Varoitusmerkit.....	210
1.2.3 Varoitusten rakenne	211
1.2.4 Yleiset symbolit.....	211
 Turvallisuus	212
2.1 Yleiset turvallisuusohjeet.....	212
2.1.1 Kaikki kotitalouskoneet.....	212
 Työkalut ja apuvälineet	213
 Korjaus	214
4.1 Oven tiivisteen vaihtaminen.....	214
4.1.1 Oven tiivisteen poistaminen	214
4.1.2 Oven tiivisteen asennus	214
4.2 Ovenkahvan vaihtaminen.....	217
4.2.1 Ovenkahvan poistaminen	217
4.2.2 Ovenkahvan asennus.....	217
4.3 Oven yläsaranan vaihtaminen	218
4.3.1 Oven yläsaranan poistaminen.....	218
4.3.2 Oven yläsaranan asennus	219
4.4 Oven yläsaranan vaihtaminen (näytöllä varustettu ovi).....	220
4.4.1 Oven yläsaranan poistaminen.....	221
4.4.2 Oven yläsaranan asennus	222
4.5 Oven keskisaranan vaihtaminen.....	223
4.5.1 Oven keskisaranan poistaminen	223
4.5.2 Oven keskisaranan asennus.....	224
4.6 Oven alasaranan vaihtaminen	225
4.6.1 Oven alasaranan poistaminen.....	225
4.6.2 Oven alasaranan asennus.....	225
4.7 Hyllyn vaihtaminen	226
4.7.1 Hyllyn poistaminen	226
4.7.2 Hyllyn asennus	226

4.8 Pullohyllyn vaihtaminen	227
4.8.1 Pullohyllyn poistaminen	227
4.8.2 Pullohyllyn asennus	227
4.9 Ovihyllyn vaihtaminen	228
4.9.1 Ovihyllyn poistaminen	228
4.9.2 Ovihyllyn asennus	228
4.10 Säilytyslokero vaihtaminen	229
4.10.1 Säilytyslokero poistaminen	229
4.10.2 Säilytyslokero asennus	229
4.11 Hedelmä- ja vihanneslokero vaihtaminen.....	230
4.11.1 Hedelmä- ja vihanneslokero poistaminen	230
4.11.2 Hedelmä- ja vihanneslokero asennus	230
4.12 Hedelmä- ja vihanneslokero yläpuolella olevan hyllyn vaihtaminen.....	231
4.12.1 Hedelmä- ja vihanneslokero yläpuolella olevan hyllyn vaihtaminen ...	231
4.12.2 Hedelmä- ja vihanneslokero yläpuolella olevan hyllyn asennus	232
4.13 Pakastelokero vaihtaminen	233
4.13.1 Pakastelokero poistaminen	233
4.13.2 Pakastelokero asennus.....	233
4.14 LED-ylälampun vaihtaminen	234
4.14.1 LED-ylälampun poistaminen.....	234
4.14.2 LED-ylälampun asennus	234
4.15 LED-sivulampun vaihtaminen	235
4.15.1 LED-sivulampun poistaminen	235
4.15.2 LED-sivulampun asennus	236
4.16 LED-pakastinlampun vaihtaminen	238
4.16.1 LED-pakastinlampun poistaminen	238
4.16.2 LED-pakastinlampun asennus.....	238

Tämä asiakirja

1.1 Tärkeitä tietoja

1.1.1 Tarkoitus

Näiden korjausohjeiden tarkoituksena on auttaa kuluttajaa korjaamaan laitteita itse ekologista suunnittelua koskevan asetuksen (päivitys 03/2021) mukaisesti.



Ne sisältävät tietoja siitä, miten määrätyt varaosat voidaan vaihtaa. Lisäksi niihin sisältyy tietoja varoituksista ja riskeistä.

Ota yhteyttä huoltopalveluun, jos sinulla on kysyttävää. Vastamme vahingoista vain, jos korjausohjeita on noudatettu oikein.

1.2 Symboleiden merkitys

1.2.1 Vaaratasot

Varoitustasot koostuvat symbolista ja huomiosanasta. Huomiosanat ilmoittava vaaran vakavuuden.

Varoitustaso	Merkitys
 VAARA	Varoituksen laiminlyönti johtaa kuolemaan tai vakaviin loukkaantumisiin.
 VAROITUS	Varoituksen laiminlyönti voi johtaa kuolemaan tai vakaviin loukkaantumisiin.
 HUOMAA	Varoituksen laiminlyönti voi johtaa lieviin loukkaantumisiin.
HUOMIO!	Varoituksen laiminlyönti voi johtaa omaisuusvahinkoihin.

Taulukko 1: Vaaratasot

1.2.2 Varoitusmerkit

Varoitusmerkit ovat symboleita sisältäviä esityksiä, jotka osoittavat vaaran tyyppin.

Tässä asiakirjassa käytetään seuraavia varoitusmerkkejä:

Varoitusmerkki	Merkitys
	Yleinen varoitus
	Sähköjännitteestä aiheutuva vaara
	Räjähdysvaara
	Viiltohaavojen vaara
	Murskautumisen vaara

Tämä asiakirja

Varoitusmerkki	Merkitys
	Kuumista pinnoista aiheutuva vaara
	Voimakkaasta magneettikentästä aiheutuva vaara
	Ionisoimattomasta säteilystä aiheutuva vaara



Taulukko 2: Varoitusmerkit

1.2.3 Varoitusten rakenne

Tämän asiakirjan sisältämällä varoituksilla on standardoitu ulkonäkö ja rakenne.



	<div style="background-color: red; color: white; padding: 2px; text-align: center;"> VAARA</div> <p>Vaaran tyyppi ja lähde! Vaaran/varoituksen laiminlyönnistä mahdollisesti aiheutuvat seuraukset.</p> <ul style="list-style-type: none">▶ Vaaran ehkäisemiseen liittyvät toimenpiteet ja kiellot.
--	--

Seuraavassa esimerkissä näytetään varoitus, joka varoittaa jännitteisten osien aiheuttamasta sähköiskusta. Vaaran välttämiseksi suoritettava toimenpide mainitaan.

	<div style="background-color: red; color: white; padding: 2px; text-align: center;"> VAARA</div> <p>Jännitteisten osien aiheuttama sähköiskun vaara! Sähköiskun aiheuttama kuolema</p> <ul style="list-style-type: none">▶ Erotta laitteet sähkövirrasta vähintään 60 sekuntia ennen korjaustöiden aloittamista.
---	---

1.2.4 Yleiset symbolit

Tässä asiakirjassa käytetään seuraavia yleisiä symboleja:

Yl. symboli	Merkitys
	Erikoisohjeen tunniste (teksti ja/tai kaavio)
	Yksinkertaisen ohjeen tunniste (vain teksti)

Yl. symboli	Merkitys
	Video-opetusohjelmaan johtavan linkin tunniste
	Tarvittavien työkalujen tunniste
	Tarvittavien edellytysten tunniste
	Ehdon (jos ..., sitten ...) tunniste
	Tuloksen tunniste
	Näppäimen tai painikkeen tunniste
	Materiaalinumeron tunniste
	Näytetyn tekstin/ikkunan (laitteen näytössä) tunniste

Taulukko 3: Yleiset symbolit

2.1 Yleiset turvallisuusohjeet

2.1.1 Kaikki kotitalouskoneet

Jännitteisten osien aiheuttama sähköiskun vaara!

- Virheet sähkökomponentteja sisältävissä korjauksissa voivat johtaa sähköiskuun!
- Kytke kone irti verkkovirrasta vähintään 60 sekuntia ennen töiden aloittamista.
- Pyydä korjauksen jälkeen suorittamaan VDE 0701 -säädöksen tai maakohtaisten säädösten mukainen turvallisuustesti.

Terävistä reunoista aiheutuva loukkaantumisvaara!

- Käytä suojakäsineitä.

Painavista ja liikkuvista komponenteista aiheutuva murskautumisen riski korjauksen, kunnossapidon, vianetsinnän ja huollon aikana

- Käytä suojakenkiä.
- Estä painavien komponenttien putoaminen.
- Älä koske liikkuviin komponentteihin.

Laitteen turvallisuudelle/toiminnalle aiheutuva riski!

- Käytä vain alkuperäisiä varaosia.

Staattiselle sähkölle herkkien komponenttien (ESDS) vaurioitumisen riski!

- Älä koske moduuleihin, liitännät ja johdinreitit mukaan luettuna.

Työkalut ja apuvälineet

Nimitys	Yksityiskohdat	Kuvat
Torx-kärki TX20 [00340865]	6,3 mm (1/4")	
Erikoistyökalu [00342180]		

4.1 Oven tiivisteiden vaihtaminen

Vaatus:

- ✓ Ovi on auki.

4.1.1 Oven tiivisteiden poistaminen

1. Irrota oven tiiviste urasta oikeassa ja vasemmassa nurkassa.

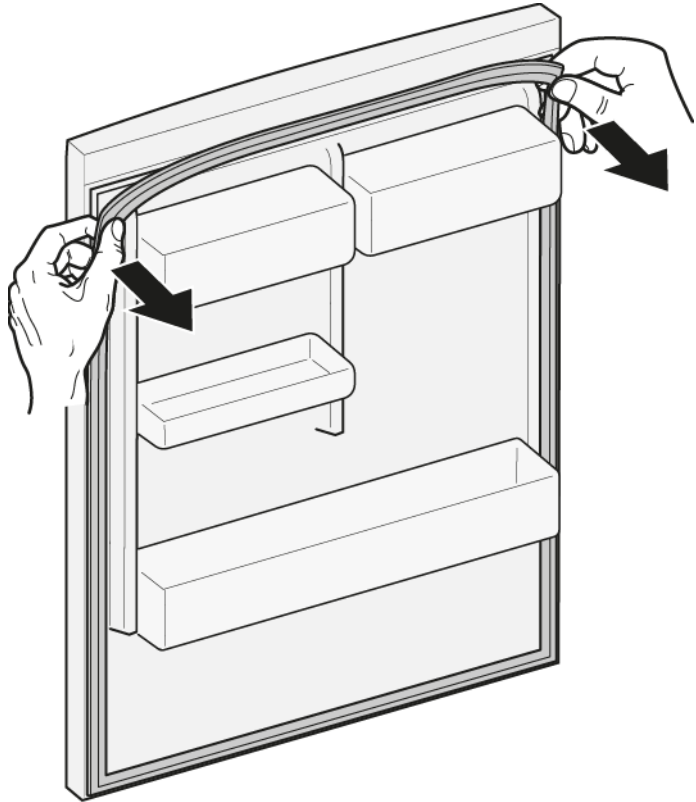

2. Vedä oven tiiviste ulos urasta.

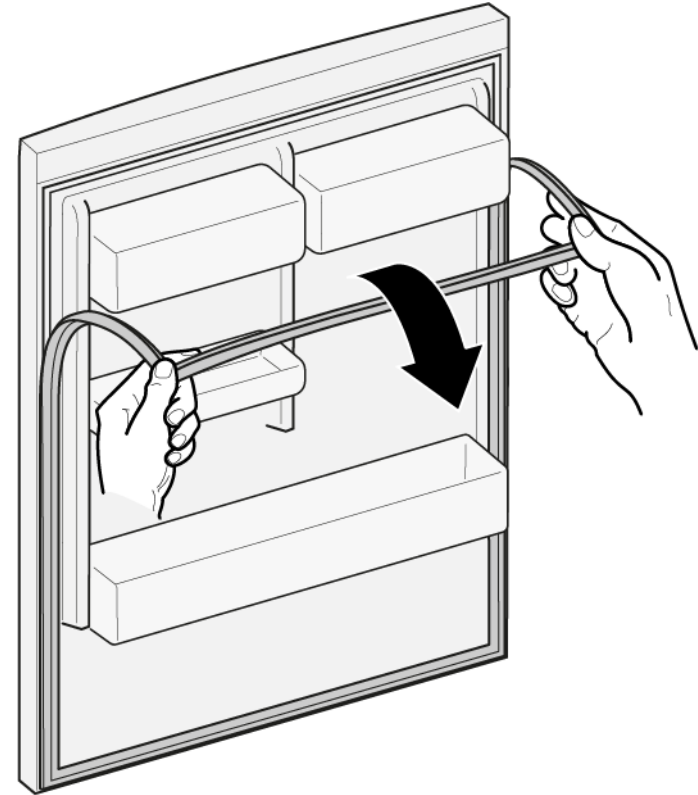

- ➡ Oven tiiviste on poistettu.

4.1.2 Oven tiivisteiden asennus





Uuden tiivisteiden paksuus voi poiketa hieman vanhan tiivisteiden paksuudesta. Sillä ei ole vaikutusta oven sulkeutumiseen eikä pitkän aikavälin toimintaan.

Jos laitteessa on säädettävät saranat tai saranan kiinnittimet, voit optimoida sulkeutumista myöhemmin.

Oven tiivisteiden sivuilla olevat pienet reiät ovat toiminnollisia (tarvitaan ilmanvaihtoa varten). Ne eivät ole tuotantovirheitä.

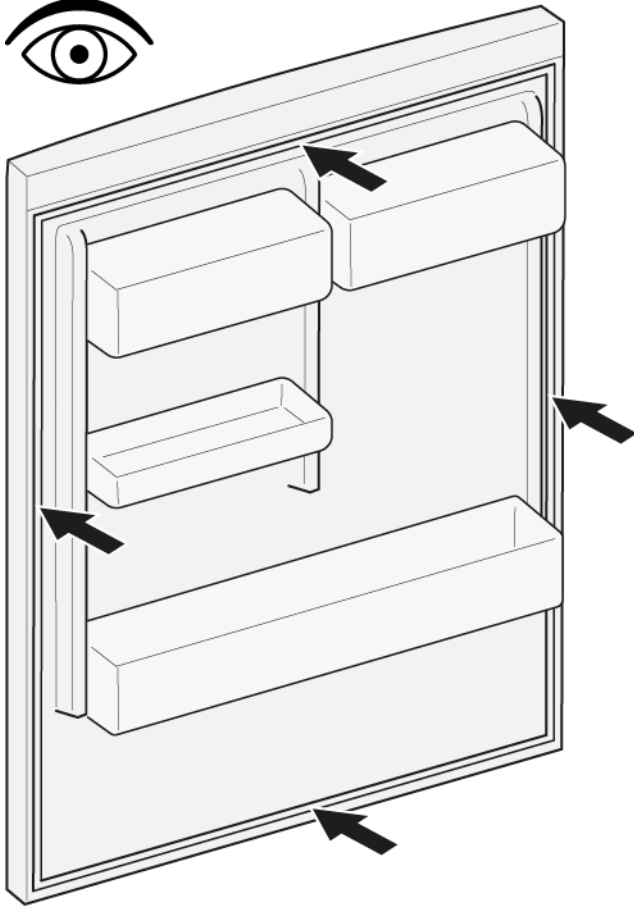
1. Tarkista, että tiivistettä varten oleva ura ei ole vioittunut.



2.  Jos tiivisteen ura on vioittunut.
- Ota yhteyttä asiakaspalveluun.

3.  Oven tiivisteen pienet vääntymät ovat normaaleja eikä niillä ole vaikutusta sen toimintaan. Oven tiiviste kannattaa suoristaa, ennen kuin se asetetaan laitteeseen.

Kuumenna oven tiivistettä hiustenkuivaajalle tai kuumalla vedellä ja muotoile se käsin uudelleen.

4. Työnnä tiivisteen nurkat ylhäällä ja alhaalla uraan.

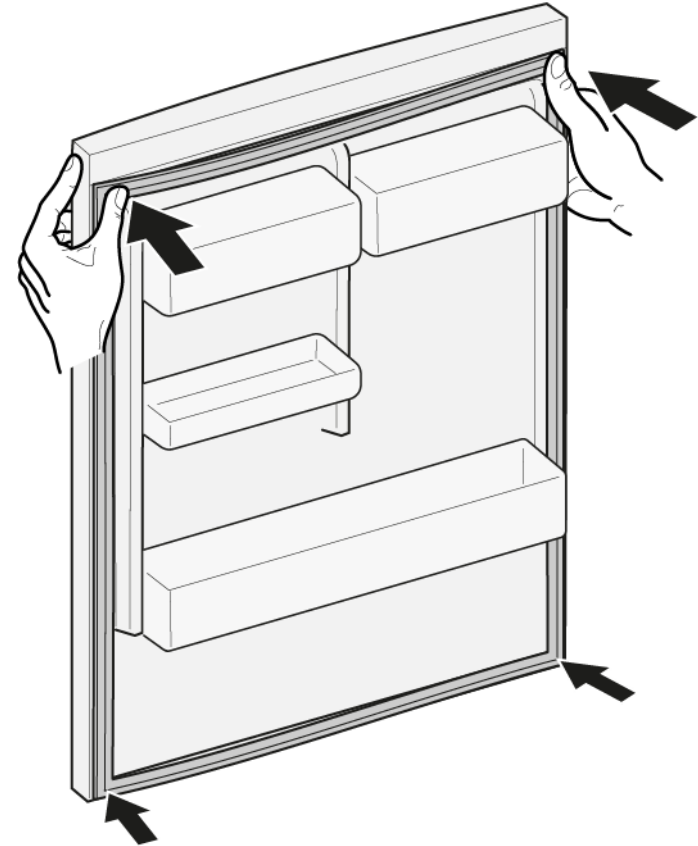

5. Paina koko tiiviste vähitellen uraan.

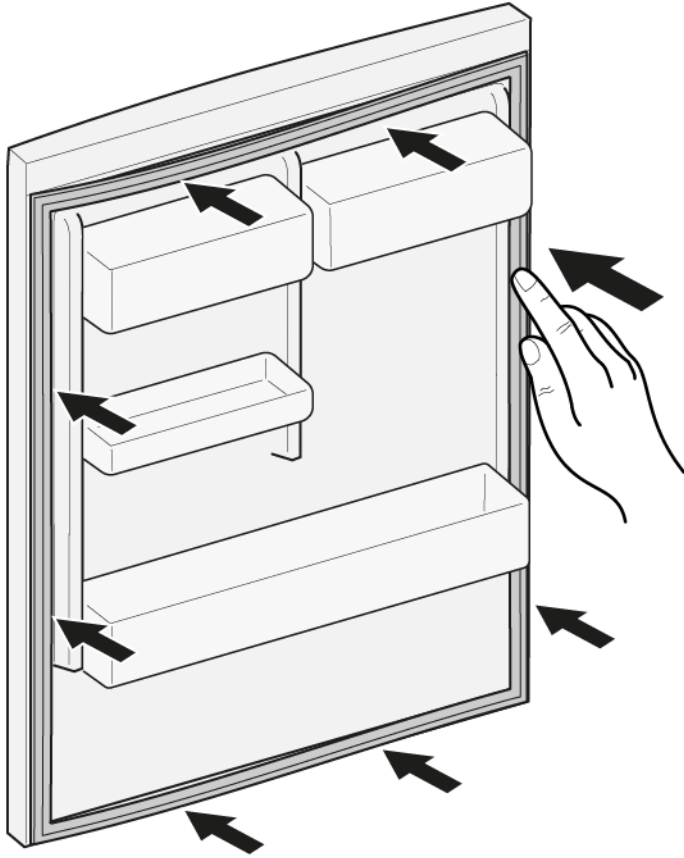

 Oven tiiviste on asennettu.

4.2 Ovenkahvan vaihtaminen

Erikoistyökalut:

- Torx-kärki TX20 6,3 mm (1/4") [00340865]
- Uruuvimeisseli Terä 10 mm x 1,6 mm x 200 mm

Vaatus:

- ✓ Kone on erotettu tehollisesta.
- ✓ Ovi on auki.

4.2.1 Ovenkahvan poistaminen

- 1. Poista kaksi ruuvia suojusta (1).
- 2. Kierrä kaksi ruuvia auki (2).
- 3. Poista ovenkahva (3).

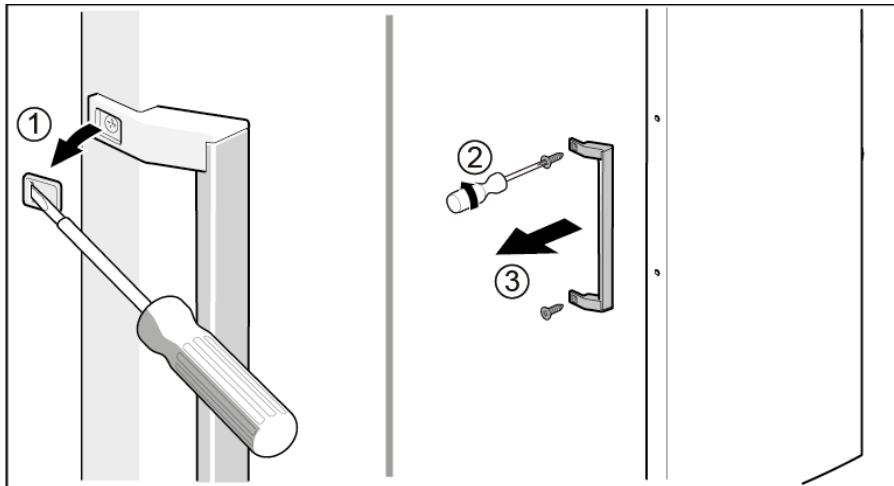

➡ Ovenkahva on poistettu.



Toisen oven ovenkahva voidaan poistaa samalla tavalla.

4.2.2 Ovenkahvan asennus

- Asenna vastakkaisessa järjestyksessä.

4.3 Oven yläsaranan vaihtaminen

Erikoistyökalut:

Torx-kärki TX20

6,3 mm (1/4")

[00340865]



VAROITUS

Painavat, isokokoiset laitteet!

Selän ja lihasten vammat

- ▶ Vain koulutettujen ammattilaisten tulisi suorittaa laitteen oven poistamiseen liittyvät vaiheet.
- ▶ Laitteen siirtämiseen tarvitaan kahta ihmistä.
- ▶ Käytä vain soveltuvia työkaluja ja välineitä.



HUOMAA

Terävät reunat!

Viiltovammat

- ▶ Käytä suojakäsineitä.



VAROITUS

Kallistetun koneen luiskahtaminen.!

Luunmurtumat/murskavammat

- ▶ Estä koneiden luiskahtaminen.



HUOMAA

Ruuvien avaamisesta aiheutuva osien putoamisen riski!

Loukkaantuminen putoavien osien vuoksi.

- ▶ Estä komponentin putoaminen.



HUOMIO!

Ruuvien avaamisesta aiheutuva osien putoamisen riski!

Vauriot koneen muille osille tai asiakkaan kodille, esim. lattia.

- ▶ Estä komponentin putoaminen.

Vaatus:

- ✓ Kone on erotettu teholähteestä.
- ✓ Laitteen sisällä olevat lisävarusteet on poistettu.

4.3.1 Oven yläsaranan poistaminen

1. Liu'uta kannatteleva osa kantaosan alle.

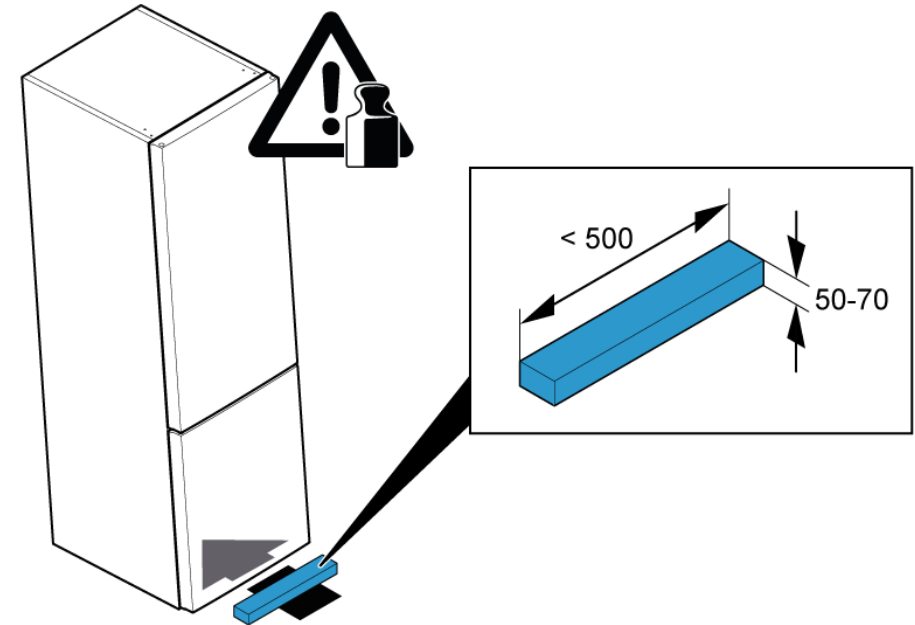

2. 1. Poista yläsaranan suojus (1).
2. Kierrä kaksi ruuvia auki (2).
3. Poista yläsarana (3).

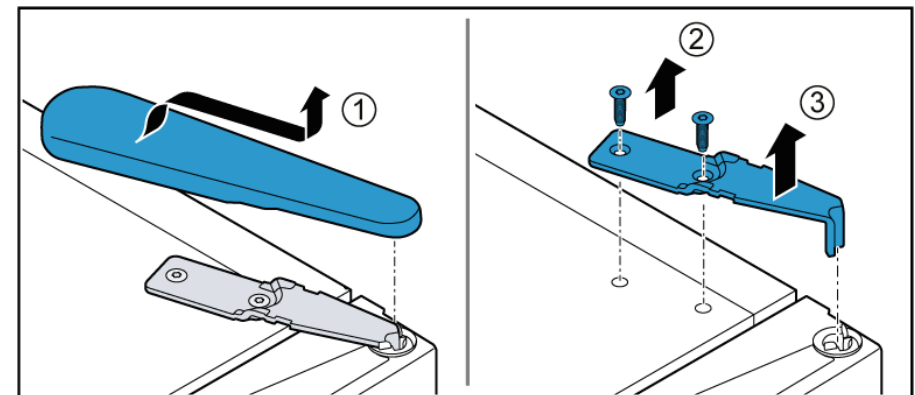

3. Poista ylempi ovi.

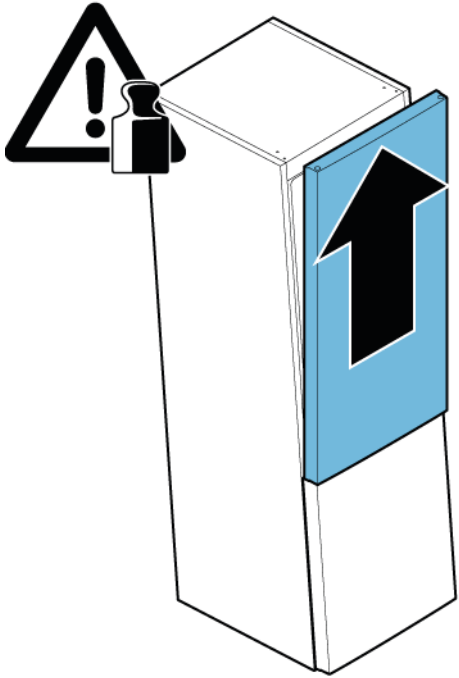

 Yläsarana on poistettu.



4.3.2 Oven yläsaranan asennus



- ▶ Asenna vastakkaisessa järjestyksessä.

4.4 Oven yläsaranan vaihtaminen (näytöllä varustettu ovi)



Erikoistyökalut:

 Torx-kärki TX20 6,3 mm (1/4") [00340865]

	 VAROITUS
	<p>Painavat, isokokoiset laitteet! Selän ja lihasten vammat</p> <ul style="list-style-type: none"> ▶ Vain koulutettujen ammattilaisten tulisi suorittaa laitteen oven poistamiseen liittyvät vaiheet. ▶ Laitteen siirtämiseen tarvitaan kahta ihmistä. ▶ Käytä vain soveltuvia työkaluja ja välineitä.



	 HUOMAA
	<p>Terävät reunat! Viiltovammat</p> <ul style="list-style-type: none"> ▶ Käytä suojakäsineitä.

	 VAROITUS
	<p>Kallistetun koneen luiskahtaminen.! Luunmurtumat/murskavammat</p> <ul style="list-style-type: none"> ▶ Estä koneiden luiskahtaminen.



	 HUOMAA
	<p>Ruuvien avaamisesta aiheutuva osien putoamisen riski! Loukkaantuminen putoavien osien vuoksi.</p> <ul style="list-style-type: none"> ▶ Estä komponentin putoaminen.

	HUOMIO!
	<p>Ruuvien avaamisesta aiheutuva osien putoamisen riski! Vauriot koneen muille osille tai asiakkaan kodille, esim. lattia.</p> <ul style="list-style-type: none"> ▶ Estä komponentin putoaminen.

	 VAARA
	<p>Jännitteisten osien aiheuttama sähköiskun vaara! Sähköiskusta aiheutuva hengenvaara väärän korjauksen tapauksessa</p> <ul style="list-style-type: none"> ▶ Sähköosien korjaus tulisi antaa pätevien sähköasentajien suoritettavaksi. ▶ Pyydä korjauksen jälkeen suorittamaan VDE 0701 -säädöksen tai maakohtaisten säädösten mukainen turvallisuustesti.

	 VAARA
	<p>Jännitteisten osien aiheuttama sähköiskun vaara! Sähköiskun aiheuttama kuolema</p> <ul style="list-style-type: none"> ▶ Erotta laitteet sähkövirrasta vähintään 60 sekuntia ennen korjaustöiden aloittamista.

Vaatus:

-  Kone on erotettu teholahteesta.
-  Laitteen sisällä olevat lisävarusteet on poistettu.

4.4.1 Oven yläsaranan poistaminen

1. Liu'uta kannatteleva osa kantaosan alle.

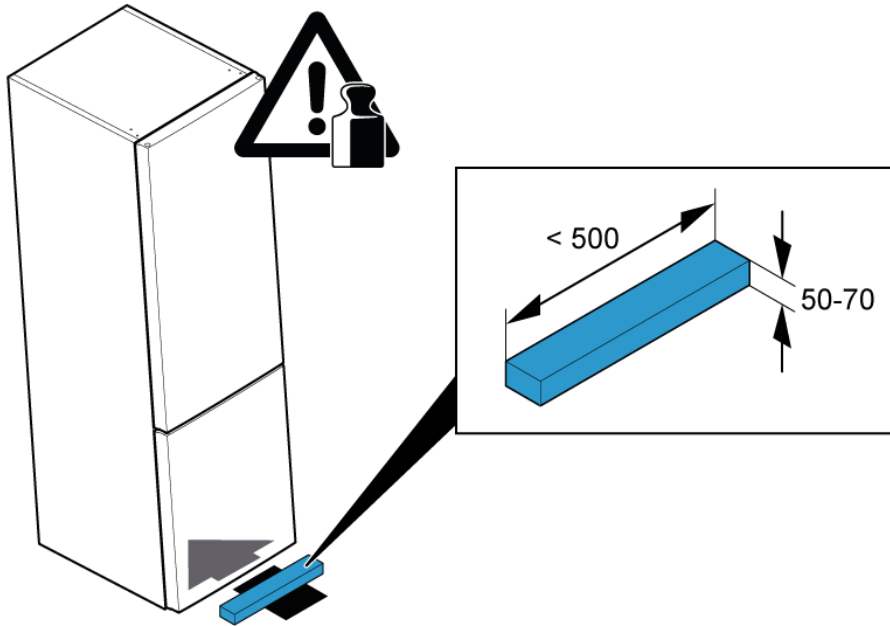

2. 1. Poista yläsaranan suojus (1).
2. Irrota sähköliitäntä (2).
3. Kierrä maadoitusliitännän ruuvi auki (3).

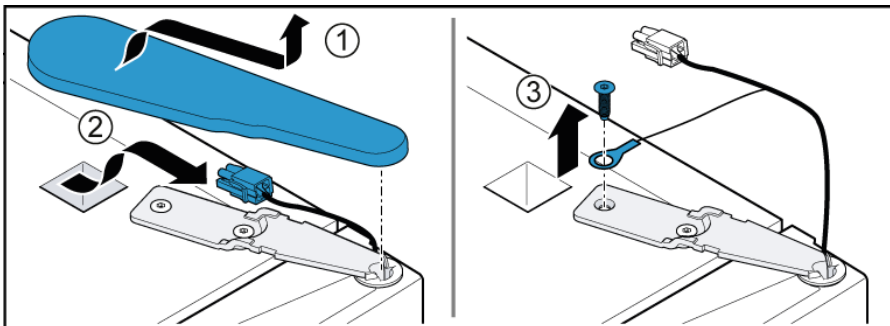

3. 1. Kierrä ruuvi auki (1).
2. Poista yläsarana (2).

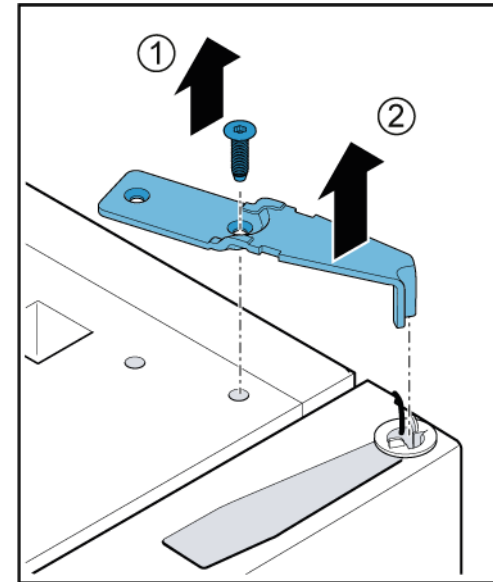

4. Poista ylempi ovi.

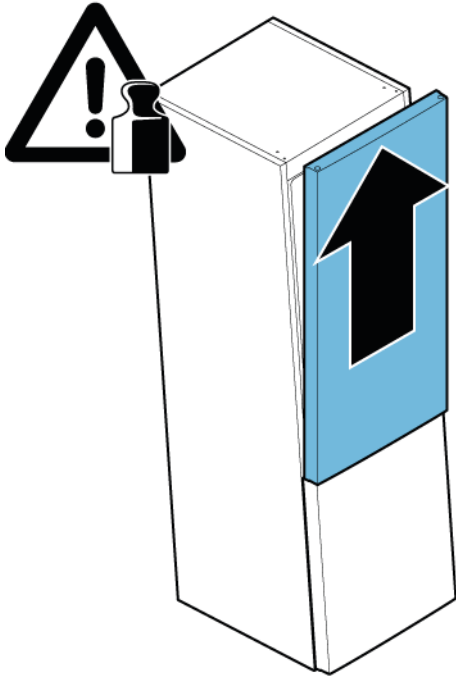

 Yläsarana on poistettu.

4.4.2 Oven yläsaranan asennus

- ▶ Asenna vastakkaisessa järjestyksessä.

4.5 Oven keskisaranan vaihtaminen

Erikoistyökalut:

Torx-kärki TX20

6,3 mm (1/4")

[00340865]



VAROITUS

Painavat, isokokoiset laitteet!

Selän ja lihasten vammat

- ▶ Vain koulutettujen ammattilaisten tulisi suorittaa laitteen oven poistamiseen liittyvät vaiheet.
- ▶ Laitteen siirtämiseen tarvitaan kahta ihmistä.
- ▶ Käytä vain soveltuvia työkaluja ja välineitä.



HUOMAA

Terävät reunat!

Viiltovammat

- ▶ Käytä suojakäsineitä.



VAROITUS

Kallistetun koneen luiskahtaminen.!

Luunmurtumat/murskavammat

- ▶ Estä koneiden luiskahtaminen.



HUOMAA

Ruuvien avaamisesta aiheutuva osien putoamisen riski!

Loukkaantuminen putoavien osien vuoksi.

- ▶ Estä komponentin putoaminen.



HUOMIO!

Ruuvien avaamisesta aiheutuva osien putoamisen riski!

Vauriot koneen muille osille tai asiakkaan kodille, esim. lattia.

- ▶ Estä komponentin putoaminen.

Vaatus:

- ✓ Kone on erotettu teholähteestä.
- ✓ Laitteen sisällä olevat lisävarusteet on poistettu.
- ✓ Oven yläsarana on poistettu.
- ✓ Yläovi on poistettu.

4.5.1 Oven keskisaranan poistaminen

1. Kierrä kaksi ruuvia auki (1).
2. Poista keskisarana (2).

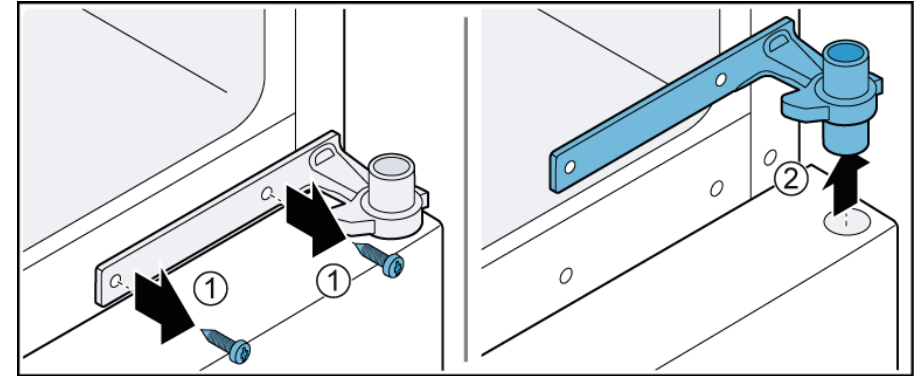

2. Poista alempi ovi.

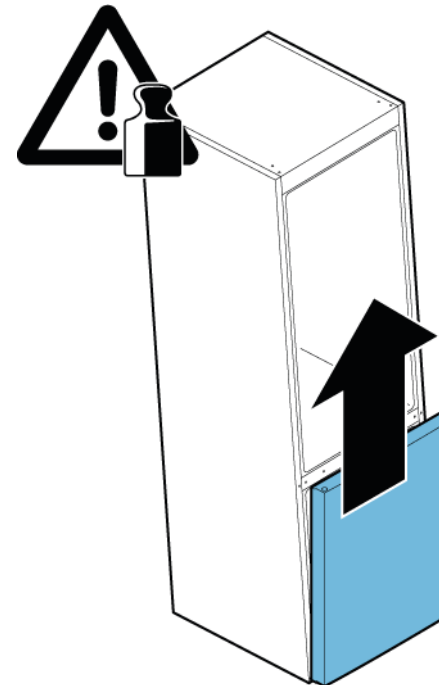

- ➡ Keskisarana on poistettu.

4.5.2 Oven keskisaranan asennus

- ▶ Asenna vastakkaisessa järjestyksessä.





4.6 Oven alasaranan vaihtaminen

Erikoistyökalut:

Torx-kärki TX20

6,3 mm (1/4")

[00340865]

	<p style="text-align: center;">VAROITUS</p> <p>Painavat, isokokoiset laitteet! Selän ja lihasten vammat</p> <ul style="list-style-type: none"> ▶ Vain koulutettujen ammattilaisten tulisi suorittaa laitteen oven poistamiseen liittyvät vaiheet. ▶ Laitteen siirtämiseen tarvitaan kahta ihmistä. ▶ Käytä vain soveltuvia työkaluja ja välineitä.
	<p style="text-align: center;">HUOMAA</p> <p>Terävät reunat! Viiltovammat</p> <ul style="list-style-type: none"> ▶ Käytä suojakäsineitä.
	<p style="text-align: center;">VAROITUS</p> <p>Kallistetun koneen luiskahtaminen.! Luunmurtumat/murskavammat</p> <ul style="list-style-type: none"> ▶ Estä koneiden luiskahtaminen.
	<p style="text-align: center;">HUOMAA</p> <p>Ruuvien avaamisesta aiheutuva osien putoamisen riski! Loukkaantuminen putoavien osien vuoksi.</p> <ul style="list-style-type: none"> ▶ Estä komponentin putoaminen.
	<p style="text-align: center;">HUOMIO!</p> <p>Ruuvien avaamisesta aiheutuva osien putoamisen riski! Vauriot koneen muille osille tai asiakkaan kodille, esim. lattia.</p> <ul style="list-style-type: none"> ▶ Estä komponentin putoaminen.

Vaatus:

- ✔ Kone on erotettu teholähteestä.
- ✔ Laitteen sisällä olevat lisävarusteet on poistettu.
- ✔ Yläsarana on poistettu.
- ✔ Keskisarana on poistettu.

4.6.1 Oven alasaranan poistaminen

- ▶ 1. Kierrä kaksi ruuvia auki (1).
- ▶ 2. Poista alasarana (2).

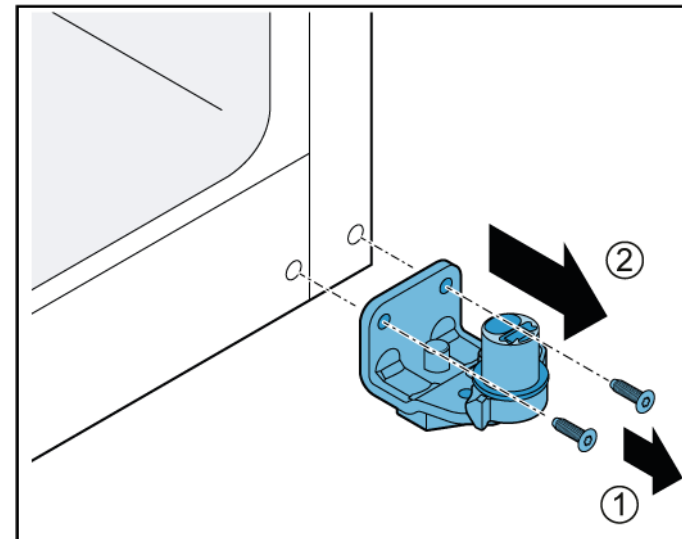

➡ Oven alasarana on poistettu.

4.6.2 Oven alasaranan asennus

- ▶ Asenna vastakkaisessa järjestyksessä.

4.7 Hyllyn vaihtaminen

Vaatus:

- ✔ Ovi on auki.

4.7.1 Hyllyn poistaminen

- ▶ 1. Nosta hylly takana (1).
- ▶ 2. Vapauta hylly (2).

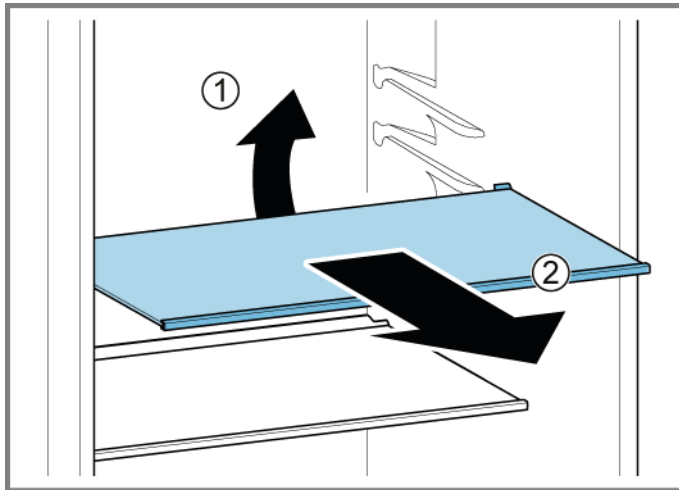

➡ Hylly on poistettu.

4.7.2 Hyllyn asennus

- ▶ Asenna vastakkaisessa järjestyksessä.

4.8 Pullohyllyn vaihtaminen

Vaatus:

- ✔ Ovi on auki.

4.8.1 Pullohyllyn poistaminen

- ▶ Vedä pullohylly ulos.

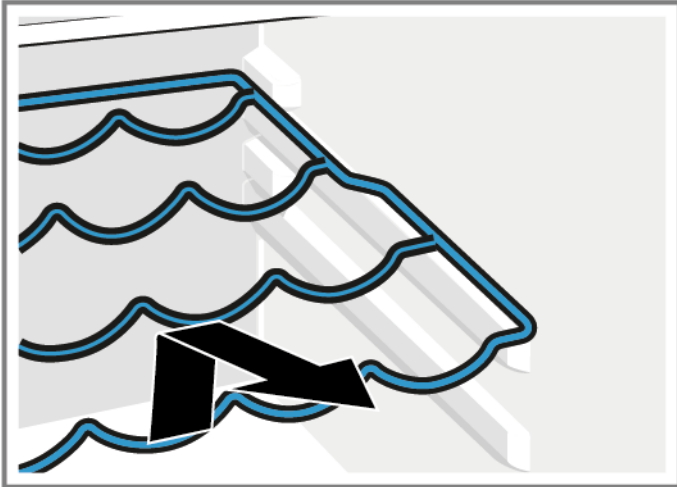

- ➡ Pullohylly on poistettu.

4.8.2 Pullohyllyn asennus

- ▶ Asenna vastakkaisessa järjestyksessä.

4.9 Ovihyllyn vaihtaminen

Vaatus:

- ✔ Ovi on auki.

4.9.1 Ovihyllyn poistaminen

- ▶ Nosta ovihylly pois yläsuuntaan.

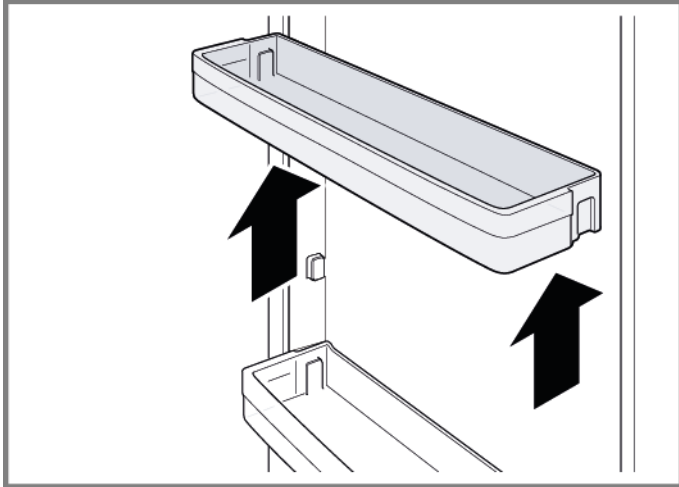

➡ Ovihylly on poistettu.

4.9.2 Ovihyllyn asennus

- ▶ Asenna vastakkaisessa järjestyksessä.

4.10 Säilytyslokeron vaihtaminen

Vaatus:

- ✔ Ovi on auki.

4.10.1 Säilytyslokeron poistaminen

1. Vedä säilytyslokero niin ulos kuin se tulee.
2. 1. Nosta säilytyslokeroa edessä (1).
2. Poista lokero (2).

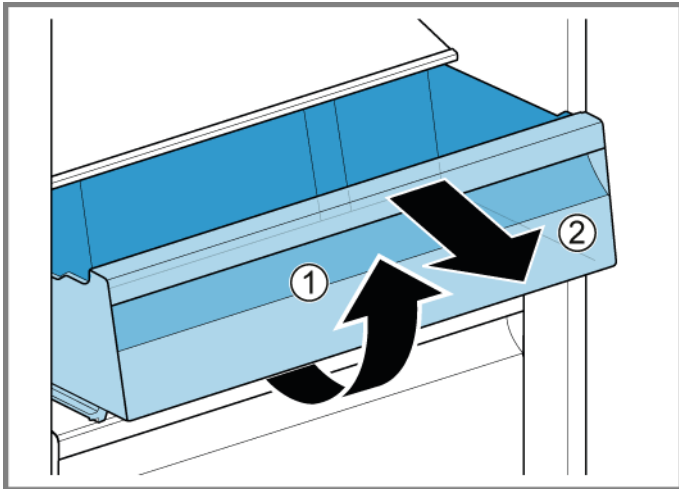

- ➔ Säilytyslokero on poistettu.

4.10.2 Säilytyslokeron asennus

- ▶ Asenna vastakkaisessa järjestyksessä.

4.11 Hedelmä- ja vihanneslokeron vaihtaminen

Vaatus:

- ✔ Ovi on auki.

4.11.1 Hedelmä- ja vihanneslokeron poistaminen

1. Vedä hedelmä- ja vihanneslokeron ulos niin paljon kuin se tulee.
2. 1. Nosta hedelmä- ja vihanneslokeron edessä (1).
2. Poista lokero (2).

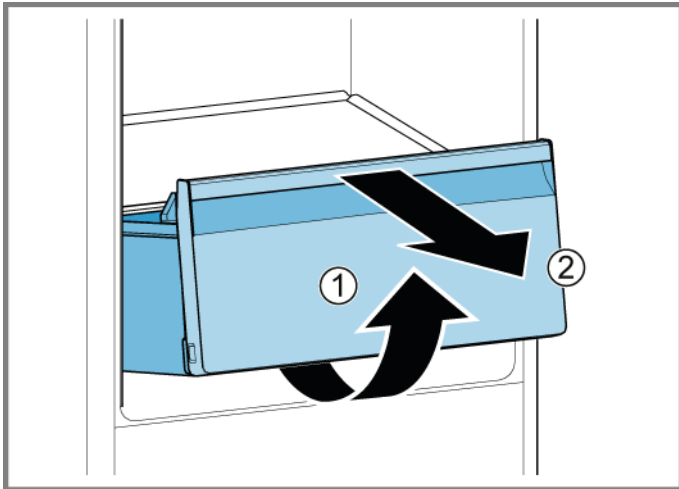

- ➡ Hedelmä- ja vihanneslokeron on poistettu.

4.11.2 Hedelmä- ja vihanneslokeron asennus

- ▶ Asenna vastakkaisessa järjestyksessä.

4.12 Hedelmä- ja vihanneslokeron yläpuolella olevan hyllyn vaihtaminen

Vaatus:

- ✓ Ovi on auki.
- ✓ [Hedelmä- ja vihanneslokeron poistettu. → 230](#)

4.12.1 Hedelmä- ja vihanneslokeron yläpuolella olevan hyllyn vaihtaminen

1. Työnnä tiivisterunkoa ylöspäin ja ulos.

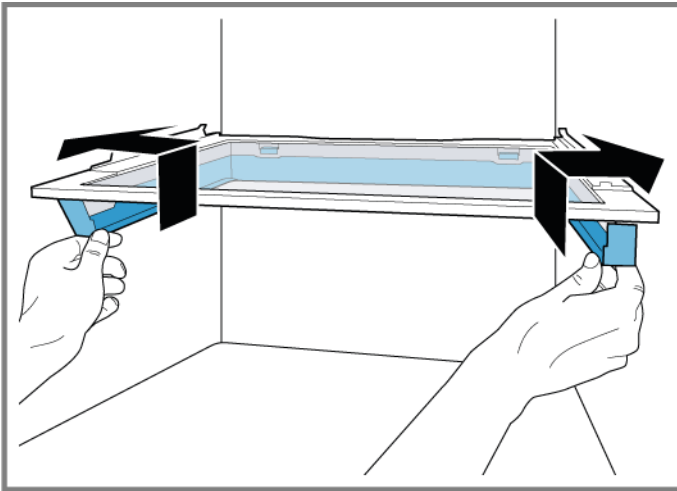

➡ Sivukoukut on vapautettu.

2. Nosta tiivisterunko ylös ja liu'uta taaksepäin.

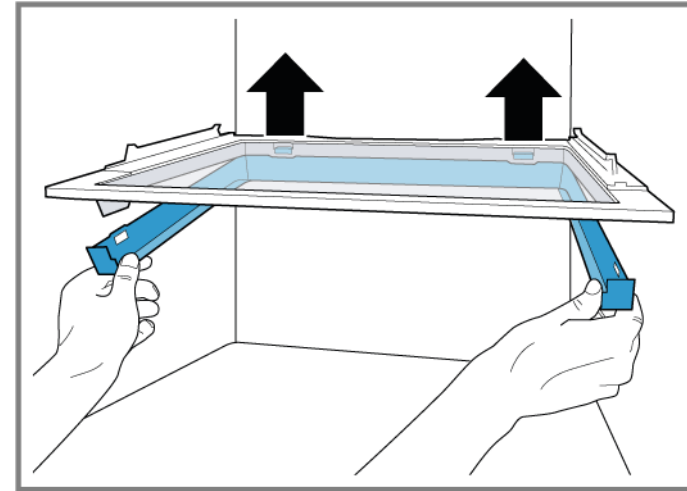

➡ Takakoukut on vapautettu.

3. Poista tiivisterunko.
4. Nosta hedelmä- ja vihanneslokeron yläpuolella olevaa hyllyä ja vedä se ulos sivuttain kääntämällä.

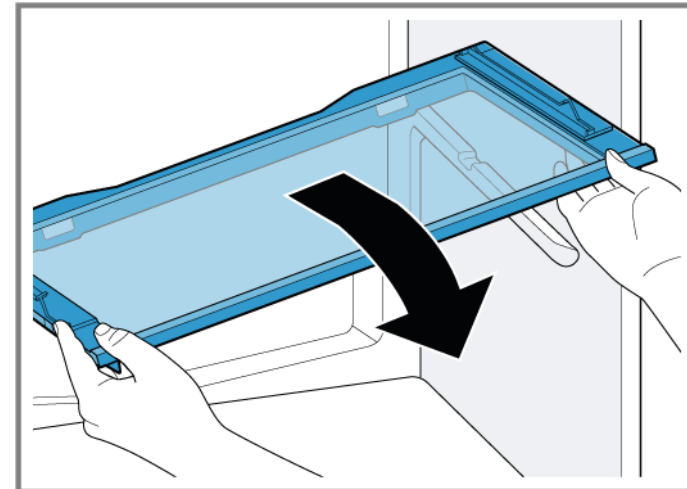

➡ Hedelmä- ja vihanneslokeron yläpuolella oleva säiliö on poistettu.

4.12.2 Hedelmä- ja vihanneslokeron yläpuolella olevan hyllyn asennus

- ▶ Asenna vastakkaisessa järjestyksessä.

4.13 Pakastelokeron vaihtaminen

Vaatus:

- ✔ Ovi on auki.

4.13.1 Pakastelokeron poistaminen

- ▶ 1. Vedä pakastelokero kokonaan ulos (1).
- ▶ 2. Poista lokero (2).

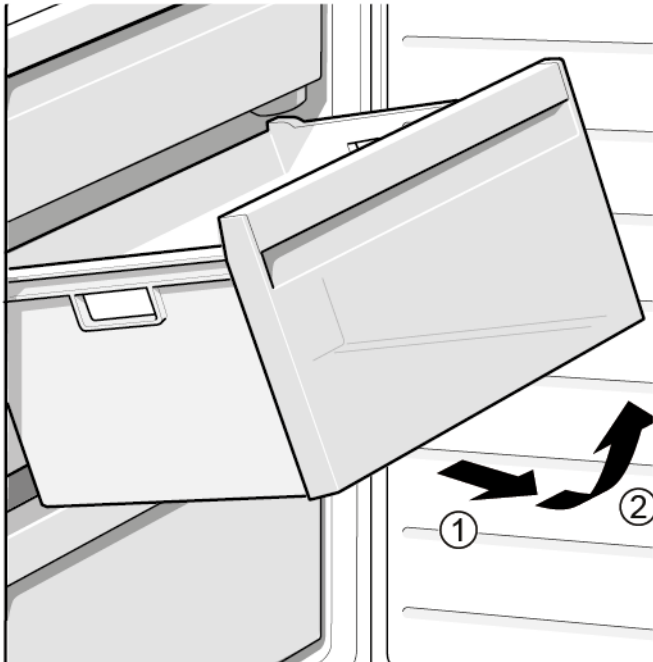

- ➡ Pakastelokero on poistettu.

4.13.2 Pakastelokeron asennus

- ▶ Asenna vastakkaisessa järjestyksessä.

4.14 LED-ylälampun vaihtaminen

Erikoistyökalut:

Erikoistyökalu [00342180]

i Laite on varustettu huoltovapaalla LED-valolla.
Vain huoltopalvelu tai valtuutetut teknikot saavat korjata nämä valot!

⚠ VAARA
Jännitteisten osien aiheuttama sähköiskun vaara!
Sähköiskusta aiheutuva hengenvaara väärän korjauksen tapauksessa

- ▶ Sähköosien korjaus tulisi antaa pätevien sähköasentajien suoritettavaksi.
- ▶ Pyydä korjauksen jälkeen suorittamaan VDE 0701 -säädöksen tai maakohtaisten säädösten mukainen turvallisuustesti.

⚠ VAARA
Jännitteisten osien aiheuttama sähköiskun vaara!
Sähköiskun aiheuttama kuolema

- ▶ Erotta laitteet sähkövirrasta vähintään 60 sekuntia ennen korjaustöiden aloittamista.

⚠ HUOMAA
Terävät reunat!
Viiltovammat

- ▶ Käytä suojakäsineitä.

Vaatus:

- ✔ Kone on erotettu teholahteesta.
- ✔ Ovi on auki.

4.14.1 LED-ylälampun poistaminen

1. Liu'uta irrotustyökalu LED-ylälampun ja jääkaappiosan sisävaipan väliin lampun koukkujen vapauttamiseksi (1).
2. Poista LED-ylälamppu (2).

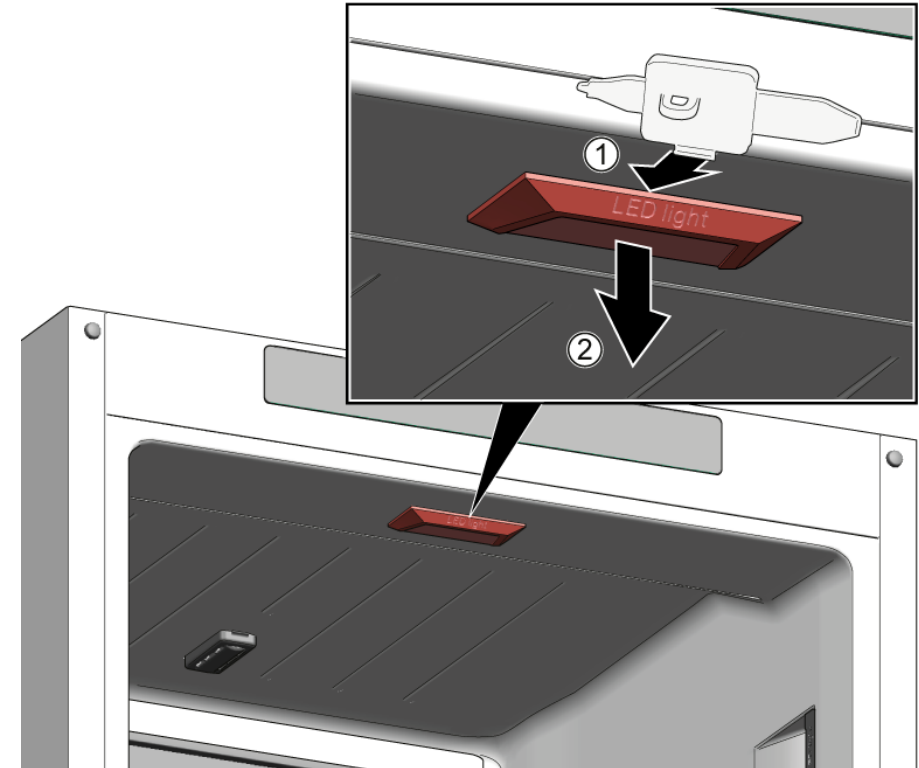

2. Irrota LED-ylälampun sähköliitäntä.
- ➡ LED-ylälamppu on poistettu.

4.14.2 LED-ylälampun asennus

- ▶ Asenna vastakkaisessa järjestyksessä.

4.15 LED-sivulampun vaihtaminen

Erikoistyökalut:

Erikoistyökalu [00342180]

i Laite on varustettu huoltovapaalla LED-valolla.
Vain huoltopalvelu tai valtuutetut teknikot saavat korjata nämä valot!

VAARA
Jännitteisten osien aiheuttama sähköiskun vaara!
Sähköiskusta aiheutuva hengenvaara väärän korjauksen tapauksessa

- ▶ Sähköosien korjaus tulisi antaa pätevien sähköasentajien suoritettavaksi.
- ▶ Pyydä korjauksen jälkeen suorittamaan VDE 0701 -säädöksen tai maakohtaisten säädösten mukainen turvallisuustesti.

VAARA
Jännitteisten osien aiheuttama sähköiskun vaara!
Sähköiskun aiheuttama kuolema

- ▶ Erotta laitteet sähkövirrasta vähintään 60 sekuntia ennen korjaustöiden aloittamista.

HUOMAA
Terävät reunat!
Viiltovammat

- ▶ Käytä suojakäsineitä.

HUOMIO!
Staattiselle sähköille herkkien komponenttien (ESD) vaurioitumisen riski!!
Komponentit vahingoittuvat

- ▶ Ennen koskettamista ESD-komponenttiin käytä elektrostaattista suojajärjestelmää (rannehihna maadoitustulpalla).
- ▶ Älä koske moduulien liitäntöihin, johdinreitteihin mukaan luettuna.
- ▶ Kuljeta ESD-komponentteja sähköä johtavissa materiaaleissa tai alkuperäisissä pakkauksissa.
- ▶ Pidä ESD-komponentit poissa sähköisesti latautuvista materiaaleista (esim. muovista).

Vaatus:

- ✓ Kone on erotettu teholähteestä.
- ✓ Ovi on auki.
- ✓ Sisällä olevat RC-lisävarusteet on poistettu.

4.15.1 LED-sivulampun poistaminen

1. Liu'uta irrotustyökalu lampun diffuusin ja kotelon väliin koukun vapauttamiseksi (1).
2. Siirrä lampun diffuusiore ulos (2).
3. Vapauta sen jälkeiset diffuusin kiinnityskoukut samalla tavalla.

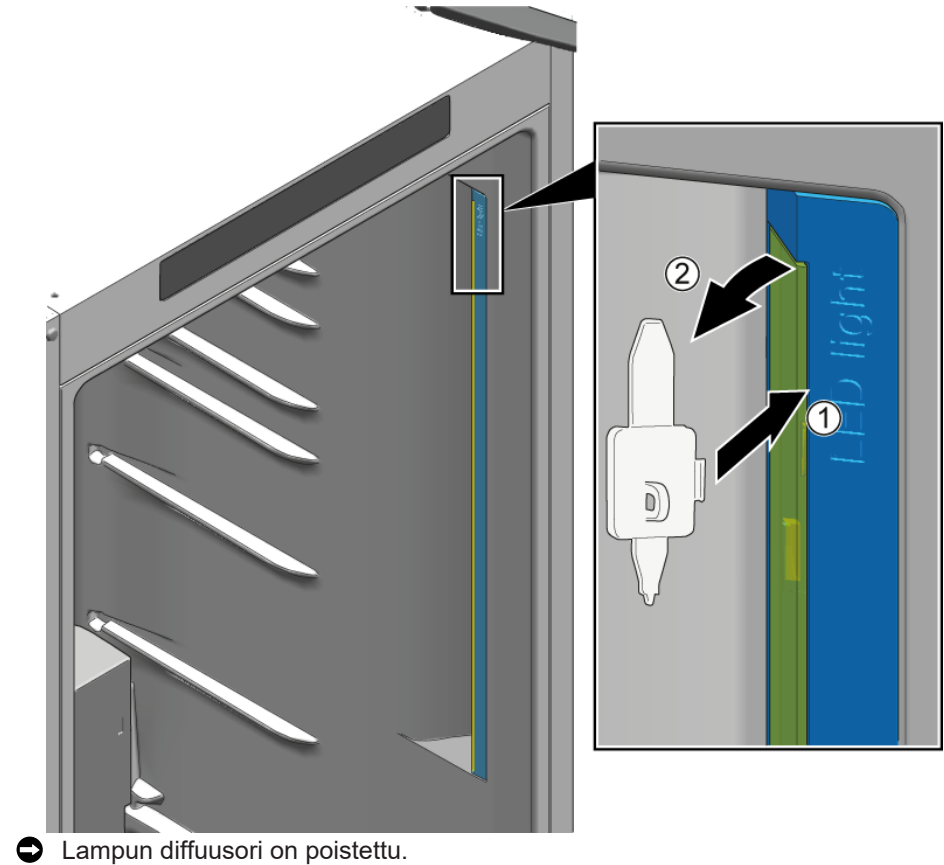

1. Paina kiinnityskoukkaa sen vapauttamiseksi (1).
2. Siirrä irrotustyökalua LED-moduulin ollessa ylhäällä noin 1 cm, jolloin LED-moduuli irtoaa sähköpistorasiasta (2).
3. Poista LED-moduuli (3).

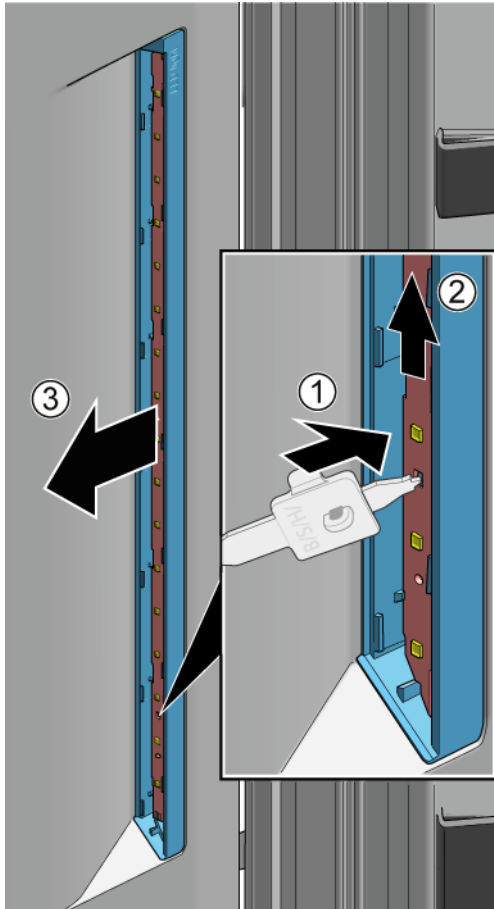

 LED-sivulamppu on poistettu.

4.15.2 LED-sivulampun asennus



Lampun diffuusorin koukut rikkoutuvat helposti poistamisen aikana. LED-sivulampun varaosa on setti, joka sisältää LED-moduulin ja lampun diffuusorin.

1. Liu'uta irrotustyökalu lampun diffuusorin ja kotelon väliin koukun vapauttamiseksi (1).
2. Siirrä lampun diffuusori ulos (2).
3. Vapauta sen jälkeiset diffuusorin kiinnityskoukut samalla tavalla.

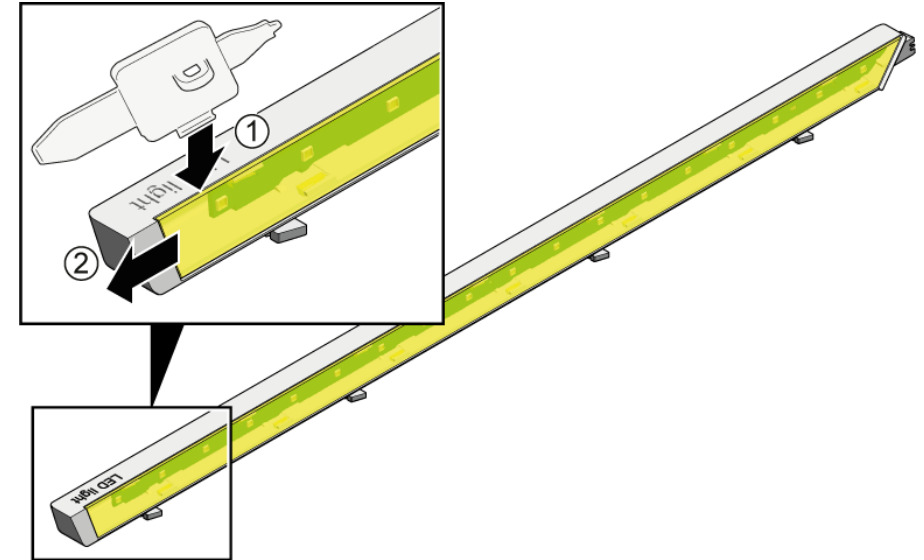

Korjaus

1. Paina kiinnityskoukkua sen vapauttamiseksi (1).
2. Liu'uta LED-moduuli yläkautta ulos kotelosta.
3. Romuta varaosien turvalliseen kuljettamiseen käytettävä LED-moduulikotelo (3).

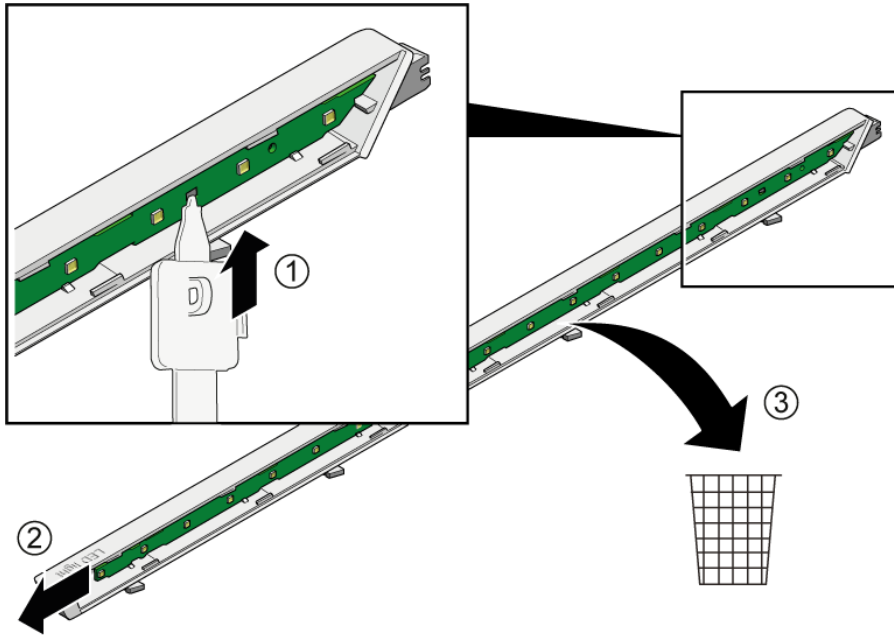

3. Asenna LED-moduuli ja lampudiffuusori vastakkaisessa järjestyksessä kuin se irrotettiin.

4.16 LED-pakastinlampun vaihtaminen

Erikoistyökalut:

Erikoistyökalu [00342180]

i Laite on varustettu huoltovapaalla LED-valolla.
Vain huoltopalvelu tai valtuutetut teknikot saavat korjata nämä valot!

⚠ VAARA
Jännitteisten osien aiheuttama sähköiskun vaara!
Sähköiskusta aiheutuva hengenvaara väärän korjauksen tapauksessa

- ▶ Sähköosien korjaus tulisi antaa pätevien sähköasentajien suoritettavaksi.
- ▶ Pyydä korjauksen jälkeen suorittamaan VDE 0701 -säädöksen tai maakohtaisten säädösten mukainen turvallisuustesti.

⚠ VAARA
Jännitteisten osien aiheuttama sähköiskun vaara!
Sähköiskun aiheuttama kuolema

- ▶ Erotta laitteet sähkövirrasta vähintään 60 sekuntia ennen korjaustöiden aloittamista.

⚠ HUOMAA
Terävät reunat!
Viiltovammat

- ▶ Käytä suojakäsineitä.

Vaatus:

- ✔ Kone on erotettu teholahteesta.
- ✔ Ovi on auki.

4.16.1 LED-pakastinlampun poistaminen

- ▶ 1. Liu'uta irrotustyökalu lampun ja kotelon väliin lampun sivulla raon (1) aikaansaamiseksi.
- ▶ 2. Liu'uta irrotustyökalu lampun kiinnityskoukun ulkopuolella ja kierrä sitä eteenpäin (2).
- ▶ 3. Poista LED-pakastinlamppu (3).

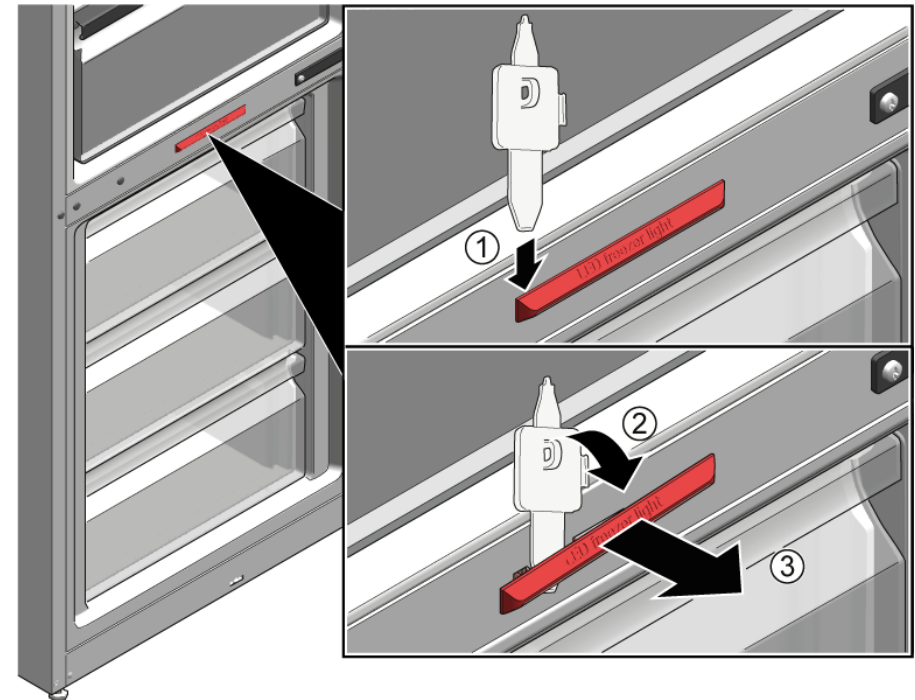





- ➡ LED-pakastinlamppu on irrotettu.
- ➡ LED-pakastinlamppu on poistettu.

4.16.2 LED-pakastinlampun asennus

- ▶ Asenna vastakkaisessa järjestyksessä.

Conseils de réparation - Réfrigérateur / Congélateur combiné

 A propos de ce document	240	4.8 Remplacer le casier à bouteilles	257
1.1 Informations importantes.....	240	4.8.1 Retirer le casier à bouteilles	257
1.1.1 Objectif.....	240	4.8.2 Monter le casier à bouteilles.....	257
1.2 Explication des symboles.....	240	4.9 Remplacer l'étagère de la porte	258
1.2.1 Niveaux de risque	240	4.9.1 Retirer l'étagère de la porte	258
1.2.2 Symboles de danger	240	4.9.2 Monter l'étagère de la porte.....	258
1.2.3 Structure des indications d'avertissement	241	4.10 Remplacer le bac de stockage	259
1.2.4 Symboles généraux	241	4.10.1 Retirer le bac de stockage.....	259
 Sécurité	242	4.10.2 Monter le bac de stockage	259
2.1 Consignes de sécurité générales.....	242	4.11 Remplacer le bac de fruits et légumes.....	260
2.1.1 Tous les appareils électroménagers	242	4.11.1 Retirer le bac de fruits et légumes	260
 Outils et aides	243	4.11.2 Monter le bac de fruits et légumes	260
 Réparation	244	4.12 Remplacer la tablette au-dessus du bac de fruits et légumes.....	261
4.1 Remplacer le joint de porte	244	4.12.1 Retirer la tablette au-dessus du bac de fruits et légumes	261
4.1.1 Retirer le joint de porte	244	4.12.2 Monter la tablette au-dessus du bac de fruits et légumes	262
4.1.2 Monter le joint de porte.....	244	4.13 Remplacer le bac d'aliments congelés.....	263
4.2 Remplacer la poignée de porte.....	247	4.13.1 Retirer le bac d'aliments congelés	263
4.2.1 Retirer la poignée de porte	247	4.13.2 Monter le bac d'aliments congelés	263
4.2.2 Monter la poignée de porte	247	4.14 Remplacer la lampe LED supérieure	264
4.3 Remplacer la charnière supérieure de la porte	248	4.14.1 Retirer la lampe LED supérieure.....	264
4.3.1 Retirer la charnière supérieure de la porte	248	4.14.2 Monter la lampe LED supérieure	264
4.3.2 Monter la charnière supérieure de la porte.....	249	4.15 Remplacer la lampe LED latérale.....	265
4.4 Remplacer la charnière supérieure de la porte (porte avec afficheur).....	250	4.15.1 Retirer la lampe LED latérale	265
4.4.1 Retirer la charnière supérieure de la porte	251	4.15.2 Monter la lampe LED latérale	266
4.4.2 Monter la charnière supérieure de la porte.....	252	4.16 Remplacer la lampe LED du congélateur.....	268
4.5 Remplacer la charnière intermédiaire de la porte.....	253	4.16.1 Retirer la lampe LED du congélateur	268
4.5.1 Retirer la charnière intermédiaire de la porte	253	4.16.2 Monter la lampe LED du congélateur	268
4.5.2 Monter la charnière intermédiaire de la porte	254		
4.6 Remplacer la charnière de porte inférieure.....	255		
4.6.1 Retirer la charnière intermédiaire de la porte	255		
4.6.2 Monter la charnière de porte inférieure	255		
4.7 Remplacer la tablette.....	256		
4.7.1 Retirer la tablette.....	256		
4.7.2 Monter la tablette	256		

i A propos de ce document

1.1 Informations importantes

1.1.1 Objectif

Les conseils de réparation qui suivent visent à permettre au consommateur de réparer l'appareil par lui-même, conformément au règlement sur l'écoconception (en vigueur le 03/2021).

Ils contiennent des informations sur le remplacement de certaines pièces de rechange précises, y compris des mises en garde.

Pour toute question, veuillez contacter notre service après-vente. Notre responsabilité pour les dommages est conditionnelle à l'observation des conseils de réparation.

1.2 Explication des symboles

1.2.1 Niveaux de risque

Les niveaux de risque se composent d'un symbole et d'un terme d'avertissement. Le mot d'avertissement caractérise la gravité du danger.









Niveau de dangerosité	Signification
 DANGER	Le non respect de la consigne d'avertissement provoque la mort ou des blessures graves.
 AVERTISSEMENT	Le non respect de la consigne d'avertissement peut provoquer la mort ou des blessures graves.
 PRUDENCE	Le non respect de la consigne d'avertissement peut provoquer des blessures légères.
 ATTENTION !	Le non respect de la consigne d'avertissement peut provoquer des dégâts matériels.

Tableau 1: Niveaux de risque

1.2.2 Symboles de danger

Les symboles de danger sont des représentations figuratives renseignant sur la nature du danger.

Ce document utilise les symboles de danger suivants:

Symbole de danger	Signification
	Consigne d'avertissement générale
	Danger engendré par la tension électrique
	Risque d'explosion
	Risque de blessures par coupure

i A propos de ce document







Symbole de danger	Signification
	Risque de blessures par écrasement
	Danger engendré par des surfaces très chaudes
	Danger engendré par un champ magnétique puissant
	Danger engendré par un rayonnement non ionisant

Tableau 2: Symboles de danger

1.2.3 Structure des indications d'avertissement

Les consignes d'avertissement figurant dans ce document ont un aspect uniforme et une structure uniforme.

	<p> DANGER</p> <p>Type et source du danger ! Conséquences possibles en cas de non-respect du danger / de l'avertissement.</p> <ul style="list-style-type: none"> ▶ Mesures et interdictions pour éviter le danger.
--	---

L'exemple suivant montre une consigne d'avertissement mettant en garde contre le risque d'électrocution. La mesure permettant d'éviter le danger est nommée.

	<p> DANGER</p> <p>Risque d'électrocution par des pièces conductrices de tension ! Mort par électrocution.</p> <ul style="list-style-type: none"> ▶ Débrancher l'appareil du secteur minimum 60 secondes avant de démarrer la réparation.
--	---

1.2.4 Symboles généraux

Ce document utilise les symboles généraux suivants:







Symbole général	Signification
	Caractérisation d'une astuce particulière (texte et/ou graphique)
	Caractérisation d'une astuce simple (texte seul)
	Caractérisation d'un lien vers une vidéo
	Caractérisation d'outils nécessaires
	Caractérisation de conditions nécessaires
	Caractérisation d'une condition (si... , alors ...)
	Caractérisation d'un résultat
Start	Caractérisation d'une touche ou surface de commande
[00123456]	Caractérisation d'une référence de pièce
Statut	Caractérisation d'un texte affiché / fenêtre (sur l'afficheur)

Tableau 3: Symboles généraux

2.1 Consignes de sécurité générales

2.1.1 Tous les appareils électroménagers

Risque d'électrocution en raison de pièces sous tension!

- Des erreurs lors de réparations impliquant des composants électriques peuvent entraîner une décharge électrique!
- Débrancher l'appareil du secteur minimum 60 secondes avant de démarrer la réparation.
- Après la réparation, effectuer un test de sécurité selon VDE 0701 ou les réglementations spécifiques nationales.

Risque de blessures par coupure sur des bords tranchants!

- Porter des gants de protection.

Risque de casse durant la réparation, maintenance, dépannage et SAV en raison de composants lourds et mobiles

- Porter des chaussures de protection.
- Sécuriser les composants lourds contre le risque de chute.
- Ne pas coller les pièces du châssis sur les composants mobiles.

Risque lié à la sécurité / fonction de l'appareil!

- Utiliser uniquement des pièces détachées d'origine.

Risque d'endommagement des composants sensibles aux décharges électrostatiques!

- Ne pas toucher les modules, ni leur connexions et pistes conductrices.

Outils et aides

Désignation	Détails	Images
Embout Torx TX20 [00340865]	6,3 mm (1/4")	
Outil spécial [00342180]		

4.1 Remplacer le joint de porte

Pré-requis:

- ✔ La porte est ouverte.

4.1.1 Retirer le joint de porte

1. Sortir le joint de porte de la rainure dans les coins gauche et droit.

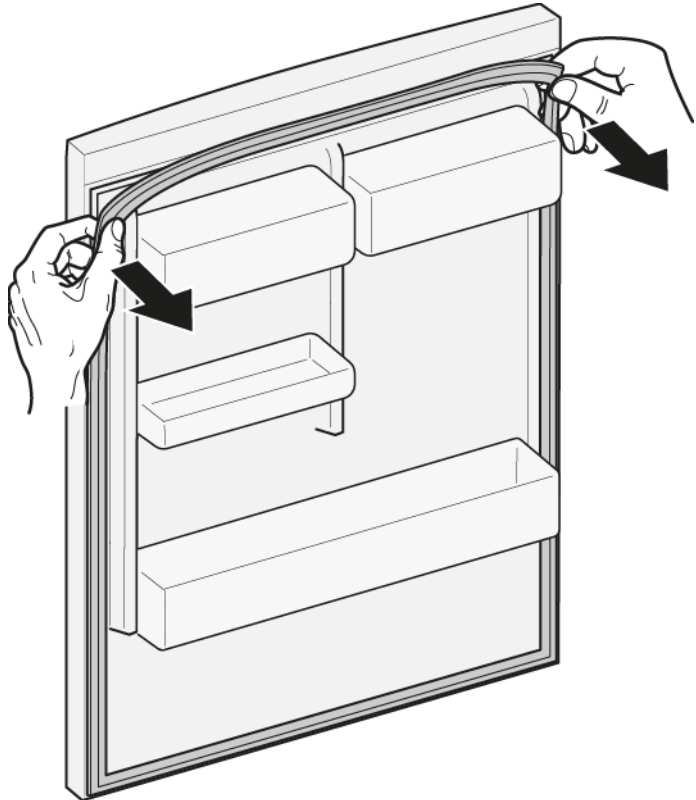

2. Retirer le joint de porte de la rainure.

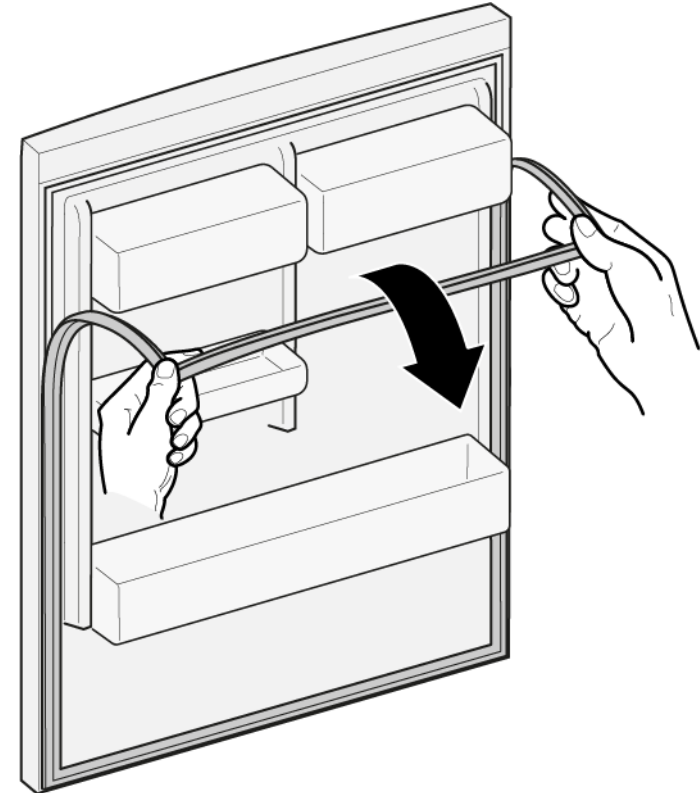

- ➡ Le joint de porte est retiré.

4.1.2 Monter le joint de porte



L'épaisseur du nouveau joint de porte peut différer légèrement de celle de l'ancien. Cela n'affectera en rien la fermeture ou le fonctionnement à long terme de la porte.

Si votre appareil est doté de charnière ou d'attaches de charnières ajustables, vous pourrez optimiser le comportement de fermeture par la suite. Les petits trous latéraux dans les joints de porte sont fonctionnels (nécessaires pour la ventilation). Il ne s'agit pas de défauts de production.

Réparation

1. S'assurer de l'absence de dégâts dans les rainures qui doivent accueillir le joint.

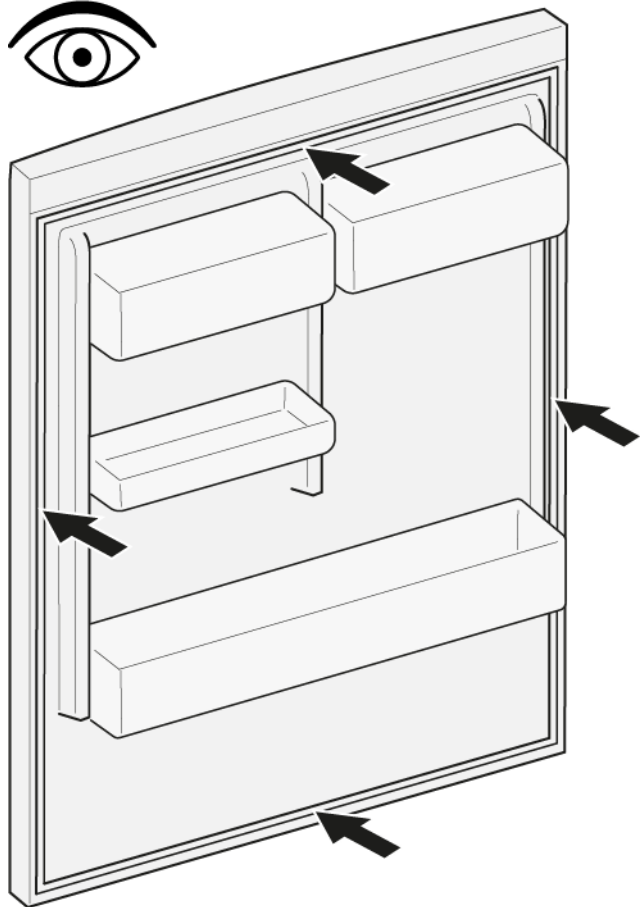

4. Pousser les coins du joint en haut et en bas dans la rainure.

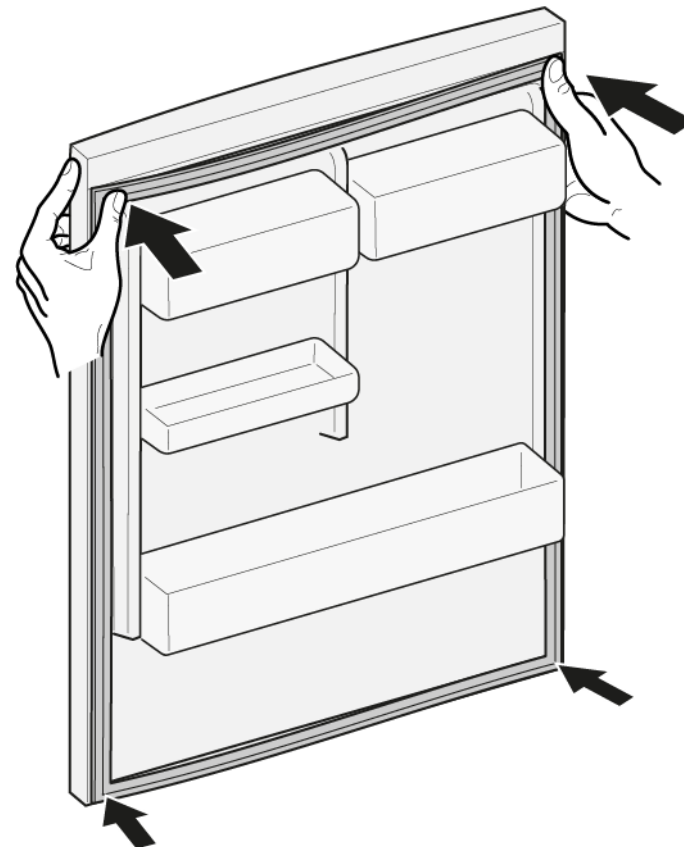

2.  Si la rainure de joint est endommagée.
- Contacter le service après-vente.

3.  Une légère déformation du joint est normale et ne saurait en affecter le fonctionnement. Il est recommandé de redresser le joint de porte avant de l'insérer dans l'appareil.

Réchauffer le joint de porte avec un sèche-cheveux ou de l'eau chaude et le reformer manuellement.

Réparation

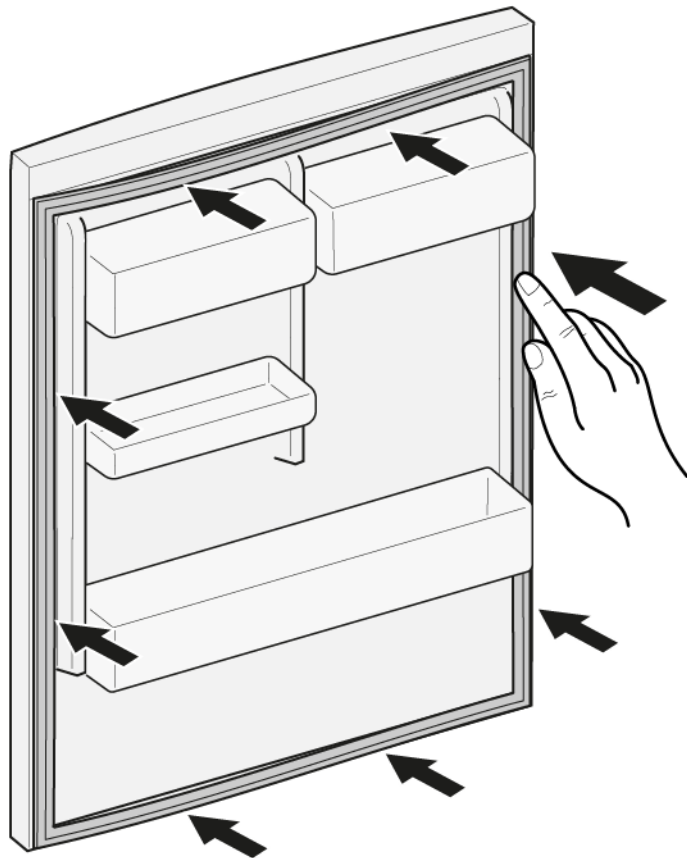

5. Enfoncer progressivement le joint dans la rainure.





-  Le joint de porte est installé.

4.2 Remplacer la poignée de porte

Outillage nécessaire:

-  Embout Torx TX20 6,3 mm (1/4") [00340865]
-  Tournevis plat Lame 10 mm x 1,6 mm x 200 mm

Pré-requis:

-  Appareil est déconnecté de l'alimentation.
-  La porte est ouverte.

4.2.1 Retirer la poignée de porte

- ▶ 1. Retirer deux capuchons de vis (1).
- ▶ 2. Dévisser deux vis (2).
- ▶ 3. Retirer la poignée de porte (3).

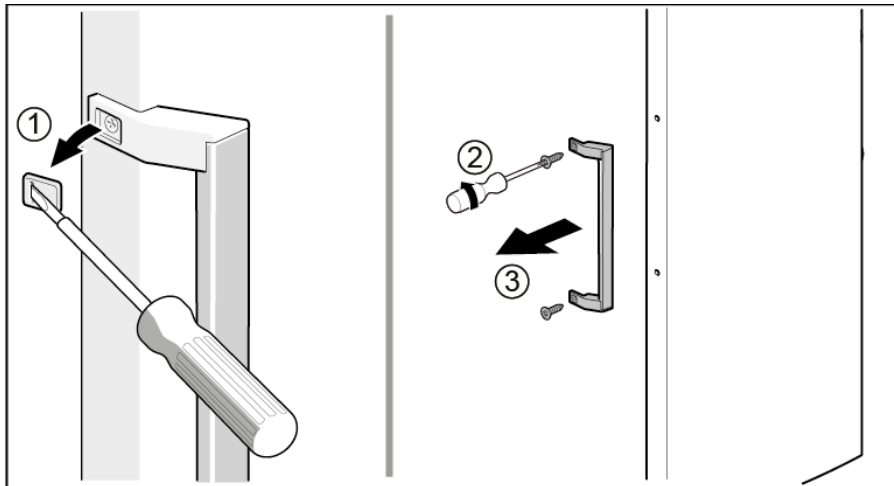

 La poignée de porte est retirée.



La poignée de la deuxième porte peut être retirée de la même manière.

4.2.2 Monter la poignée de porte

- ▶ Le montage s'effectue dans l'ordre chronologique inverse.

4.3 Remplacer la charnière supérieure de la porte

Outillage nécessaire:

🌀 Embout Torx TX20 6,3 mm (1/4") [00340865]

	⚠️ AVERTISSEMENT
Appareils lourds et volumineux ! Blessures dorsales et musculaires <ul style="list-style-type: none"> ▶ Seuls des spécialistes dûment formés devraient retirer la porte de l'appareil. ▶ Pour déplacer l'appareil, deux personnes sont nécessaires. ▶ Utiliser seulement des outils et de l'équipement appropriés. 	

	⚠️ PRUDENCE
Arêtes vives ! Blessures par coupure <ul style="list-style-type: none"> ▶ Porter des gants de protection. 	

	⚠️ AVERTISSEMENT
Chute d'appareils inclinés ! Fractures/blessures d'écrasement <ul style="list-style-type: none"> ▶ Sécuriser les appareils contre le risque de chute. 	

	⚠️ PRUDENCE
Risque de pièces qui chutent en raison de vis trop lâches ! Blessures dues à des pièces qui chutent. <ul style="list-style-type: none"> ▶ Sécuriser les composants contre le risque de chute. 	

	ATTENTION !
Risque de pièces qui chutent en raison de vis trop lâches ! Dommages à d'autres parties de l'appareil ou à la propriété du client, p. ex. au plancher. <ul style="list-style-type: none"> ▶ Sécuriser les composants contre le risque de chute. 	

Pré-requis:

- ✅ Appareil est déconnecté de l'alimentation.
- ✅ Les équipements intérieurs de l'appareil sont retirés.

4.3.1 Retirer la charnière supérieure de la porte

1. Glisser la pièce de support sous la base.

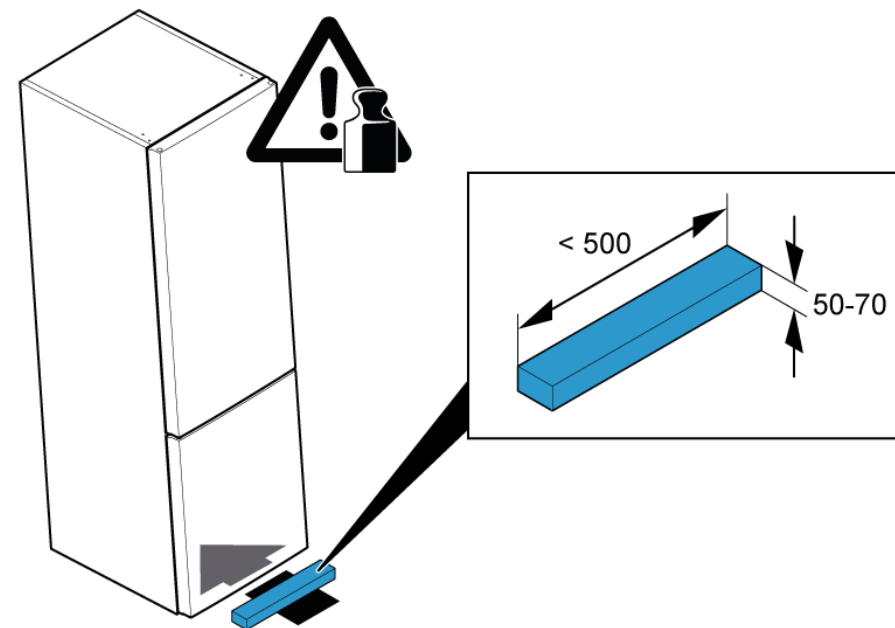

2. 1. Retirer le cache de la charnière supérieure (1).
2. Dévisser deux vis (2).
3. Retirer la charnière supérieure (3).

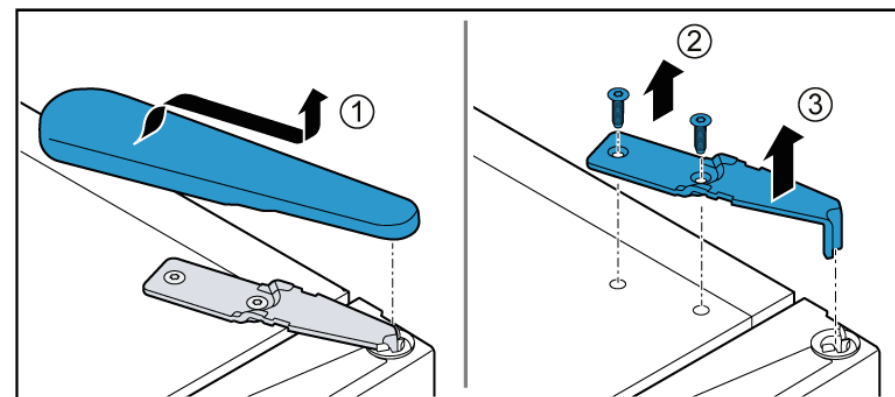

3. Retirer la porte supérieure.

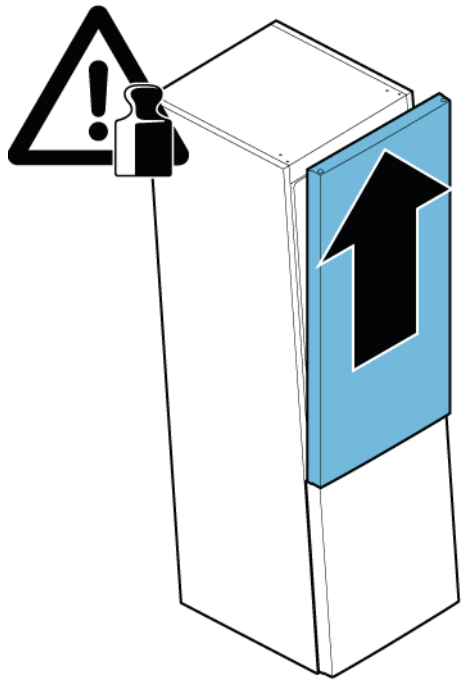

➡ La charnière supérieure est retirée.

4.3.2 Monter la charnière supérieure de la porte

▶ Le montage s'effectue dans l'ordre chronologique inverse.

4.4 Remplacer la charnière supérieure de la porte (porte avec afficheur)

Outillage nécessaire:

 Embout Torx TX20 6,3 mm (1/4") [00340865]

	⚠ AVERTISSEMENT
	<p>Appareils lourds et volumineux ! Blessures dorsales et musculaires</p> <ul style="list-style-type: none"> ▶ Seuls des spécialistes dûment formés devraient retirer la porte de l'appareil. ▶ Pour déplacer l'appareil, deux personnes sont nécessaires. ▶ Utiliser seulement des outils et de l'équipement appropriés.

	⚠ PRUDENCE
	<p>Arêtes vives ! Blessures par coupure</p> <ul style="list-style-type: none"> ▶ Porter des gants de protection.

	⚠ AVERTISSEMENT
	<p>Chute d'appareils inclinés ! Fractures/blessures d'écrasement</p> <ul style="list-style-type: none"> ▶ Sécuriser les appareils contre le risque de chute.



	⚠ PRUDENCE
	<p>Risque de pièces qui chutent en raison de vis trop lâches ! Blessures dues à des pièces qui chutent.</p> <ul style="list-style-type: none"> ▶ Sécuriser les composants contre le risque de chute.

	ATTENTION !
	<p>Risque de pièces qui chutent en raison de vis trop lâches ! Dommages à d'autres parties de l'appareil ou à la propriété du client, p. ex. au plancher.</p> <ul style="list-style-type: none"> ▶ Sécuriser les composants contre le risque de chute.

	⚠ DANGER
	<p>Risque d'électrocution en raison de pièces sous tension ! Risque d'électrocution en cas de réparation non conforme</p> <ul style="list-style-type: none"> ▶ Les pièces électriques doivent être réparées par des techniciens qualifiés. ▶ Après la réparation, effectuer un test de sécurité selon VDE 0701 ou les réglementations spécifiques nationales.

	⚠ DANGER
	<p>Risque d'électrocution par des pièces conductrices de tension ! Mort par électrocution.</p> <ul style="list-style-type: none"> ▶ Débrancher l'appareil du secteur minimum 60 secondes avant de démarrer la réparation.

Pré-requis:

-  Appareil est déconnecté de l'alimentation.
-  Les équipements intérieurs de l'appareil sont retirés.

4.4.1 Retirer la charnière supérieure de la porte

1. Glisser la pièce de support sous la base.

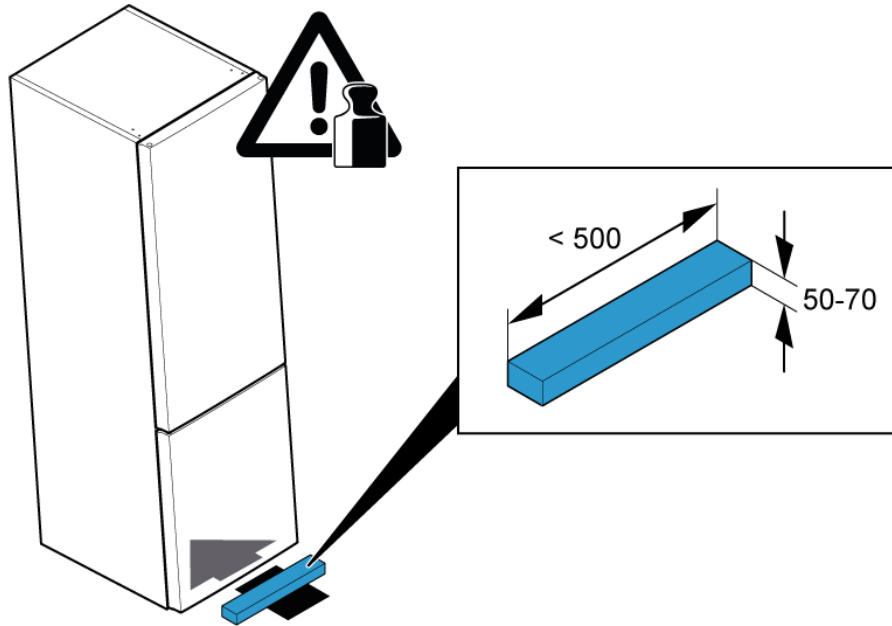

2. 1. Retirer le cache de la charnière supérieure (1).
2. Débrancher la connexion électrique (2).
3. Dévisser la vis de mise à la terre (3).

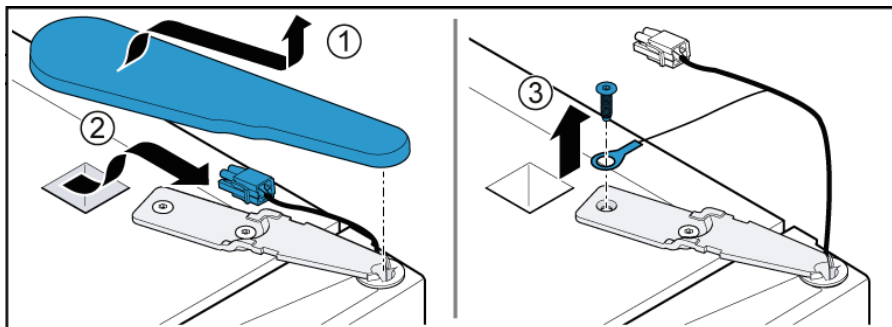

3. 1. Dévisser la vis (1).
2. Retirer la charnière supérieure (2).

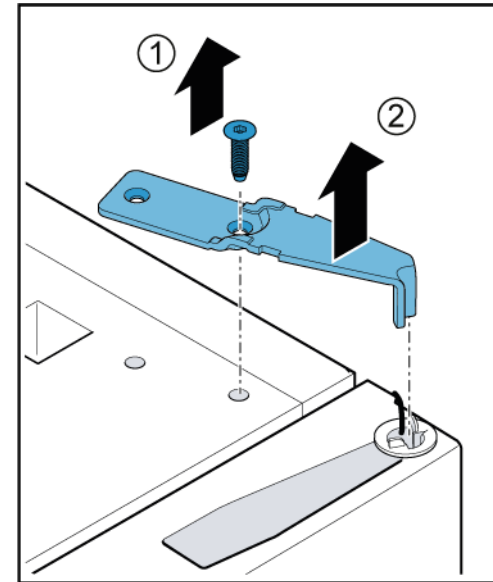

4. Retirer la porte supérieure.

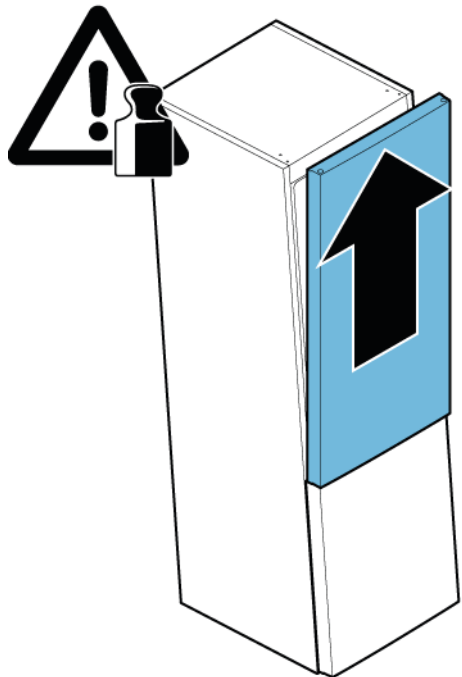

➡ La charnière supérieure est retirée.

4.4.2 Monter la charnière supérieure de la porte

- ▶ Le montage s'effectue dans l'ordre chronologique inverse.

4.5 Remplacer la charnière intermédiaire de la porte

Outillage nécessaire:

🌀 Embout Torx TX20 6,3 mm (1/4") [00340865]

	⚠️ AVERTISSEMENT Appareils lourds et volumineux ! Blessures dorsales et musculaires <ul style="list-style-type: none">▶ Seuls des spécialistes dûment formés devraient retirer la porte de l'appareil.▶ Pour déplacer l'appareil, deux personnes sont nécessaires.▶ Utiliser seulement des outils et de l'équipement appropriés.
--	--

	⚠️ PRUDENCE Arêtes vives ! Blessures par coupure <ul style="list-style-type: none">▶ Porter des gants de protection.
--	--

	⚠️ AVERTISSEMENT Chute d'appareils inclinés ! Fractures/blessures d'écrasement <ul style="list-style-type: none">▶ Sécuriser les appareils contre le risque de chute.
--	---

	⚠️ PRUDENCE Risque de pièces qui chutent en raison de vis trop lâches ! Blessures dues à des pièces qui chutent. <ul style="list-style-type: none">▶ Sécuriser les composants contre le risque de chute.
---	--

	⚠️ ATTENTION ! Risque de pièces qui chutent en raison de vis trop lâches ! Dommages à d'autres parties de l'appareil ou à la propriété du client, p. ex. au plancher. <ul style="list-style-type: none">▶ Sécuriser les composants contre le risque de chute.
--	---

Pré-requis:

- ✔ Appareil est déconnecté de l'alimentation.
- ✔ Les équipements intérieurs de l'appareil sont retirés.
- ✔ La charnière supérieure de la porte est retirée.

✔ La porte supérieure est retirée.

4.5.1 Retirer la charnière intermédiaire de la porte

1. Dévisser deux vis (1).
2. Retirer la charnière intermédiaire (2).

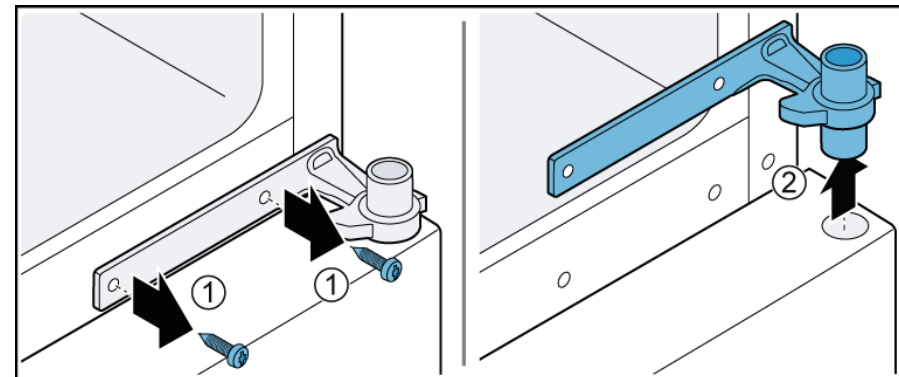

2. Retirer la porte inférieure.

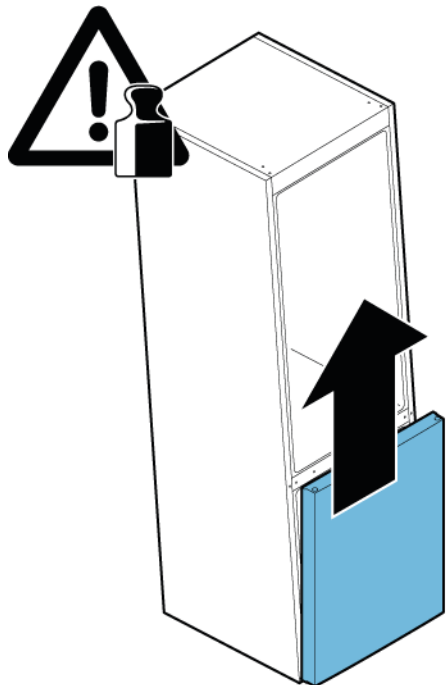

ⓘ La charnière intermédiaire est retirée.

4.5.2 Monter la charnière intermédiaire de la porte

- ▶ Le montage s'effectue dans l'ordre chronologique inverse.

4.6 Remplacer la charnière de porte inférieure

Outillage nécessaire:

🔧 Embout Torx TX20 6,3 mm (1/4") [00340865]

	⚠️ AVERTISSEMENT
Appareils lourds et volumineux ! Blessures dorsales et musculaires <ul style="list-style-type: none"> ▶ Seuls des spécialistes dûment formés devraient retirer la porte de l'appareil. ▶ Pour déplacer l'appareil, deux personnes sont nécessaires. ▶ Utiliser seulement des outils et de l'équipement appropriés. 	

	⚠️ PRUDENCE
Arêtes vives ! Blessures par coupure <ul style="list-style-type: none"> ▶ Porter des gants de protection. 	

	⚠️ AVERTISSEMENT
Chute d'appareils inclinés ! Fractures/blessures d'écrasement <ul style="list-style-type: none"> ▶ Sécuriser les appareils contre le risque de chute. 	

	⚠️ PRUDENCE
Risque de pièces qui chutent en raison de vis trop lâches ! Blessures dues à des pièces qui chutent. <ul style="list-style-type: none"> ▶ Sécuriser les composants contre le risque de chute. 	

	ATTENTION !
Risque de pièces qui chutent en raison de vis trop lâches ! Dommages à d'autres parties de l'appareil ou à la propriété du client, p. ex. au plancher. <ul style="list-style-type: none"> ▶ Sécuriser les composants contre le risque de chute. 	

Pré-requis:

- ✅ Appareil est déconnecté de l'alimentation.
- ✅ Les équipements intérieurs de l'appareil sont retirés.
- ✅ La charnière supérieure est retirée.

✅ La charnière intermédiaire est retirée.

4.6.1 Retirer la charnière intermédiaire de la porte

- ▶ 1. Dévisser deux vis (1).
- ▶ 2. Retirer la charnière inférieure (2).

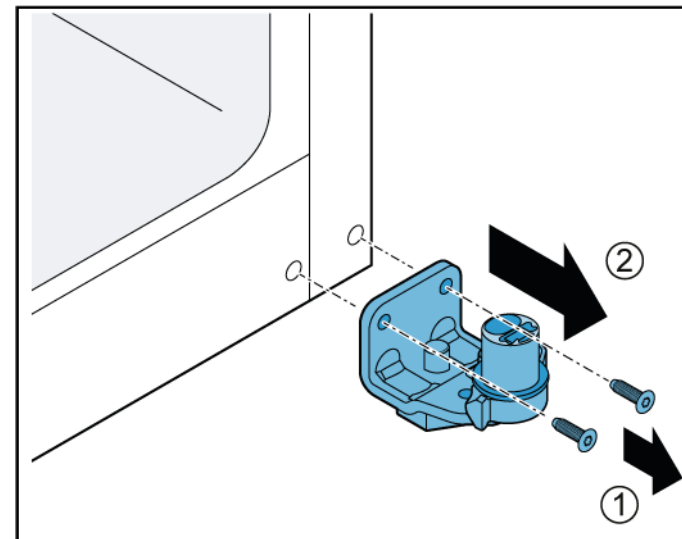

➡ La charnière inférieure de la porte est retirée.

4.6.2 Monter la charnière de porte inférieure

- ▶ Le montage s'effectue dans l'ordre chronologique inverse.

4.7 Remplacer la tablette

Pré-requis:

- ✔ La porte est ouverte.

4.7.1 Retirer la tablette

- ▶ 1. Soulever la tablette à l'arrière (1).
- ▶ 2. Soulever la tablette (2).

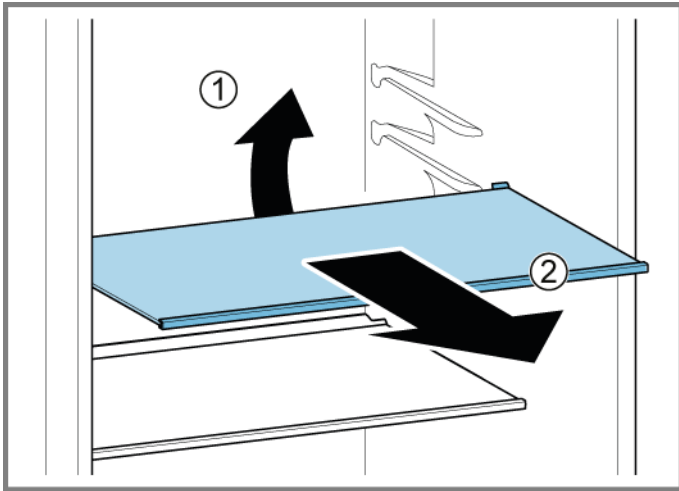

➡ La tablette est retirée.

4.7.2 Monter la tablette

- ▶ Le montage s'effectue dans l'ordre chronologique inverse.

4.8 Remplacer le casier à bouteilles

Pré-requis:

- ✔ La porte est ouverte.

4.8.1 Retirer le casier à bouteilles

- ▶ Extraire le casier à bouteilles.

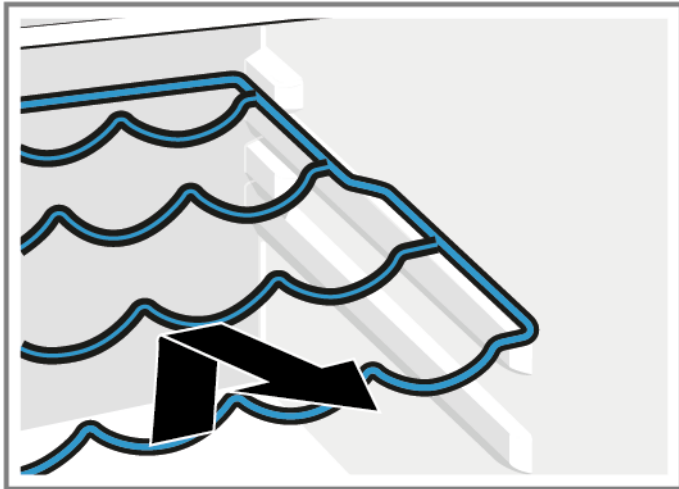

- ➡ Le casier à bouteilles est retiré.

4.8.2 Monter le casier à bouteilles

- ▶ Le montage s'effectue dans l'ordre chronologique inverse.

4.9 Remplacer l'étagère de la porte

Pré-requis:

- ✔ La porte est ouverte.

4.9.1 Retirer l'étagère de la porte

- ▶ Soulever l'étagère de la porte.

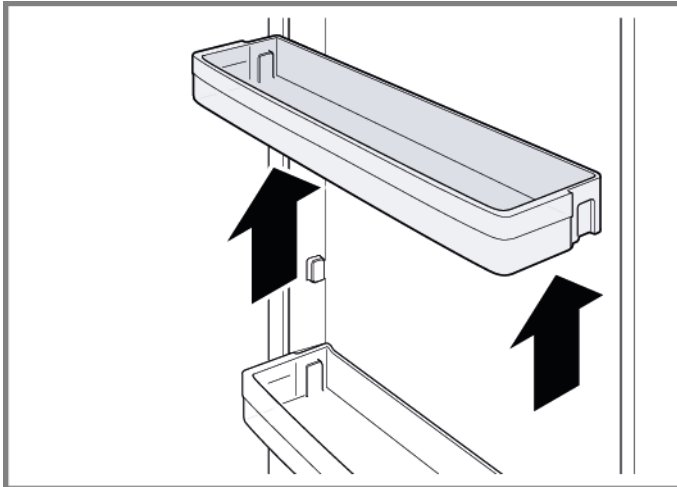

➡ L'étagère de la porte est retirée.

4.9.2 Monter l'étagère de la porte

- ▶ Le montage s'effectue dans l'ordre chronologique inverse.

4.10 Remplacer le bac de stockage

Pré-requis:

- ✔ La porte est ouverte.

4.10.1 Retirer le bac de stockage

1. Extraire complètement le bac de stockage.
2. 1. Soulever le bac de stockage par l'avant (1).
2. Retirer le bac (2).

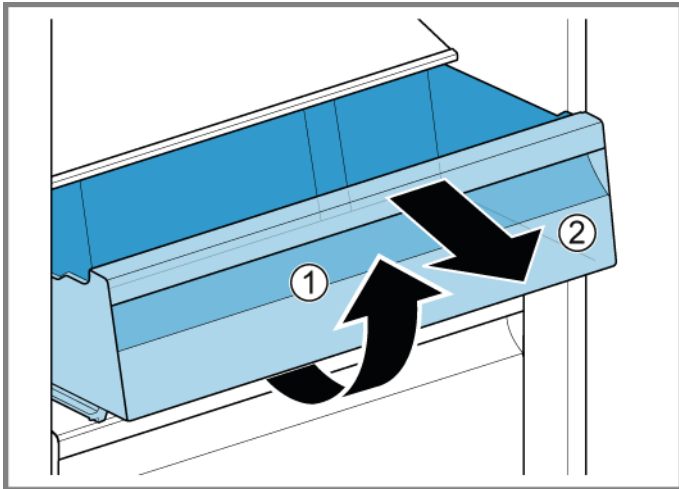

- ➡ Le bac de stockage est retiré.

4.10.2 Monter le bac de stockage

- ▶ Le montage s'effectue dans l'ordre chronologique inverse.

4.11 Remplacer le bac de fruits et légumes

Pré-requis:

- ✔ La porte est ouverte.

4.11.1 Retirer le bac de fruits et légumes

1. Extraire complètement le bac de stockage de fruits et légumes.
2. 1. Soulever le bac de fruits et légumes par l'avant (1).
2. Retirer le bac (2).

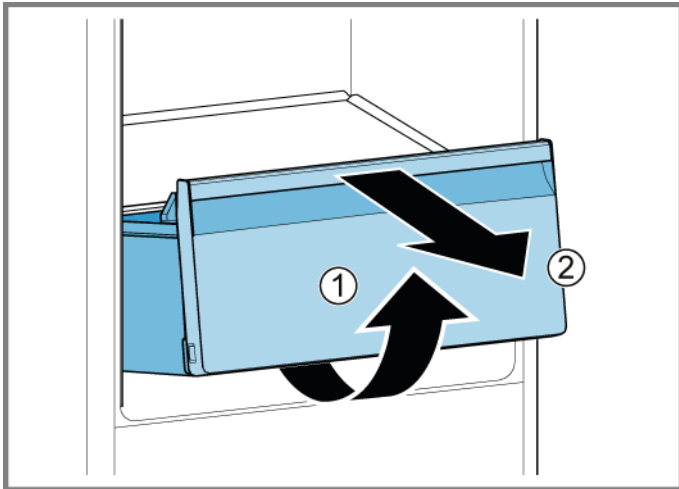

- ➡ Le bac de fruits et légumes est retiré.

4.11.2 Monter le bac de fruits et légumes

- ▶ Le montage s'effectue dans l'ordre chronologique inverse.

4.12 Remplacer la tablette au-dessus du bac de fruits et légumes

Pré-requis:

- ✓ La porte est ouverte.
- ✓ [Le bac de fruits et légumes est retiré. → 260](#)

4.12.1 Retirer la tablette au-dessus du bac de fruits et légumes

1. Pousser le cadre d'étanchéité vers le haut pour le sortir.

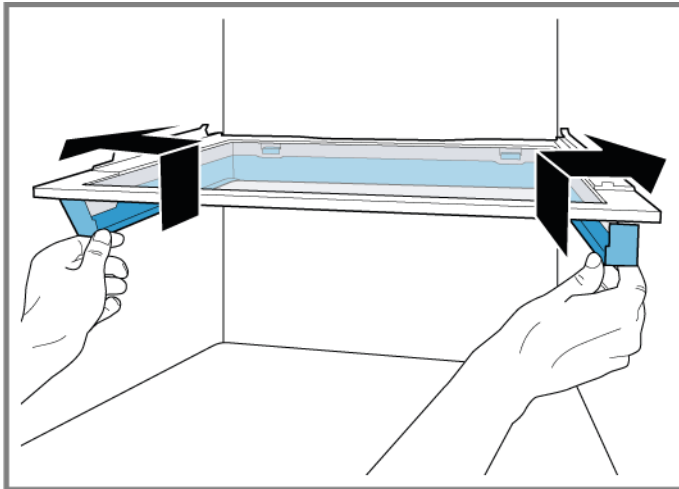

- ➡ Les crochets latéraux sont libérés.

2. Soulever le cadre d'étanchéité et le glisser vers l'arrière.

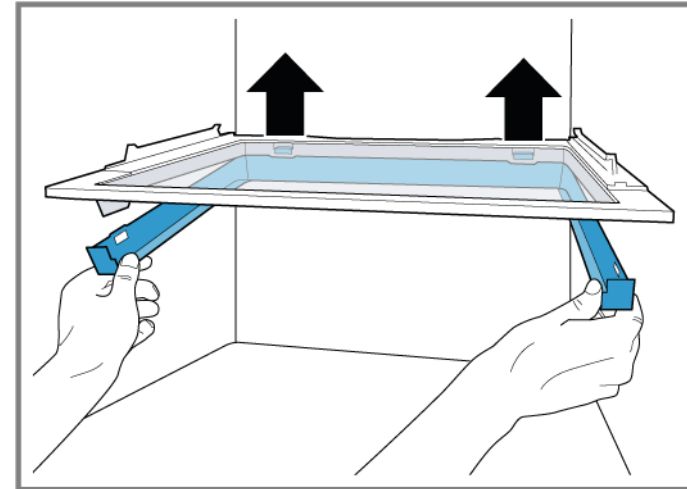

- ➡ Les crochets arrière sont libérés.

3. Retirer le cadre d'étanchéité.
4. Soulever la tablette au-dessus du bac de fruits et légumes et le faire pivoter sur le côté.

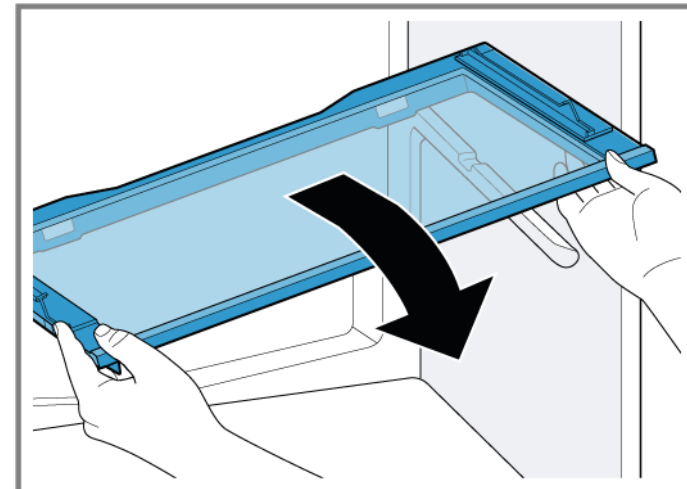

- ➡ La tablette au-dessus du bac de fruits et légumes est retirée.

4.12.2 Monter la tablette au-dessus du bac de fruits et légumes

- ▶ Le montage s'effectue dans l'ordre chronologique inverse.

4.13 Remplacer le bac d'aliments congelés

Pré-requis:

- ✔ La porte est ouverte.

4.13.1 Retirer le bac d'aliments congelés

- ▶ 1. Extraire complètement le bac d'aliments congelés (1).
- ▶ 2. Retirer le bac d'aliments (2).

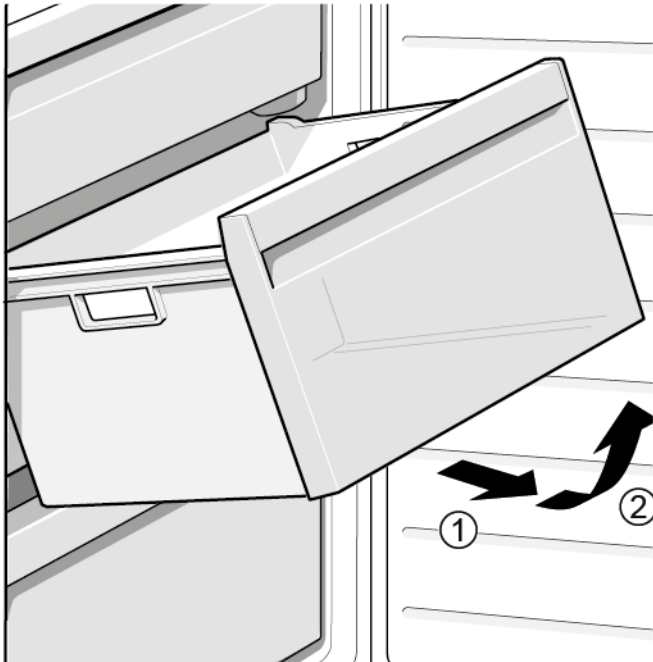

- ➡ Le bac d'aliments congelés est retiré.

4.13.2 Monter le bac d'aliments congelés

- ▶ Le montage s'effectue dans l'ordre chronologique inverse.

4.14 Remplacer la lampe LED supérieure

Outillage nécessaire:

🔧 Outil spécial [00342180]



Votre appareil comprend un éclairage LED sans maintenance.
Ces lampes peuvent être réparées exclusivement par le service après-vente ou un technicien autorisé !



⚠️ DANGER

Risque d'électrocution en raison de pièces sous tension !

Risque d'électrocution en cas de réparation non conforme

- ▶ Les pièces électriques doivent être réparées par des techniciens qualifiés.
- ▶ Après la réparation, effectuer un test de sécurité selon VDE 0701 ou les réglementations spécifiques nationales.



⚠️ DANGER

Risque d'électrocution par des pièces conductrices de tension !

Mort par électrocution.

- ▶ Débrancher l'appareil du secteur minimum 60 secondes avant de démarrer la réparation.



⚠️ PRUDENCE

Arêtes vives !

Blessures par coupure

- ▶ Porter des gants de protection.

Pré-requis:

- ✅ Appareil n'est pas sous tension.
- ✅ La porte est ouverte.

4.14.1 Retirer la lampe LED supérieure

1. Glisser l'outil de démontage entre la lampe LED supérieure et la couche intermédiaire du compartiment réfrigérateur pour libérer les crochets de la lampe (1).
2. Retirer la lampe LED supérieure (2).

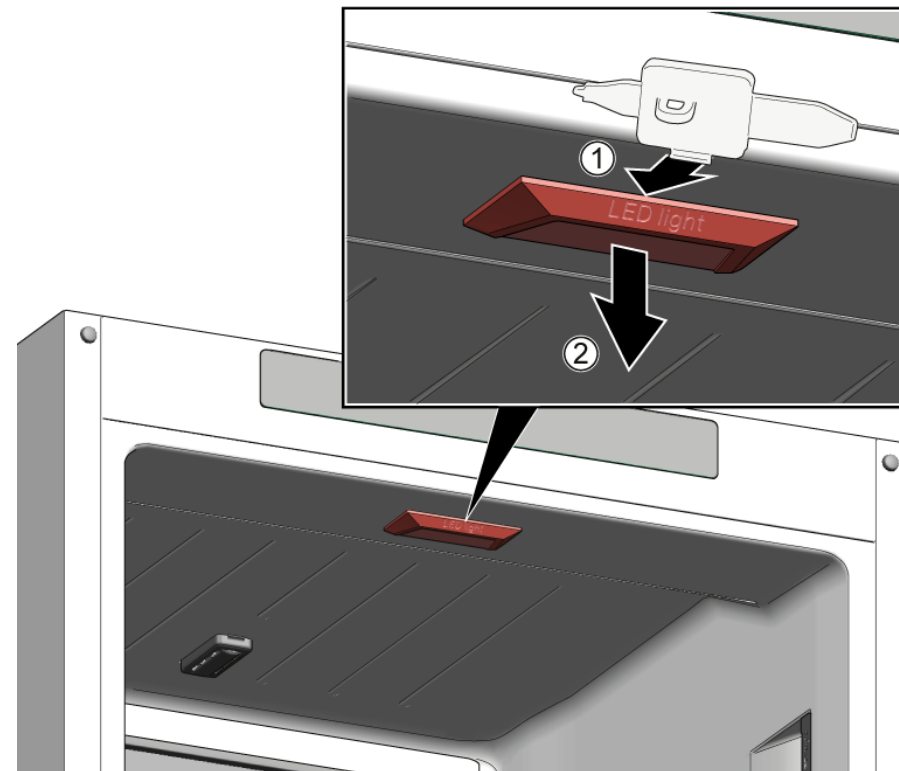

2. Débrancher la connexion électrique de la lampe LED supérieure.
- ➡ La lampe LED supérieure est retirée.

4.14.2 Monter la lampe LED supérieure

- ▶ Le montage s'effectue dans l'ordre chronologique inverse.

4.15 Remplacer la lampe LED latérale

Outillage nécessaire:

🔧 Outil spécial [00342180]



Votre appareil comprend un éclairage LED sans maintenance.
Ces lampes peuvent être réparées exclusivement par le service après-vente ou un technicien autorisé!



⚠️ DANGER

Risque d'électrocution en raison de pièces sous tension !

Risque d'électrocution en cas de réparation non conforme

- ▶ Les pièces électriques doivent être réparées par des techniciens qualifiés.
- ▶ Après la réparation, effectuer un test de sécurité selon VDE 0701 ou les réglementations spécifiques nationales.



⚠️ DANGER

Risque d'électrocution par des pièces conductrices de tension !

Mort par électrocution.

- ▶ Débrancher l'appareil du secteur minimum 60 secondes avant de démarrer la réparation.



⚠️ PRUDENCE

Arêtes vives !

Blessures par coupure

- ▶ Porter des gants de protection.



⚠️ ATTENTION !

Risque d'endommagement des composants sensibles aux décharges électrostatiques !

Domages aux composants

- ▶ Avant tout contact de ces composants, utiliser un système de protection électrostatique (ex. bracelet de mise à la terre).
- ▶ Ne pas toucher les connexions et pistes conductrices des modules.
- ▶ Utiliser pour le transport uniquement des matériaux conducteurs ou l'emballage d'origine.
- ▶ Éloigner les composants sensibles des matériaux électrostatiques (ex. plastique).

Pré-requis:

- ✓ Appareil n'est pas sous tension.
- ✓ La porte est ouverte.
- ✓ Les équipements intérieurs du réfrigérateur sont retirés.

4.15.1 Retirer la lampe LED latérale

1. Glisser l'outil de démontage entre le diffuseur et le boîtier de la lampe pour dégager le crochet (1).
2. Sortir le diffuseur de la lampe (2).
3. Dégager les crochets de fixation du diffuseur suivants de la même manière.

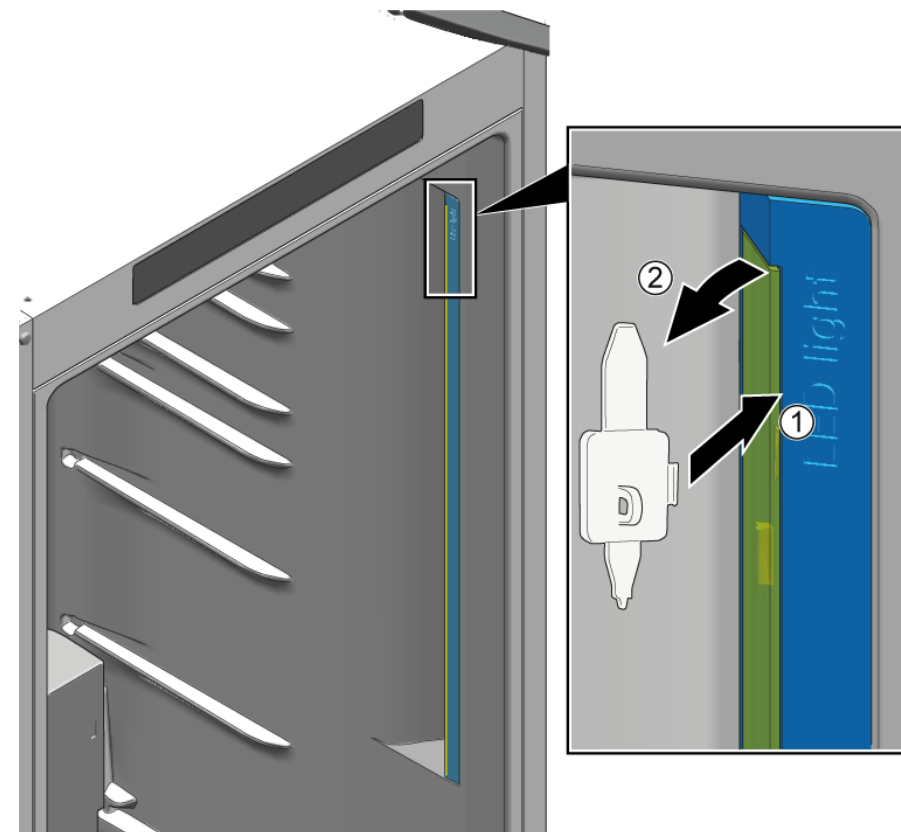

➡ Le diffuseur de la lampe est retiré.

Réparation

1. Appuyer sur le crochet de fixation du bandeau pour le dégager (1).
2. Relever l'outil de démontage avec le module LED d'environ 1 cm vers pour débrancher le module LED de la prise électrique (2).
3. Retirer le module LED (3).

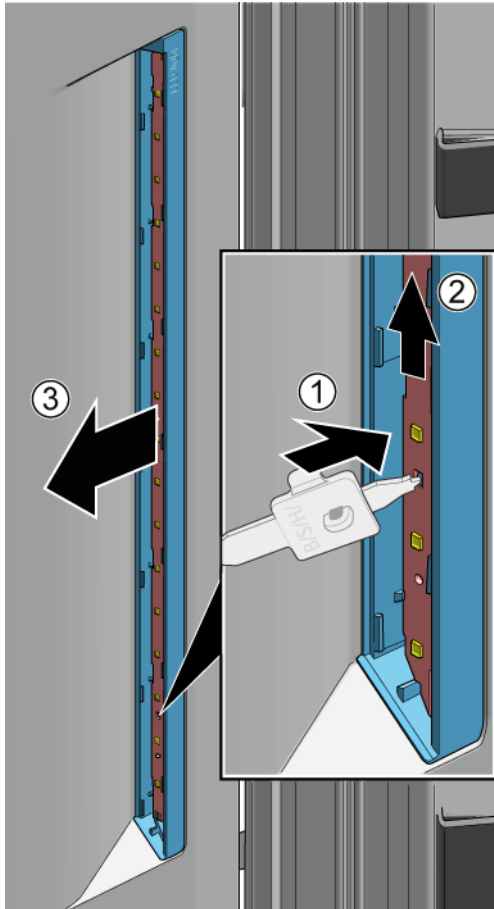

 La lampe LED latérale est retirée.

4.15.2 Monter la lampe LED latérale



Comme les crochets du diffuseur de la lampe cassent facilement durant le démontage, la lampe LED latérale SAV est un kit qui comprend le module LED et le diffuseur de la lampe.

1. Glisser l'outil de démontage entre le diffuseur et le boîtier de la lampe pour dégager le crochet (1).
2. Sortir le diffuseur de la lampe (2).
3. Dégager les crochets de fixation du diffuseur suivants de la même manière.

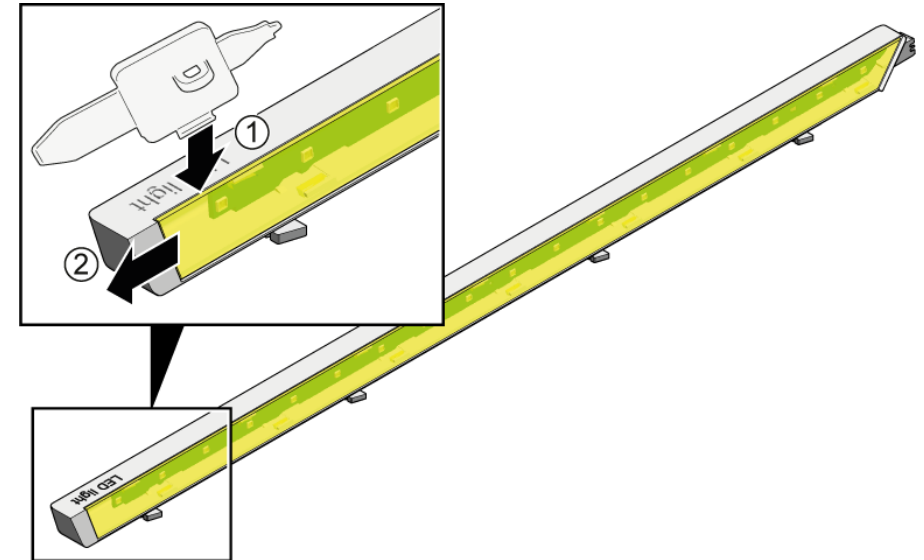

Réparation

2. 1. Appuyer sur le crochet de fixation du bandeau pour le dégager (1).
2. Sortir le module LED du boîtier en le faisant glisser vers le haut.
3. Pour des raisons de sécurité de transport de pièces détachées (3), mettre au rebut le boîtier du module LED utilisé.

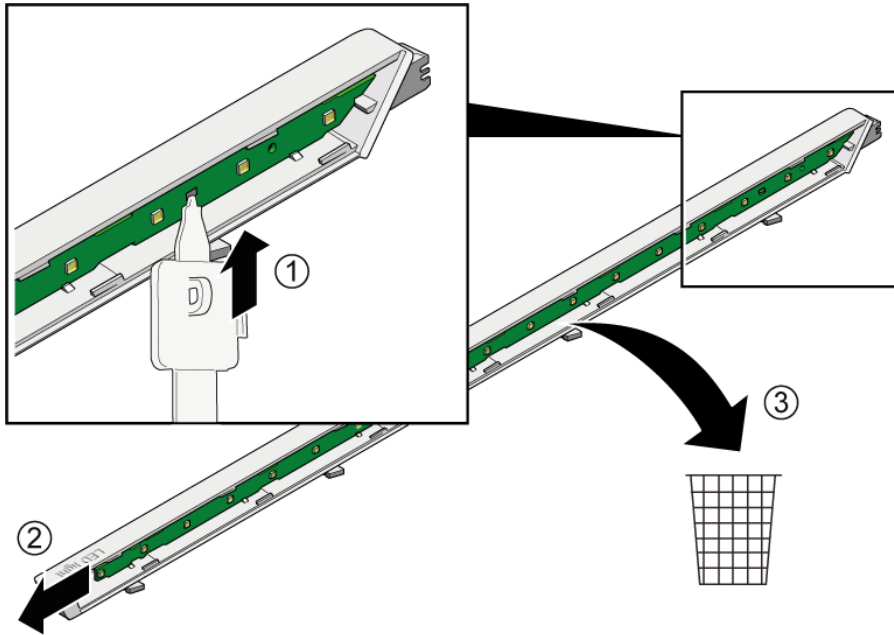

3. Installer le module LED et le diffuseur de la lampe dans l'ordre inverse du retrait.

4.16 Remplacer la lampe LED du congélateur

Outillage nécessaire:

🔧 Outil spécial [00342180]

i Votre appareil comprend un éclairage LED sans maintenance. Ces lampes peuvent être réparées exclusivement par le service après-vente ou un technicien autorisé!

⚠️ DANGER
Risque d'électrocution en raison de pièces sous tension !
 Risque d'électrocution en cas de réparation non conforme

- ▶ Les pièces électriques doivent être réparées par des techniciens qualifiés.
- ▶ Après la réparation, effectuer un test de sécurité selon VDE 0701 ou les réglementations spécifiques nationales.

⚠️ DANGER
Risque d'électrocution par des pièces conductrices de tension !
 Mort par électrocution.

- ▶ Débrancher l'appareil du secteur minimum 60 secondes avant de démarrer la réparation.

⚠️ PRUDENCE
Arêtes vives !
 Blessures par coupure

- ▶ Porter des gants de protection.

Pré-requis:

- ✔ Appareil n'est pas sous tension.
- ✔ La porte est ouverte.

4.16.1 Retirer la lampe LED du congélateur

- ▶ 1. Glisser l'outil de démontage entre le diffuseur et le boîtier de la lampe sur le côté de la lampe pour créer un espace (1).
- ▶ 2. Glisser l'outil de démontage de l'autre côté du crochet de fixation de la lampe et le faire pivoter vers l'avant (2).
- ▶ 3. Retirer la lampe LED du congélateur (3).

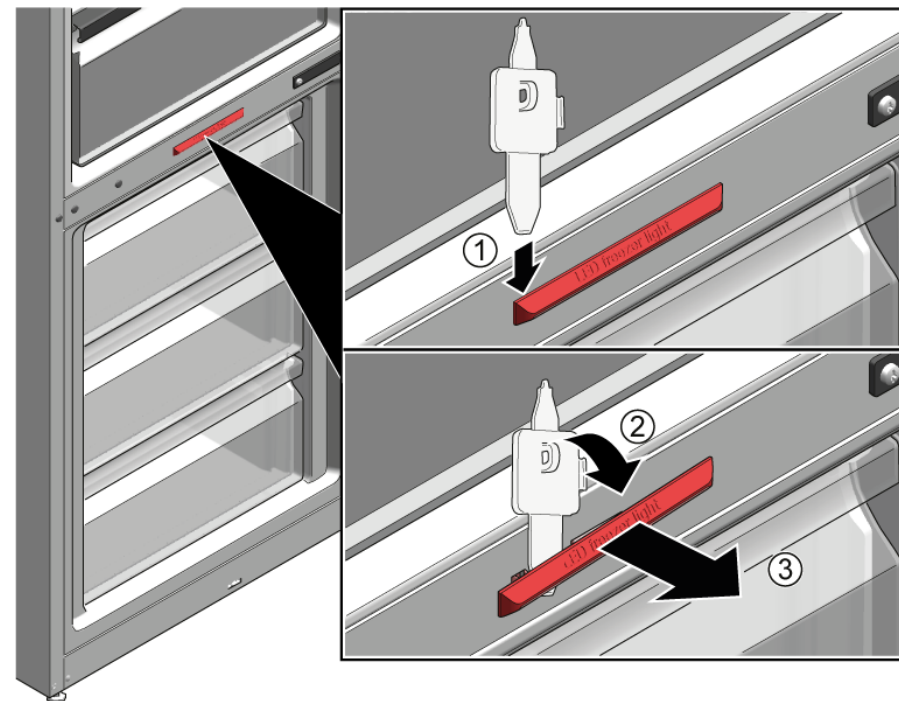





- ➡ La lampe LED du congélateur est débranchée.
- ➡ La lampe LED du congélateur est retirée.

4.16.2 Monter la lampe LED du congélateur

- ▶ Le montage s'effectue dans l'ordre chronologique inverse.

Reparatur Hinweise - Kühl- und Gefrierkombination

 Zu diesem Dokument	270	4.8 Austauschen der Flaschenablage	287
1.1 Wichtige Hinweise:	270	4.8.1 Ausbauen der Flaschenablage	287
1.1.1 Zweck	270	4.8.2 Einbauen der Flaschenablage	287
1.2 Zeichenerklärung.....	270	4.9 Austauschen des Türabstellers	288
1.2.1 Gefahrenstufen	270	4.9.1 Ausbauen des Türabstellers.....	288
1.2.2 Gefahrensymbole.....	270	4.9.2 Einbauen des Türabstellers.....	288
1.2.3 Struktur der Warnhinweise.....	271	4.10 Austauschen des Lagerbehälters	289
1.2.4 Allgemeine Symbole	271	4.10.1 Ausbauen des Lagerbehälter	289
 Sicherheit	272	4.10.2 Einbauen des Lagerbehälters.....	289
2.1 Allgemeine Sicherheitshinweise	272	4.11 Austauschen des Obst- und Gemüsebehälters	290
2.1.1 Alle Hausgeräte	272	4.11.1 Ausbauen des Obst- und Gemüsebehälters	290
 Werkzeuge und Hilfsmittel	273	4.11.2 Einbauen des Obst- und Gemüsebehälters	290
 Instandsetzen	274	4.12 Austauschen der Ablage über dem Obst- und Gemüsebehälter	291
4.1 Austauschen der Türdichtung.....	274	4.12.1 Ausbauen der Ablage über dem Obst- und Gemüsebehälter	291
4.1.1 Ausbauen der Türdichtung.....	274	4.12.2 Einbauen der Ablage über dem Obst- und Gemüsebehälter	292
4.1.2 Einbauen der Türdichtung	274	4.13 Austauschen des Gefriergutbehälters.....	293
4.2 Austauschen des Türgriffs.....	277	4.13.1 Ausbauen des Gefriergutbehälters	293
4.2.1 Ausbauen des Türgriffs	277	4.13.2 Einbauen des Gefriergutbehälters	293
4.2.2 Einbauen des Türgriffs	277	4.14 Austauschen der oberen LED-Lampe.....	294
4.3 Austauschen des oberen Türscharniers	278	4.14.1 Ausbauen der oberen LED-Lampe	294
4.3.1 Ausbauen des oberen Türscharniers.....	278	4.14.2 Einbauen der oberen LED-Lampe	294
4.3.2 Einbauen des oberen Türscharniers.....	279	4.15 Austauschen der seitlichen LED-Lampe	295
4.4 Austauschen des oberen Türscharniers (Tür mit Anzeige)	280	4.15.1 Ausbauen der seitlichen LED-Lampe	295
4.4.1 Ausbauen des oberen Türscharniers.....	281	4.15.2 Einbauen der seitlichen LED-Lampe	296
4.4.2 Einbauen des oberen Türscharniers.....	282	4.16 Austauschen der Gefrierfach-LED-Lampe	298
4.5 Austauschen des mittleren Türscharniers.....	283	4.16.1 Ausbauen der Gefrierfach-LED-Lampe	298
4.5.1 Ausbauen des mittleren Türscharniers	283	4.16.2 Einbauen der Gefrierfach-LED-Lampe	298
4.5.2 Einbauen des mittleren Türscharniers	284		
4.6 Austauschen des unteren Türscharniers	285		
4.6.1 Ausbauen des unteren Türscharniers.....	285		
4.6.2 Einbauen des unteren Türscharniers.....	285		
4.7 Austauschen der Ablage	286		
4.7.1 Ausbauen der Ablage.....	286		
4.7.2 Einbauen der Ablage.....	286		

Zu diesem Dokument

1.1 Wichtige Hinweise:

1.1.1 Zweck

Diese Reparaturhinweise dienen zur Unterstützung des Kunden bei der selbständigen Geräte-Reparatur gemäß der entsprechenden Ökodesign-Richtlinie (ab 03/2021).

Sie enthalten Informationen zum Austausch bestimmter Ersatzteile sowie Warn- und Gefahrenhinweise.

Bitte wenden Sie sich in Zweifelsfällen an unseren Kundendienst. Bei nicht ordnungsgemäßer Befolgung der Reparaturhinweise ist die Schadenshaftung ausgeschlossen.

1.2 Zeichenerklärung

1.2.1 Gefahrenstufen

Die Gefahrenstufen bestehen aus einem Symbol und einem Signalwort. Das Signalwort kennzeichnet die Schwere der Gefahr.









Gefahrenstufe	Bedeutung
	Nichtbeachtung des Warnhinweises führt zu Tod oder schweren Verletzungen.
	Nichtbeachtung des Warnhinweises kann zu Tod oder schweren Verletzungen führen.
	Nichtbeachtung des Warnhinweises kann zu leichten Verletzungen führen.
	Nichtbeachtung des Warnhinweises kann zu Sachschäden führen.

Tabelle 1: Gefahrenstufen

1.2.2 Gefahrensymbole

Gefahrensymbole sind sinnbildliche Darstellungen, die einen Hinweis auf die Art der Gefahr geben.

In diesem Dokument werden folgende Gefahrensymbole verwendet:

Gefahrensymbol	Bedeutung
	Allgemeiner Warnhinweis
	Gefahr durch elektrische Spannung
	Gefahr durch Explosion
	Gefahr von Schnittverletzungen
	Gefahr von Quetschverletzungen

i Zu diesem Dokument





Gefahrensymbol	Bedeutung
	Gefahr durch heiße Oberflächen
	Gefahr durch starkes Magnetfeld
	Gefahr durch nicht ionisierende Strahlung

Tabelle 2: Gefahrensymbole

1.2.3 Struktur der Warnhinweise

Warnhinweise haben in diesem Dokument ein einheitliches Aussehen und eine einheitliche Struktur.



	<div style="background-color: red; color: white; padding: 2px; display: inline-block;">⚠ GEFAHR</div> <p>Art und Quelle der Gefahr! Mögliche Folgen bei Nichtbeachtung der Gefahr / des Warnhinweises.</p> <ul style="list-style-type: none"> ▶ Maßnahmen und Verbote zur Vermeidung der Gefahr.
--	---

Das folgende Beispiel zeigt einen Warnhinweis, der vor Stromschlaggefahr durch spannungsführende Teile warnt. Die Maßnahme zur Vermeidung der Gefahr wird genannt.

	<div style="background-color: red; color: white; padding: 2px; display: inline-block;">⚠ GEFAHR</div> <p>Stromschlaggefahr durch spannungsführende Teile! Tod durch Stromschlag</p> <ul style="list-style-type: none"> ▶ Gerät mindestens 60 Sekunden vor Reparaturbeginn vom Netz trennen.
--	--

1.2.4 Allgemeine Symbole

In diesem Dokument werden folgende allgemeine Symbole verwendet:

Allg. Symbol	Bedeutung
	Kennzeichnung eines besonderen (Text und/oder Grafik) Tipps
	Kennzeichnung eines einfachen (nur Text) Tipps

Allg. Symbol	Bedeutung
	Kennzeichnung eines Links zu einer Videoanleitung
	Kennzeichnung erforderlicher Werkzeuge
	Kennzeichnung erforderlicher Voraussetzungen
	Kennzeichnung einer Bedingung (Wenn ..., dann ...)
	Kennzeichnung eines Ergebnisses
[Start]	Kennzeichnung einer Taste oder Schaltfläche
[00123456]	Kennzeichnung einer Materialnummer
Status	Kennzeichnung eines angezeigten Textes / Fensters (im Gerätedisplay)

Tabelle 3: Allgemeine Symbole

2.1 Allgemeine Sicherheitshinweise

2.1.1 Alle Hausgeräte

Stromschlaggefahr durch spannungsführende Teile!

- Wenn elektrische Komponenten fehlerhaft repariert werden, besteht Stromschlaggefahr!
- Das Gerät mindestens 60 Sekunden vor Beginn der Arbeiten vom Netz trennen.
- Nach der Reparatur muss eine Sicherheitsprüfung nach VDE 0701 oder länderspezifischen Vorschriften durchgeführt werden.

Verletzungsgefahr durch scharfe Kanten!

- Schutzhandschuhe tragen.

Quetschgefahr während Reparatur-, Wartungs-, Fehlersuche- und Servicearbeiten durch schwere sich bewegende Bauteile

- Schutzhandschuhe tragen.
- Schwere Bauteile gegen Herabfallen sichern.
- Körperteile nicht in sich bewegende Bauteile stecken.

Gefährdung der Gerätesicherheit/-funktion!

- Ausschließlich Originalersatzteile verwenden.

Gefahr der Beschädigung elektrostatisch gefährdeter Bauteile (elektrostatische Entladungen)!

- Die Module, einschließlich ihrer Anschlüsse und Leiterbahnen, keinesfalls berühren.

Werkzeuge und Hilfsmittel

Bezeichnung	Details	Bilder
Torx-Bit TX20 [00340865]	6,3 mm (1/4")	
Spezialwerkzeug [00342180]		

4.1 Austauschen der Türdichtung

Voraussetzung:

- ✔ Die Tür ist offen.

4.1.1 Ausbauen der Türdichtung

1. Die Türdichtung aus der Kerbe in der rechten und linken Ecke lösen.

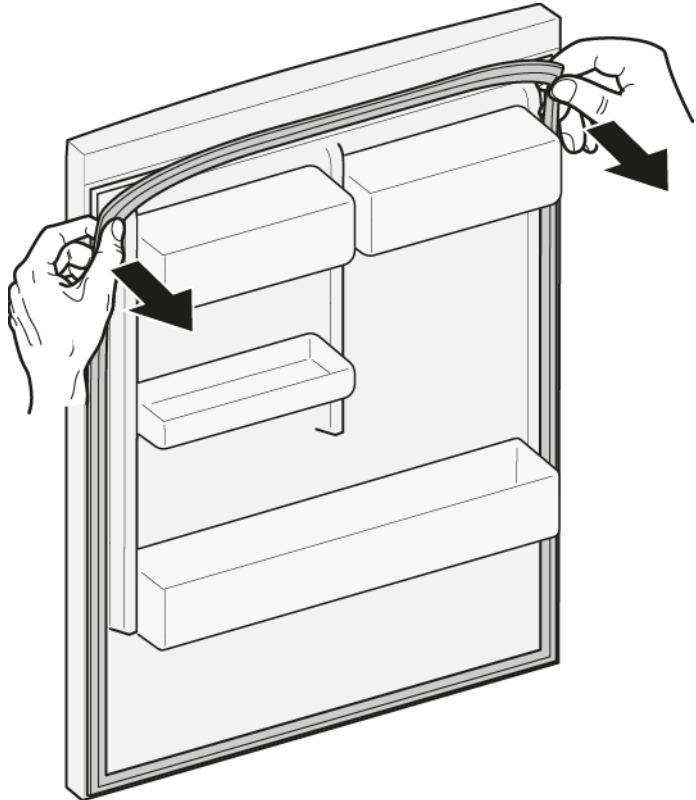

2. Die Türdichtung aus der Kerbe herausziehen.

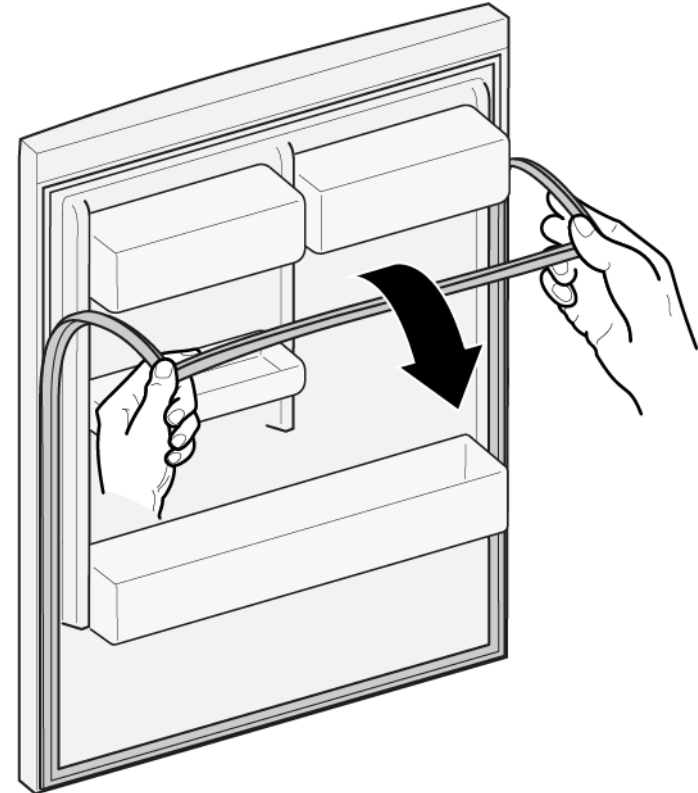

- ➡ Die Türdichtung ist entfernt.

4.1.2 Einbauen der Türdichtung



Die Dicke neuer Türdichtungen kann geringfügig von der Dicke alter Türdichtungen abweichen. Dies hat auf das Schließverhalten und die langfristige Funktion keinen Einfluss.

Wenn das Gerät mit einstellbaren Scharnieren oder Scharnierbefestigungen ausgestattet ist, kann das Schließverhalten anschließend optimiert werden.

Die kleinen seitlichen Löcher in der Türdichtung haben eine wichtige Funktion (für Lüftung erforderlich). Es handelt sich hierbei nicht um Produktionsfehler.

Instandsetzen

1. Die Dichtungskerbe auf Beschädigungen überprüfen.

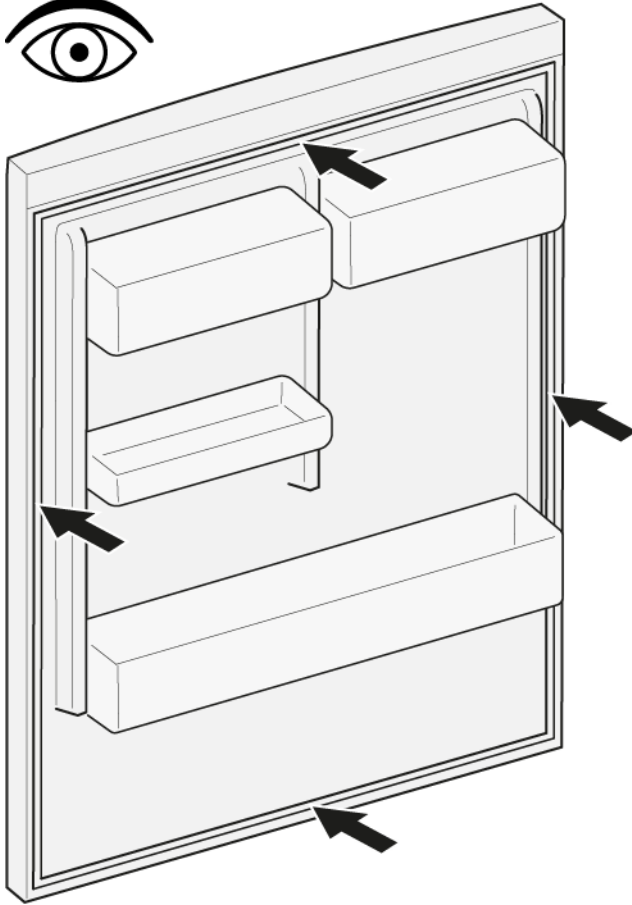

4. Die Dichtungsecken oben und unten in die Kerbe drücken.

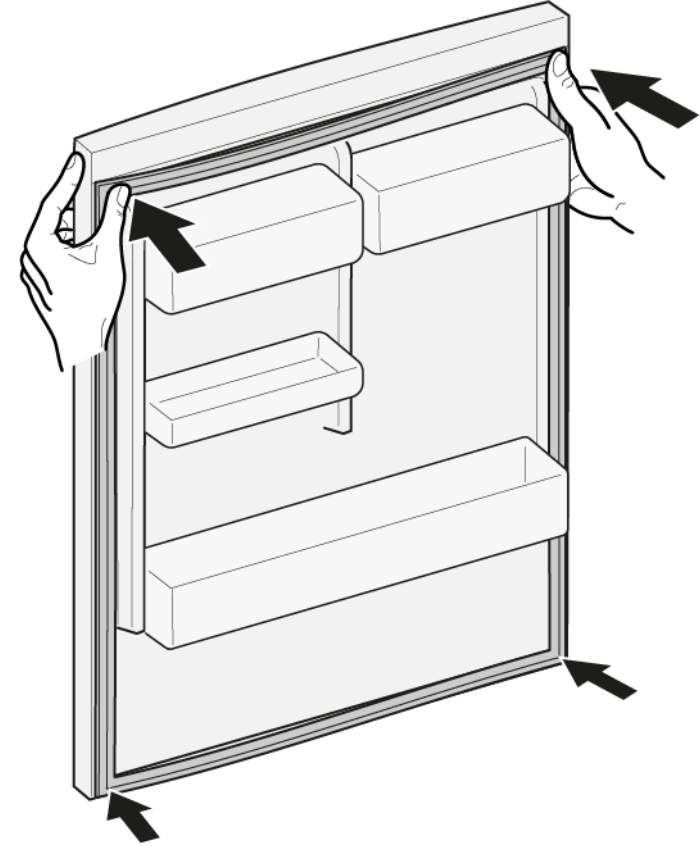

2.  Wenn die Dichtungskerbe beschädigt ist:
 - Den Kundendienst kontaktieren.

3.  Leichte Deformationen der Türdichtung sind normal und beeinträchtigen nicht die Funktion. Es wird empfohlen, die Türdichtung vor dem Einsetzen in das Gerät zu begradigen.

Die Türdichtung mit einem Haartrockner oder mit heißem Wasser erwärmen und von Hand in die richtige Form bringen.

Instandsetzen

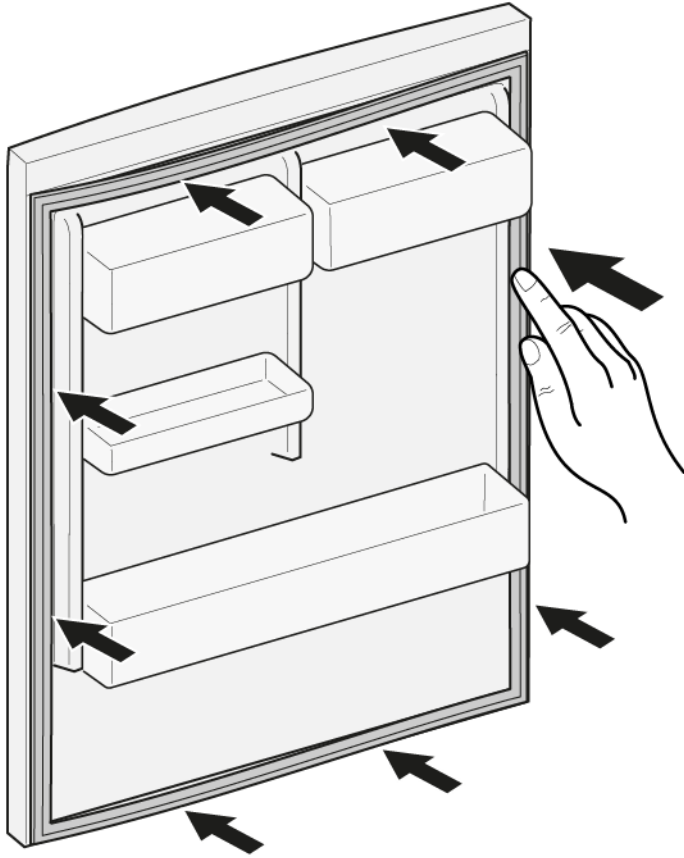

5. Die gesamte Dichtung Stück für Stück in die Kerbe drücken.





-  Die Türdichtung ist eingebaut.

4.2 Austauschen des Türgriffs

Spezielle Hilfsmittel:

-  Torx-Bit TX20 6,3 mm (1/4") [00340865]
-  Schlitzschraubendreher Klinge 10 mm x 1,6 mm x 200 mm

Voraussetzung:

-  Das Gerät ist spannungsfrei.
-  Die Tür ist offen.

4.2.1 Ausbauen des Türgriffs

- ▶ 1. Die beiden Schraubkappen entfernen (1).
- ▶ 2. Die beiden Schrauben herausschrauben (2).
- ▶ 3. Den Türgriff entfernen (3).

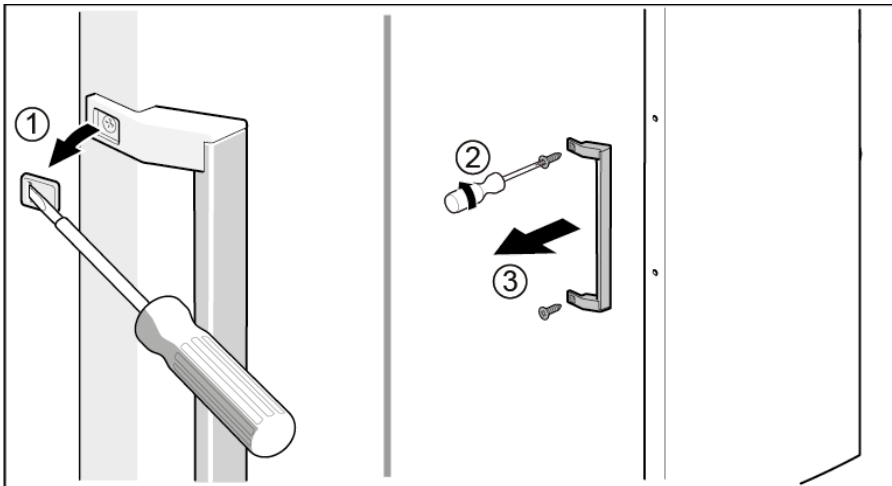

 Der Türgriff ist entfernt.



Der Türgriff für die zweite Tür kann auf die gleiche Art und Weise entfernt werden.

4.2.2 Einbauen des Türgriffs

- ▶ Der Einbau erfolgt in umgekehrter Reihenfolge.

4.3 Austauschen des oberen Türscharniers

Spezielle Hilfsmittel:

Torx-Bit TX20

6,3 mm (1/4")

[00340865]



⚠️ WARNUNG

Schwere, unhandliche Geräte!

Rücken- und Muskelverletzungen

- ▶ Der Ausbau der Gerätetür sollte nur von geschulten Spezialisten durchgeführt werden.
- ▶ Zum Bewegen des Geräts sind zwei Personen erforderlich.
- ▶ Nur geeignete Werkzeuge und Vorrichtungen verwenden.



⚠️ VORSICHT

Scharfe Kanten!

Schnittverletzungen

- ▶ Schutzhandschuhe tragen.



⚠️ WARNUNG

Wegrutschen des gekippten Geräts!

Knochenbrüche / Quetschungen

- ▶ Gerät gegen Wegrutschen sichern.



⚠️ VORSICHT

Risiko herabfallender Teile durch gelöste Schrauben!

Verletzungsgefahr durch herabfallende Teile.

- ▶ Die Komponenten gegen Herunterfallen sichern.



⚠️ ACHTUNG

Risiko herabfallender Teile durch gelöste Schrauben!

Gefahr der Beschädigung anderer Geräteteile bzw. von Beschädigungen im Haushalt des Kunden, z. B. des Bodens.

- ▶ Die Komponenten gegen Herunterfallen sichern.

Voraussetzung:

- ✔ Das Gerät ist spannungsfrei.
- ✔ Die Innenausstattungsteile des Geräts sind entfernt.

4.3.1 Ausbauen des oberen Türscharniers

1. Das Tragteil unter den Basisabschnitt schieben.

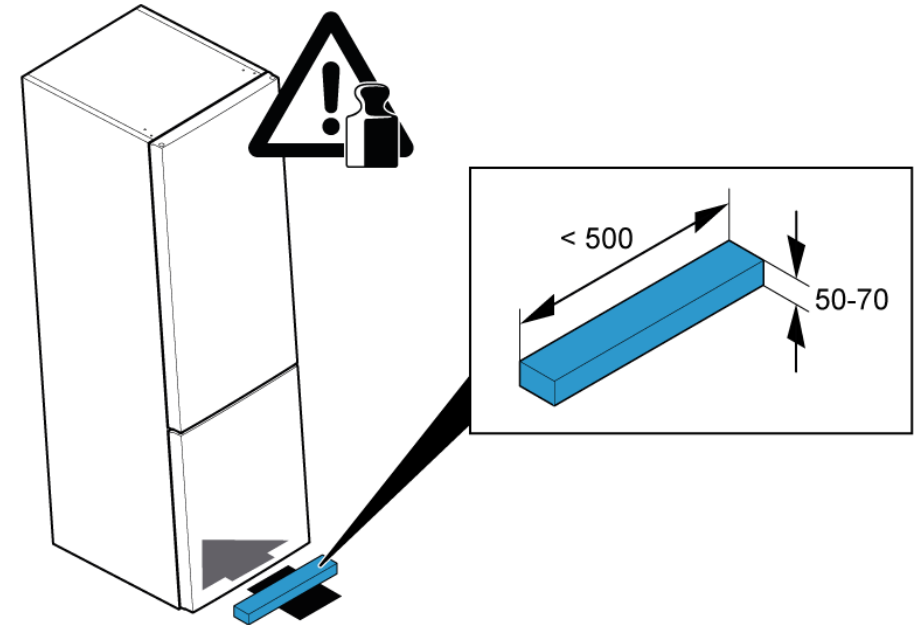

2. 1. Die obere Scharnierabdeckung entfernen (1).
2. Die beiden Schrauben heraus-schrauben (2).
3. Das obere Scharnier entfernen (3).

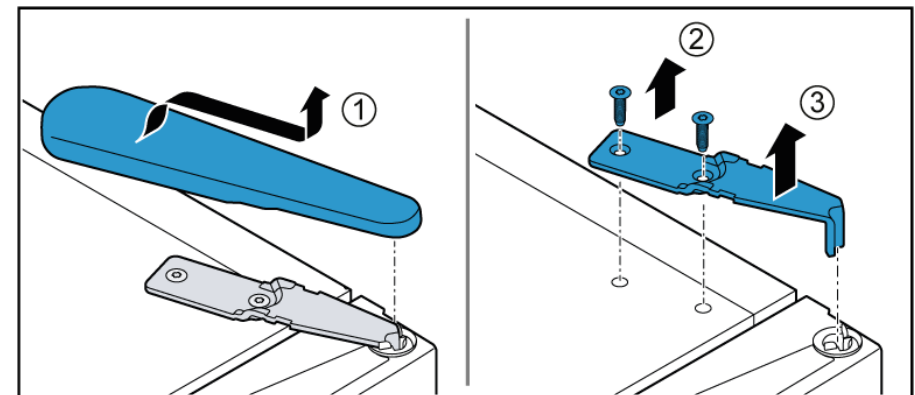

3. Die obere Tür entfernen.

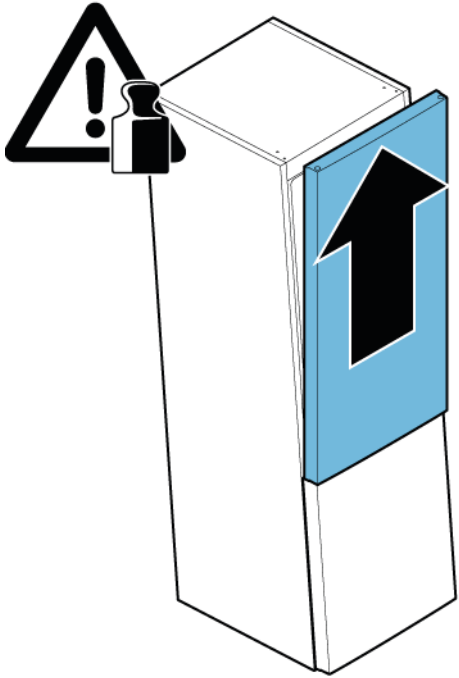

 Das obere Scharnier ist entfernt.

4.3.2 Einbauen des oberen Türscharniers

► Der Einbau erfolgt in umgekehrter Reihenfolge.

4.4 Austauschen des oberen Türscharniers (Tür mit Anzeige)

Spezielle Hilfsmittel:

 Torx-Bit TX20 6,3 mm (1/4") [00340865]

	⚠️ WARNUNG
	<p>Schwere, unhandliche Geräte! Rücken- und Muskelverletzungen</p> <ul style="list-style-type: none"> ▶ Der Ausbau der Gerätetür sollte nur von geschulten Spezialisten durchgeführt werden. ▶ Zum Bewegen des Geräts sind zwei Personen erforderlich. ▶ Nur geeignete Werkzeuge und Vorrichtungen verwenden.

	⚠️ VORSICHT
	<p>Scharfe Kanten! Schnittverletzungen</p> <ul style="list-style-type: none"> ▶ Schutzhandschuhe tragen.

	⚠️ WARNUNG
	<p>Wegrutschen des gekippten Gerätes! Knochenbrüche / Quetschungen</p> <ul style="list-style-type: none"> ▶ Gerät gegen Wegrutschen sichern.



	⚠️ VORSICHT
	<p>Risiko herabfallender Teile durch gelöste Schrauben! Verletzungsgefahr durch herabfallende Teile.</p> <ul style="list-style-type: none"> ▶ Die Komponenten gegen Herunterfallen sichern.

	ACHTUNG
	<p>Risiko herabfallender Teile durch gelöste Schrauben! Gefahr der Beschädigung anderer Geräteteile bzw. von Beschädigungen im Haushalt des Kunden, z. B. des Bodens.</p> <ul style="list-style-type: none"> ▶ Die Komponenten gegen Herunterfallen sichern.

	⚠️ GEFAHR
	<p>Stromschlaggefahr durch spannungsführende Teile! Lebensgefahr durch Stromschlag bei unsachgemäßer Reparatur</p> <ul style="list-style-type: none"> ▶ Elektroteile sollten von einer Elektrofachkraft repariert werden. ▶ Nach der Reparatur muss eine Sicherheitsprüfung nach VDE 0701 oder länderspezifischen Vorschriften durchgeführt werden.

	⚠️ GEFAHR
	<p>Stromschlaggefahr durch spannungsführende Teile! Tod durch Stromschlag</p> <ul style="list-style-type: none"> ▶ Gerät mindestens 60 Sekunden vor Reparaturbeginn vom Netz trennen.

Voraussetzung:

-  Das Gerät ist spannungsfrei.
-  Die Innenausstattungsteile des Geräts sind entfernt.

4.4.1 Ausbauen des oberen Türscharniers

1. Das Tragteil unter den Basisabschnitt schieben.

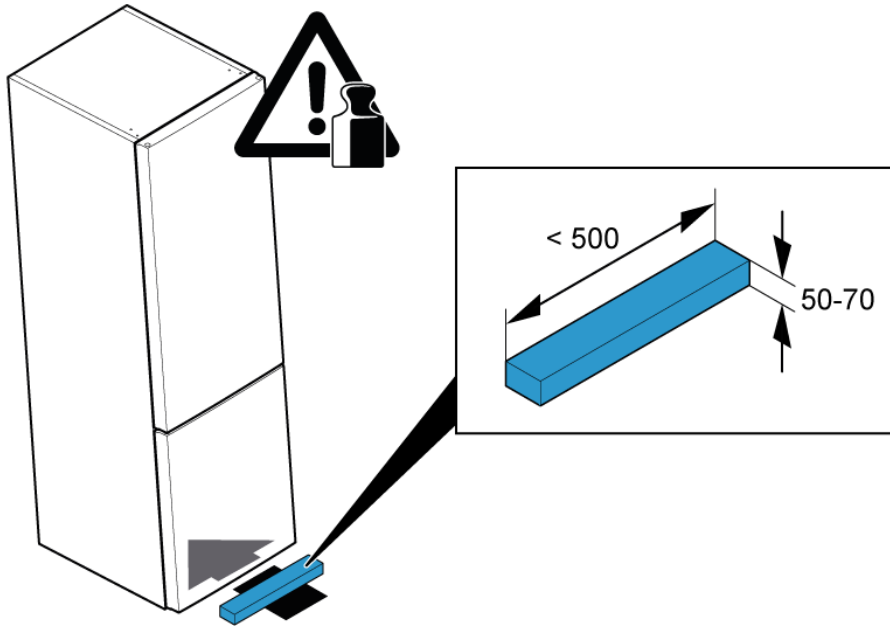

2. 1. Die obere Scharnierabdeckung entfernen (1).
2. Den elektrischen Anschluss trennen (2).
3. Die Erdanschlussschraube herausschrauben (3).

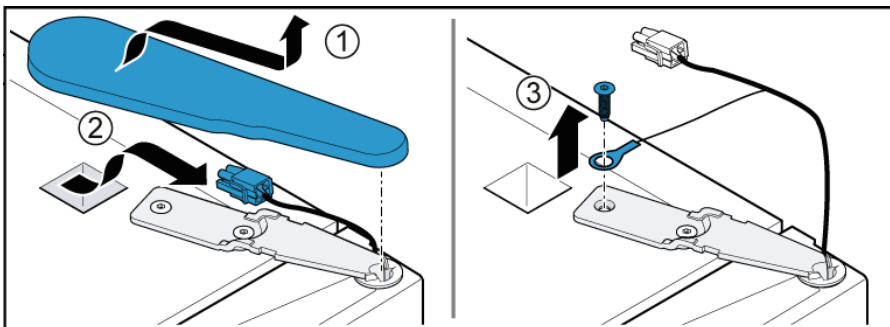

3. 1. Die Schraube herausschrauben (1).
2. Das obere Scharnier entfernen (2).

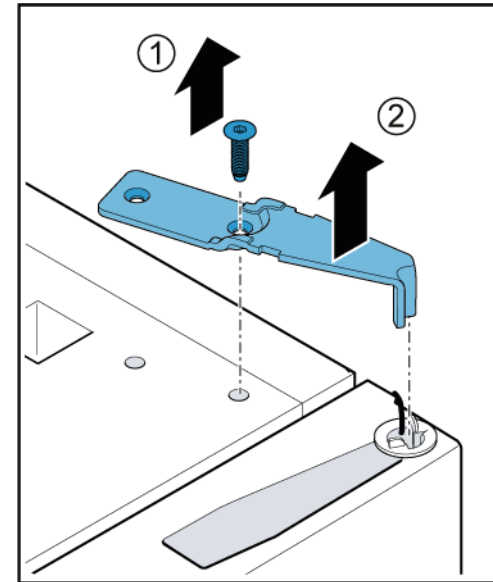

4. Die obere Tür entfernen.

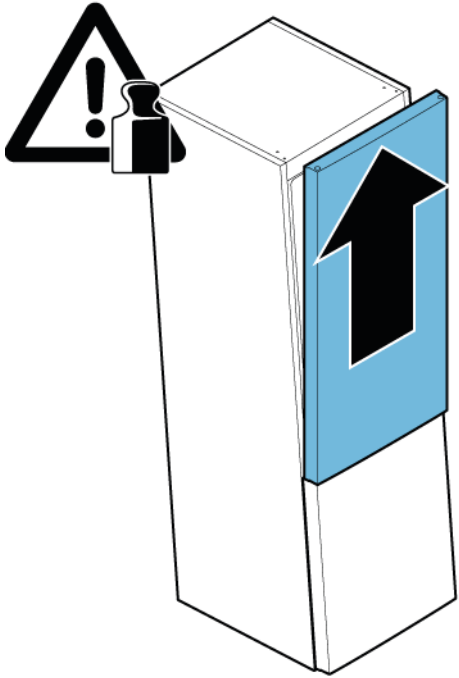

 Das obere Scharnier ist entfernt.

4.4.2 Einbauen des oberen Türscharniers

- ▶ Der Einbau erfolgt in umgekehrter Reihenfolge.

4.5 Austauschen des mittleren Türscharniers

Spezielle Hilfsmittel:

🔧 Torx-Bit TX20 6,3 mm (1/4") [00340865]

	<p style="text-align: center;">⚠️ WARNUNG</p> <p>Schwere, unhandliche Geräte! Rücken- und Muskelverletzungen</p> <ul style="list-style-type: none"> ▶ Der Ausbau der Gerätetür sollte nur von geschulten Spezialisten durchgeführt werden. ▶ Zum Bewegen des Geräts sind zwei Personen erforderlich. ▶ Nur geeignete Werkzeuge und Vorrichtungen verwenden.
	<p style="text-align: center;">⚠️ VORSICHT</p> <p>Scharfe Kanten! Schnittverletzungen</p> <ul style="list-style-type: none"> ▶ Schutzhandschuhe tragen.
	<p style="text-align: center;">⚠️ WARNUNG</p> <p>Wegrutschen des gekippten Geräts! Knochenbrüche / Quetschungen</p> <ul style="list-style-type: none"> ▶ Gerät gegen Wegrutschen sichern.
	<p style="text-align: center;">⚠️ VORSICHT</p> <p>Risiko herabfallender Teile durch gelöste Schrauben! Verletzungsgefahr durch herabfallende Teile.</p> <ul style="list-style-type: none"> ▶ Die Komponenten gegen Herunterfallen sichern.
	<p style="text-align: center;">⚠️ ACHTUNG</p> <p>Risiko herabfallender Teile durch gelöste Schrauben! Gefahr der Beschädigung anderer Geräteteile bzw. von Beschädigungen im Haushalt des Kunden, z. B. des Bodens.</p> <ul style="list-style-type: none"> ▶ Die Komponenten gegen Herunterfallen sichern.

Voraussetzung:

- ✅ Das Gerät ist spannungsfrei.
- ✅ Die Innenausstattungssteile des Geräts sind entfernt.
- ✅ Das obere Türscharnier ist entfernt.

✅ Die obere Tür ist entfernt.

4.5.1 Ausbauen des mittleren Türscharniers

1. Die beiden Schrauben herausschrauben (1).
2. Das mittlere Scharnier entfernen (2).

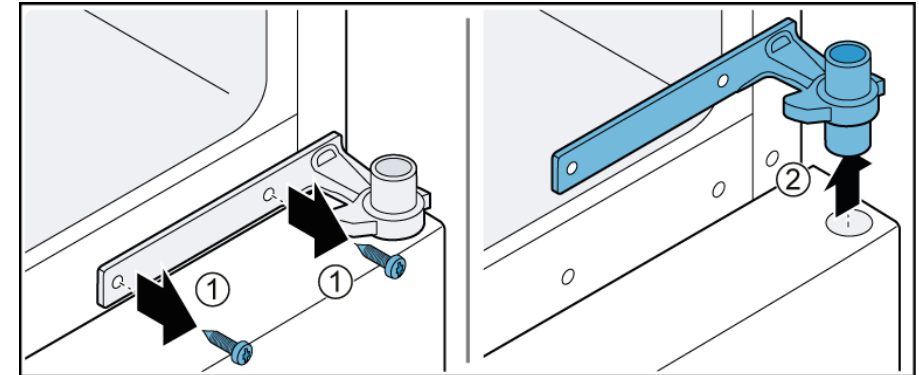

2. Die untere Tür entfernen.

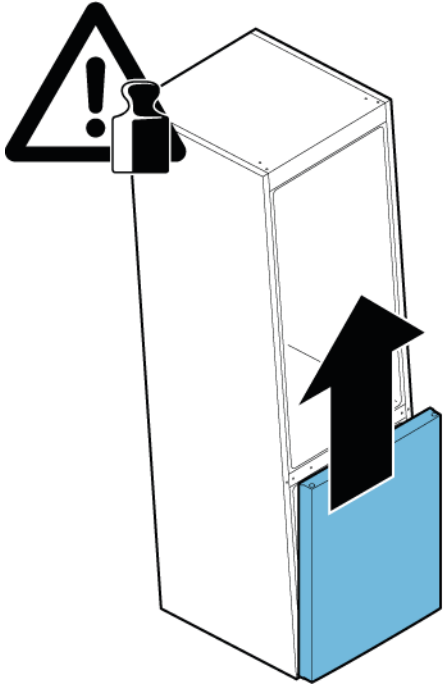

 Das mittlere Scharnier ist entfernt.

4.5.2 Einbauen des mittleren Türscharniers

- ▶ Der Einbau erfolgt in umgekehrter Reihenfolge.

4.6 Austauschen des unteren Türscharniers

Spezielle Hilfsmittel:

Torx-Bit TX20 6,3 mm (1/4") [00340865]

	<p style="text-align: center;">⚠️ WARNUNG</p> <p>Schwere, unhandliche Geräte! Rücken- und Muskelverletzungen</p> <ul style="list-style-type: none"> ▶ Der Ausbau der Gerätetür sollte nur von geschulten Spezialisten durchgeführt werden. ▶ Zum Bewegen des Geräts sind zwei Personen erforderlich. ▶ Nur geeignete Werkzeuge und Vorrichtungen verwenden.
	<p style="text-align: center;">⚠️ VORSICHT</p> <p>Scharfe Kanten! Schnittverletzungen</p> <ul style="list-style-type: none"> ▶ Schutzhandschuhe tragen.
	<p style="text-align: center;">⚠️ WARNUNG</p> <p>Wegrutschen des gekippten Gerätes! Knochenbrüche / Quetschungen</p> <ul style="list-style-type: none"> ▶ Gerät gegen Wegrutschen sichern.
	<p style="text-align: center;">⚠️ VORSICHT</p> <p>Risiko herabfallender Teile durch gelöste Schrauben! Verletzungsgefahr durch herabfallende Teile.</p> <ul style="list-style-type: none"> ▶ Die Komponenten gegen Herunterfallen sichern.
	<p style="text-align: center;">⚠️ ACHTUNG</p> <p>Risiko herabfallender Teile durch gelöste Schrauben! Gefahr der Beschädigung anderer Geräteteile bzw. von Beschädigungen im Haushalt des Kunden, z. B. des Bodens.</p> <ul style="list-style-type: none"> ▶ Die Komponenten gegen Herunterfallen sichern.

Voraussetzung:

- ✔ Das Gerät ist spannungsfrei.
- ✔ Die Innenausstattungsstücke des Geräts sind entfernt.
- ✔ Das obere Scharnier ist entfernt.

- ✔ Das mittlere Scharnier ist entfernt.

4.6.1 Ausbauen des unteren Türscharniers

- ▶ 1. Die beiden Schrauben herausschrauben (1).
- ▶ 2. Das untere Scharnier entfernen (2).

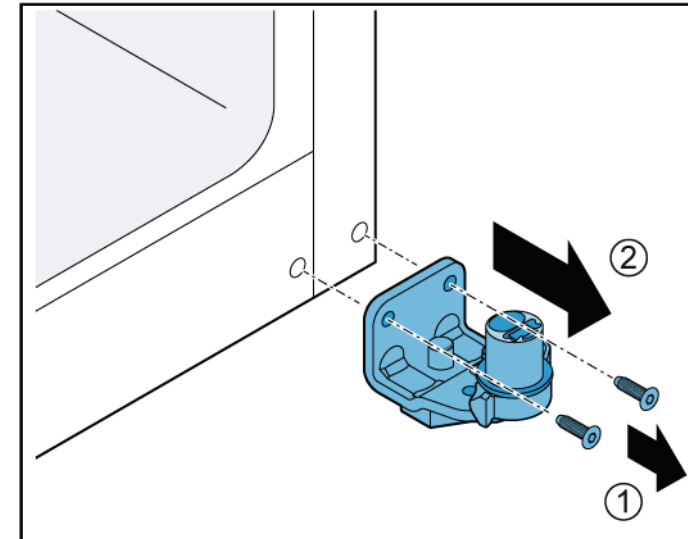

- ➡ Das untere Türscharnier ist entfernt.

4.6.2 Einbauen des unteren Türscharniers

- ▶ Der Einbau erfolgt in umgekehrter Reihenfolge.

4.7 Austauschen der Ablage

Voraussetzung:

- ✔ Die Tür ist offen.

4.7.1 Ausbauen der Ablage

- ▶ 1. Die Ablage hinten anheben (1).
- ▶ 2. Die Ablage lösen (2).

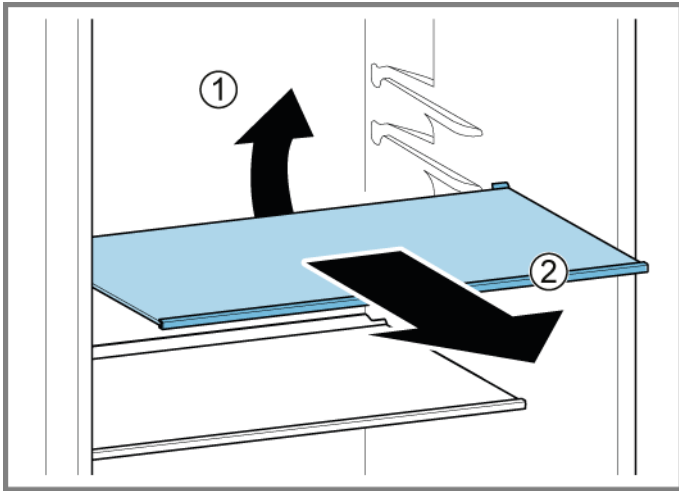

➡ Die Ablage ist entfernt.

4.7.2 Einbauen der Ablage

- ▶ Der Einbau erfolgt in umgekehrter Reihenfolge.

4.8 Austauschen der Flaschenablage

Voraussetzung:

- ✔ Die Tür ist offen.

4.8.1 Ausbauen der Flaschenablage

- ▶ Die Flaschenablage herausziehen.

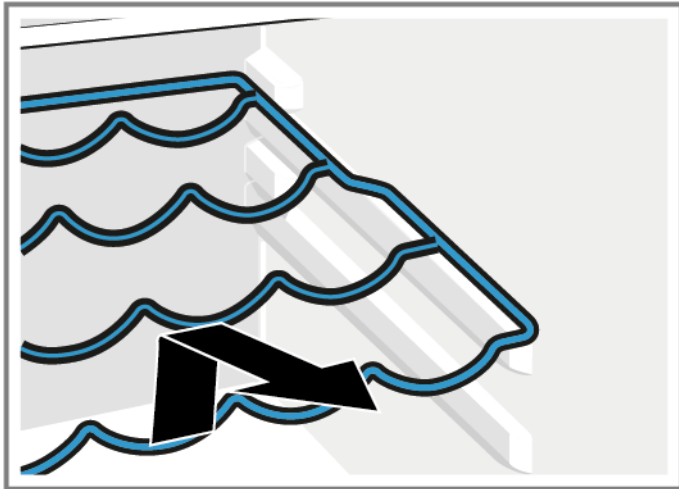

- ➡ Die Flaschenablage ist entfernt.

4.8.2 Einbauen der Flaschenablage

- ▶ Der Einbau erfolgt in umgekehrter Reihenfolge.

4.9 Austauschen des Türabstellers

Voraussetzung:

- ✔ Die Tür ist offen.

4.9.1 Ausbauen des Türabstellers

- ▶ Den Türabsteller anheben.

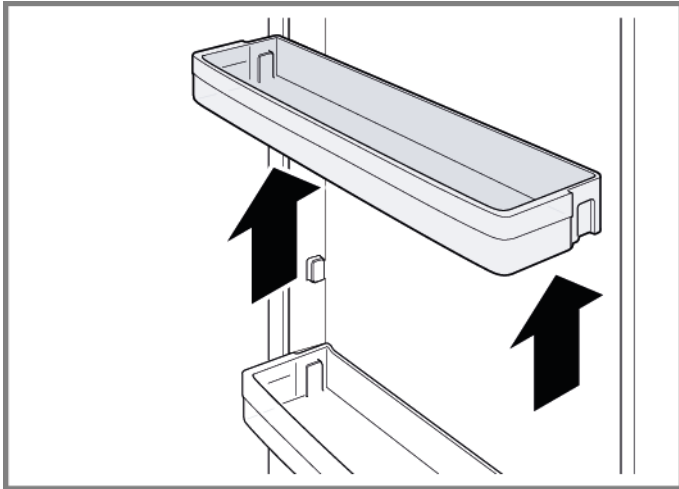

- ➡ Der Türabsteller ist entfernt.

4.9.2 Einbauen des Türabstellers

- ▶ Der Einbau erfolgt in umgekehrter Reihenfolge.

4.10 Austauschen des Lagerbehälters

Voraussetzung:

- ✔ Die Tür ist offen.

4.10.1 Ausbauen des Lagerbehälter

1. Den Lagerbehälter bis zum Anschlag herausziehen.
2. 1. Den Lagerbehälter vorn anheben (1).
2. Den Behälter entfernen (2).

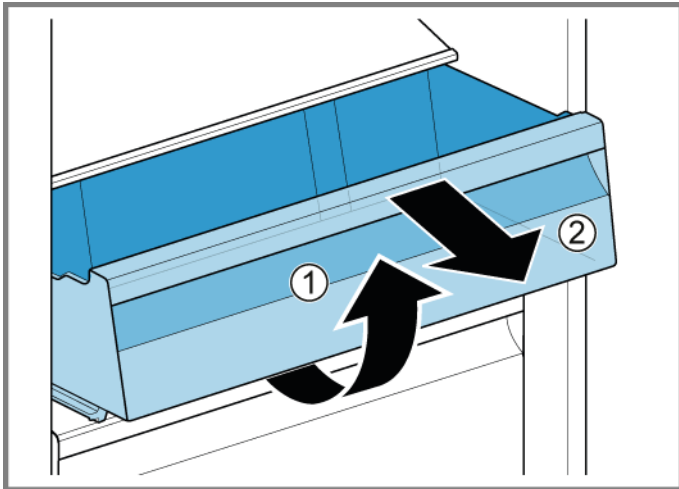

- ➔ Der Lagerbehälter ist entfernt.

4.10.2 Einbauen des Lagerbehälters

- ▶ Der Einbau erfolgt in umgekehrter Reihenfolge.

4.11 Austauschen des Obst- und Gemüsebehälters

Voraussetzung:

- ✔ Die Tür ist offen.

4.11.1 Ausbauen des Obst- und Gemüsebehälters

1. Den Obst- und Gemüsebehälter bis zum Anschlag herausziehen.
2. 1. Den Obst- und Gemüsebehälter vorn anheben (1).
2. Den Behälter entfernen (2).

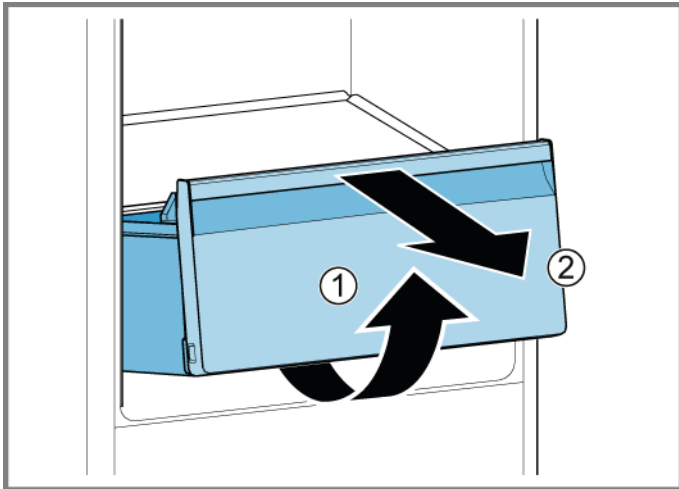

- ➡ Der Obst- und Gemüsebehälter ist entfernt.

4.11.2 Einbauen des Obst- und Gemüsebehälters

- ▶ Der Einbau erfolgt in umgekehrter Reihenfolge.

4.12 Austauschen der Ablage über dem Obst- und Gemüsebehälter

Voraussetzung:

- ✔ Die Tür ist offen.
- ✔ [Der Obst- und Gemüsebehälter ist entfernt.](#) → Seite 290

4.12.1 Ausbauen der Ablage über dem Obst- und Gemüsebehälter

1. Den Dichtungsrahmen nach oben außen drücken.

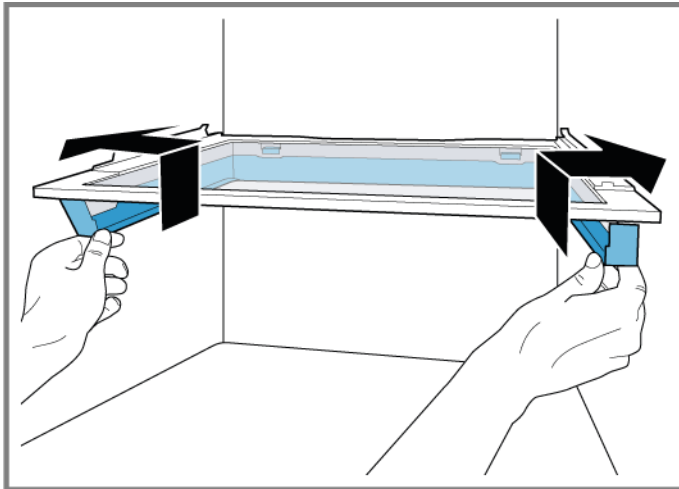

- ➡ Die Seitenhaken werden freigegeben.

2. Den Dichtungsrahmen anheben und nach hinten schieben.

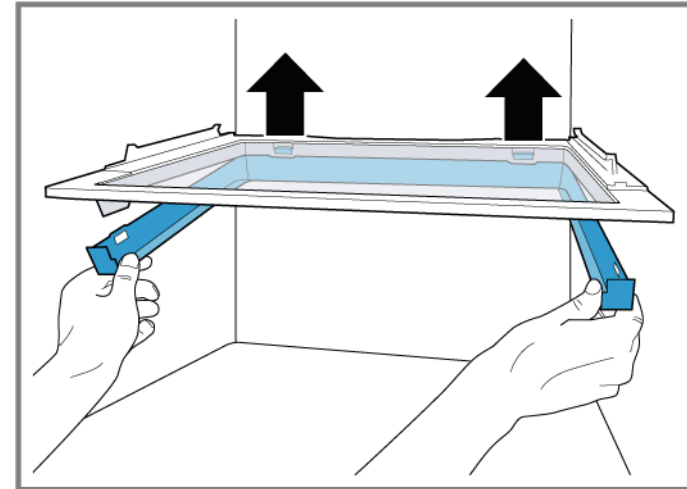

- ➡ Die hinteren Haken werden freigegeben.

3. Den Dichtungsrahmen entnehmen.
4. Die Ablage über dem Obst- und Gemüsebehälter anheben und seitlich heraus-schwenken.

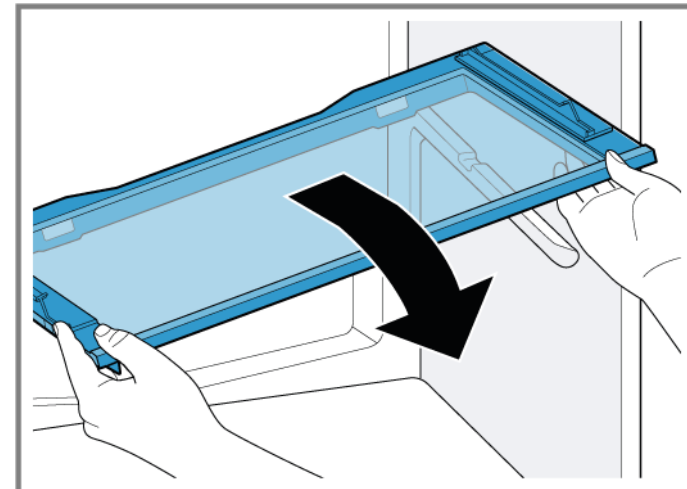

- ➡ Die Ablage über dem Obst- und Gemüsebehälter ist entfernt.

4.12.2 Einbauen der Ablage über dem Obst- und Gemüsebehälter

- ▶ Der Einbau erfolgt in umgekehrter Reihenfolge.

4.13 Austauschen des Gefriergutbehälters

Voraussetzung:

- ✔ Die Tür ist offen.

4.13.1 Ausbauen des Gefriergutbehälters

- ▶ 1. Den Gefriergutbehälter vollständig herausziehen (1).
- ▶ 2. Den Gefriergutbehälter entfernen (2).

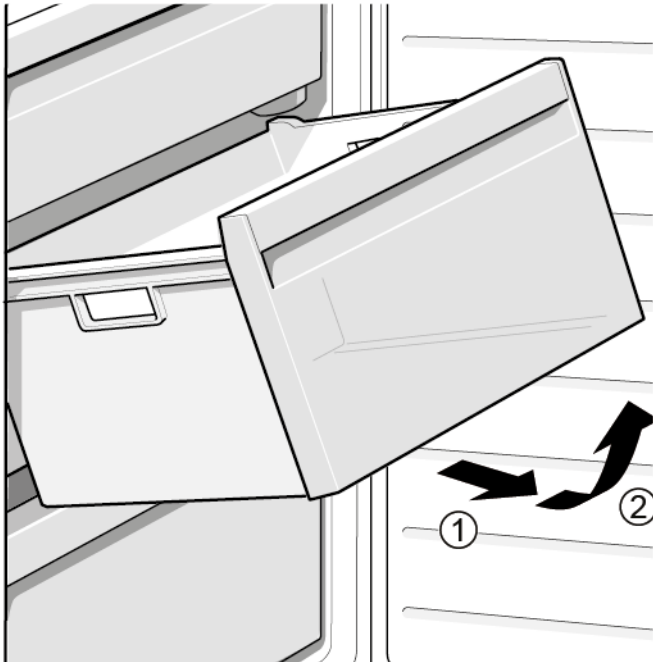

- ➡ Der Gefriergutbehälter ist entfernt.

4.13.2 Einbauen des Gefriergutbehälters

- ▶ Der Einbau erfolgt in umgekehrter Reihenfolge.

4.14 Austauschen der oberen LED-Lampe

Spezielle Hilfsmittel:

🔧 Spezialwerkzeug

[00342180]

i Das Gerät ist mit einer wartungsfreien LED-Beleuchtung ausgestattet. Reparaturen an dieser Beleuchtung dürfen nur vom Kundendienst oder von autorisierten Fachkräften ausgeführt werden!

⚠️ GEFAHR
Stromschlaggefahr durch spannungsführende Teile!
 Lebensgefahr durch Stromschlag bei unsachgemäßer Reparatur

- ▶ Elektroteile sollten von einer Elektrofachkraft repariert werden.
- ▶ Nach der Reparatur muss eine Sicherheitsprüfung nach VDE 0701 oder länderspezifischen Vorschriften durchgeführt werden.

⚠️ GEFAHR
Stromschlaggefahr durch spannungsführende Teile!
 Tod durch Stromschlag

- ▶ Gerät mindestens 60 Sekunden vor Reparaturbeginn vom Netz trennen.

⚠️ VORSICHT
Scharfe Kanten!
 Schnittverletzungen

- ▶ Schutzhandschuhe tragen.

Voraussetzung:

- ✅ Das Gerät ist spannungsfrei.
- ✅ Die Tür ist offen.

4.14.1 Ausbauen der oberen LED-Lampe

1. Das Demontagewerkzeug zwischen der oberen LED-Lampe und der Kühlfach-Innenverkleidung einschieben, um die Lampenhaken zu lösen (1).
2. Die obere LED-Lampe entfernen (2).

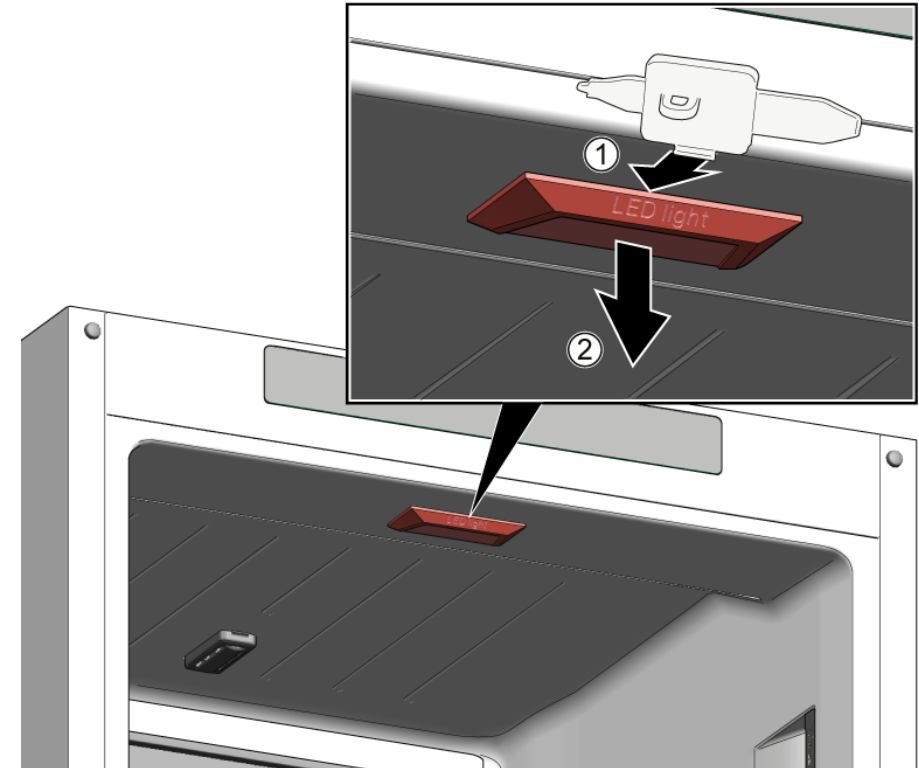

2. Den elektrischen Anschluss der oberen LED-Lampe trennen.
- ➡ Die obere LED-Lampe ist ausgebaut.

4.14.2 Einbauen der oberen LED-Lampe

- ▶ Der Einbau erfolgt in umgekehrter Reihenfolge.

4.15 Austauschen der seitlichen LED-Lampe

Spezielle Hilfsmittel:

Spezialwerkzeug [00342180]

i Das Gerät ist mit einer wartungsfreien LED-Beleuchtung ausgestattet. Reparaturen an dieser Beleuchtung dürfen nur vom Kundendienst oder von autorisierten Fachkräften ausgeführt werden!

⚠ GEFAHR
Stromschlaggefahr durch spannungsführende Teile!
 Lebensgefahr durch Stromschlag bei unsachgemäßer Reparatur

- ▶ Elektroteile sollten von einer Elektrofachkraft repariert werden.
- ▶ Nach der Reparatur muss eine Sicherheitsprüfung nach VDE 0701 oder länderspezifischen Vorschriften durchgeführt werden.

⚠ GEFAHR
Stromschlaggefahr durch spannungsführende Teile!
 Tod durch Stromschlag

- ▶ Gerät mindestens 60 Sekunden vor Reparaturbeginn vom Netz trennen.

⚠ VORSICHT
Scharfe Kanten!
 Schnittverletzungen

- ▶ Schutzhandschuhe tragen.

⚠ ACHTUNG
Gefahr der Beschädigung elektrostatisch gefährdeter Bauteile (elektrostatische Entladungen)!!
 Beschädigung von Bauteilen

- ▶ Vor dem Berühren elektrostatisch gefährdeter Bauteile ein Elektrostatischeschutzsystem (Handgelenkband mit Erdungsbaustein) anlegen.
- ▶ Anschlüsse und Leiterbahnen der Module nicht berühren.
- ▶ Elektrostatisch gefährdete Bauteile nur in leitfähigen Materialien oder in der Originalverpackung transportieren.
- ▶ Elektrostatisch gefährdete Bauteile von elektrostatisch aufladbaren Materialien (z. B. Kunststoffen) fernhalten.

Voraussetzung:

- ✓ Das Gerät ist spannungsfrei.
- ✓ Die Tür ist offen.
- ✓ Die Kühlfach-Innenausstattungsteile sind entfernt.

4.15.1 Ausbauen der seitlichen LED-Lampe

1. Das Demontagewerkzeug zwischen Lampendiffusor und Gehäuse einschieben, um die Rastung zu lösen (1).
2. Den Lampendiffusor entnehmen (2).
3. Die nachfolgenden Diffusor-Befestigungshaken auf die gleiche Weise lösen.

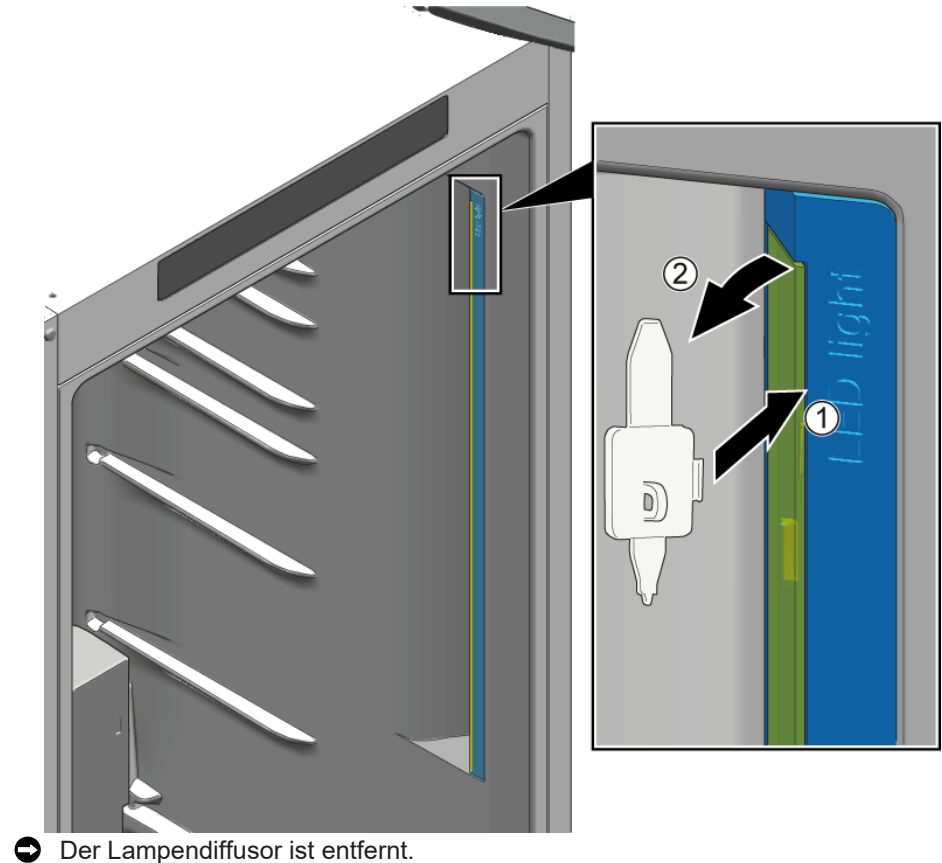

Instandsetzen

1. Druck auf den Befestigungshaken ausüben, um ihn zu lösen (1).
2. Das LED-Modul etwa 1 cm nach oben bewegen, um es aus seiner Fassung zu entfernen (2).
3. Das LED-Modul entnehmen (3).

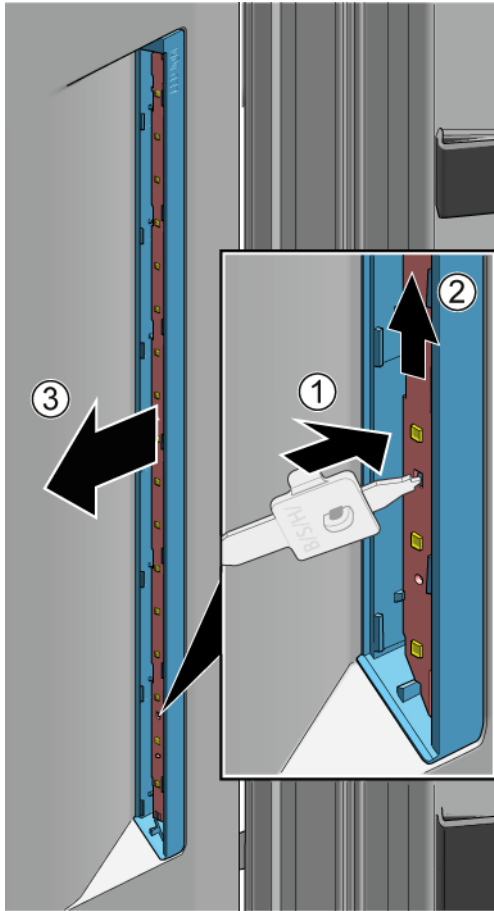

 Die seitliche LED-Lampe ist ausgebaut.

4.15.2 Einbauen der seitlichen LED-Lampe



Da die Haken des Lampendiffusers beim Entfernen leicht brechen können, besteht das Ersatzteil für die seitliche LED-Lampe aus dem LED-Modul und dem Lampendiffuser.

1. Das Demotagewerkzeug zwischen Lampendiffuser und Gehäuse einschieben, um die Rastung zu lösen (1).
2. Den Lampendiffuser entnehmen (2).
3. Die nachfolgenden Diffuser-Befestigungshaken auf die gleiche Weise lösen.

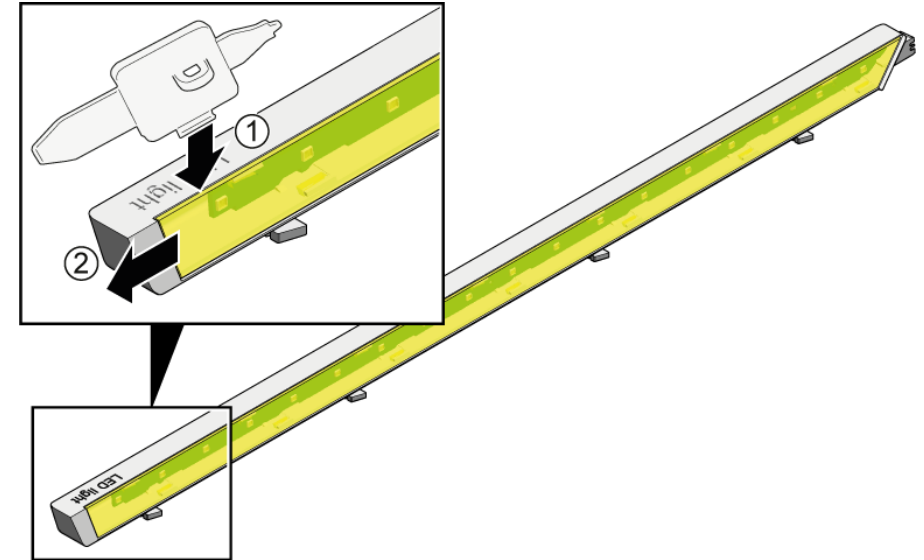

Instandsetzen

2. 1. Druck auf den Befestigungshaken ausüben, um ihn zu lösen (1).
2. Das LED-Modul nach oben aus dem Gehäuse herausschieben.
3. Das LED-Modul-Gehäuse entsorgen. Es dient aus Sicherheitsgründen als Ersatzteil-Transportschutz (3).

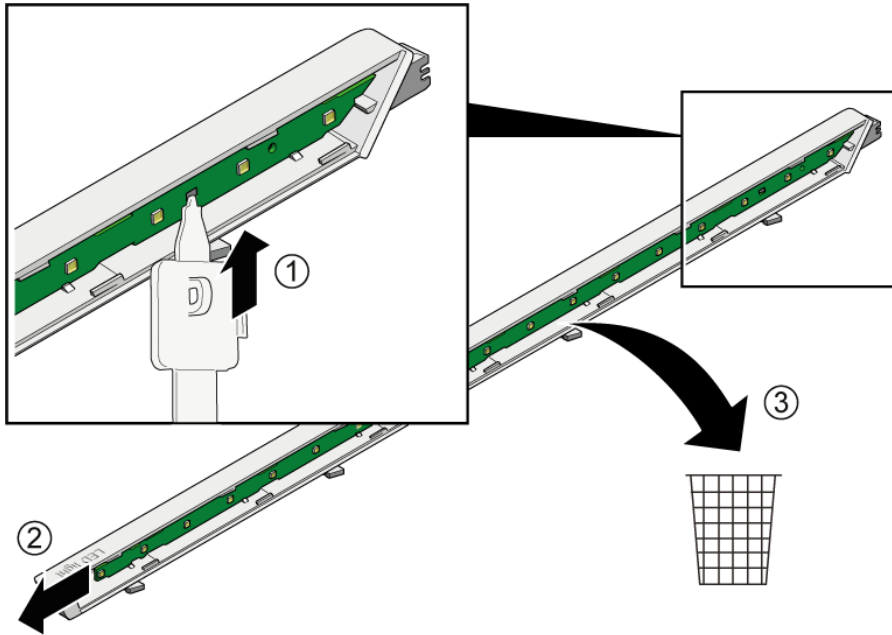

3. Der Einbau des LED-Moduls und des Lampendiffusors erfolgt in umgekehrter Reihenfolge zum Ausbau.

4.16 Austauschen der Gefrierfach-LED-Lampe

Spezielle Hilfsmittel:

Spezialwerkzeug [00342180]

i Das Gerät ist mit einer wartungsfreien LED-Beleuchtung ausgestattet. Reparaturen an dieser Beleuchtung dürfen nur vom Kundendienst oder von autorisierten Fachkräften ausgeführt werden!

⚠ GEFAHR
Stromschlaggefahr durch spannungsführende Teile!
 Lebensgefahr durch Stromschlag bei unsachgemäßer Reparatur

- ▶ Elektroteile sollten von einer Elektrofachkraft repariert werden.
- ▶ Nach der Reparatur muss eine Sicherheitsprüfung nach VDE 0701 oder länderspezifischen Vorschriften durchgeführt werden.

⚠ GEFAHR
Stromschlaggefahr durch spannungsführende Teile!
 Tod durch Stromschlag

- ▶ Gerät mindestens 60 Sekunden vor Reparaturbeginn vom Netz trennen.

⚠ VORSICHT
Scharfe Kanten!
 Schnittverletzungen

- ▶ Schutzhandschuhe tragen.

Voraussetzung:

- ✓ Das Gerät ist spannungsfrei.
- ✓ Die Tür ist offen.

4.16.1 Ausbauen der Gefrierfach-LED-Lampe

- ▶ 1. Das Demontagewerkzeug an der Seite der Lampe zwischen der Lampe und dem Gehäuse einschieben, sodass ein Spalt entsteht (1).
- ▶ 2. Das Demontagewerkzeug auf der anderen Seite des Lampenbefestigungshakens einschieben und nach vorn drehen (2).
- ▶ 3. Die Gefrierfach-LED-Lampe entfernen (3).

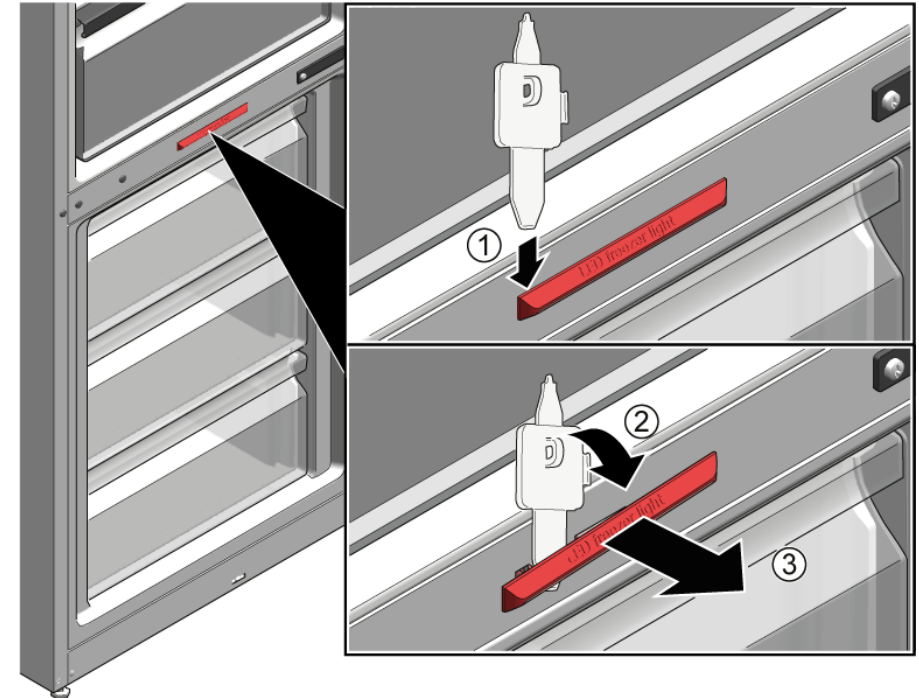





- ➡ Die Gefrierfach-LED-Lampe ist getrennt.
- ➡ Die Gefrierfach-LED-Lampe ist ausgebaut.

4.16.2 Einbauen der Gefrierfach-LED-Lampe

- ▶ Der Einbau erfolgt in umgekehrter Reihenfolge.

Υποδείξεις επισκευής - Ψυγειοκαταψύκτης

 Σχετικά με αυτό το έγγραφο	300
1.1 Σημαντικές πληροφορίες.....	300
1.1.1 Σκοπός.....	300
1.2 Επεξήγηση συμβόλων.....	300
1.2.1 Επίπεδα κινδύνου.....	300
1.2.2 Σύμβολα κινδύνου.....	300
1.2.3 Δομή των προειδοποιήσεων.....	301
1.2.4 Γενικά σύμβολα.....	301
 Ασφάλεια	302
2.1 Γενικές οδηγίες ασφαλείας.....	302
2.1.1 Όλες οι οικιακές συσκευές.....	302
 Εργαλεία και βοηθήματα	303
 Επισκευή	304
4.1 Αντικατάσταση στεγανοποιητικού πόρτας.....	304
4.1.1 Αφαίρεση στεγανοποιητικού πόρτας.....	304
4.1.2 Τοποθέτηση στεγανοποιητικού πόρτας.....	304
4.2 Αντικατάσταση λαβής πόρτας.....	307
4.2.1 Αφαίρεση λαβής πόρτας.....	307
4.2.2 Τοποθέτηση λαβής πόρτας.....	307
4.3 Αντικατάσταση επάνω μεντεσέ πόρτας.....	308
4.3.1 Αφαίρεση επάνω μεντεσέ πόρτας.....	308
4.3.2 Τοποθέτηση επάνω μεντεσέ πόρτας.....	309
4.4 Αντικατάσταση επάνω μεντεσέ πόρτας (πόρτα με οθόνη).....	310
4.4.1 Αφαίρεση επάνω μεντεσέ πόρτας.....	311
4.4.2 Τοποθέτηση επάνω μεντεσέ πόρτας.....	312
4.5 Αντικατάσταση μεσαίου μεντεσέ πόρτας.....	313
4.5.1 Αφαίρεση μεσαίου μεντεσέ πόρτας.....	313
4.5.2 Τοποθέτηση μεσαίου μεντεσέ πόρτας.....	314
4.6 Αντικατάσταση κάτω μεντεσέ πόρτας.....	315
4.6.1 Αφαίρεση κάτω μεντεσέ πόρτας.....	315
4.6.2 Τοποθέτηση κάτω μεντεσέ πόρτας.....	315
4.7 Αντικατάσταση ραφιού.....	316
4.7.1 Αφαίρεση ραφιού.....	316
4.7.2 Τοποθέτηση ραφιού.....	316

4.8 Αντικατάσταση επιφάνειας εναπόθεσης φιαλών.....	317
4.8.1 Αφαίρεση επιφάνειας εναπόθεσης φιαλών.....	317
4.8.2 Τοποθέτηση επιφάνειας εναπόθεσης φιαλών.....	317
4.9 Αντικατάσταση ραφιού πόρτας.....	318
4.9.1 Αφαίρεση ραφιού πόρτας.....	318
4.9.2 Τοποθέτηση ραφιού πόρτας.....	318
4.10 Αντικατάσταση δοχείου φύλαξης.....	319
4.10.1 Αφαίρεση δοχείου φύλαξης.....	319
4.10.2 Τοποθέτηση δοχείου φύλαξης.....	319
4.11 Αντικατάσταση συρταριού φρούτων και λαχανικών.....	320
4.11.1 Αφαίρεση συρταριού φρούτων και λαχανικών.....	320
4.11.2 Τοποθέτηση συρταριού φρούτων και λαχανικών.....	320
4.12 Αντικατάσταση ραφιού εναπόθεσης πάνω από το δοχείο φρούτων και λαχανικών.....	321
4.12.1 Αφαίρεση ραφιού εναπόθεσης πάνω από το δοχείο φρούτων και λαχανικών.....	321
4.12.2 Τοποθέτηση ραφιού εναπόθεσης πάνω από το δοχείο φρούτων και λαχανικών.....	322
4.13 Αντικατάσταση συρταριού κατεψυγμένων τροφίμων.....	323
4.13.1 Αφαίρεση συρταριού κατεψυγμένων τροφίμων.....	323
4.13.2 Τοποθέτηση συρταριού κατεψυγμένων τροφίμων.....	323
4.14 Αντικατάσταση επάνω λυχνίας LED.....	324
4.14.1 Αφαίρεση επάνω λυχνίας LED.....	324
4.14.2 Τοποθέτηση επάνω λυχνίας LED.....	324
4.15 Αντικατάσταση πλευρικής λυχνίας LED.....	325
4.15.1 Αφαίρεση πλευρικής λυχνίας LED.....	326
4.15.2 Τοποθέτηση πλευρικής λυχνίας LED.....	326
4.16 Αντικατάσταση λυχνίας LED καταψύκτη.....	328
4.16.1 Αφαίρεση λυχνίας LED καταψύκτη.....	328
4.16.2 Τοποθέτηση λυχνίας LED καταψύκτη.....	328

i Σχετικά με αυτό το έγγραφο

1.1 Σημαντικές πληροφορίες

1.1.1 Σκοπός

Αυτές οι συμβουλές επισκευών υποστηρίζουν τους καταναλωτές στην επισκευή των συσκευών από τους ίδιους, σύμφωνα με τον ισχύοντα κανονισμό οικολογικού σχεδιασμού (από τις 03/2021).



Περιέχουν πληροφορίες για την αντικατάσταση ορισμένων ανταλλακτικών, συμπεριλαμβανομένων προειδοποιήσεων και κινδύνων.

Σε περίπτωση ερωτήσεων, επικοινωνήστε με το τμήμα εξυπηρέτησης πελατών της εταιρείας μας. Φέρουμε ευθύνη για τις ζημιές εάν οι συμβουλές επισκευής έχουν ακολουθηθεί σωστά.

1.2 Επεξήγηση συμβόλων

1.2.1 Επίπεδα κινδύνου

Τα επίπεδα προειδοποίησης ασφάλειας αποτελούνται από ένα σύμβολο και μια λέξη. Η λέξη προειδοποίησης προσδιορίζει τη σοβαρότητα του κινδύνου.





Επίπεδο προειδοποίησης	Σημασία
 ΚΙΝΔΥΝΟΣ	Η μη τήρηση του προειδοποιητικού μηνύματος θα οδηγήσει σε θάνατο ή σε σοβαρούς τραυματισμούς.
 ΠΡΟΕΙΔΟΠΟΙΗΣΗ	Η μη τήρηση του προειδοποιητικού μηνύματος θα μπορούσε να οδηγήσει σε θάνατο ή σε σοβαρούς τραυματισμούς.
 ΠΡΟΣΟΧΗ	Η μη τήρηση του προειδοποιητικού μηνύματος θα μπορούσε να οδηγήσει σε μικρούς τραυματισμούς.
 ΠΡΟΣΟΧΗ!	Η μη τήρηση του προειδοποιητικού μηνύματος θα μπορούσε να οδηγήσει σε υλικές ζημιές της ιδιοκτησίας.

Πίνακας 1: Επίπεδα κινδύνου





1.2.2 Σύμβολα κινδύνου

Τα σύμβολα κινδύνου είναι συμβολικές αναπαραστάσεις που δίνουν μια ένδειξη για το είδος του κινδύνου.

Τα ακόλουθα σύμβολα κινδύνου χρησιμοποιούνται στο παρόν έγγραφο:

Σύμβολο κινδύνου	Σημασία
	Γενικό προειδοποιητικό μήνυμα
	Κίνδυνος από ηλεκτρική τάση
	Κίνδυνος έκρηξης
	Κίνδυνος κοψίματος

i Σχετικά με αυτό το έγγραφο

Σύμβολο κινδύνου	Σημασία
	Κίνδυνος σύνθλιψης
	Κίνδυνος από καυτές επιφάνειες
	Κίνδυνος από ισχυρό μαγνητικό πεδίο
	Κίνδυνος από μη ιονίζουσα ακτινοβολία

Πίνακας 2: Σύμβολα κινδύνου

1.2.3 Δομή των προειδοποιήσεων

.Οι προειδοποιήσεις σε αυτό το έγγραφο έχουν μια τυποποιημένη εμφάνιση και μια τυποποιημένη δομή.









	⚠ ΚΙΝΔΥΝΟΣ
Είδος και πηγή κινδύνου!	
Πιθανές συνέπειες εάν αγνοήσετε τον κίνδυνο/την προειδοποίηση.	
▶ Μέτρα και απαγορεύσεις για την πρόληψη του κινδύνου.	

Το παρακάτω παράδειγμα δείχνει μια προειδοποίηση που προειδοποιεί κατά της ηλεκτροπληξίας λόγω ηλεκτροφόρων μερών. Αναφέρεται το μέτρο για την αποφυγή του κινδύνου.

	⚠ ΚΙΝΔΥΝΟΣ
Κίνδυνος ηλεκτροπληξίας λόγω ηλεκτροφόρων μερών!	
Θάνατος από ηλεκτροπληξία	
▶ Αποσυνδέετε τις συσκευές από την παροχή ηλεκτρικού ρεύματος τουλάχιστον 60 δευτερόλεπτα πριν ξεκινήσετε τις επισκευές.	

1.2.4 Γενικά σύμβολα

Τα ακόλουθα γενικά σύμβολα χρησιμοποιούνται στο παρόν έγγραφο:

Γεν. σύμβολο	Σημασία
	Ταυτοποίηση μιας ειδικής συμβουλής (κειμένου ή/και γραφικών)
	Ταυτοποίηση μιας ειδικής συμβουλής (μόνο κειμένου)
	Ταυτοποίηση συνδέσμου ή εκπαιδευτικού βίντεο
	Ταυτοποίηση απαραίτητων εργαλείων
	Ταυτοποίηση απαραίτητων προϋποθέσεων
	Ταυτοποίηση μιας συνθήκης (αν ..., κατόπιν ...)
	Ταυτοποίηση αποτελέσματος
	Ταυτοποίηση ενός πλήκτρου ή κουμπιού
[00123456]	Ταυτοποίηση ενός κωδικού ανταλλακτικού
Κατάσταση	Ταυτοποίηση εμφανιζόμενου κειμένου/ παραθύρου (στην οθόνη της συσκευής)

Πίνακας 3: Γενικά σύμβολα

2.1 Γενικές οδηγίες ασφαλείας

2.1.1 Όλες οι οικιακές συσκευές

Κίνδυνος ηλεκτροπληξίας λόγω ηλεκτροφόρων μερών!

- Τα σφάλματα από επισκευές σε ηλεκτρικά εξαρτήματα μπορεί να προκαλέσουν ηλεκτροπληξία!
- Αποσυνδέστε τη συσκευή από την πρίζα για τουλάχιστον 60 δευτερόλεπτα πριν από την έναρξη των εργασιών.
- Μετά την επισκευή πραγματοποιήστε έλεγχο ασφαλείας σύμφωνα με το VDE 0701 ή κανονισμούς της συγκεκριμένης χώρας.

Κίνδυνος τραυματισμού από κοφτερές άκρες!

- Φοράτε προστατευτικά γάντια.

Κίνδυνος σύνθλιψης κατά την επισκευή, συντήρηση, αντιμετώπιση προβλημάτων και το σέρβις από βαριά και κινούμενα μέρη

- Φοράτε προστατευτικά υποδήματα.
- Ασφαλίστε τα βαριά μέρη από πτώση.
- Μην προσαρτάτε μέρη του πλαισίου στα κινούμενα μέρη.

Κίνδυνος για την ασφάλεια/τη λειτουργία της συσκευής!

- Χρησιμοποιείτε μόνο γνήσια ανταλλακτικά.

Κίνδυνος πρόκλησης βλάβης σε μέρη ευαίσθητα στον στατικό ηλεκτρισμό (ESDs)!

- Μην αγγίζετε τις μονάδες, συμπεριλαμβανομένων των συνδέσεων και των αγωγών των πλακετών.

Εργαλεία και βοηθήματα

Όνομασία	Λεπτομέριες	Εικόνες
Μύτη Torx TX20 [00340865]	6,3 mm (1/4")	
Ειδικό εργαλείο [00342180]		

4.1 Αντικατάσταση στεγανοποιητικού πόρτας

Προϋπόθεση:

- ✔ Η πόρτα είναι ανοιχτή.

4.1.1 Αφαίρεση στεγανοποιητικού πόρτας

1. Απελευθερώστε το στεγανοποιητικό πόρτας από την εγκοπή στη δεξιά και αριστερή γωνία.

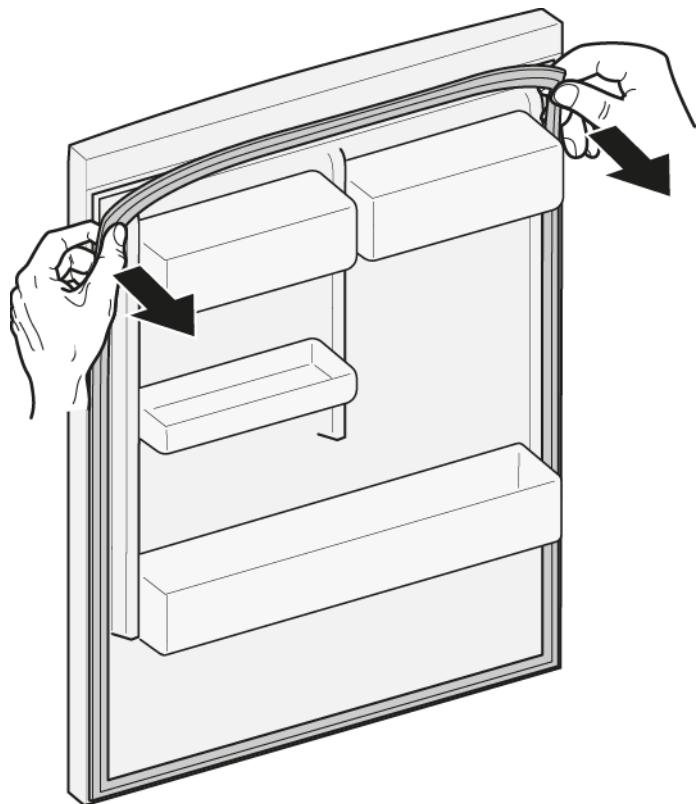

2. Τραβήξτε το στεγανοποιητικό πόρτας έξω από την εγκοπή.

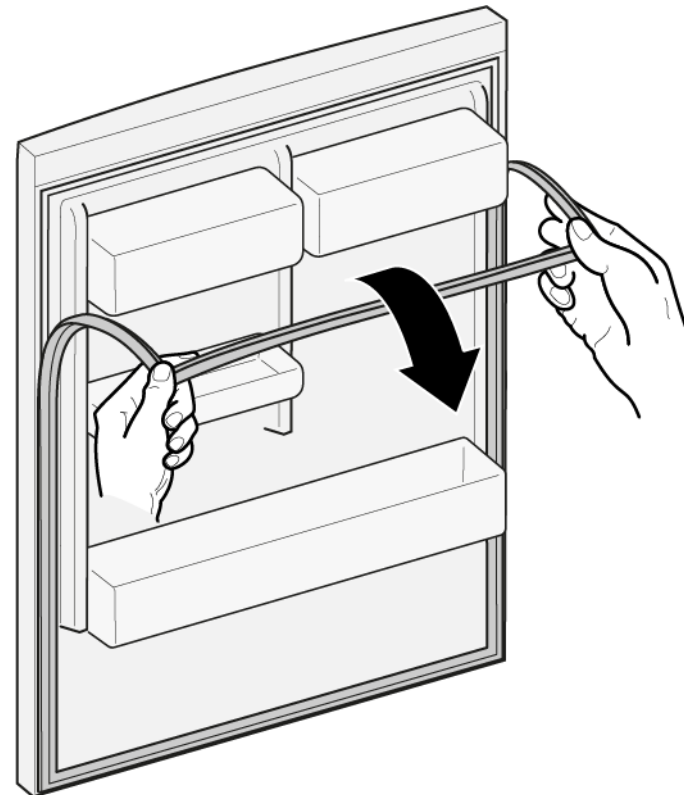

- ➡ Το στεγανοποιητικό της πόρτας έχει αφαιρεθεί.

4.1.2 Τοποθέτηση στεγανοποιητικού πόρτας



Το πάχος του νέου στεγανοποιητικού πόρτας μπορεί να αποκλίνει ελαφρώς από το πάχος του παλαιού στεγανοποιητικού πόρτας. Αυτό δεν θα επηρεάσει τη συμπεριφορά κλεισίματος και τη μακροπρόθεσμη λειτουργία.

Εάν η συσκευή σας έχεις προσαρμοζόμενους μεντεσέδες ή προσαρτήματα μεντεσέ, μπορεί να βελτιστοποιήσετε τη συμπεριφορά κλεισίματος αργότερα.

Οι μικρές οπές πλευρικά στο στεγανοποιητικό της πόρτας είναι λειτουργικές (απαραίτητες για τον αερισμό). Δεν είναι κατασκευαστικά ελαττώματα.

1. Ελέγξτε την εγκοπή για το στεγανοποιητικό για ζημιές.

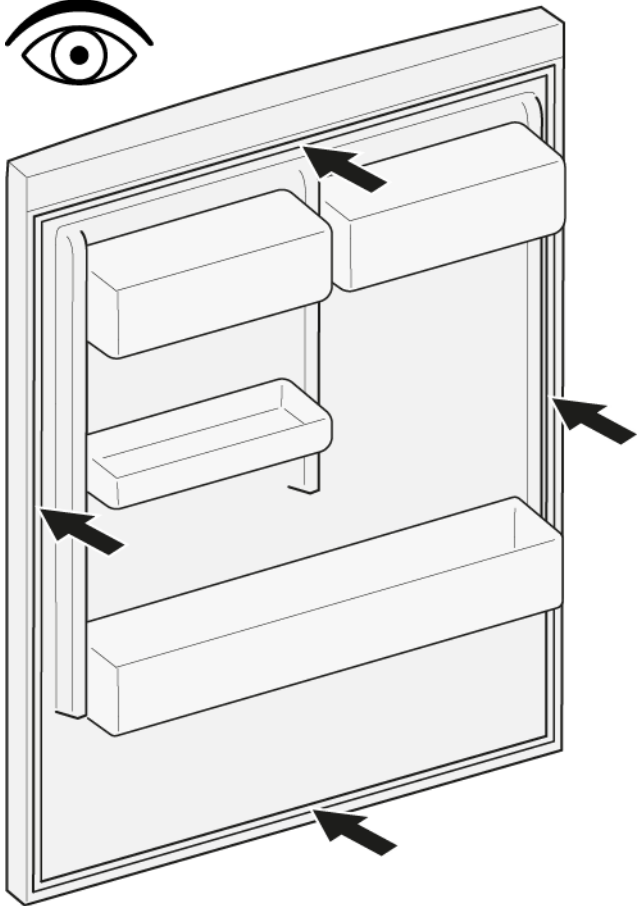

4. Πιέστε τις γωνίες του στεγανοποιητικού επάνω και κάτω στην εγκοπή.

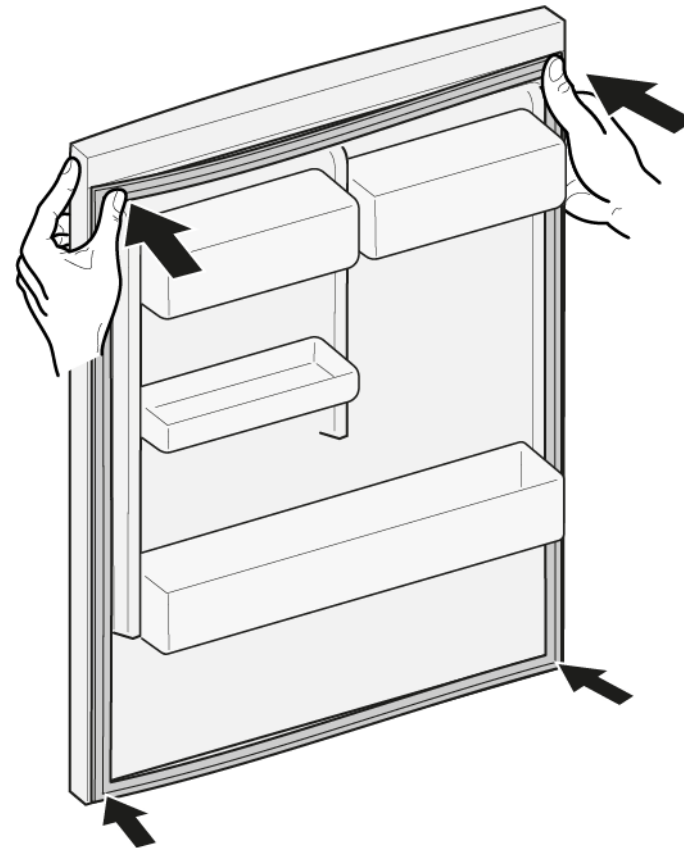

2. ⓘ Εάν η εγκοπή για στεγανοποιητικό είναι κατεστραμμένη.
- Επικοινωνήστε με την εξυπηρέτηση πελατών.

3.



Η ελαφριά παραμόρφωση του στεγανοποιητικού της πόρτας είναι φυσιολογική και δεν επηρεάζει τη λειτουργία της. Συνιστάται να ισιώνετε το στεγανοποιητικό της πόρτας πριν την τοποθετήσετε στη συσκευή.

Θερμάνετε το στεγανοποιητικό της πόρτας με πιστολάκι ή ζεστό νερό και αλλάξτε το σχήμα του με το χέρι.

5. Πιέστε ολόκληρο το στεγανοποιητικό βήμα βήμα στο εσωτερικό της εγκοπής.

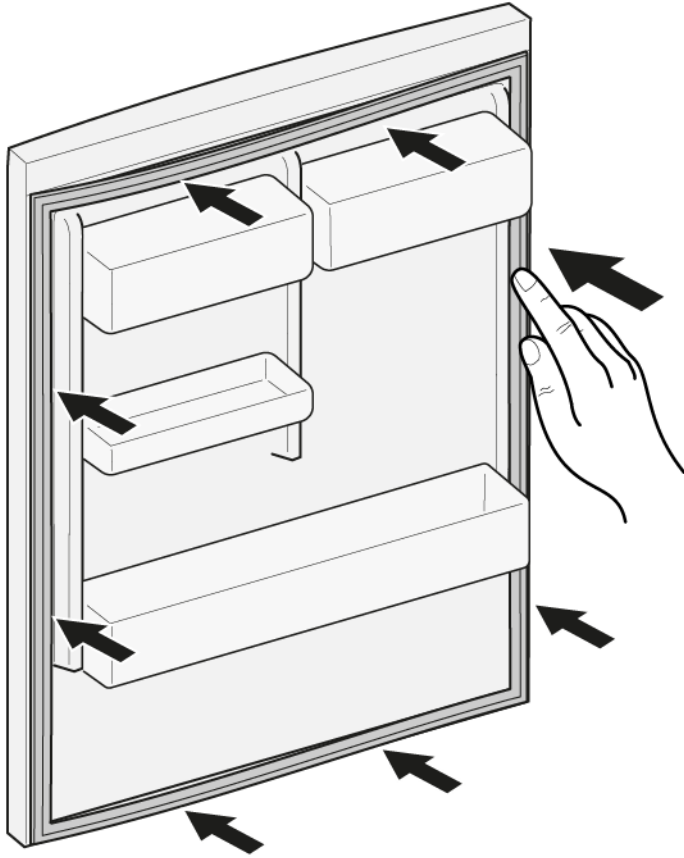

-  Το στεγανοποιητικό της πόρτας τοποθετήθηκε.

4.2 Αντικατάσταση λαβής πόρτας

Ειδικά βοηθητικά μέσα:

- Μύτη Torx TX20 6,3 mm (1/4") [00340865]
- Πλακέ κατσαβίδι Λεπίδα 10 mm x 1,6 mm x 200 mm

Προϋπόθεση:

- ✓ Η συσκευή είναι αποσυνδεδεμένη από την παροχή τροφοδοσίας.
- ✓ Η πόρτα είναι ανοιχτή.

4.2.1 Αφαίρεση λαβής πόρτας

- 1. Αφαιρέστε τα δύο πώματα βίδας (1).
- 2. Ξεβιδώστε δύο βίδες (2).
- 3. Αφαιρέστε τη λαβή της πόρτας (3).

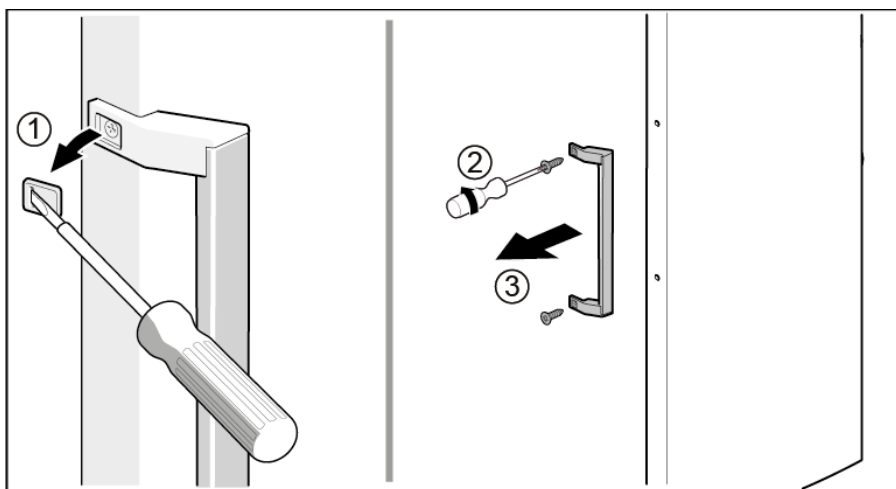

➔ Η λαβή της πόρτας έχει αφαιρεθεί.



Η λαβή πόρτας για τη δεύτερη πόρτα μπορεί να αφαιρεθεί με τον ίδιο τρόπο.

4.2.2 Τοποθέτηση λαβής πόρτας

- ▶ Εγκαταστήστε με την αντίθετη σειρά.

4.3 Αντικατάσταση επάνω μεντεσέ πόρτας

Ειδικά βοηθητικά μέσα:

 Μύτη Torx TX20 6,3 mm (1/4") [00340865]

	⚠ ΠΡΟΕΙΔΟΠΟΙΗΣΗ
Βαριές, ογκώδεις συσκευές! Τραυματισμοί μέσης και μυών	
<ul style="list-style-type: none"> ▶ Η διαδικασία αφαίρεσης της πόρτας της συσκευής πρέπει να εκτελείται μόνο από εκπαιδευμένους ειδικούς. ▶ Η μετακίνηση της συσκευής πρέπει να εκτελείται από δύο άτομα. ▶ Χρησιμοποιείτε μόνο κατάλληλα εργαλεία και εξοπλισμό. 	



	⚠ ΠΡΟΣΟΧΗ
Αιχμηρές ακμές! Τραυματισμοί από κοπή	
<ul style="list-style-type: none"> ▶ Φοράτε προστατευτικά γάντια. 	

	⚠ ΠΡΟΕΙΔΟΠΟΙΗΣΗ
Ολίσθηση κεκλιμένων συσκευών! Κατάγματα οστών/τραυματισμοί σύνθλιψης	
<ul style="list-style-type: none"> ▶ Ασφαλίστε τις συσκευές από ολίσθηση. 	

	⚠ ΠΡΟΣΟΧΗ
Κίνδυνοι από πτώση μερών εξαιτίας χαλαρών βιδών! Τραυματισμός εξαιτίας πτώσης τμημάτων.	
<ul style="list-style-type: none"> ▶ Ασφαλίστε τα εξαρτήματα από πτώση. 	

	ΠΡΟΣΟΧΗ!
Κίνδυνων από πτώση εξαρτημάτων εξαιτίας χαλαρών βιδών! Ζημιά σε άλλα μέρη της συσκευής ή στην οικία του πελάτη, π.χ. δάπεδο.	
<ul style="list-style-type: none"> ▶ Ασφαλίστε τα εξαρτήματα από πτώση. 	

Προϋπόθεση:

-  Η συσκευή είναι αποσυνδεδεμένη από την παροχή τροφοδοσίας.
-  Αφαιρούνται τα εσωτερικά εξαρτήματα συσκευής.

4.3.1 Αφαίρεση επάνω μεντεσέ πόρτας

1. Σύρετε το τμήμα υποστήριξης κάτω από την ενότητα βάσης.

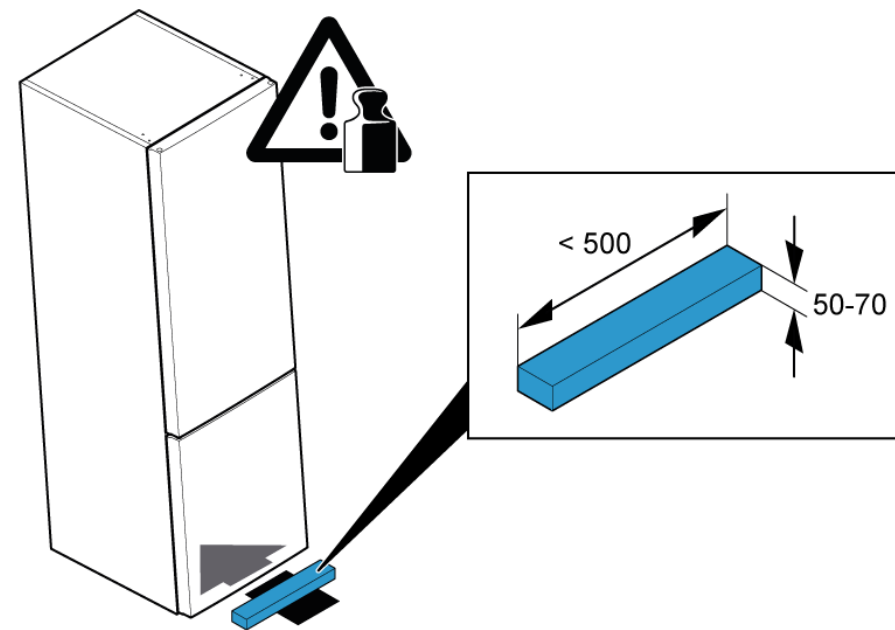

2.
 1. Αφαιρέστε το κάλυμμα επάνω μεντεσέ (1).
 2. Ξεβιδώστε δύο βίδες (2).
 3. Αφαιρέστε τον επάνω μεντεσέ (3).

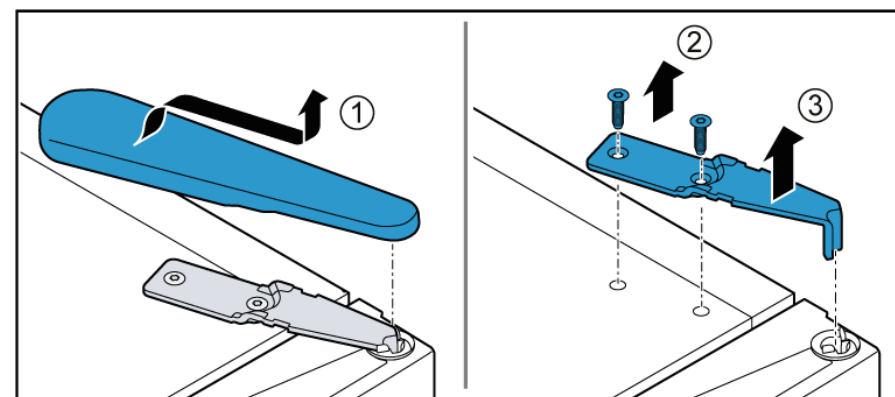

3. Αφαιρέστε την επάνω θύρα,

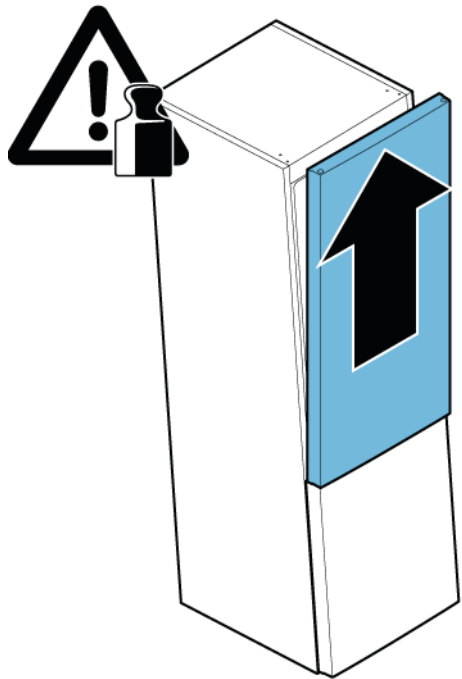

➡ Ο επάνω μεντεσές έχει αφαιρεθεί.

4.3.2 Τοποθέτηση επάνω μεντεσέ πόρτας

▶ Εγκαταστήστε με την αντίθετη σειρά.

4.4 Αντικατάσταση επάνω μεντεσέ πόρτας (πόρτα με θόνη)

Ειδικά βοηθητικά μέσα:

 Μύτη Torx TX20 6,3 mm (1/4") [00340865]

	⚠ ΠΡΟΕΙΔΟΠΟΙΗΣΗ
	<p>Βαριές, ογκώδεις συσκευές! Τραυματισμοί μέσης και μυών</p> <ul style="list-style-type: none"> ▶ Η διαδικασία αφαίρεσης της πόρτας της συσκευής πρέπει να εκτελείται μόνο από εκπαιδευμένους ειδικούς. ▶ Η μετακίνηση της συσκευής πρέπει να εκτελείται από δύο άτομα. ▶ Χρησιμοποιείτε μόνο κατάλληλα εργαλεία και εξοπλισμό.

	⚠ ΠΡΟΣΟΧΗ
	<p>Αιχμηρές ακμές! Τραυματισμοί από κοπή</p> <ul style="list-style-type: none"> ▶ Φοράτε προστατευτικά γάντια.

	⚠ ΠΡΟΕΙΔΟΠΟΙΗΣΗ
	<p>Ολίσθηση κεκλιμένων συσκευών! Κατάγματα οστών/τραυματισμοί σύνθλιψης</p> <ul style="list-style-type: none"> ▶ Ασφαλίστε τις συσκευές από ολίσθηση.



	⚠ ΠΡΟΣΟΧΗ
	<p>Κίνδυνοι από πτώση μερών εξαιτίας χαλαρών βιδών! Τραυματισμός εξαιτίας πτώσης τμημάτων.</p> <ul style="list-style-type: none"> ▶ Ασφαλίστε τα εξαρτήματα από πτώση.

	ΠΡΟΣΟΧΗ!
	<p>Κίνδυνων από πτώση εξαρτημάτων εξαιτίας χαλαρών βιδών! Ζημιά σε άλλα μέρη της συσκευής ή στην οικία του πελάτη, π.χ. δάπεδο.</p> <ul style="list-style-type: none"> ▶ Ασφαλίστε τα εξαρτήματα από πτώση.

	⚠ ΚΙΝΔΥΝΟΣ
	<p>Κίνδυνος ηλεκτροπληξίας λόγω ηλεκτροφόρων μερών! Κίνδυνος για τη ζωή από ηλεκτροπληξία σε περίπτωση ακατάλληλης επισκευής</p> <ul style="list-style-type: none"> ▶ Τα ηλεκτρικά μέρη πρέπει να επισκευάζονται από εκπαιδευμένους ηλεκτρολόγους. ▶ Μετά την επισκευή πραγματοποιήστε έλεγχο ασφάλειας σύμφωνα με το VDE 0701 ή κανονισμούς της συγκεκριμένης χώρας.

	⚠ ΚΙΝΔΥΝΟΣ
	<p>Κίνδυνος ηλεκτροπληξίας λόγω ηλεκτροφόρων μερών! Θάνατος από ηλεκτροπληξία</p> <ul style="list-style-type: none"> ▶ Αποσυνδέετε τις συσκευές από την παροχή ηλεκτρικού ρεύματος τουλάχιστον 60 δευτερόλεπτα πριν ξεκινήσετε τις επισκευές.

Προϋπόθεση:

-  Η συσκευή είναι αποσυνδεδεμένη από την παροχή τροφοδοσίας.
-  Αφαιρούνται τα εσωτερικά εξαρτήματα συσκευής.

4.4.1 Αφαίρεση επάνω μεντεσέ πόρτας

1. Σύρετε το τμήμα υποστήριξης κάτω από την ενότητα βάσης.

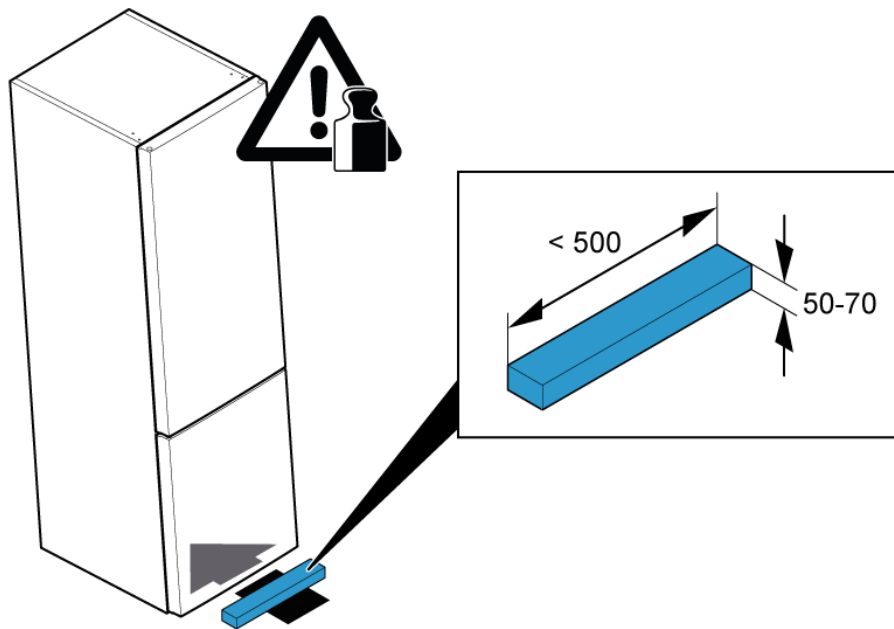

2. 1. Αφαιρέστε το κάλυμμα επάνω μεντεσέ (1).
2. Αποσυνδέστε την ηλεκτρική σύνδεση (2).
3. Ξεβιδώστε τη βίδα σύνδεσης γείωσης (3).

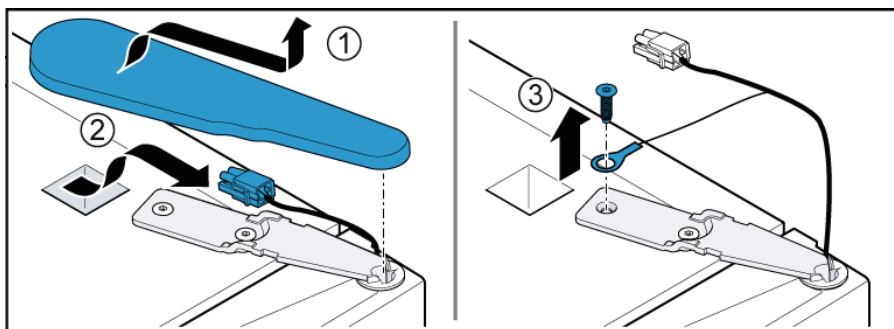

3. 1. Ξεβιδώστε τη βίδα (1).
2. Αφαιρέστε τον επάνω μεντεσέ (2).

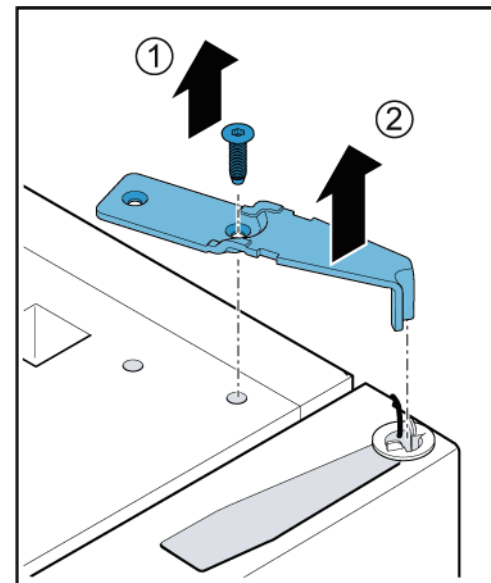

4. Αφαιρέστε την επάνω πόρτα.

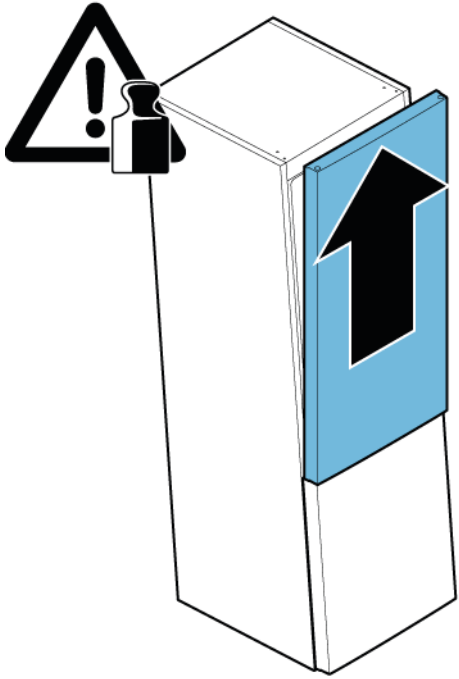

➡ Ο επάνω μεντεσές έχει αφαιρεθεί.

4.4.2 Τοποθέτηση επάνω μεντεσέ πόρτας

- ▶ Εγκαταστήστε με την αντίθετη σειρά.

4.5 Αντικατάσταση μεσαίου μεντεσέ πόρτας

Ειδικά βοηθητικά μέσα:

 Μύτη Torx TX20 6,3 mm (1/4") [00340865]

	<p style="text-align: center;">⚠ ΠΡΟΕΙΔΟΠΟΙΗΣΗ</p> <p>Βαριές, ογκώδεις συσκευές! Τραυματισμοί μέσης και μυών</p> <ul style="list-style-type: none"> ▶ Η διαδικασία αφαίρεσης της πόρτας της συσκευής πρέπει να εκτελείται μόνο από εκπαιδευμένους ειδικούς. ▶ Η μετακίνηση της συσκευής πρέπει να εκτελείται από δύο άτομα. ▶ Χρησιμοποιείτε μόνο κατάλληλα εργαλεία και εξοπλισμό.
--	--





	<p style="text-align: center;">⚠ ΠΡΟΣΟΧΗ</p> <p>Αιχμηρές ακμές! Τραυματισμοί από κοπή</p> <ul style="list-style-type: none"> ▶ Φοράτε προστατευτικά γάντια.
--	--

	<p style="text-align: center;">⚠ ΠΡΟΕΙΔΟΠΟΙΗΣΗ</p> <p>Ολίσθηση κεκλιμένων συσκευών! Κατάγματα οστών/τραυματισμοί σύνθλιψης</p> <ul style="list-style-type: none"> ▶ Ασφαλίστε τις συσκευές από ολίσθηση.
--	---

	<p style="text-align: center;">⚠ ΠΡΟΣΟΧΗ</p> <p>Κίνδυνοι από πτώση μερών εξαιτίας χαλαρών βιδών! Τραυματισμός εξαιτίας πτώσης τμημάτων.</p> <ul style="list-style-type: none"> ▶ Ασφαλίστε τα εξαρτήματα από πτώση.
---	--

	<p style="text-align: center;">ΠΡΟΣΟΧΗ!</p> <p>Κίνδυνων από πτώση εξαρτημάτων εξαιτίας χαλαρών βιδών! Ζημιά σε άλλα μέρη της συσκευής ή στην οικία του πελάτη, π.χ. δάπεδο.</p> <ul style="list-style-type: none"> ▶ Ασφαλίστε τα εξαρτήματα από πτώση.
--	--

Προϋπόθεση:

-  Η συσκευή είναι αποσυνδεδεμένη από την παροχή τροφοδοσίας.
-  Αφαιρούνται τα εσωτερικά εξαρτήματα συσκευής.
-  Ο επάνω μεντεσές της θύρας έχει αφαιρεθεί.
-  Η επάνω θύρα έχει αφαιρεθεί.

4.5.1 Αφαίρεση μεσαίου μεντεσέ πόρτας

1. 1. Ξεβιδώστε δύο βίδες (1).
2. Αφαιρέστε τον μεσαίο μεντεσέ (2).

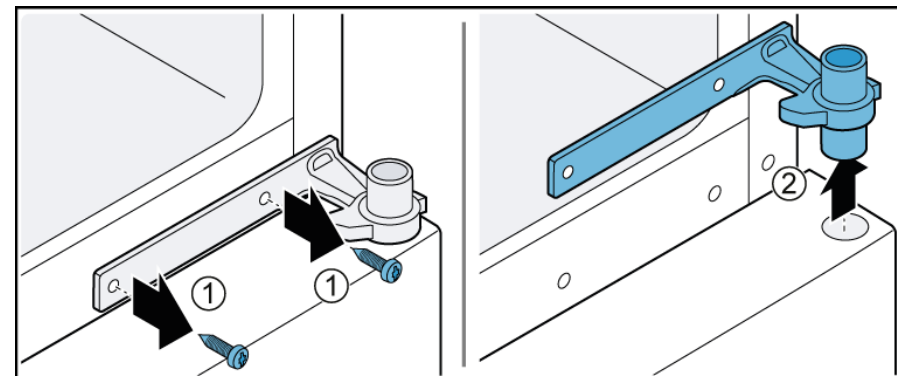

2. Αφαιρέστε την κάτω θύρα.

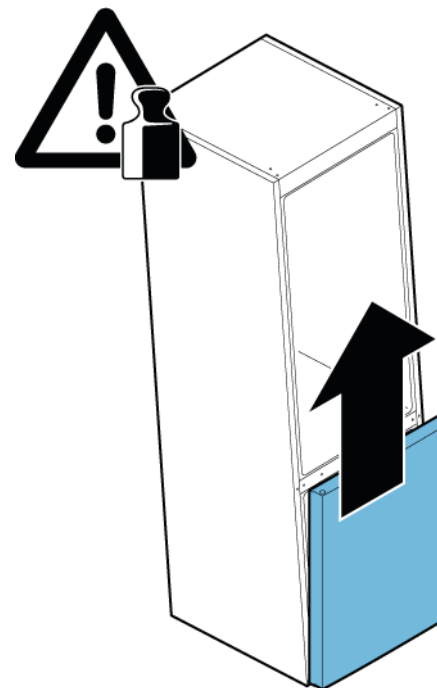

 Ο μεσαίος μεντεσές έχει αφαιρεθεί.

4.5.2 Τοποθέτηση μεσαίου μεντεσέ πόρτας

- ▶ Εγκαταστήστε με την αντίθετη σειρά.

4.6 Αντικατάσταση κάτω μεντεσέ πόρτας

Ειδικά βοηθητικά μέσα:

Μύτη Torx TX20 6,3 mm (1/4") [00340865]

	ΠΡΟΕΙΔΟΠΟΙΗΣΗ Βαριές, ογκώδεις συσκευές! Τραυματισμοί μέσης και μυών <ul style="list-style-type: none">▶ Η διαδικασία αφαίρεσης της πόρτας της συσκευής πρέπει να εκτελείται μόνο από εκπαιδευμένους ειδικούς.▶ Η μετακίνηση της συσκευής πρέπει να εκτελείται από δύο άτομα.▶ Χρησιμοποιείτε μόνο κατάλληλα εργαλεία και εξοπλισμό.
--	--

	ΠΡΟΣΟΧΗ Αιχμηρές ακμές! Τραυματισμοί από κοπή <ul style="list-style-type: none">▶ Φοράτε προστατευτικά γάντια.
--	--

	ΠΡΟΕΙΔΟΠΟΙΗΣΗ Ολίσθηση κεκλιμένων συσκευών! Κατάγματα οστών/τραυματισμοί σύνθλιψης <ul style="list-style-type: none">▶ Ασφαλίστε τις συσκευές από ολίσθηση.
--	---

	ΠΡΟΣΟΧΗ Κίνδυνοι από πτώση μερών εξαιτίας χαλαρών βιδών! Τραυματισμός εξαιτίας πτώσης τμημάτων. <ul style="list-style-type: none">▶ Ασφαλίστε τα εξαρτήματα από πτώση.
---	--

	ΠΡΟΣΟΧΗ! Κίνδυνων από πτώση εξαρτημάτων εξαιτίας χαλαρών βιδών! Ζημιά σε άλλα μέρη της συσκευής ή στην οικία του πελάτη, π.χ. δάπεδο. <ul style="list-style-type: none">▶ Ασφαλίστε τα εξαρτήματα από πτώση.
--	--

Προϋπόθεση:

- ✔ Η συσκευή είναι αποσυνδεδεμένη από την παροχή τροφοδοσίας.
- ✔ Αφαιρούνται τα εσωτερικά εξαρτήματα συσκευής.
- ✔ Ο επάνω μεντεσές έχει αφαιρεθεί.
- ✔ Ο μεσαίος μεντεσές έχει αφαιρεθεί.

4.6.1 Αφαίρεση κάτω μεντεσέ πόρτας

- ▶ 1. Ξεβιδώστε δύο βίδες (1).
- ▶ 2. Αφαιρέστε τον κάτω μεντεσέ (2).

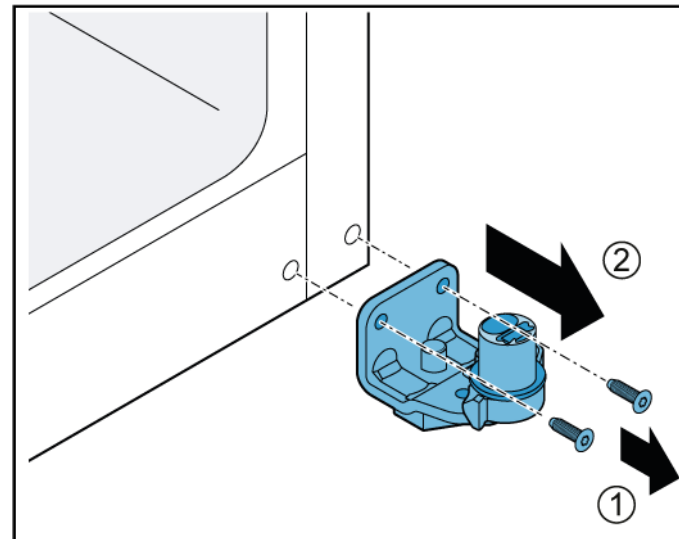

➡ Ο κάτω μεντεσές θύρας έχει αφαιρεθεί.

4.6.2 Τοποθέτηση κάτω μεντεσέ πόρτας

- ▶ Εγκαταστήστε με την αντίθετη σειρά.

4.7 Αντικατάσταση ραφιού

Προϋπόθεση:

- ✔ Η πόρτα είναι ανοιχτή.

4.7.1 Αφαίρεση ραφιού

- ▶ 1. Σηκώστε το ράφι πίσω (1).
- ▶ 2. Απελευθερώστε το συρτάρι (2).

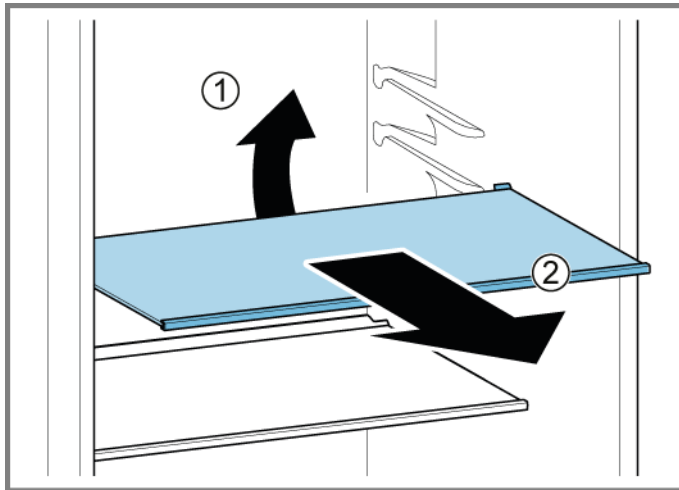

➡ Το ράφι αφαιρέθηκε.

4.7.2 Τοποθέτηση ραφιού

- ▶ Εγκαταστήστε με την αντίθετη σειρά.

4.8 Αντικατάσταση επιφάνειας εναπόθεσης φιαλών

Προϋπόθεση:

- ✔ Η πόρτα είναι ανοιχτή.

4.8.1 Αφαίρεση επιφάνειας εναπόθεσης φιαλών

- ▶ Τραβήξτε προς τα έξω την επιφάνεια εναπόθεσης φιαλών.

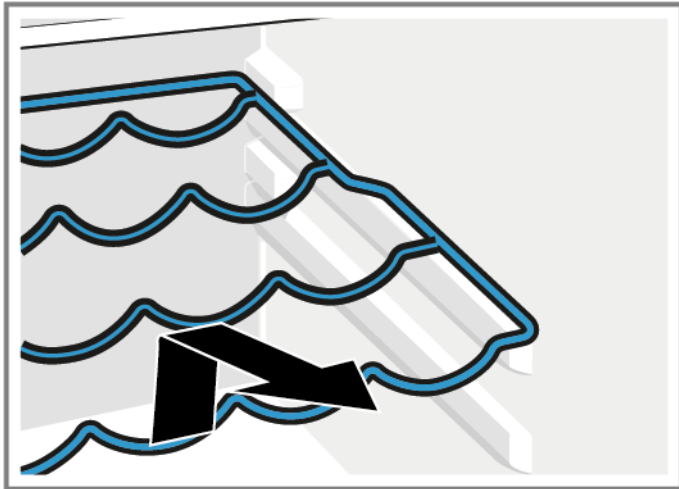

- ➡ Η επιφάνεια εναπόθεσης φιαλών έχει αφαιρεθεί.

4.8.2 Τοποθέτηση επιφάνειας εναπόθεσης φιαλών

- ▶ Εγκαταστήστε με την αντίθετη σειρά.

4.9 Αντικατάσταση ραφιού πόρτας

Προϋπόθεση:

- ✔ Η πόρτα είναι ανοιχτή.

4.9.1 Αφαίρεση ραφιού πόρτας

- ▶ Ανασηκώστε το ράφι πόρτας προς τα επάνω.

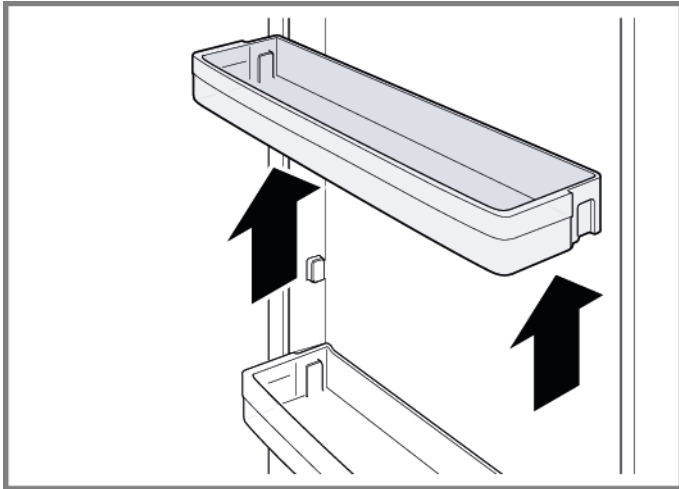

- ➡ Το ράφι πόρτας έχει αφαιρεθεί.

4.9.2 Τοποθέτηση ραφιού πόρτας

- ▶ Εγκαταστήστε με την αντίθετη σειρά.

4.10 Αντικατάσταση δοχείου φύλαξης

Προϋπόθεση:

- ✔ Η πόρτα είναι ανοιχτή.

4.10.1 Αφαίρεση δοχείου φύλαξης

1. Τραβήξτε προς τα έξω το δοχείο φύλαξης μέχρι τέρμα.
2. 1. Σηκώστε το δοχείο φύλαξης μπροστά (1).
2. Αφαιρέστε το συρτάρι (2).

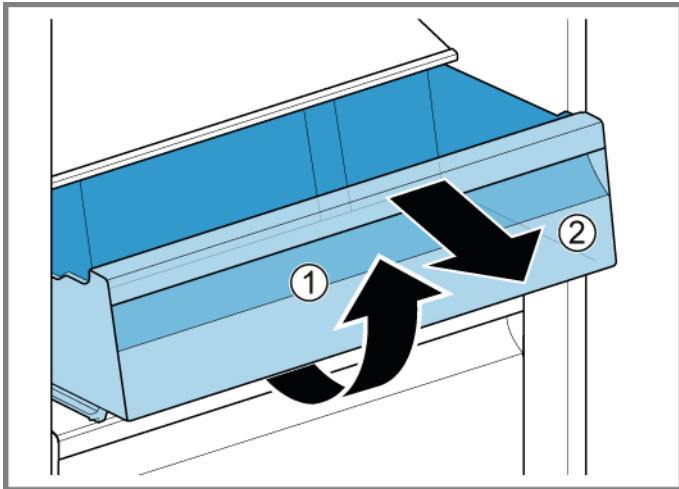

- ➔ Το δοχείο φύλαξης αφαιρέθηκε.

4.10.2 Τοποθέτηση δοχείου φύλαξης

- ▶ Εγκαταστήστε με την αντίθετη σειρά.

4.11 Αντικατάσταση συρταριού φρούτων και λαχανικών

Προϋπόθεση:

- ✔ Η πόρτα είναι ανοιχτή.

4.11.1 Αφαίρεση συρταριού φρούτων και λαχανικών

1. Τραβήξτε προς τα έξω το δοχείο φρούτων και λαχανικών μέχρι τέρμα.
2. 1. Ανασηκώστε το δοχείο φρούτων και λαχανικών μπροστά (1).
2. Αφαιρέστε το συρτάρι (2).

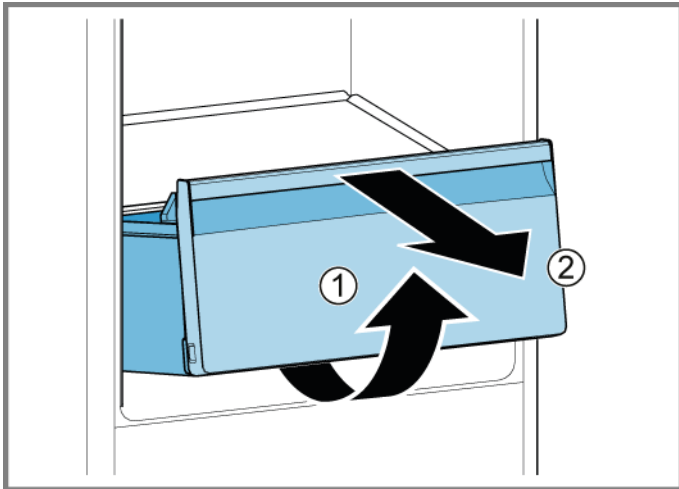

- ➡ Το δοχείο φρούτων και λαχανικών έχει αφαιρεθεί.

4.11.2 Τοποθέτηση συρταριού φρούτων και λαχανικών

- ▶ Εγκαταστήστε με την αντίθετη σειρά.

4.12 Αντικατάσταση ραφιού εναπόθεσης πάνω από το δοχείο φρούτων και λαχανικών

Προϋπόθεση:

- ✔ Η πόρτα είναι ανοιχτή.
- ✔ Το δοχείο φρούτων και λαχανικών έχει αφαιρεθεί. → 320

4.12.1 Αφαίρεση ραφιού εναπόθεσης πάνω από το δοχείο φρούτων και λαχανικών

1. Σπρώξτε το πλαίσιο στεγανοποίησης προς τα επάνω και έξω.

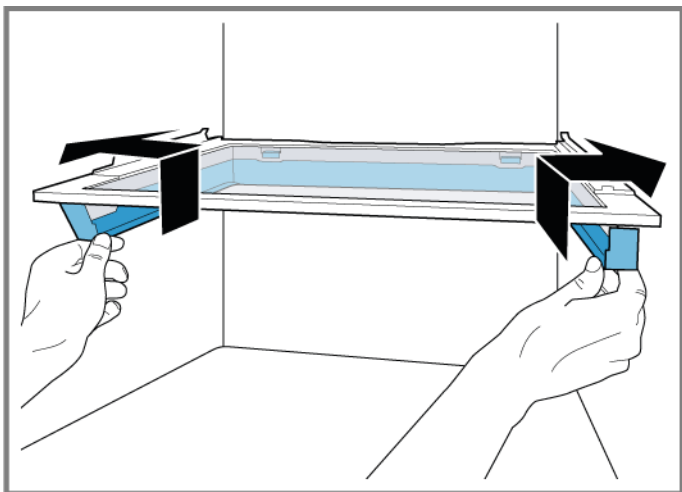

- ➡ Τα πλευρικά άγκιστρα απελευθερώνονται.

2. Σηκώστε προς τα επάνω το πλαίσιο στεγανοποίησης και σύρετέ το προς τα πίσω.

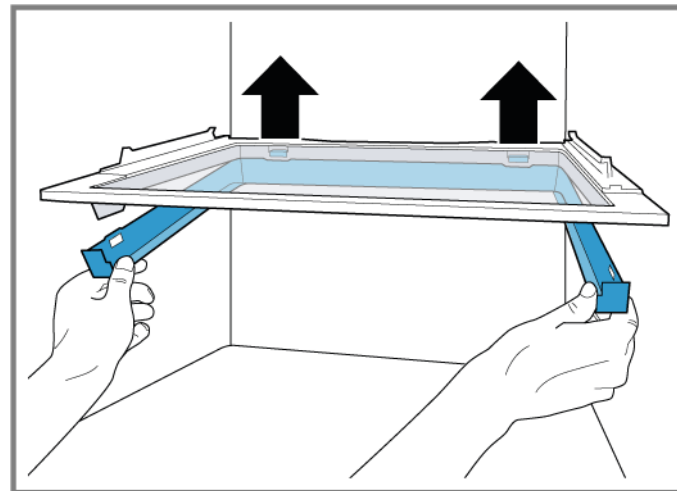

- ➡ Τα πίσω άγκιστρα απελευθερώνονται.

3. Αφαιρέστε το πλαίσιο στεγανοποίησης.
4. Σηκώστε επάνω το ράφι πάνω από το δοχείο φρούτων και λαχανικών και περιστρέψτε το στην άκρη για να το αφαιρέσετε.

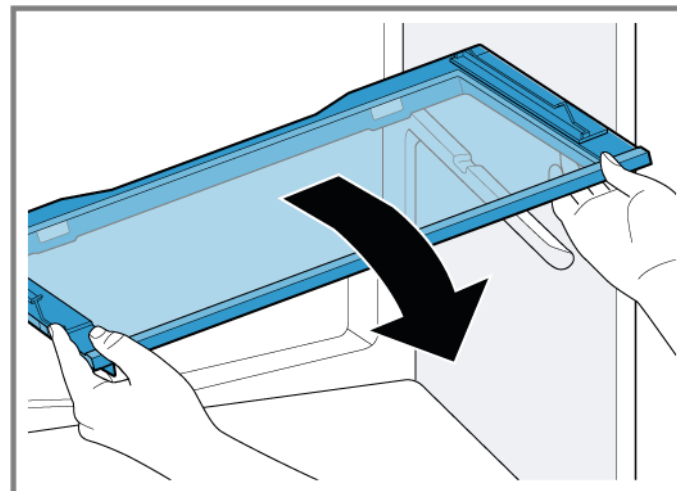

- ➡ Το ράφι εναπόθεσης πάνω από το δοχείο φρούτων και λαχανικών αφαιρέθηκε.

4.12.2 Τοποθέτηση ραφιού εναπόθεσης πάνω από το δοχείο φρούτων και λαχανικών

- ▶ Εγκαταστήστε με την αντίθετη σειρά.

4.13 Αντικατάσταση συρταριού κατεψυγμένων τροφίμων

Προϋπόθεση:

- ✔ Η πόρτα είναι ανοιχτή.

4.13.1 Αφαίρεση συρταριού κατεψυγμένων τροφίμων

- ▶ 1. Τραβήξτε προς τα έξω ολόκληρο το συρτάρι κατεψυγμένων τροφίμων (1).
- ▶ 2. Αφαιρέστε το συρτάρι τροφίμων (2).

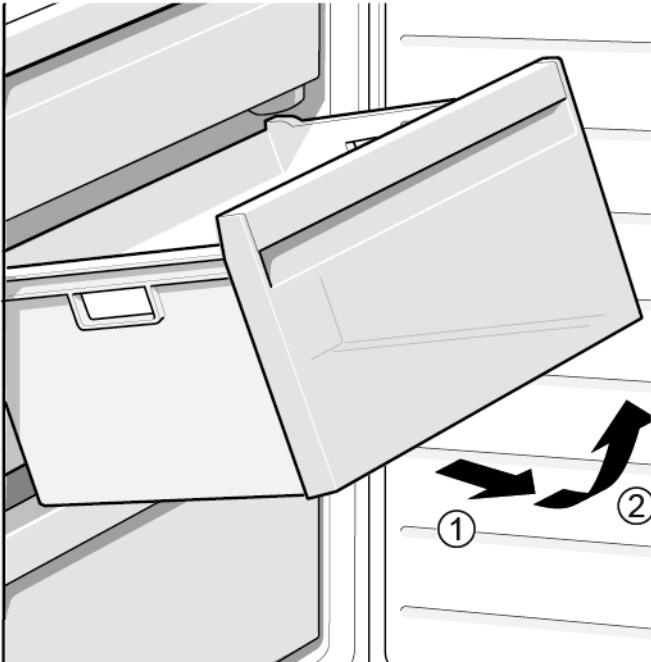

- ➡ Το συρτάρι κατεψυγμένων τροφίμων έχει αφαιρεθεί.

4.13.2 Τοποθέτηση συρταριού κατεψυγμένων τροφίμων

- ▶ Εγκαταστήστε με την αντίθετη σειρά.

4.14 Αντικατάσταση επάνω λυχνίας LED

Ειδικά βοηθητικά μέσα:

Ειδικό εργαλείο [00342180]



Η συσκευή διαθέτει ένα φως LED που δεν χρειάζεται συντήρηση. Αυτά τα φώτα μπορούν να επισκευαστούν μόνο από την εξυπηρέτηση πελατών ή από εξουσιοδοτημένους τεχνικούς!



ΚΙΝΔΥΝΟΣ

Κίνδυνος ηλεκτροπληξίας λόγω ηλεκτροφόρων μερών!

Κίνδυνος για τη ζωή από ηλεκτροπληξία σε περίπτωση ακατάλληλης επισκευής

- ▶ Τα ηλεκτρικά μέρη πρέπει να επισκευάζονται από εκπαιδευμένους ηλεκτρολόγους.
- ▶ Μετά την επισκευή πραγματοποιήστε έλεγχο ασφάλειας σύμφωνα με το VDE 0701 ή κανονισμούς της συγκεκριμένης χώρας.



ΚΙΝΔΥΝΟΣ

Κίνδυνος ηλεκτροπληξίας λόγω ηλεκτροφόρων μερών!

Θάνατος από ηλεκτροπληξία

- ▶ Αποσυνδέετε τις συσκευές από την παροχή ηλεκτρικού ρεύματος τουλάχιστον 60 δευτερόλεπτα πριν ξεκινήσετε τις επισκευές.



ΠΡΟΣΟΧΗ

Αιχμηρές ακμές!

Τραυματισμοί από κοπή

- ▶ Φοράτε προστατευτικά γάντια.

Προϋπόθεση:

- ✔ Η συσκευή είναι αποσυνδεδεμένη από την παροχή τροφοδοσίας.
- ✔ Η πόρτα είναι ανοιχτή.

4.14.1 Αφαίρεση επάνω λυχνίας LED

1. Σύρετε το εργαλείο αποσυναρμολόγησης μεταξύ της άνω λυχνίας LED και της εσωτερικής επένδυσης του συγκροτήματος ψυγείου για να απελευθερώσετε τα άγκιστρα της λυχνίας (1).
2. Αφαιρέστε την επάνω λυχνία LED (2).

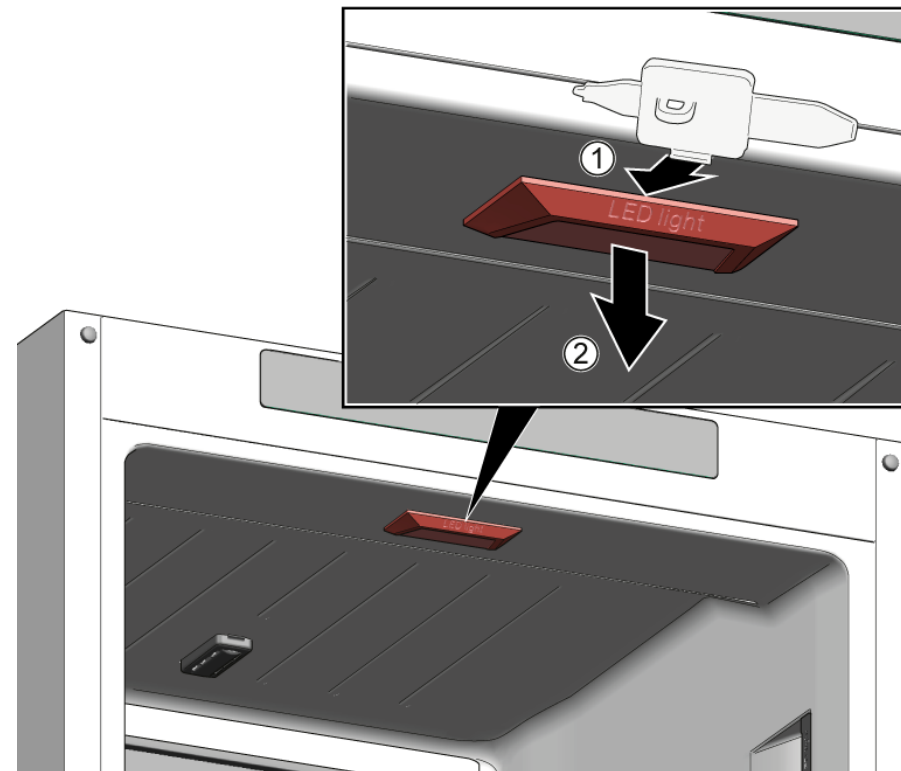

2. Αποσυνδέστε την ηλεκτρική σύνδεση της επάνω λυχνίας LED.
- ➡ Η επάνω λυχνία LED αφαιρέθηκε.

4.14.2 Τοποθέτηση επάνω λυχνίας LED



- ▶ Εγκαταστήστε με την αντίθετη σειρά.

4.15 Αντικατάσταση πλευρικής λυχνίας LED



Ειδικά βοηθητικά μέσα:

 Ειδικό εργαλείο [00342180]

	Η συσκευή διαθέτει ένα φως LED που δεν χρειάζεται συντήρηση. Αυτά τα φώτα μπορούν να επισκευαστούν μόνο από την εξυπηρέτηση πελατών ή από εξουσιοδοτημένους τεχνικούς!
---	---



	 ΚΙΝΔΥΝΟΣ Κίνδυνος ηλεκτροπληξίας λόγω ηλεκτροφόρων μερών! Κίνδυνος για τη ζωή από ηλεκτροπληξία σε περίπτωση ακατάλληλης επισκευής <ul style="list-style-type: none">▶ Τα ηλεκτρικά μέρη πρέπει να επισκευάζονται από εκπαιδευμένους ηλεκτρολόγους.▶ Μετά την επισκευή πραγματοποιήστε έλεγχο ασφάλειας σύμφωνα με το VDE 0701 ή κανονισμούς της συγκεκριμένης χώρας.
--	--

	 ΚΙΝΔΥΝΟΣ Κίνδυνος ηλεκτροπληξίας λόγω ηλεκτροφόρων μερών! Θάνατος από ηλεκτροπληξία <ul style="list-style-type: none">▶ Αποσυνδέετε τις συσκευές από την παροχή ηλεκτρικού ρεύματος τουλάχιστον 60 δευτερόλεπτα πριν ξεκινήσετε τις επισκευές.
--	--

	 ΠΡΟΣΟΧΗ Αιχμηρές ακμές! Τραυματισμοί από κοπή <ul style="list-style-type: none">▶ Φοράτε προστατευτικά γάντια.
---	--

	ΠΡΟΣΟΧΗ! Κίνδυνος πρόκλησης βλάβης σε μέρη ευαίσθητα στον στατικό ηλεκτρισμό (ESDs)! Ζημιά στοιχείων <ul style="list-style-type: none">▶ Πριν αγγίξετε εξαρτήματα ευαίσθητα στον στατικό ηλεκτρισμό (eSDS) χρησιμοποιήστε ένα σύστημα ηλεκτροστατικής προστασίας (βραχιολάκι ασφαλείας και σύνδεση με τη γη).▶ Μην αγγίζετε τις συνδέσεις και τους αγωγούς των πλακετών.▶ Κατά την μεταφορά εξαρτημάτων ευαίσθητα στον στατικό ηλεκτρισμό (ESDs) ή αγωγίμων υλικών θα πρέπει να μεταφέρονται στην αρχική τους συσκευασία.▶ Κρατήστε τα εξαρτήματα ευαίσθητα στον στατικό ηλεκτρισμό (ESDs) μακριά από ηλεκτροστατικά φορτισμένα υλικά (π.χ. πλαστικά).
---	---

Προϋπόθεση:

-  Η συσκευή είναι αποσυνδεδεμένη από την παροχή τροφοδοσίας.
-  Η πόρτα είναι ανοιχτή.
-  Αφαιρέθηκαν τα εσωτερικά εξαρτήματα RC.

4.15.1 Αφαίρεση πλευρικής λυχνίας LED

1. Σύρετε το εργαλείο αποσυναρμολόγησης μεταξύ της διάταξης διάχυσης λυχνίας και του περιβλήματος για να απελευθερώσετε το άγκιστρο (1).
2. Μετακινήστε προς τα έξω τη διάταξη διάχυσης της λυχνίας (2).
3. Απελευθερώστε τα ακόλουθα άγκιστρα στερέωσης της διάταξης διάχυσης κατά τον ίδιο τρόπο.

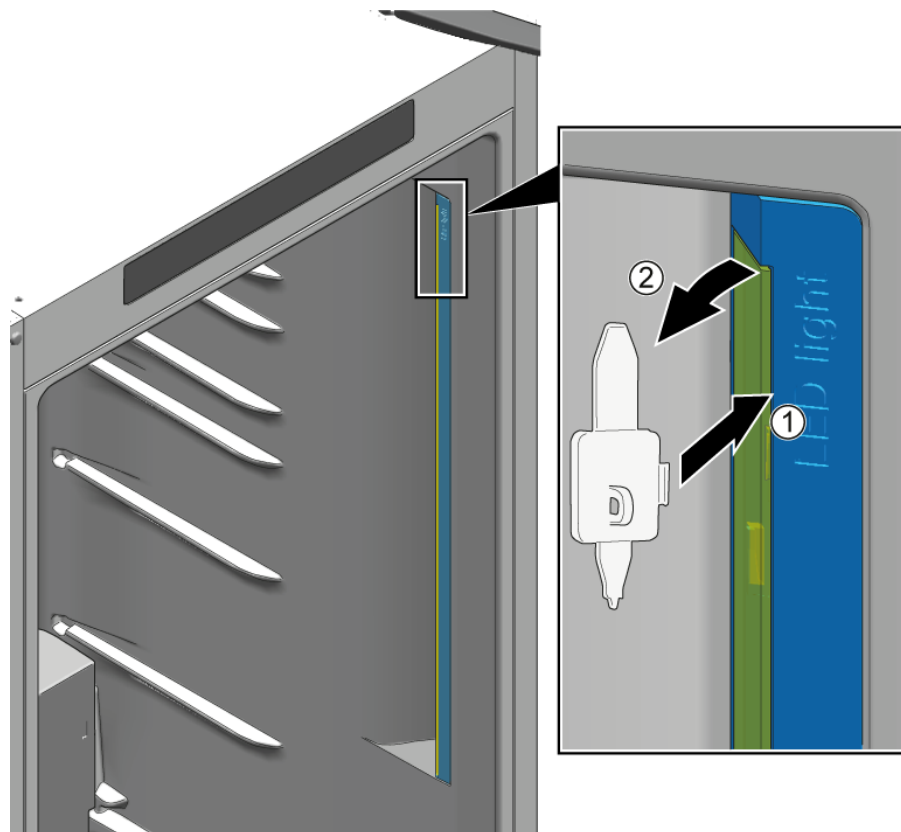

➡ Η διάταξη διάχυσης της λυχνίας αφαιρέθηκε.

2. 1. Πατήστε το άγκιστρο στερέωσης για να το απελευθερώσετε (1).
2. Μετακινήστε τη μονάδα LED περ. 1 cm προς τα επάνω για αφαίρεση για να την αποσυνδέσετε από την ηλεκτρική πρίζα (2).
3. Αφαιρέστε τη μονάδα LED (3).

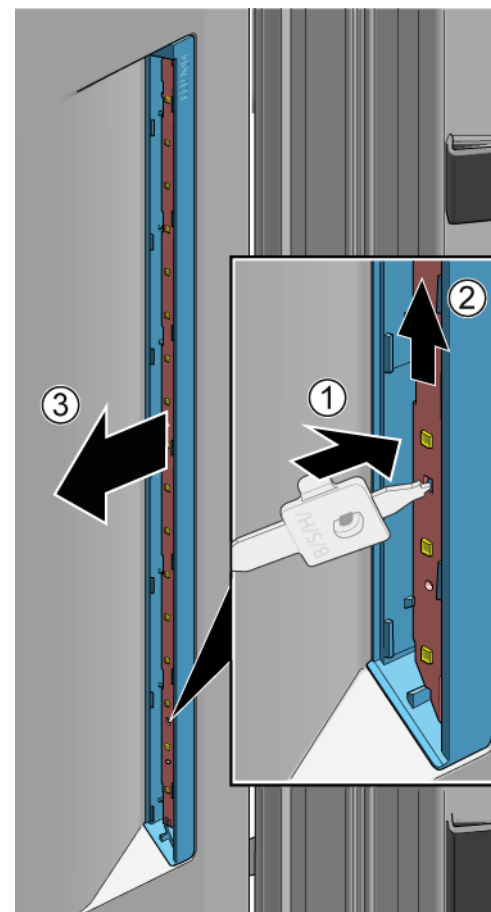

➡ Η πλευρική λυχνία LED αφαιρέθηκε.

4.15.2 Τοποθέτηση πλευρικής λυχνίας LED



Επειδή τα άγκιστρα της διάταξης διάχυσης της λυχνίας είναι εύκολο να σπάσουν κατά τη διαδικασία αφαίρεσης, η ανταλλακτική πλευρική λυχνία LED είναι το σετ που περιλαμβάνει τη μονάδα LED και τη διάταξη διάχυσης της λυχνίας.

ΕΠΙΣΚΕΥΗ

1. Σύρετε το εργαλείο αποσυναρμολόγησης μεταξύ της διάταξης διάχυσης λυχνίας και του περιβλήματος για να απελευθερώσετε το άγκιστρο (1).
2. Μετακινήστε προς τα έξω τη διάταξη διάχυσης της λυχνίας (2).
3. Απελευθερώστε τα ακόλουθα άγκιστρα στερέωσης της διάταξης διάχυσης κατά τον ίδιο τρόπο.

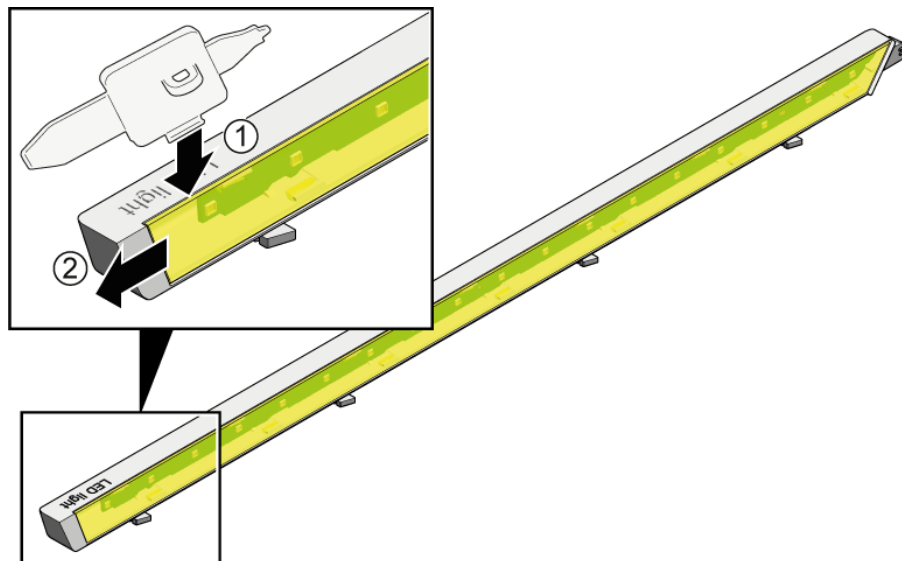

2. 1. Πατήστε το άγκιστρο στερέωσης για να το απελευθερώσετε (1).
2. Σύρετε τη μονάδα LED προς τα επάνω και έξω από το περίβλημα.
3. Αποθέστε το περίβλημα μονάδας LED που χρησιμοποιείται για λόγους ασφάλειας μεταφοράς ανταλλακτικών (3).

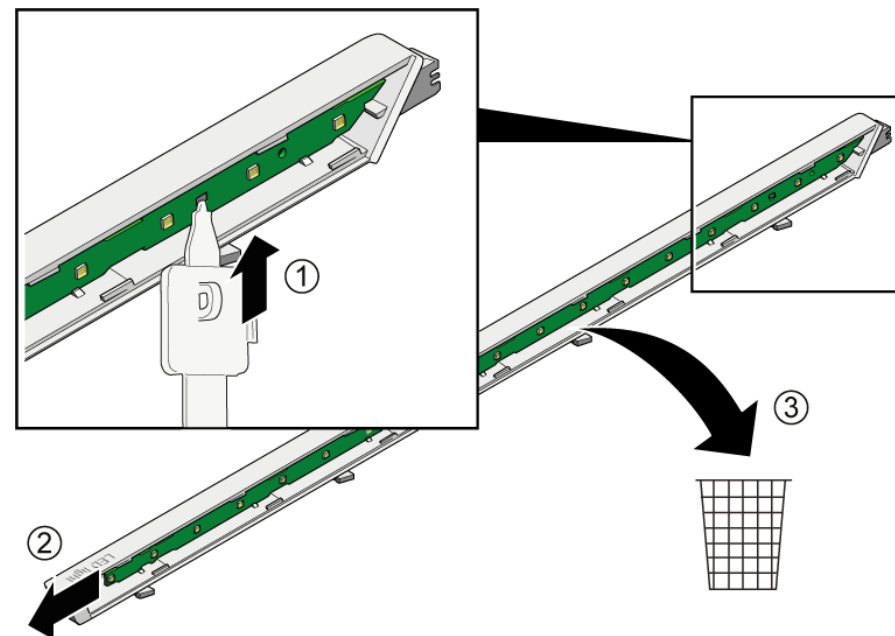



3. Εγκαταστήστε τη μονάδα LED και τη διάταξη διάχυσης της λυχνίας στην αντίστροφη σειρά για αφαίρεση.

4.16 Αντικατάσταση λυχνίας LED καταψύκτη

Ειδικά βοηθητικά μέσα:

 Ειδικό εργαλείο [00342180]

 Η συσκευή διαθέτει ένα φως LED που δεν χρειάζεται συντήρηση. Αυτά τα φώτα μπορούν να επισκευαστούν μόνο από την εξυπηρέτηση πελατών ή από εξουσιοδοτημένους τεχνικούς!

 **ΚΙΝΔΥΝΟΣ**
Κίνδυνος ηλεκτροπληξίας λόγω ηλεκτροφόρων μερών!
 Κίνδυνος για τη ζωή από ηλεκτροπληξία σε περίπτωση ακατάλληλης επισκευής

- ▶ Τα ηλεκτρικά μέρη πρέπει να επισκευάζονται από εκπαιδευμένους ηλεκτρολόγους.
- ▶ Μετά την επισκευή πραγματοποιήστε έλεγχο ασφάλειας σύμφωνα με το VDE 0701 ή κανονισμούς της συγκεκριμένης χώρας.



 **ΚΙΝΔΥΝΟΣ**
Κίνδυνος ηλεκτροπληξίας λόγω ηλεκτροφόρων μερών!
 Θάνατος από ηλεκτροπληξία

- ▶ Αποσυνδέετε τις συσκευές από την παροχή ηλεκτρικού ρεύματος τουλάχιστον 60 δευτερόλεπτα πριν ξεκινήσετε τις επισκευές.

 **ΠΡΟΣΟΧΗ**
Αιχμηρές ακμές!
 Τραυματισμοί από κοπή

- ▶ Φοράτε προστατευτικά γάντια.



Προϋπόθεση:

-  Η συσκευή είναι αποσυνδεδεμένη από την παροχή τροφοδοσίας.
-  Η πόρτα είναι ανοιχτή.

4.16.1 Αφαίρεση λυχνίας LED καταψύκτη

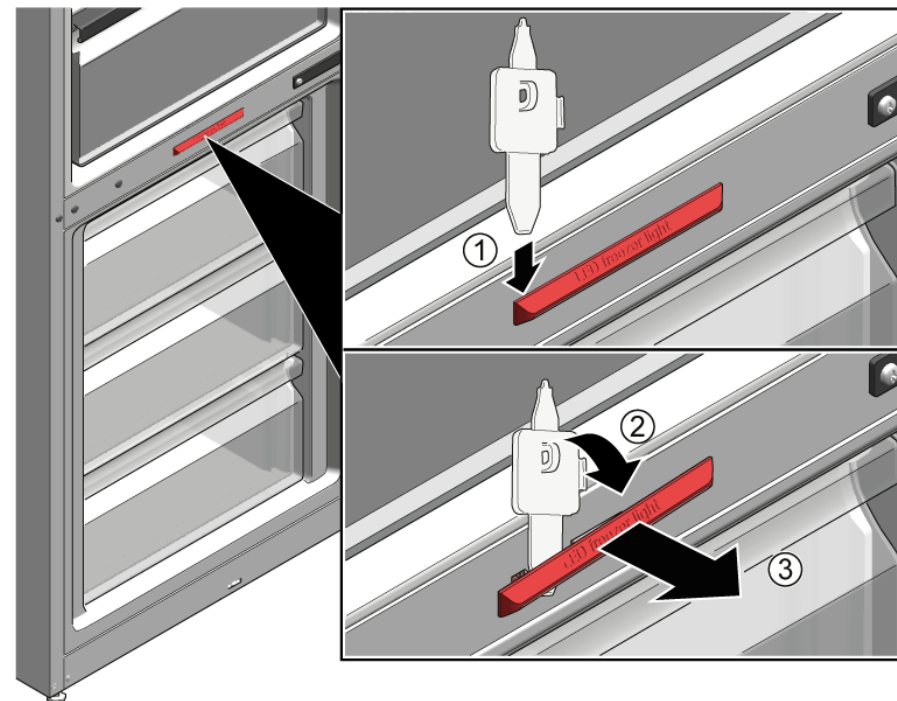
- ▶ 1. Σύρετε το εργαλείο αποσυναρμολόγησης μεταξύ της λυχνίας και του περιβλήματος πλευρικά της λυχνίας για να δημιουργηθεί κενό (1).
- ▶ 2. Σύρετε το εργαλείο αποσυναρμολόγησης στην άλλη πλευρά του άγκιστρου στερέωσης της λυχνίας και περιστρέψτε το προς τα εμπρός (2).
- ▶ 3. Αφαιρέστε τη λυχνία LED καταψύκτη (3).







-  Η λυχνία LED καταψύκτη αποσυνδέθηκε.
-  Η λυχνία LED καταψύκτη αφαιρέθηκε.

4.16.2 Τοποθέτηση λυχνίας LED καταψύκτη

- ▶ Εγκαταστήστε με την αντίθετη σειρά.

Javítási útmutató - Hűtő-/fagyasztó-kombináció

 A dokumentummal kapcsolatos információk.....	330
1.1 Fontos tudnivalók	330
1.1.1 Cél	330
1.2 Szimbólummagyarázat	330
1.2.1 Veszélyességi szintek	330
1.2.2 Veszélyt jelző szimbólumok	330
1.2.3 A figyelmeztetések felépítése	331
1.2.4 Általános szimbólumok.....	331
 Biztonság	332
2.1 Általános biztonsági utasítások.....	332
2.1.1 Összes háztartási készülék	332
 Szerszámok és segédanyagok.....	333
 Javítás	334
4.1 A gumitömítés cseréje	334
4.1.1 A gumitömítés eltávolítása.....	334
4.1.2 A gumitömítés beszerelése.....	334
4.2 A fogantyú cseréje.....	337
4.2.1 A fogantyú eltávolítása	337
4.2.2 A fogantyú felszerelése	337
4.3 A felső ajtózsanér cseréje	338
4.3.1 A felső ajtózsanér eltávolítása.....	338
4.3.2 A felső ajtózsanér felhelyezése	339
4.4 A felső ajtózsanér cseréje (kijelzős ajtó).....	340
4.4.1 A felső ajtózsanér eltávolítása.....	341
4.4.2 A felső ajtózsanér felhelyezése	342
4.5 A középső ajtózsanér cseréje.....	343
4.5.1 A középső ajtózsanér eltávolítása	343
4.5.2 A középső ajtózsanér felhelyezése	344
4.6 Az alsó ajtózsanér cseréje	345
4.6.1 Az alsó ajtózsanér eltávolítása	345
4.6.2 Az alsó ajtózsanér felhelyezése	345
4.7 A polc cseréje	346
4.7.1 A polc eltávolítása	346
4.7.2 A polc beszerelése.....	346

4.8 A palacktartó cseréje.....	347
4.8.1 A palacktartó eltávolítása	347
4.8.2 A palacktartó telepítése	347
4.9 Az ajtópolc cseréje	348
4.9.1 Az ajtópolc eltávolítása	348
4.9.2 Az ajtópolc felhelyezése.....	348
4.10 Tárolótartály cseréje.....	349
4.10.1 Tárolótartály eltávolítása	349
4.10.2 A tárolótartály behelyezése	349
4.11 A gyümölcs- és zöldségtároló cseréje	350
4.11.1 A gyümölcs- és zöldségtároló eltávolítása.....	350
4.11.2 A gyümölcs- és zöldségtároló behelyezése	350
4.12 A gyümölcs- és zöldségtároló feletti polc cseréje	351
4.12.1 A gyümölcs- és zöldségtároló feletti polc eltávolítása.....	351
4.12.2 A gyümölcs- és zöldségtároló feletti polc behelyezése	352
4.13 Fagyasztódoboz cseréje.....	353
4.13.1 Fagyasztódoboz eltávolítása	353
4.13.2 A fagyasztódoboz behelyezése	353
4.14 A felső LED-es lámpa cseréje.....	354
4.14.1 A felső LED-es lámpa eltávolítása	354
4.14.2 A felső LED-es lámpa beszerelése	354
4.15 Az oldalsó LED-es lámpa cseréje.....	355
4.15.1 Az oldalsó LED-es lámpa eltávolítása	355
4.15.2 Az oldalsó LED-es lámpa beszerelése	356
4.16 A fagyasztó LED-es lámpájának cseréje.....	358
4.16.1 A fagyasztó LED-es lámpájának eltávolítása	358
4.16.2 A fagyasztó LED-es lámpájának beszerelése	358

i A dokumentummal kapcsolatos információk

1.1 Fontos tudnivalók

1.1.1 Cél

Ezek a javítási tanácsok támogatják a fogyasztót a készülékek otthoni megjavításában a környezettudatos tervezésről szóló rendeletnek (2021 márciusától alkalmazandó) megfelelően.



Információkat tartalmaznak bizonyos pótalkatrészek cseréjével kapcsolatban, ideértve a figyelmeztetéseket és a kockázatokat is.

Ha kérdése van, vegye fel a kapcsolatot a vevőszolgálattal. A károkért kizárólag akkor vállalunk felelősséget, ha a javítási tanácsokat pontosan betartották.

1.2 Szimbólummagyarázat

1.2.1 Veszélyességi szintek

A veszélyességi szintek egy szimbólumból és egy figyelmeztető mondatból állnak. A figyelmeztető mondat utal a veszély súlyosságára.





Veszélyességi szint	Jelentés
 VESZÉLY	A figyelmeztető üzenet figyelmen kívül hagyása halált vagy súlyos sérüléseket okoz.
 FIGYELMEZTETÉS	A figyelmeztető üzenet figyelmen kívül hagyása halált vagy súlyos sérüléseket okozhat.
 VIGYÁZAT	A figyelmeztető üzenet figyelmen kívül hagyása kisebb sérüléseket okozhat.
FIGYELEM!	A figyelmeztető üzenet figyelmen kívül hagyása anyagi károkat okozhat.

Táblázat 1: Veszélyességi szintek

1.2.2 Veszélyt jelző szimbólumok

A veszélyt jelző szimbólumok a veszélyt ábrázoló szimbolikus ábrázolások.

A jelen dokumentumban az alábbi veszélyt jelző szimbólumok használatosak:

Veszélyt jelző szimbólum	Jelentés
	Általános figyelmeztető üzenet
	Elektromos feszültség veszélye
	Robbanásveszély
	Vágásveszély
	Zúzódásveszély

i A dokumentummal kapcsolatos információk

Veszélyt jelző szimbólum	Jelentés
	Forró felületek miatt fennálló veszély
	Erős mágneses mező miatt fennálló veszély
	Nem ionizáló sugárzás veszélye

Táblázat 2: Veszélyt jelző szimbólumok

1.2.3 A figyelmeztetések felépítése

A jelen dokumentumban lévő figyelmeztetések szabványosított megjelenésűek és felépítésűek.

	<p>⚠ VESZÉLY</p> <p>A veszély típusa és forrása! A veszély / figyelmeztetés figyelmen kívül hagyásának lehetséges következményei.</p> <ul style="list-style-type: none"> ▶ A veszély megelőzésére szolgáló intézkedések és tiltások.
--	---

Az alábbi példa egy olyan figyelmeztetést mutat be, amely az áram alatt lévő alkatrészek okozta áramütésre figyelmeztet. Megemlíti a veszély elkerülésére szolgáló intézkedést.

	<p>⚠ VESZÉLY</p> <p>Áramütés veszélye áram alatt lévő alkatrészek miatt! Halálos áramütés</p> <ul style="list-style-type: none"> ▶ A javítás megkezdése előtt legalább 60 másodperccel válassza le a készülékeket az elektromos hálózatról.
--	--

1.2.4 Általános szimbólumok

A jelen dokumentumban az alábbi általános szimbólumok használatosak:

Ált. szimbólum	Jelentés
	Különleges tanács (szöveg és/vagy grafika)

Ált. szimbólum	Jelentés
	Egyszerű tanács (csak szöveg)
	Videós oktatóanyagra mutató hivatkozás
	A szükséges eszközök
	A szükséges feltételek
	Feltétel (ha..., akkor...)
	Eredmény
[Indítás]	Billentyű vagy gomb
[00123456]	Anyagszám azonosítója
Állapot	Megjelenített szöveg / ablak (a készülék kijelzőjén)

Táblázat 3: Általános szimbólumok

2.1 Általános biztonsági utasítások

2.1.1 Összes háztartási készülék

Áramütés veszélye áram alatt lévő alkatrészek miatt!

- Az elektromos alkatrészek hibás javítása áramütéshez vezethet!
- A javítás megkezdése előtt legalább 60 másodperccel válassza le a készüléket az elektromos hálózatról.
- A javítás után végeztesse a VDE 0701-nek vagy az országspecifikus szabályozásoknak megfelelő vizsgálatot.

Éles peremek miatt fennálló sérülésveszély!

- Viseljen védőkesztyűt.

Zúzódásveszély a javítás, karbantartás, hibaelhárítás és szervizelés során a nehéz és mozgó alkatrészek miatt

- Viseljen védőcipőt.
- Biztosítsa leesés ellen a nehéz alkatrészeket.
- Ne dugja be a testrészeit a mozgó alkatrészek közé.

Sérülhet a készülék biztonsága / működése!

- Kizárólag eredeti pótalkatrészeket használjon.

Elektrosztatikailag érzékeny alkatrészek (ESD-k) károsodásának veszélye!

- Ne érintse meg a modulokat, ideértve a csatlakozásokat és a vezetőket.

Szerszámok és segédanyagok

Kijelölés	Részletek	Képek
TX20 Torx bithegy [00340865]	6,3 mm (1/4")	
Különleges szer- szám [00342180]		

4.1 A gumitömítés cseréje

Követelmény:

- ✓ Az ajtó nyitva van

4.1.1 A gumitömítés eltávolítása

1. Vegye ki a gumitömítést a barázdából a jobb és a bal sarokban.



2. Húzza ki a gumitömítést a barázdából.

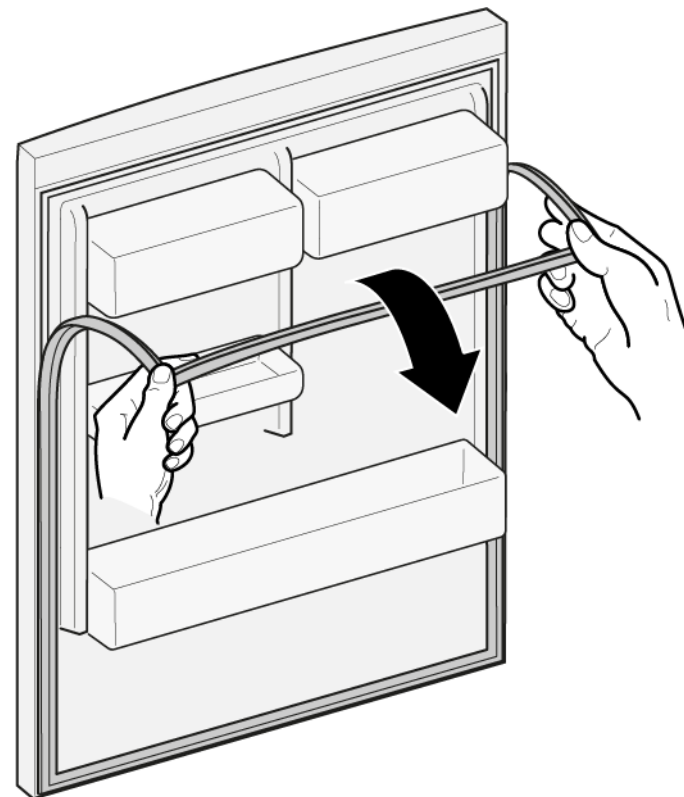

- ➡ Eltávolította a gumitömítést.

4.1.2 A gumitömítés beszerelése



Az új gumitömítés vastagsága enyhén eltérhet a régi gumitömítés vastagságától. Ez nem befolyásolja az ajtócsukás módját és hosszú távú működését.

Ha a készülékében beállítható zsanérok vagy zsanérrögítések vannak, utólag optimalizálhatja a becsukás módját.

A gumitömítésben lévő apró, oldalsó lyukak funkcionálisak (a szellőzéshez szükségesek). Ezek nem gyártási hibák.

1. Ellenőrizze a barázdát sérülések szempontjából.

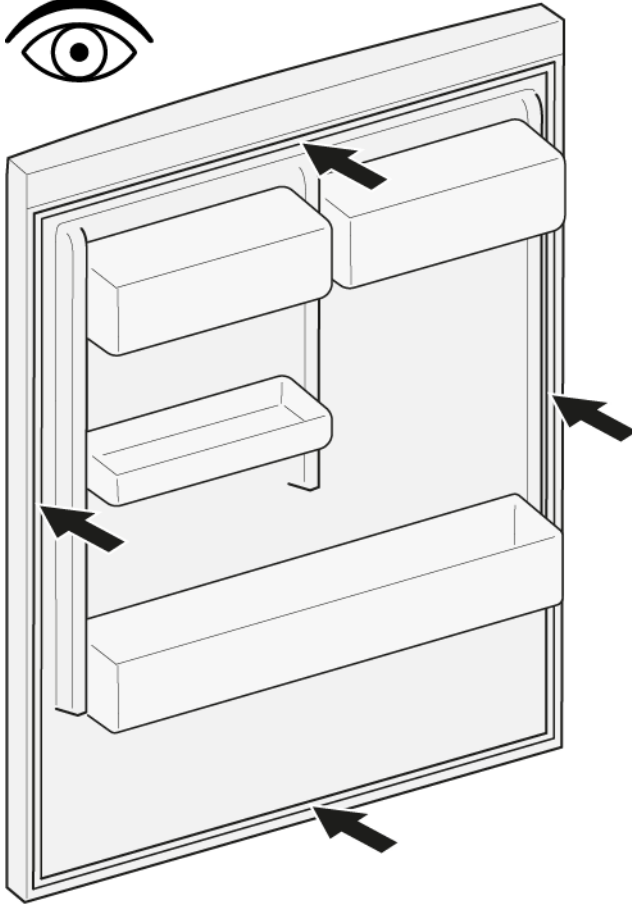

4. Nyomja a gumitömítés fenti és lenti sarkait a barázdába.

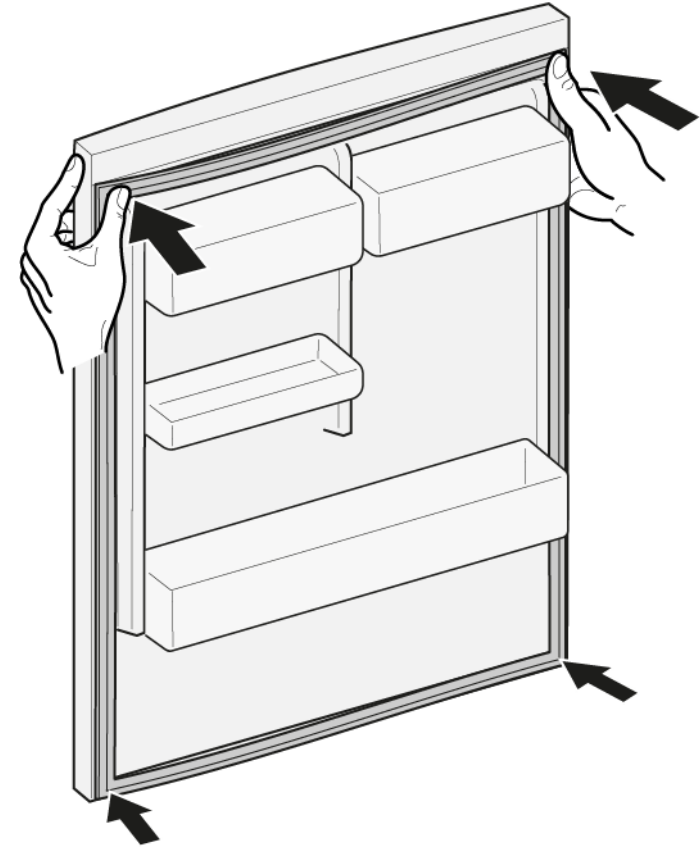



2. ⓘ Ha a gumitömítés barázdája sérült:
- Vegye fel a kapcsolatot az ügyfélszolgálattal.

3. ⓘ A gumitömítés enyhe deformálódása normális, és nem befolyásolja a működését. Javasolt a gumitömítés kiegyenesítése a készülékbe történő behelyezés előtt.

Hajszárítóval vagy forró vízzel melegítse fel a gumitömítést, és kézzel formázza újra.

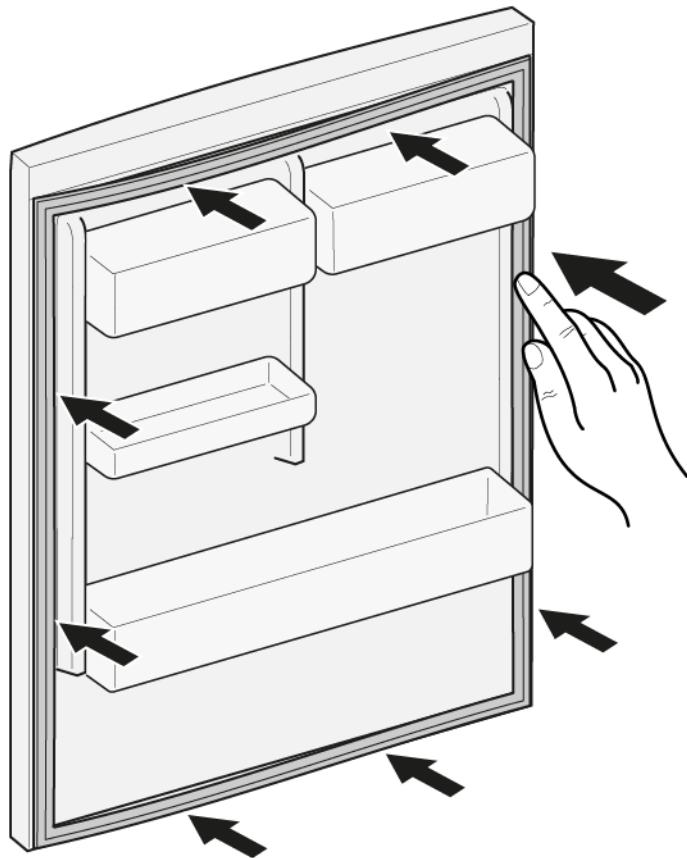
5. Nyomja a teljes gumitömítést apránként a barázdába.



-  Beszerelte a gumitömítést.

4.2 A fogantyú cseréje

Különleges eszközök

- TX20 Torx bithegy 6,3 mm (1/4") [00340865]
- Laposfejű csavarhúzó Hegy 10 mm x 1,6 mm x 200 mm

Követelmény:

- ✓ A készüléket leválasztotta az áramellátásról.
- ✓ Az ajtó nyitva van

4.2.1 A fogantyú eltávolítása

- ▶ 1. Távolítsa el a két csavarfedelelet (1).
- ▶ 2. Csavarja ki a két csavart (2).
- ▶ 3. Távolítsa el a fogantyút (3).

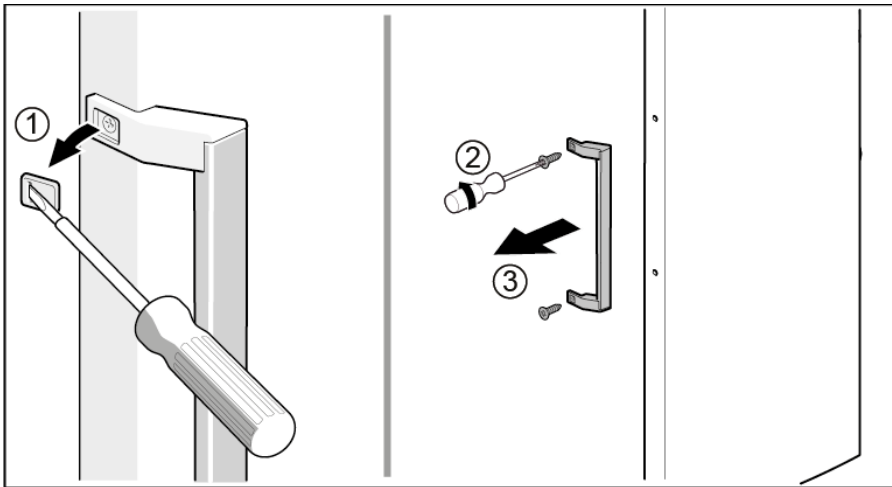

➔ Eltávolította a fogantyút.



A második ajtó fogantyújának eltávolítása ugyanígy történik.

4.2.2 A fogantyú felszerelése

- ▶ Az elhelyezést fordított sorrendben végezze.

4.3 A felső ajtózsanér cseréje

Különleges eszközök

 TX20 Torx bithegy

6,3 mm (1/4")

[00340865]

	⚠ FIGYELMEZTETÉS
<p>Nehéz, nagy készülékek! Hát- és izomsérülések</p> <ul style="list-style-type: none"> ▶ A készülék ajtajának eltávolítását kizárólag szakemberrel végeztesse. ▶ A készülék elmozdításához két emberre van szükség. ▶ Kizárólag megfelelő eszközöket és berendezéseket használjon. 	



	⚠ VIGYÁZAT
<p>Éles szélek! Vágási sérülések</p> <ul style="list-style-type: none"> ▶ Viseljen védőkesztyűt. 	

	⚠ FIGYELMEZTETÉS
<p>Megdöntött készülékek elcsúszása! Csonttörés / zúzódási sérülések</p> <ul style="list-style-type: none"> ▶ Biztosítsa a készülékeket elcsúszás ellen. 	

	⚠ VIGYÁZAT
<p>Leeső alkatrészek veszélye a kioldott csavarok miatt! Leeső alkatrészek miatti sérülés.</p> <ul style="list-style-type: none"> ▶ Biztosítsa az alkatrészt leesés ellen. 	

	FIGYELEM!
<p>Leeső alkatrészek veszélye a kioldott csavarok miatt! A készülék többi részeinek vagy az ügyfél lakásának (pl. padló) károsodása.</p> <ul style="list-style-type: none"> ▶ Biztosítsa az alkatrészt leesés ellen. 	

Követelmény:

-  A készüléket leválasztotta az áramellátásról.
-  Eltávolította a készülék belső szerelvényeit.

4.3.1 A felső ajtózsanér eltávolítása

1. Csúsztassa a támasztékot az alaplap alá.

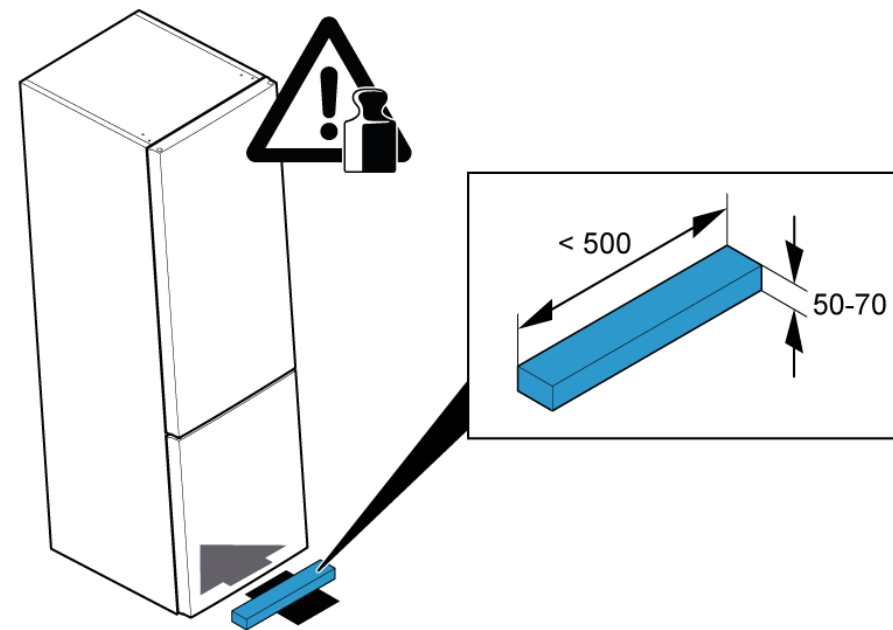

2. 1. Távolítsa el a felső zsanér burkolatát (1).
2. Csavarja ki mindkét csavart (2).
3. Távolítsa el a felső zsanért (3).

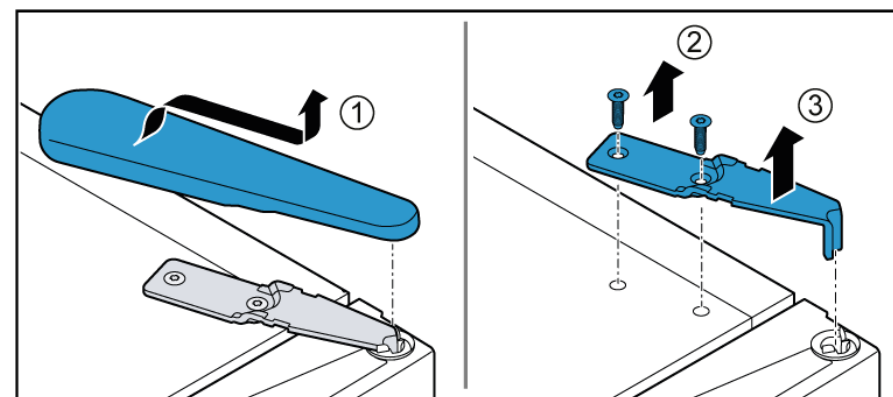

3. Vegye le a felső ajtót.

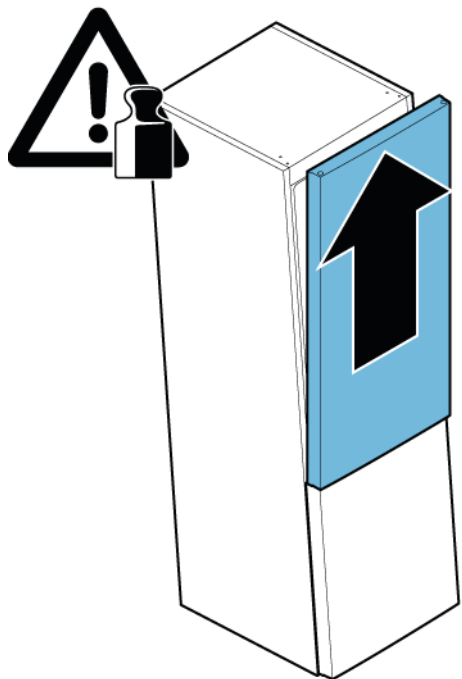

 Eltávolította a felső zsanért.

4.3.2 A felső ajtózsanér felhelyezése

▶ Az elhelyezést fordított sorrendben végezze.

4.4 A felső ajtózsanér cseréje (kijelzős ajtó)

Különleges eszközök

 TX20 Torx bithegy 6,3 mm (1/4") [00340865]

	⚠ FIGYELMEZTETÉS
	<p>Nehéz, nagy készülékek! Hát- és izomsérülések</p> <ul style="list-style-type: none"> ▶ A készülék ajtajának eltávolítását kizárólag szakemberrel végeztesse. ▶ A készülék elmozdításához két emberre van szükség. ▶ Kizárólag megfelelő eszközöket és berendezéseket használjon.

	⚠ VIGYÁZAT
	<p>Éles szélek! Vágási sérülések</p> <ul style="list-style-type: none"> ▶ Viseljen védőkesztyűt.

	⚠ FIGYELMEZTETÉS
	<p>Megdöntött készülékek elcsúszása! Csonttörés / zúzódási sérülések</p> <ul style="list-style-type: none"> ▶ Biztosítsa a készülékeket elcsúszás ellen.



	⚠ VIGYÁZAT
	<p>Leeső alkatrészek veszélye a kioldott csavarok miatt! Leeső alkatrészek miatti sérülés.</p> <ul style="list-style-type: none"> ▶ Biztosítsa az alkatrészt leesés ellen.

	FIGYELEM!
	<p>Leeső alkatrészek veszélye a kioldott csavarok miatt! A készülék többi részeinek vagy az ügyfél lakásának (pl. padló) károsodása.</p> <ul style="list-style-type: none"> ▶ Biztosítsa az alkatrészt leesés ellen.

	⚠ VESZÉLY
	<p>Áramütés veszélye áram alatt lévő alkatrészek miatt! Életveszély a nem megfelelő javítás okozta áramütés miatt</p> <ul style="list-style-type: none"> ▶ Az elektromos alkatrészek javítását kizárólag képzett elektroműszerész végezheti. ▶ A javítás után végeztesse a VDE 0701-nek vagy az országspecifikus szabályozásoknak megfelelő vizsgálatot.

	⚠ VESZÉLY
	<p>Áramütés veszélye áram alatt lévő alkatrészek miatt! Halálos áramütés</p> <ul style="list-style-type: none"> ▶ A javítás megkezdése előtt legalább 60 másodperccel válassza le a készülékeket az elektromos hálózatról.

Követelmény:

-  A készüléket leválasztotta az áramellátásról.
-  Eltávolította a készülék belső szerelvényeit.

4.4.1 A felső ajtózanér eltávolítása

1. Csúsztassa a támasztékot az alaplap alá.

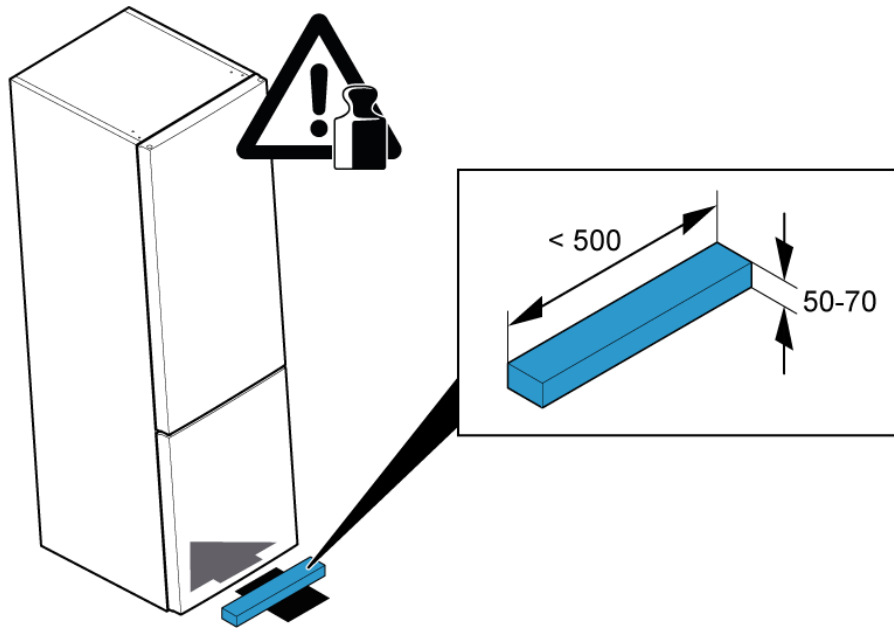

2. 1. Távolítsa el a felső zsanér burkolatát (1).
2. Válassza le az elektromos csatlakozást (2).
3. Csavarja ki a földelő csatlakozás csavarját (3).

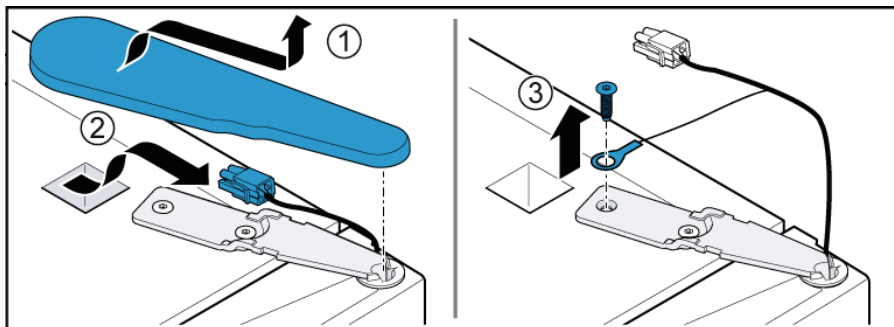

3. 1. Csavarja ki a csavart (1).
2. Távolítsa el a felső zsanért (2).

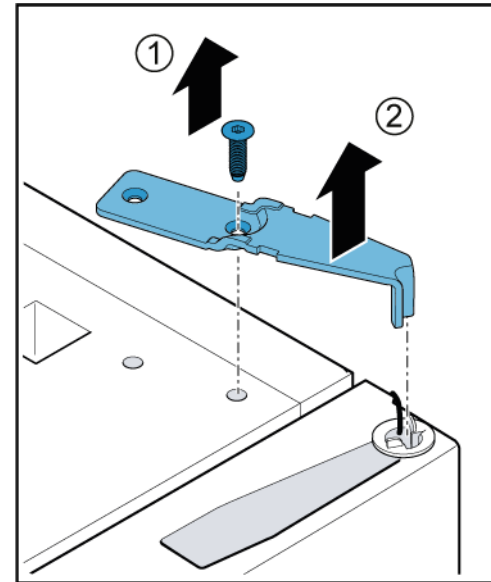

4. Vegye le a felső ajtót.

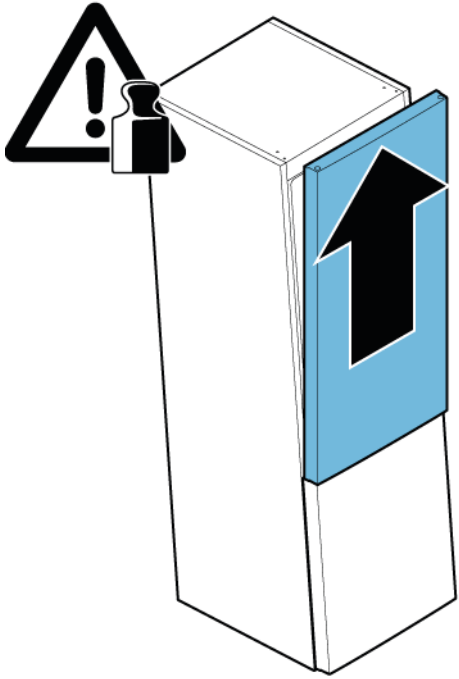

 Eltávolította a felső zsanért.

4.4.2 A felső ajtózsanér felhelyezése

- ▶ Az elhelyezést fordított sorrendben végezze.

4.5 A középső ajtózanér cseréje

Különleges eszközök

TX20 Torx bithegy

6,3 mm (1/4")

[00340865]

	⚠ FIGYELMEZTETÉS
	<p>Nehéz, nagy készülékek! Hát- és izomsérülések</p> <ul style="list-style-type: none"> ▶ A készülék ajtajának eltávolítását kizárólag szakemberrel végeztesse. ▶ A készülék elmozdításához két emberre van szükség. ▶ Kizárólag megfelelő eszközöket és berendezéseket használjon.

	⚠ VIGYÁZAT
	<p>Éles szélek! Vágási sérülések</p> <ul style="list-style-type: none"> ▶ Viseljen védőkesztyűt.

	⚠ FIGYELMEZTETÉS
	<p>Megdöntött készülékek elcsúszása! Csonttörés / zúzódási sérülések</p> <ul style="list-style-type: none"> ▶ Biztosítsa a készülékeket elcsúszás ellen.

	⚠ VIGYÁZAT
	<p>Leeső alkatrészek veszélye a kioldott csavarok miatt! Leeső alkatrészek miatti sérülés.</p> <ul style="list-style-type: none"> ▶ Biztosítsa az alkatrészt leesés ellen.

	FIGYELEM!
	<p>Leeső alkatrészek veszélye a kioldott csavarok miatt! A készülék többi részeinek vagy az ügyfél lakásának (pl. padló) károsodása.</p> <ul style="list-style-type: none"> ▶ Biztosítsa az alkatrészt leesés ellen.

Követelmény:

- ✓ A készüléket leválasztotta az áramellátásról.
- ✓ Eltávolította a készülék belső szerelvényeit.
- ✓ Eltávolította az ajtó felső zsanérját.

- ✓ Eltávolította a felső ajtót.

4.5.1 A középső ajtózanér eltávolítása

1. 1. Csavarja ki mindkét csavart (1).
2. 2. Távolítsa el a középső zsanért (2).

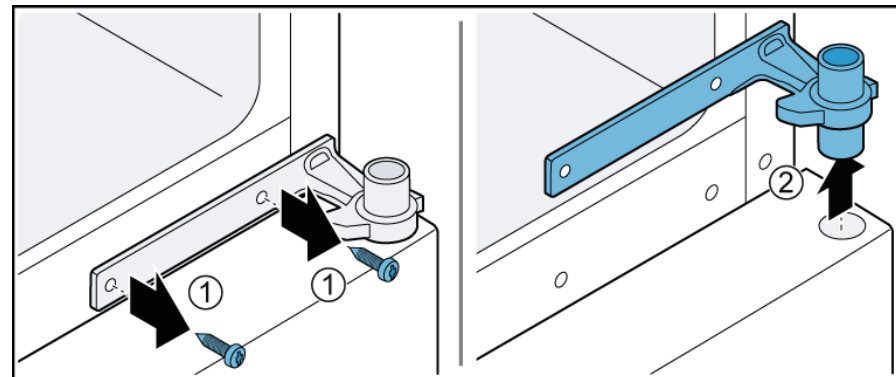

2. Vegye le az alsó ajtót.

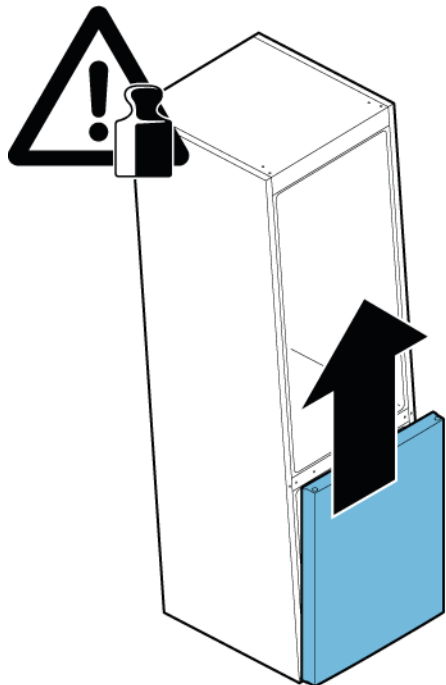

 Eltávolította a középső zsanért.

4.5.2 A középső ajtózsanér felhelyezése

▶ Az elhelyezést fordított sorrendben végezze.

4.6 Az alsó ajtózanér cseréje

Különleges eszközök

TX20 Torx bithegy

6,3 mm (1/4")

[00340865]

	FIGYELMEZTETÉS
	<p>Nehéz, nagy készülékek! Hát- és izomsérülések</p> <ul style="list-style-type: none"> ▶ A készülék ajtajának eltávolítását kizárólag szakemberrel végeztesse. ▶ A készülék elmozdításához két emberre van szükség. ▶ Kizárólag megfelelő eszközöket és berendezéseket használjon.

	VIGYÁZAT
	<p>Éles szélek! Vágási sérülések</p> <ul style="list-style-type: none"> ▶ Viseljen védőkesztyűt.

	FIGYELMEZTETÉS
	<p>Megdöntött készülékek elcsúszása! Csonttörés / zúzódási sérülések</p> <ul style="list-style-type: none"> ▶ Biztosítsa a készülékeket elcsúszás ellen.

	VIGYÁZAT
	<p>Leeső alkatrészek veszélye a kioldott csavarok miatt! Leeső alkatrészek miatti sérülés.</p> <ul style="list-style-type: none"> ▶ Biztosítsa az alkatrészt leesés ellen.

	FIGYELEM!
	<p>Leeső alkatrészek veszélye a kioldott csavarok miatt! A készülék többi részeinek vagy az ügyfél lakásának (pl. padló) károsodása.</p> <ul style="list-style-type: none"> ▶ Biztosítsa az alkatrészt leesés ellen.

Követelmény:

- ✔ A készüléket leválasztotta az áramellátásról.
- ✔ Eltávolította a készülék belső szerelvényeit.
- ✔ Eltávolította a felső zsanért.

- ✔ Eltávolította a középső zsanért.

4.6.1 Az alsó ajtózanér eltávolítása

- ▶ 1. Csavarja ki mindkét csavart (1).
- ▶ 2. Távolítsa el az alsó zsanért (2).

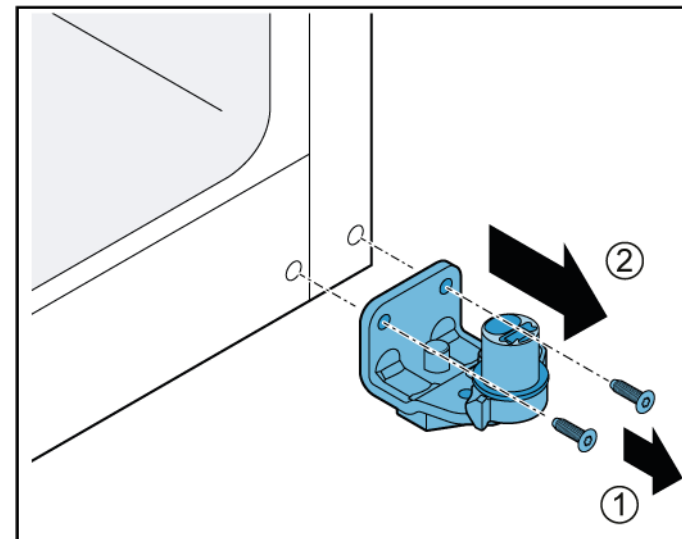

- ➡ Eltávolította az alsó ajtózanért.

4.6.2 Az alsó ajtózanér felhelyezése

- ▶ Az elhelyezést fordított sorrendben végezze.

4.7 A polc cseréje

Követelmény:

- ✔ Az ajtó nyitva van

4.7.1 A polc eltávolítása

- ▶ 1. Emelje meg a polc hátsó részét (1).
- ▶ 2. A polc kilazul (2).

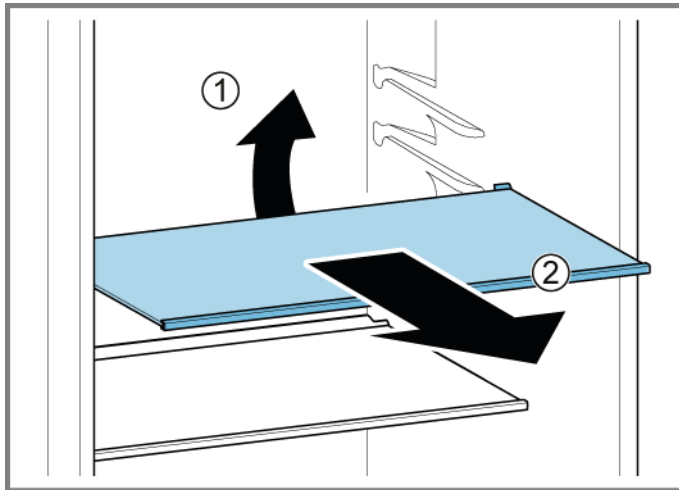

➡ Eltávolította a polcot.

4.7.2 A polc beszerelése

- ▶ Az elhelyezést fordított sorrendben végezze.

4.8 A palacktartó cseréje

Követelmény:

- ✓ Az ajtó nyitva van

4.8.1 A palacktartó eltávolítása

- ▶ Húzza ki a palacktartót.

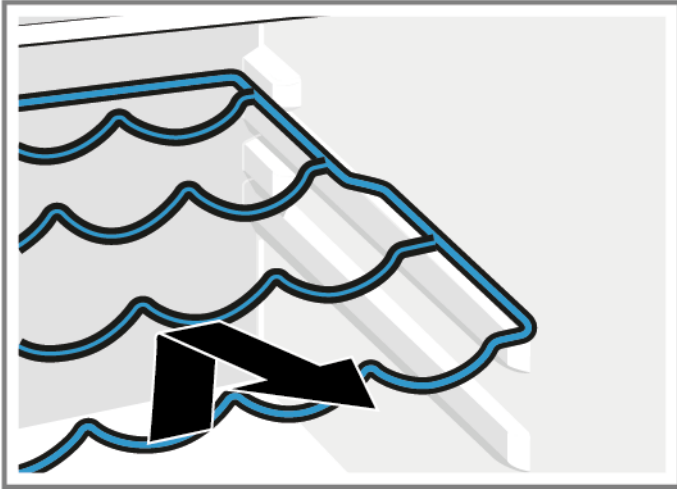

- ➡ Eltávolította a palacktartót.

4.8.2 A palacktartó telepítése

- ▶ Az elhelyezést fordított sorrendben végezze.

4.9 Az ajtópolc cseréje

Követelmény:

- ✓ Az ajtó nyitva van

4.9.1 Az ajtópolc eltávolítása

- ▶ Emelje fel az ajtópolcot.

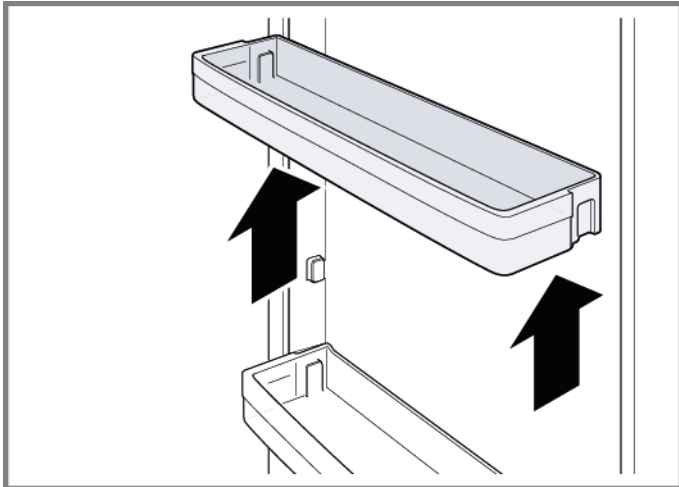

- ➡ Eltávolította az ajtópolcot.

4.9.2 Az ajtópolc felhelyezése

- ▶ Az elhelyezést fordított sorrendben végezze.

4.10 Tárolótartály cseréje

Követelmény:

- ✔ Az ajtó nyitva van

4.10.1 Tárolótartály eltávolítása

1. Húzza ki a tárolótartályt, amennyire csak tudja.
2. 1. Maga felé húzva emelje ki a tárolótartályt (1).
2. Távolítsa el a tárolótartályt (2).

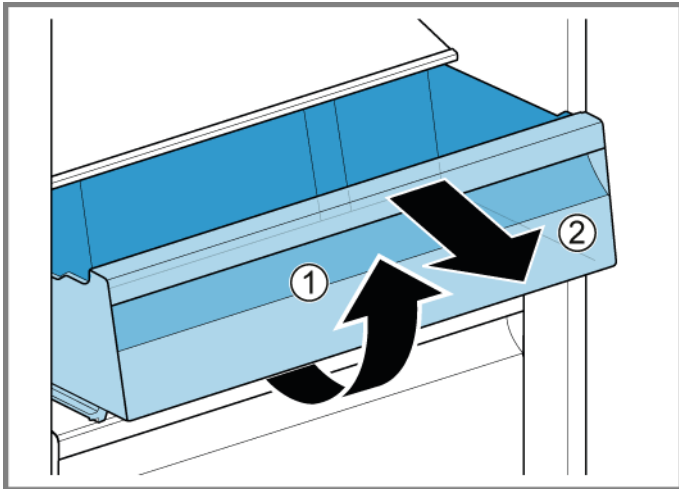

- ➔ Eltávolította a tárolótartályt.

4.10.2 A tárolótartály behelyezése

- ▶ Az elhelyezést fordított sorrendben végezze.

4.11 A gyümölcs- és zöldségtároló cseréje

Követelmény:

- ✔ Az ajtó nyitva van

4.11.1 A gyümölcs- és zöldségtároló eltávolítása

1. Húzza ki a zöldség- és gyümölcstárolót, amennyire csak tudja.
2. 1. Maga felé húzva emelje ki a zöldség- és gyümölcstárolót (1).
2. Távolítsa el a tárolótartályt (2).

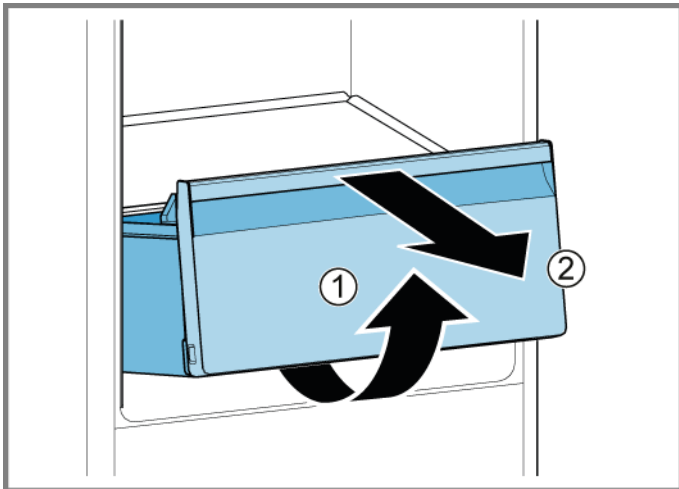

- ➔ Eltávolította a gyümölcs- és zöldségtárolót.

4.11.2 A gyümölcs- és zöldségtároló behelyezése

- ▶ Az elhelyezést fordított sorrendben végezze.

4.12 A gyümölcs- és zöldségtároló feletti polc cseréje

Követelmény:

- ✓ Az ajtó nyitva van
- ✓ [Eltávolította a gyümölcs- és zöldségtárolót.](#)→350

4.12.1 A gyümölcs- és zöldségtároló feletti polc eltávolítása

1. Tolja felfelé és kifelé a tömítőkeretet.

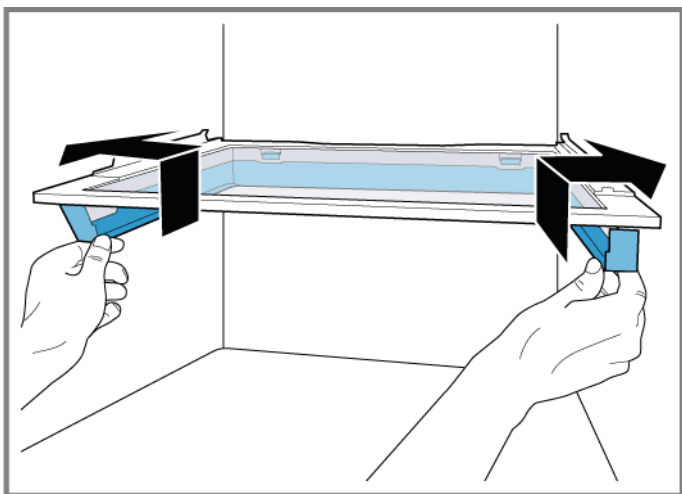

- ➡ Az oldalsó horgok kioldanak.

2. Emelje meg a tömítőkeretet, és tolja hátrafelé.

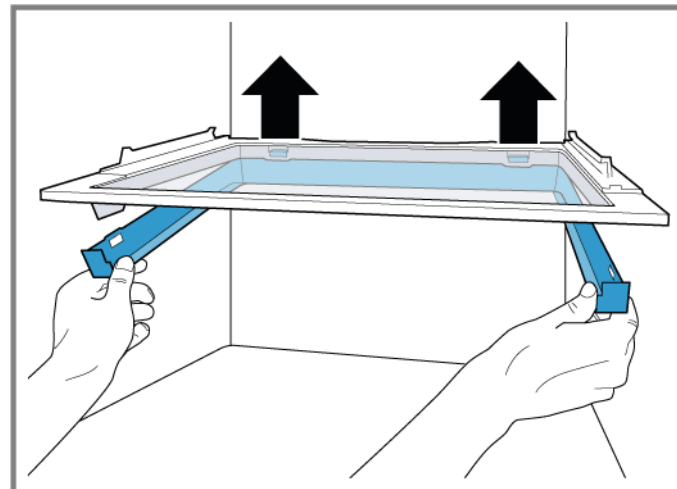

- ➡ A hátsó horgok kioldanak.

3. Távolítsa el a tömítőkeretet.
4. Emelje meg a gyümölcs- és zöldségtároló feletti polcot, és fordítsa oldalra.

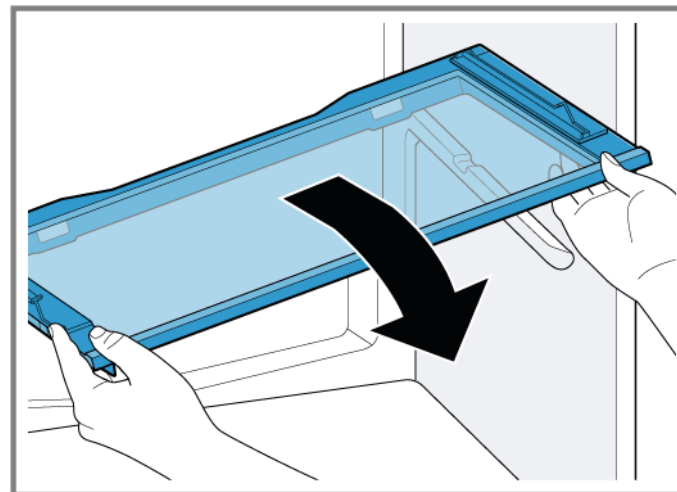

- ➡ Eltávolította a gyümölcs- és zöldségtároló feletti polcot.

4.12.2 A gyümölcs- és zöldségtároló feletti polc behelyezése

- ▶ Az elhelyezést fordított sorrendben végezze.

4.13 Fagyasztódoboz cseréje

Követelmény:

- ✓ Az ajtó nyitva van

4.13.1 Fagyasztódoboz eltávolítása

- ▶ 1. Húzza ki teljesen a fagyasztódobozt (1).
- ▶ 2. Távolítsa el a fagyasztódobozt (2).

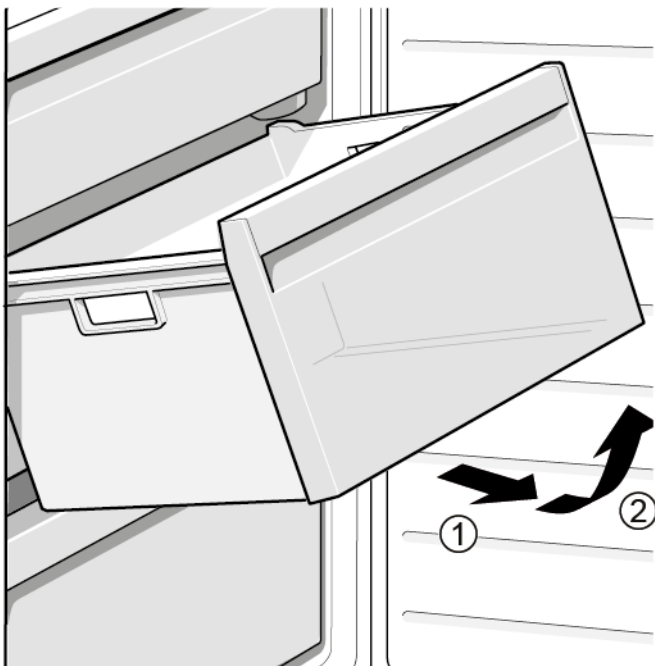

- ➡ Eltávolította a fagyasztódobozt.

4.13.2 A fagyasztódoboz behelyezése

- ▶ Az elhelyezést fordított sorrendben végezze.

4.14 A felső LED-es lámpa cseréje

Különleges eszközök

Különleges szerszám

[00342180]



A készüléke karbantartásmentes LEDvilágítással rendelkezik.
A világítást kizárólag az ügyfélszolgálat vagy szakképzett szerelő javíthatja meg!



⚠ VESZÉLY

Áramütés veszélye áram alatt lévő alkatrészek miatt!

Életveszély a nem megfelelő javítás okozta áramütés miatt

- ▶ Az elektromos alkatrészek javítását kizárólag képzett elektroműszerész végezheti.
- ▶ A javítás után végeztesen a VDE 0701-nek vagy az országspecifikus szabályozásoknak megfelelő vizsgálatot.



⚠ VESZÉLY

Áramütés veszélye áram alatt lévő alkatrészek miatt!

Halálos áramütés

- ▶ A javítás megkezdése előtt legalább 60 másodperccel válassza le a készülékeket az elektromos hálózatról.



⚠ VIGYÁZAT

Éles szélek!

Vágási sérülések

- ▶ Viseljen védőkesztyűt.

Követelmény:

- ✓ A készüléket leválasztotta az áramellátásról.
- ✓ Az ajtó nyitva van

4.14.1 A felső LED-es lámpa eltávolítása

1. Csúsztassa be a szerelőeszközt a felső LED-es lámpa és a hűtőszekrény belső felülete közé a lámpát tartó horgok kioldásához (1).
2. Távolítsa el a felső LED-es lámpát (2).

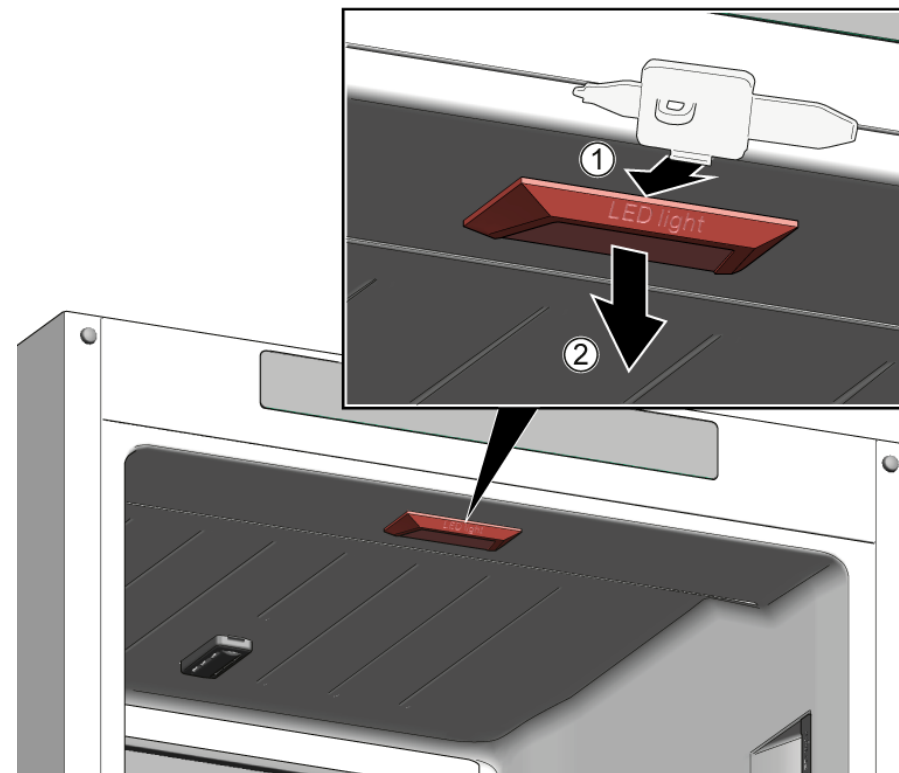

2. Válassza le a felső LED-es lámpa elektromos csatlakozását.
- ➡ Eltávolította a felső LED-es lámpát.

4.14.2 A felső LED-es lámpa beszerelése

- ▶ Az elhelyezést fordított sorrendben végezze.

4.15 Az oldalsó LED-es lámpa cseréje

Különleges eszközök

 Különleges szerszám

[00342180]

 A készüléke karbantartásmentes LEDvilágítással rendelkezik. A világítást kizárólag az ügyfélszolgálat vagy szakképzett szerelő javíthatja meg!

 **VESZÉLY**
Áramütés veszélye áram alatt lévő alkatrészek miatt!
 Életveszély a nem megfelelő javítás okozta áramütés miatt

- ▶ Az elektromos alkatrészek javítását kizárólag képzett elektroműszerész végezheti.
- ▶ A javítás után végeztesen a VDE 0701-nek vagy az országspecifikus szabályozásoknak megfelelő vizsgálatot.

 **VESZÉLY**
Áramütés veszélye áram alatt lévő alkatrészek miatt!
 Halálos áramütés

- ▶ A javítás megkezdése előtt legalább 60 másodperccel válassza le a készülékeket az elektromos hálózatról.



 **VIGYÁZAT**
Éles szélek!
 Vágási sérülések

- ▶ Viseljen védőkesztyűt.

 **FIGYELEM!**
Elektrosztatikailag érzékeny alkatrészek (ESD-k) károsodásának veszélye!!
 Alkatrészek károsodása

- ▶ Az ESD-k megérintése előtt használjon elektrosztatikus védelmi rendszert (földeléssel ellátott karpántot).
- ▶ Ne érintse meg a modulok csatlakozásait és vezetőit.
- ▶ Az ESD-eket kizárólag vezetőképes anyagokban vagy az eredeti csomagolásban szállítsa.
- ▶ Tartsa távol az ESD-eket az elektrosztatikusan feltöltődő anyagoktól (pl. műanyag).

Követelmény:

-  A készüléket leválasztotta az áramellátásról.
-  Az ajtó nyitva van
-  Eltávolította a hűtőszekrény belső szerelvényeit.

4.15.1 Az oldalsó LED-es lámpa eltávolítása

1. Csúsztassa be a szerelőeszközt a lámpabúra és a lámpatest közé a hurok kioldásához (1).
2. Vegye ki a lámpabúrát (2).
3. Ugyanezzel az eljárással oldja ki a lámpabúra rögzítőhorgait.

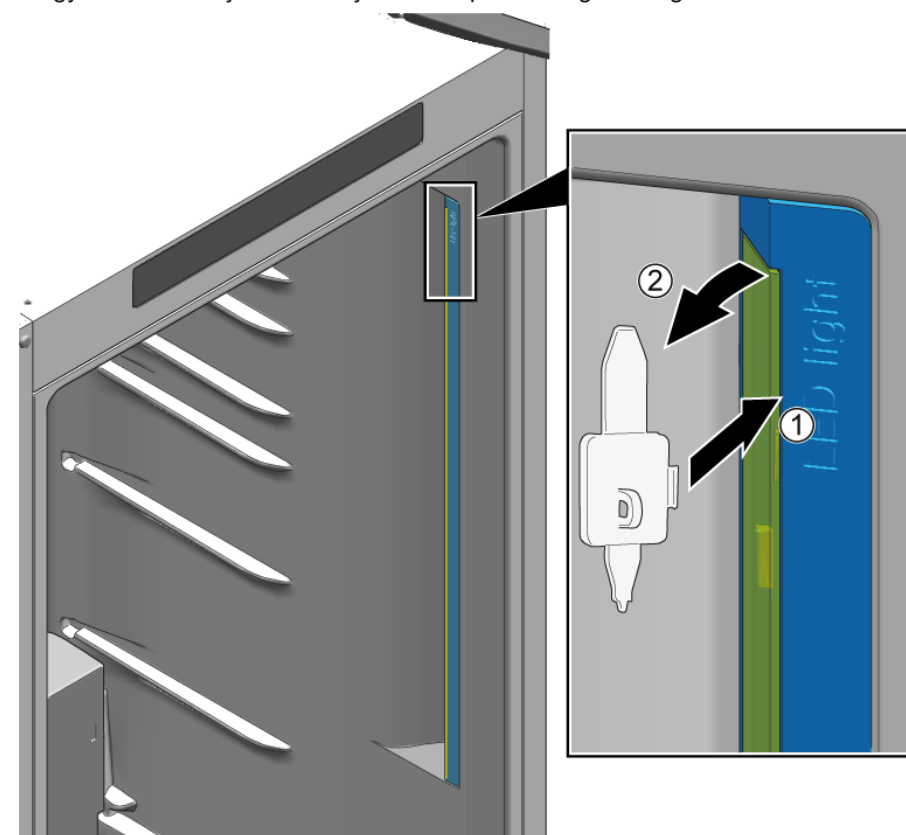

 Eltávolította a lámpabúrát.

1. A kioldáshoz nyomja le a rögzítőhorgot (1).
2. Emelje meg a LED modult kb. 1 cm-t, így kiemelheti a foglalatból (2).
3. Távolítsa el a LED-es modult (3).

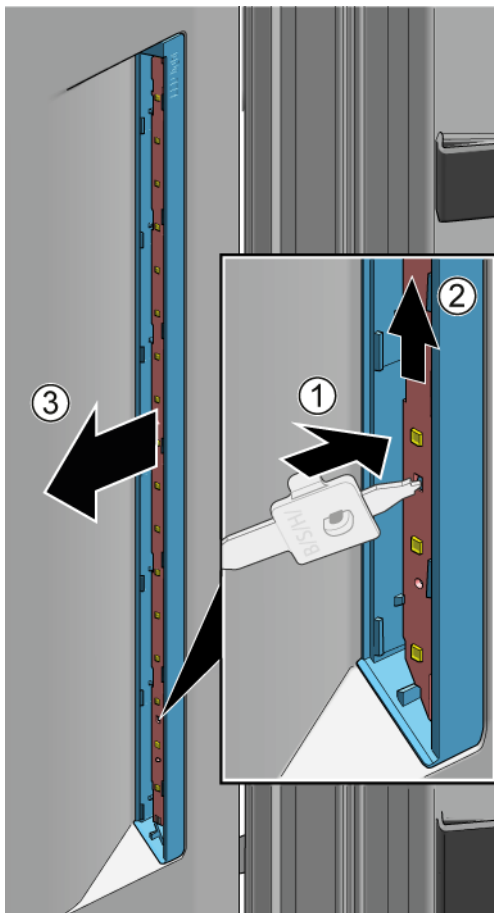

 Eltávolította az oldalsó LED-es lámpát.

4.15.2 Az oldalsó LED-es lámpa beszerelése



A lámpaburkolat horgai könnyen eltörhetnek az eltávolítás során, ezért az oldalsó LED-es lámpa pótkészlete a LED-es modult és a lámpaburkolatot is tartalmazza.

1. Csúsztassa be a szerelőeszközt a lámpabúra és a lámpatest közé a hurok kioldásához (1).
2. Vegye ki a lámpabúrát (2).
3. Ugyanezzel az eljárással oldja ki a lámpabúra rögzítőhorgait.

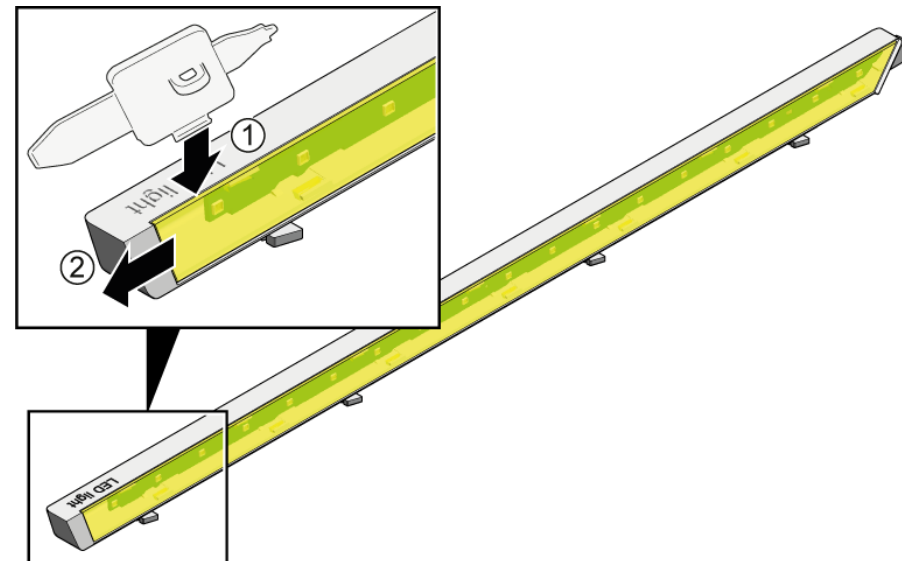

Javítás

1. A kioldáshoz nyomja le a rögzítőhorgot (1).
2. Csúsztassa ki a LED-modult felfelé a házból.
3. Biztonsági okokból ártalmatlanítsa a pótalkatrészek szállítására használt LED-modul házát (3).

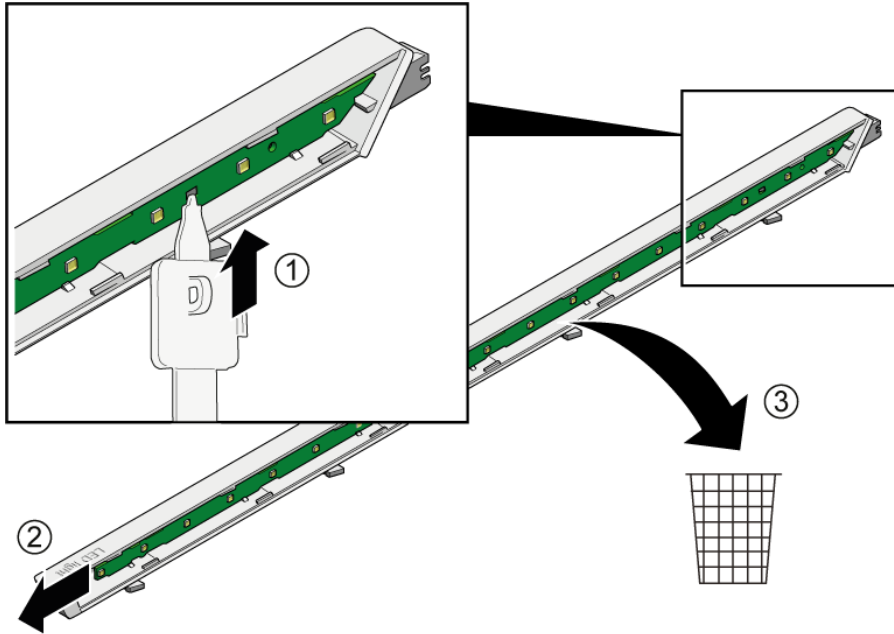

3. Az eltávolításhoz képest fordított sorrendben telepítse a LED-modult és a lámpabúrát.

4.16 A fagyasztó LED-es lámpájának cseréje

Különleges eszközök

 Különleges szerszám [00342180]

 A készüléke karbantartásmentes LEDvilágítással rendelkezik.
A világítást kizárólag az ügyfélszolgálat vagy szakképzett szerelő javíthatja meg!

 **⚠ VESZÉLY**
Áramütés veszélye áram alatt lévő alkatrészek miatt!
Életveszély a nem megfelelő javítás okozta áramütés miatt

- ▶ Az elektromos alkatrészek javítását kizárólag képzett elektroműszerész végezheti.
- ▶ A javítás után végeztesen a VDE 0701-nek vagy az országspecifikus szabályozásoknak megfelelő vizsgálatot.



 **⚠ VESZÉLY**
Áramütés veszélye áram alatt lévő alkatrészek miatt!
Halálos áramütés

- ▶ A javítás megkezdése előtt legalább 60 másodperccel válassza le a készülékeket az elektromos hálózatról.

 **⚠ VIGYÁZAT**
Éles szélek!
Vágási sérülések

- ▶ Viseljen védőkesztyűt.

Követelmény:

-  A készüléket leválasztotta az áramellátásról.
-  Az ajtó nyitva van

4.16.1 A fagyasztó LED-es lámpájának eltávolítása

- ▶ 1. Csúsztassa be a szerelőeszközt a lámpa és a lámpatest közé a lámpa oldalán, hogy a kettő között rés nyíljon (1).
- ▶ 2. Csúsztassa be a szerelőeszközt a lámpa másik oldalán a rögzítőhorgokhoz, és fordítsa el az eszközt (2).
- ▶ 3. Távolítsa el a fagyasztó LED-es lámpáját (3).

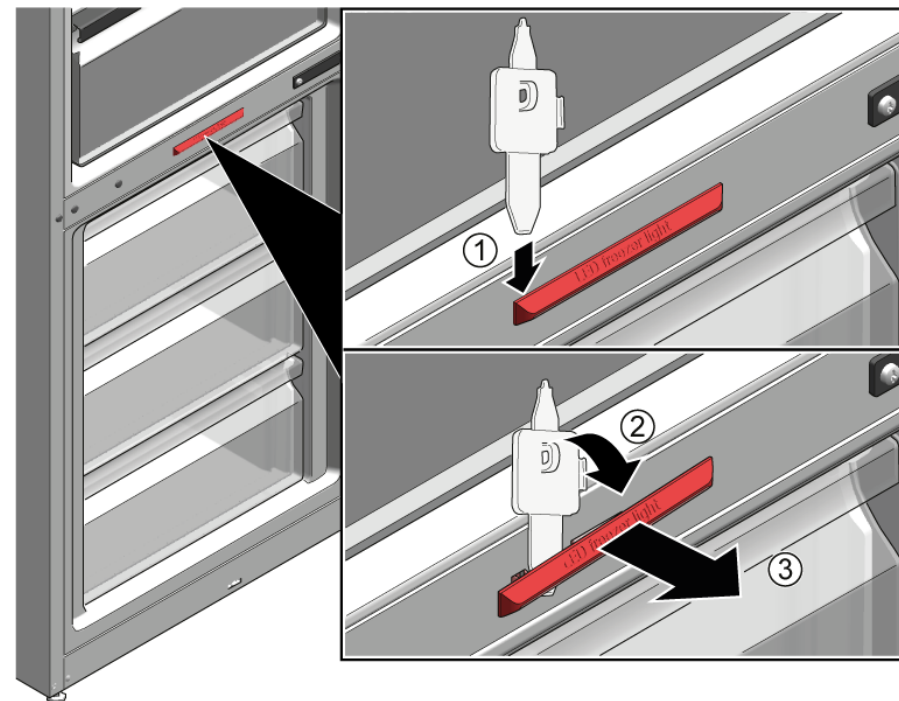





-  A fagyasztó LED-es lámpáját leválasztotta a készülékről.
-  Eltávolította a fagyasztó LED-es lámpáját.

4.16.2 A fagyasztó LED-es lámpájának beszerelése

- ▶ Az elhelyezést fordított sorrendben végezze.

Consigli di riparazione - Combinazione frigorifero / congelatore

 Utilizzo del documento	360
1.1 Avvertenze importanti	360
1.1.1 Scopo	360
1.2 Spiegazione dei simboli	360
1.2.1 Livelli di pericolo	360
1.2.2 Simboli di pericolo	360
1.2.3 Struttura degli avvertimenti	361
1.2.4 Simboli generici	361
 Sicurezza	362
2.1 Note generali sulla sicurezza	362
2.1.1 Tutti gli elettrodomestici	362
 Strumenti e ausili	363
 Riparazione	364
4.1 Sostituzione della guarnizione della porta	364
4.1.1 Smontaggio della guarnizione della porta	364
4.1.2 Montaggio della guarnizione della porta	364
4.2 Sostituzione della maniglia della porta	367
4.2.1 Smontaggio della maniglia della porta	367
4.2.2 Montaggio della maniglia della porta	367
4.3 Sostituzione della cerniera superiore della porta	368
4.3.1 Smontaggio della cerniera superiore della porta	368
4.3.2 Montaggio della cerniera superiore della porta	369
4.4 Sostituzione della cerniera superiore della porta (porta con display)	370
4.4.1 Smontaggio della cerniera superiore della porta	371
4.4.2 Montaggio della cerniera superiore della porta	372
4.5 Sostituzione della cerniera centrale della porta	373
4.5.1 Smontaggio della cerniera centrale della porta	373
4.5.2 Montaggio della cerniera centrale della porta	374
4.6 Sostituzione della cerniera inferiore della porta	375
4.6.1 Smontaggio della cerniera inferiore della porta	375
4.6.2 Montaggio della cerniera inferiore della porta	375
4.7 Sostituzione del ripiano	376
4.7.1 Smontaggio del ripiano	376
4.7.2 Montaggio del ripiano	376
4.8 Sostituzione del portabottiglie	377
4.8.1 Smontaggio del portabottiglie	377
4.8.2 Montaggio del portabottiglie	377
4.9 Sostituzione del balconcino della porta	378
4.9.1 Smontaggio del balconcino della porta	378
4.9.2 Montaggio del balconcino della porta	378
4.10 Reinserimento del cassetto	379
4.10.1 Estrazione del cassetto	379
4.10.2 Inserimento del cassetto	379
4.11 Sostituzione del cassetto frutta e verdura	380
4.11.1 Rimozione del cassetto frutta e verdura	380
4.11.2 Inserimento del cassetto frutta e verdura	380
4.12 Reinserimento del ripiano sopra il cassetto frutta e verdura	381
4.12.1 Estrazione del ripiano sopra il cassetto frutta e verdura	381
4.12.2 Inserimento del ripiano sopra il cassetto frutta e verdura	382
4.13 Sostituzione del cassetto surgelati	383
4.13.1 Rimozione del cassetto surgelati	383
4.13.2 Inserimento del cassetto surgelati	383
4.14 Sostituzione della luce superiore a LED	384
4.14.1 Smontaggio della luce superiore a LED	384
4.14.2 Montaggio della luce superiore a LED	384
4.15 Sostituzione della luce laterale a LED	385
4.15.1 Smontaggio della luce laterale a LED	385
4.15.2 Montaggio della luce laterale a LED	386
4.16 Sostituzione della luce a LED del congelatore	388
4.16.1 Smontaggio della luce a LED del congelatore	388
4.16.2 Montaggio della luce a LED del congelatore	388

i Utilizzo del documento

1.1 Avvertenze importanti

1.1.1 Scopo

Queste istruzioni di riparazione spiegano ai clienti come riparare da soli gli elettrodomestici in conformità alle regole sull'Ecodesign vigenti (al 03/2021).

Contengono informazioni sulla sostituzione di pezzi di ricambio specifici e sulle avvertenze e i rischi correlati.

In caso di domande, contattare l'assistenza tecnica. Il mancato rispetto di tali istruzioni da parte dei clienti ci esonera da qualsiasi responsabilità.

1.2 Spiegazione dei simboli

1.2.1 Livelli di pericolo

I livelli di avvertimento corrispondono a un simbolo accompagnato da una parola di allerta. La parola di allerta identifica il livello di pericolo.





Livello di avvertimento	Significato
 PERICOLO	Ignorare questo messaggio di avvertimento comporta rischio di morte o ferite gravi.
 AVVERTENZA	Ignorare questo messaggio di avvertimento può comportare rischio di morte o ferite gravi.
 ATTENZIONE	Ignorare questo messaggio di avvertimento può comportare ferite di minore gravità.
 ATTENZIONE!	Ignorare questo messaggio di avvertimento può comportare danni materiali.

Tabella 1: Livelli di pericolo

1.2.2 Simboli di pericolo

I simboli di pericolo sono illustrazioni che specificano la tipologia di rischio.

Nella presente documentazione vengono utilizzati i seguenti simboli di pericolo:

Simbolo di pericolo	Significato
	Messaggio di avvertimento generico
	Pericolo di scossa elettrica
	Pericolo di esplosione
	Rischio di ferite da taglio

i Utilizzo del documento







Simbolo di pericolo	Significato
	Pericolo di schiacciamento
	Pericolo derivante da superfici calde
	Pericolo derivante da forti campi magnetici
	Pericolo derivante da radiazioni non ionizzanti

Tabella 2: Simboli di pericolo

1.2.3 Struttura degli avvertimenti

Gli avvertimenti presenti in questo manuale hanno una forma e una struttura standardizzati.

	<p> PERICOLO</p> <p>Tipo e origine del pericolo! Possibili conseguenze in caso di pericolo/avvertimento ignorato.</p> <ul style="list-style-type: none"> ▸ Misure e divieti volti a prevenire il pericolo.
--	--

L'esempio seguente mostra un avvertimento con rischio di folgorazione dovuto a componenti sotto tensione. È riportata la misura di precauzione per evitare il pericolo.

	<p> PERICOLO</p> <p>Rischio di scossa elettrica dovuto a componenti sotto tensione! Morte per folgorazione</p> <ul style="list-style-type: none"> ▸ Scollegare l'apparecchio dall'alimentazione per almeno 60 secondi prima di iniziare la riparazione.
--	---

1.2.4 Simboli generici

Nel presente manuale vengono utilizzati i seguenti simboli generici:







Simbolo generico	Significato
	Identificazione di un suggerimento speciale (testo e/o grafica)
	Identificazione di un suggerimento semplice (solo testo)
	Identificazione di un link per un video tutorial
	Identificazione degli strumenti necessari
	Identificazione delle condizioni preve necessarie
	Identificazione di una condizione (se ..., allora ...)
	Identificazione di un risultato
[Avvio]	Identificazione di un tasto o di un pulsante
[00123456]	Identificazione di un codice articolo
Stato	Identificazione di un testo/finestra visualizzati (sul display dell'apparecchio)

Tabella 3: Simboli generici

2.1 Note generali sulla sicurezza

2.1.1 Tutti gli elettrodomestici

Rischio di scosse elettriche dovute a componenti sotto tensione!

- La riparazione non conforme dei componenti elettrici può causare scosse elettriche!
- Scollegare l'apparecchio dall'alimentazione per almeno 60 secondi prima di iniziare il lavoro.
- Ultimata la riparazione, occorre eseguire un test di sicurezza conforme alla norma VDE 0701 o alle norme specifiche del Paese.

Rischio di lesioni causate da bordi taglienti!

- Indossare guanti di protezione.

Rischio di schiacciamento dovuto a componenti pesanti e in movimento durante la riparazione, la manutenzione, la ricerca dei guasti e l'assistenza

- Indossare calzature antinfortunistiche.
- Fissare i componenti pesanti per impedire che cadano.
- Non inserire parti del corpo nei componenti in movimento.

Rischio per il funzionamento o la sicurezza dell'apparecchio!

- Utilizzare solo ricambi originali.

Rischio di danneggiamento di componenti sensibili a carica elettrostatica (ESD)!

- Non toccare i moduli, inclusi i collegamenti e le piste conduttive.

Strumenti e ausili

Designazione	Dettagli	Immagini
Punta Torx TX20 [00340865]	6,3 mm (1/4")	
Utensile speciale [00342180]		

4.1 Sostituzione della guarnizione della porta

Prerequisiti:

- ✔ La porta è aperta.

4.1.1 Smontaggio della guarnizione della porta

1. Staccare la guarnizione della porta dalla scanalatura negli angoli destro e sinistro.

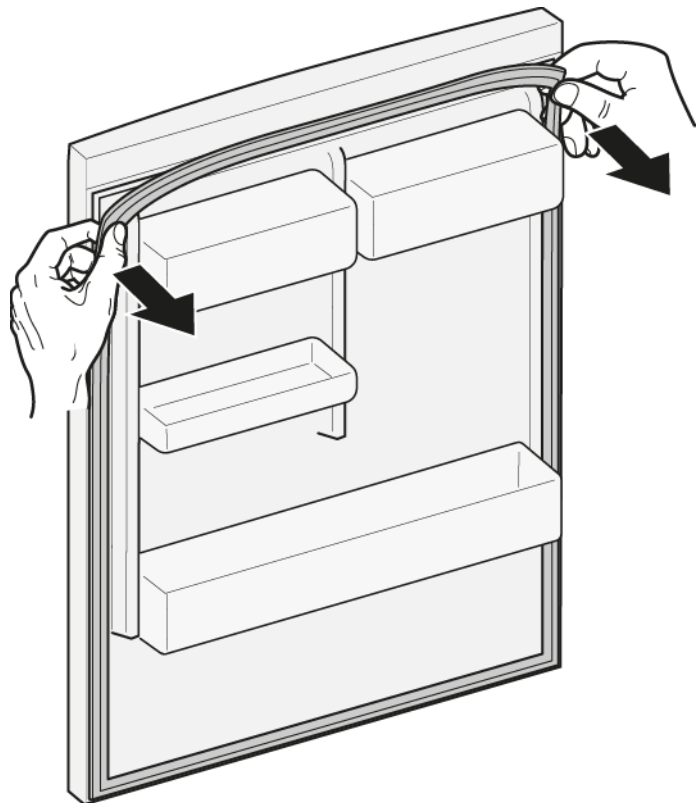

2. Estrarre la guarnizione della porta dalla scanalatura.

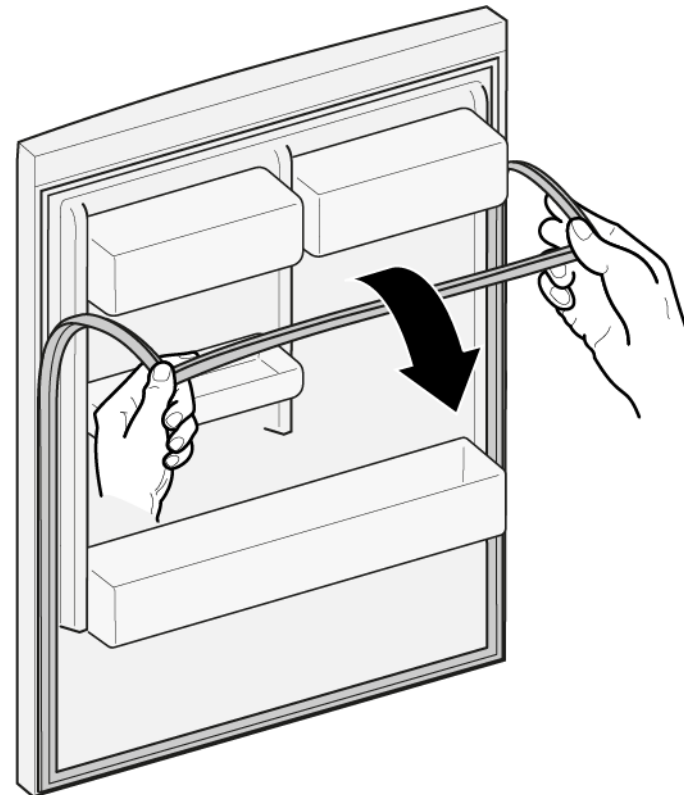

- ➡ La guarnizione della porta è rimossa.

4.1.2 Montaggio della guarnizione della porta



Lo spessore della nuova guarnizione della porta può essere leggermente diverso dallo spessore di quella vecchia. Ciò non incide sulla chiusura e sul funzionamento a lungo termine.

Se l'apparecchio è dotato di cerniere regolabili o accessori, è possibile ottimizzare il comportamento di chiusura.

I piccoli fori laterali nella guarnizione della porta sono funzionali (necessari per la ventilazione). Non si tratta di difetti di produzione.

Riparazione

1. Controllare che la scanalatura della guarnizione non sia danneggiata.

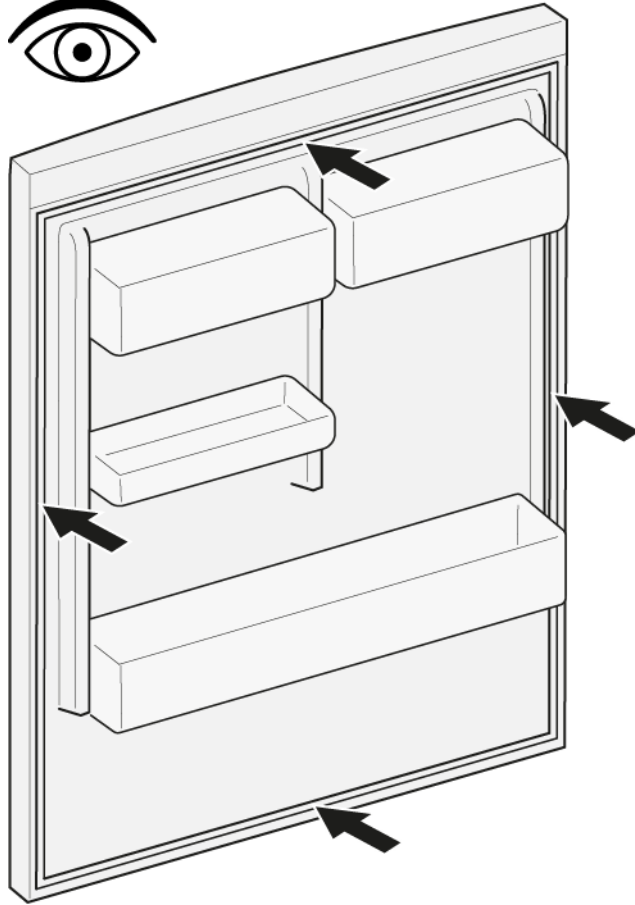

4. Spingere gli angoli della guarnizione nella scanalatura in alto e in basso.

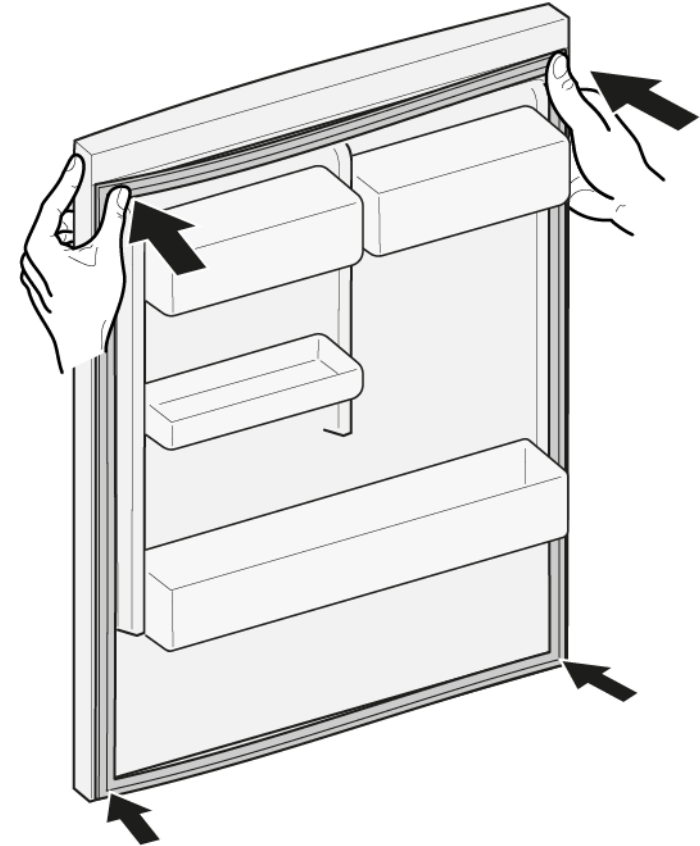

2.  Se la scanalatura della guarnizione è danneggiata.
- Contattare l'assistenza tecnica.

3.  Una leggera deformazione della guarnizione della porta è normale e non incide sul funzionamento. Si consiglia di raddrizzare la guarnizione della porta prima di inserirla nell'apparecchio.

Riscaldare la guarnizione della porta con un asciugacapelli o acqua calda e ridarle la forma manualmente.

Riparazione

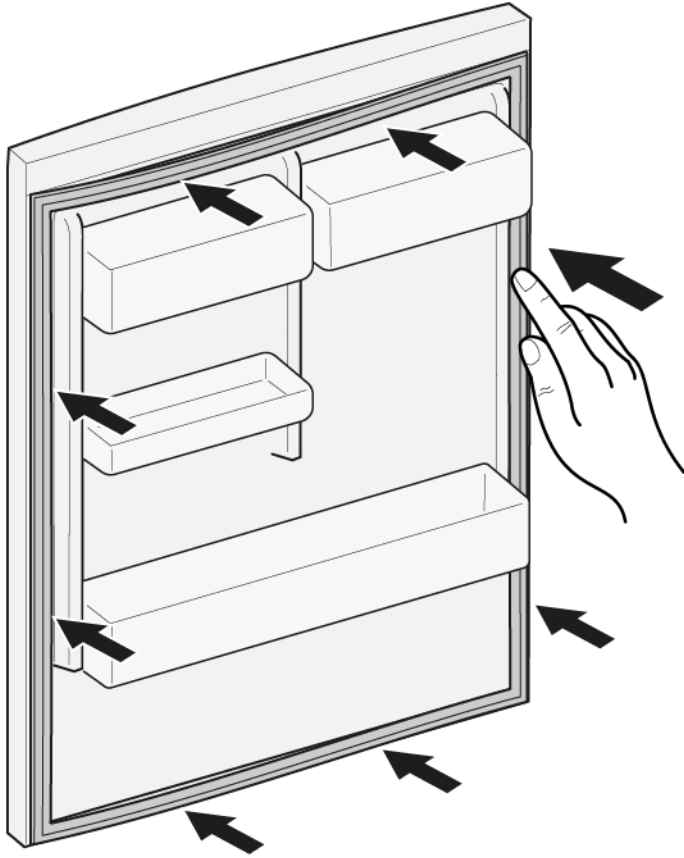

5. Premere la guarnizione nella scanalatura un pezzo per volta.





-  La guarnizione della porta è montata.

4.2 Sostituzione della maniglia della porta

Attrezzi speciali:

-  Punta Torx TX20 6,3 mm (1/4") [00340865]
-  Cacciavite a taglio Lama 10 mm x 1,6 mm x 200 mm

Prerequisiti:

-  L'apparecchio è scollegato dalla rete elettrica.
-  La porta è aperta.

4.2.1 Smontaggio della maniglia della porta

- ▶ 1. Togliere i due tappi delle viti (1).
- ▶ 2. Svitare le due viti (2).
- ▶ 3. Smontare la maniglia della porta (3).

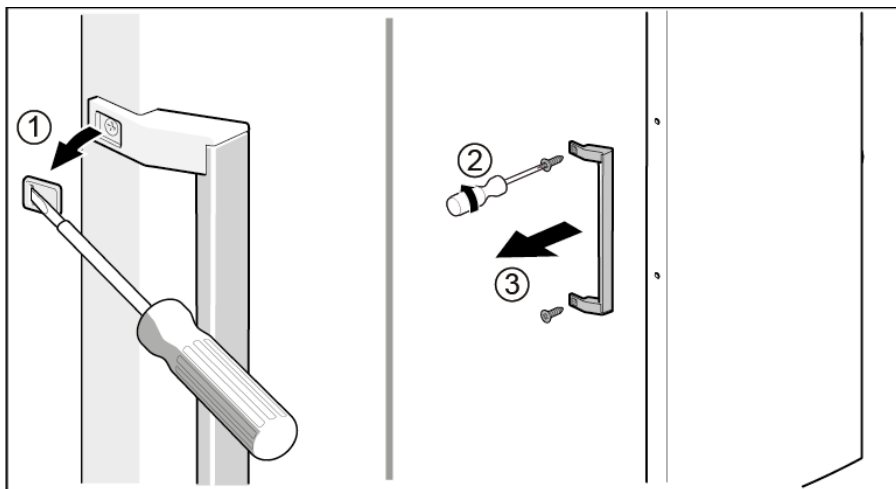

 La maniglia della porta è rimossa.



La maniglia della seconda porta può essere rimossa nello stesso modo.

4.2.2 Montaggio della maniglia della porta

- ▶ Per il montaggio, seguire la procedura sopra descritta in senso opposto.

4.3 Sostituzione della cerniera superiore della porta

Attrezzi speciali:

🔧 Punta Torx TX20 6,3 mm (1/4") [00340865]

	⚠️ AVVERTENZA
	<p>Apparecchi pesanti, ingombranti! Rischio di infortuni muscolari e alla schiena</p> <ul style="list-style-type: none"> ▶ L'operazione di smontaggio della porta dell'apparecchio deve essere eseguita soltanto da tecnici addestrati. ▶ Spostare l'apparecchio in due persone. ▶ Usare solo utensili e attrezzature idonei.

	⚠️ ATTENZIONE
	<p>Bordi taglienti! Ferite da taglio</p> <ul style="list-style-type: none"> ▶ Indossare guanti di protezione.

	⚠️ AVVERTENZA
	<p>Gli apparecchi inclinati possono scivolare! Fratture / lesioni da schiacciamento</p> <ul style="list-style-type: none"> ▶ Fissare gli apparecchi in modo che non scivolino.

	⚠️ ATTENZIONE
	<p>Rischio di caduta di componenti a causa di viti allentate! Lesioni provocate dalla caduta di componenti.</p> <ul style="list-style-type: none"> ▶ Fissare i componenti in modo che non cadano.

	ATTENZIONE!
	<p>Rischio di caduta di componenti a causa di viti allentate! Danni a altre parti dell'apparecchio o all'abitazione del cliente, ad es. parte inferiore.</p> <ul style="list-style-type: none"> ▶ Fissare i componenti in modo che non cadano.

Prerequisiti:

- ✔ L'apparecchio è scollegato dalla rete elettrica.
- ✔ Gli accessori interni dell'apparecchio sono stati rimossi.

4.3.1 Smontaggio della cerniera superiore della porta

1. Far scorrere la parte di supporto sotto la sezione della base.

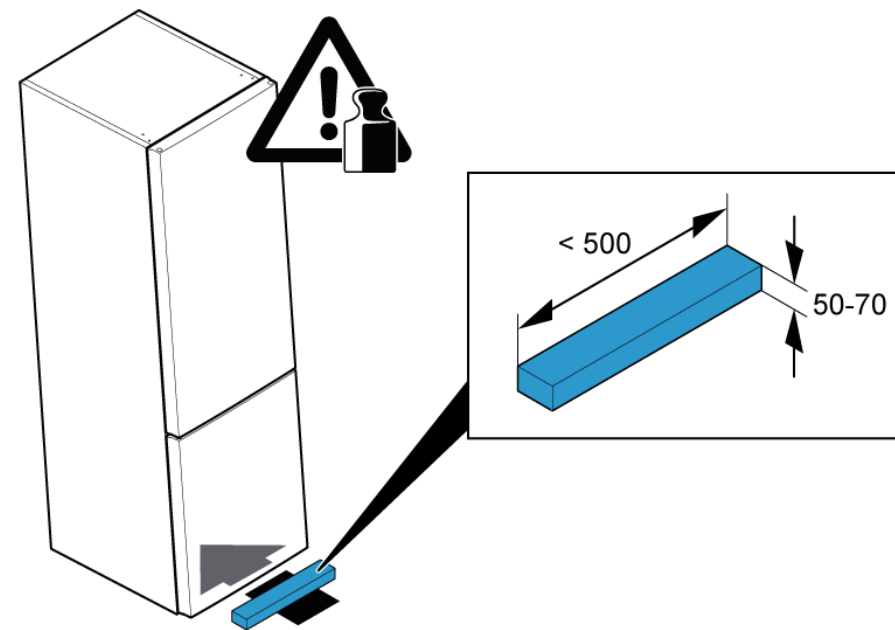

2. 1. Togliere la copertura superiore della cerniera (1).
2. Svitare le due viti (2).
3. Togliere la cerniera superiore (3).

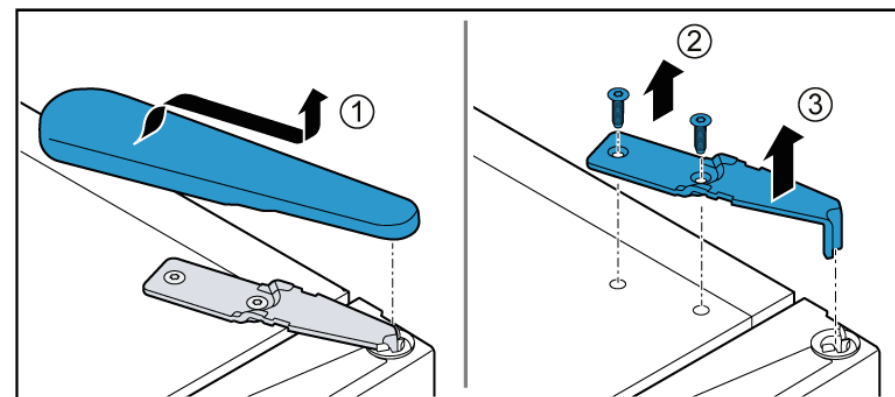

3. Togliere la porta superiore.

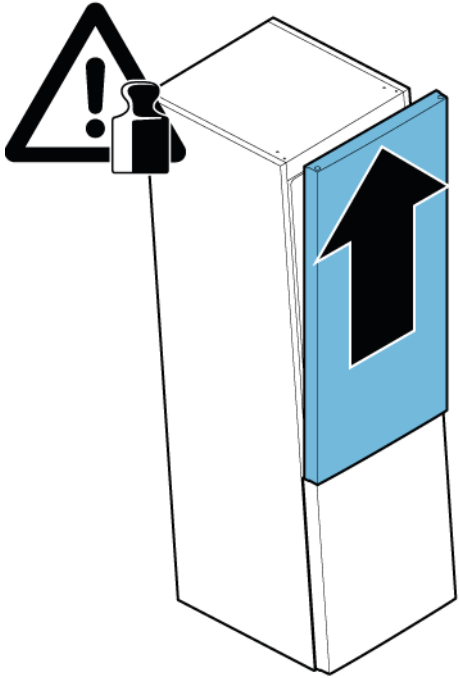

➡ La cerniera superiore è rimossa.

4.3.2 Montaggio della cerniera superiore della porta

- ▶ Per il montaggio, seguire la procedura sopra descritta in senso opposto.

4.4 Sostituzione della cerniera superiore della porta (porta con display)

Attrezzi speciali:

 Punta Torx TX20 6,3 mm (1/4") [00340865]

	⚠ AVVERTENZA
	<p>Apparecchi pesanti, ingombranti! Rischio di infortuni muscolari e alla schiena</p> <ul style="list-style-type: none"> ▶ L'operazione di smontaggio della porta dell'apparecchio deve essere eseguita soltanto da tecnici addestrati. ▶ Spostare l'apparecchio in due persone. ▶ Usare solo utensili e attrezzature idonei.

	⚠ ATTENZIONE
	<p>Bordi taglienti! Ferite da taglio</p> <ul style="list-style-type: none"> ▶ Indossare guanti di protezione.

	⚠ AVVERTENZA
	<p>Gli apparecchi inclinati possono scivolare! Fratture / lesioni da schiacciamento</p> <ul style="list-style-type: none"> ▶ Fissare gli apparecchi in modo che non scivolino.



	⚠ ATTENZIONE
	<p>Rischio di caduta di componenti a causa di viti allentate! Lesioni provocate dalla caduta di componenti.</p> <ul style="list-style-type: none"> ▶ Fissare i componenti in modo che non cadano.

	ATTENZIONE!
	<p>Rischio di caduta di componenti a causa di viti allentate! Danni a altre parti dell'apparecchio o all'abitazione del cliente, ad es. parte inferiore.</p> <ul style="list-style-type: none"> ▶ Fissare i componenti in modo che non cadano.

	⚠ PERICOLO
	<p>Rischio di scosse elettriche dovute a componenti sotto tensione! Pericolo di morte dovuto a scosse elettriche in caso di riparazione non conforme</p> <ul style="list-style-type: none"> ▶ Le parti elettriche devono essere riparate da elettricisti qualificati. ▶ Ultimata la riparazione, occorre eseguire un test di sicurezza conforme alla norma VDE 0701 o alle norme specifiche del Paese.

	⚠ PERICOLO
	<p>Rischio di scossa elettrica dovuto a componenti sotto tensione! Morte per folgorazione</p> <ul style="list-style-type: none"> ▶ Scollegare l'apparecchio dall'alimentazione per almeno 60 secondi prima di iniziare la riparazione.

Prerequisiti:

-  L'apparecchio è scollegato dalla rete elettrica.
-  Gli accessori interni dell'apparecchio sono stati rimossi.

4.4.1 Smontaggio della cerniera superiore della porta

1. Far scorrere la parte di supporto sotto la sezione della base.

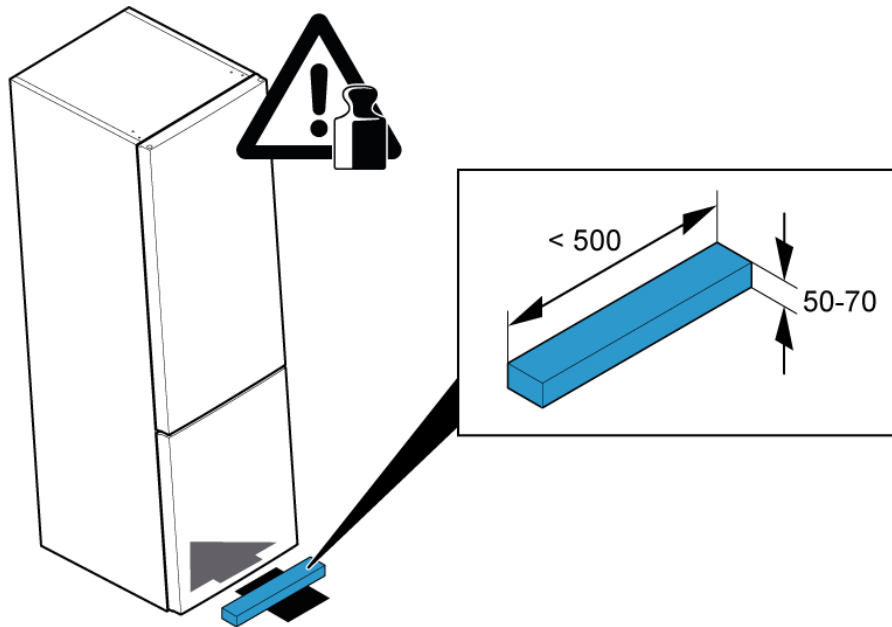

2. 1. Togliere la copertura superiore della cerniera (1).
2. Staccare il collegamento elettrico (2).
3. Svitare la vite del collegamento di messa a terra (3).

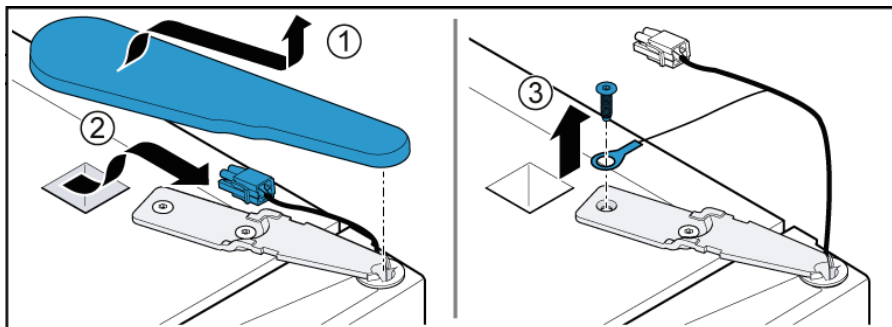

3. 1. Svitare la vite (1).
2. Togliere la cerniera superiore (2).

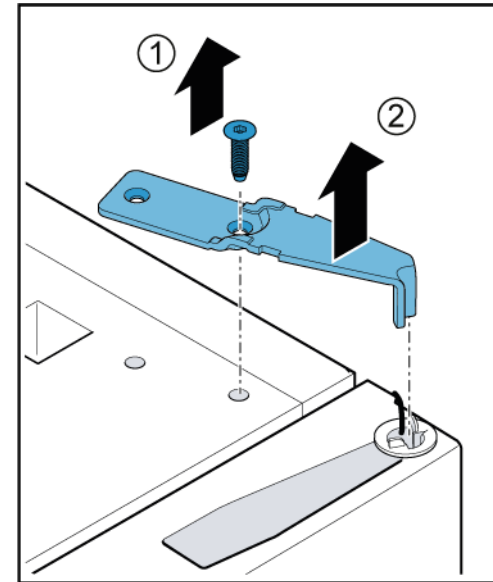

4. Togliere la porta superiore.

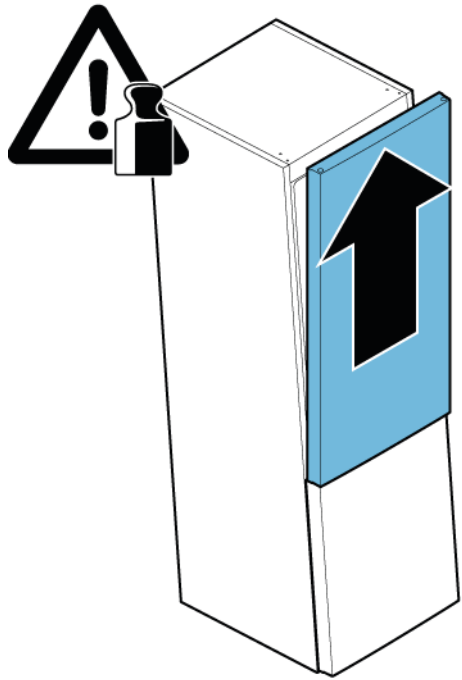

➡ La cerniera superiore è rimossa.

4.4.2 Montaggio della cerniera superiore della porta

- ▶ Per il montaggio, seguire la procedura sopra descritta in senso opposto.

4.5 Sostituzione della cerniera centrale della porta

Attrezzi speciali:

 Punta Torx TX20 6,3 mm (1/4") [00340865]

	AVVERTENZA
	Apparecchi pesanti, ingombranti! Rischio di infortuni muscolari e alla schiena <ul style="list-style-type: none">▶ L'operazione di smontaggio della porta dell'apparecchio deve essere eseguita soltanto da tecnici addestrati.▶ Spostare l'apparecchio in due persone.▶ Usare solo utensili e attrezzature idonei.



	ATTENZIONE
	Bordi taglienti! Ferite da taglio <ul style="list-style-type: none">▶ Indossare guanti di protezione.

	AVVERTENZA
	Gli apparecchi inclinati possono scivolare! Fratture / lesioni da schiacciamento <ul style="list-style-type: none">▶ Fissare gli apparecchi in modo che non scivolino.

	ATTENZIONE
	Rischio di caduta di componenti a causa di viti allentate! Lesioni provocate dalla caduta di componenti. <ul style="list-style-type: none">▶ Fissare i componenti in modo che non cadano.

	ATTENZIONE!
	Rischio di caduta di componenti a causa di viti allentate! Danni a altre parti dell'apparecchio o all'abitazione del cliente, ad es. parte inferiore. <ul style="list-style-type: none">▶ Fissare i componenti in modo che non cadano.

Prerequisiti:

-  L'apparecchio è scollegato dalla rete elettrica.
-  Gli accessori interni dell'apparecchio sono stati rimossi.
-  La cerniera superiore della porta è rimossa.

-  La porta superiore è rimossa.

4.5.1 Smontaggio della cerniera centrale della porta

1. Svitare le due viti (1).
2. Rimuovere la cerniera centrale (2).

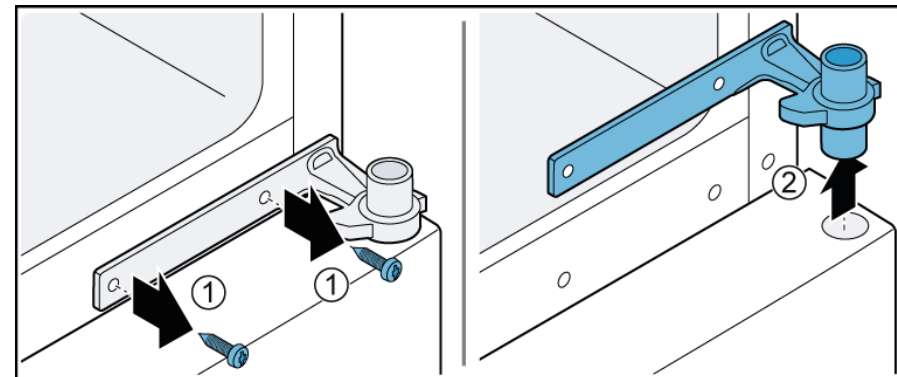

2. Togliere la porta inferiore.

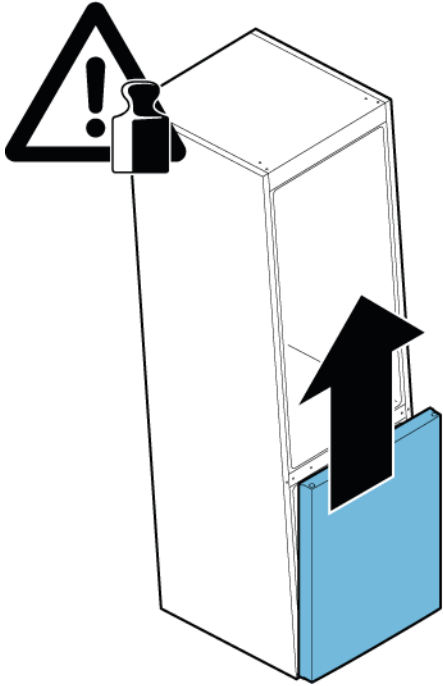

➡ La cerniera centrale è rimossa.

4.5.2 Montaggio della cerniera centrale della porta

- ▶ Per il montaggio, seguire la procedura sopra descritta in senso opposto.

4.6 Sostituzione della cerniera inferiore della porta

Attrezzi speciali:

 Punta Torx TX20 6,3 mm (1/4") [00340865]

	AVVERTENZA
	Apparecchi pesanti, ingombranti! Rischio di infortuni muscolari e alla schiena <ul style="list-style-type: none">▶ L'operazione di smontaggio della porta dell'apparecchio deve essere eseguita soltanto da tecnici addestrati.▶ Spostare l'apparecchio in due persone.▶ Usare solo utensili e attrezzature idonei.

	ATTENZIONE
	Bordi taglienti! Ferite da taglio <ul style="list-style-type: none">▶ Indossare guanti di protezione.

	AVVERTENZA
	Gli apparecchi inclinati possono scivolare! Fratture / lesioni da schiacciamento <ul style="list-style-type: none">▶ Fissare gli apparecchi in modo che non scivolino.

	ATTENZIONE
	Rischio di caduta di componenti a causa di viti allentate! Lesioni provocate dalla caduta di componenti. <ul style="list-style-type: none">▶ Fissare i componenti in modo che non cadano.

	ATTENZIONE!
	Rischio di caduta di componenti a causa di viti allentate! Danni a altre parti dell'apparecchio o all'abitazione del cliente, ad es. parte inferiore. <ul style="list-style-type: none">▶ Fissare i componenti in modo che non cadano.

Prerequisiti:

- ✔ L'apparecchio è scollegato dalla rete elettrica.
- ✔ Gli accessori interni dell'apparecchio sono stati rimossi.
- ✔ La cerniera superiore è rimossa.

- ✔ La cerniera centrale è rimossa.

4.6.1 Smontaggio della cerniera inferiore della porta

- ▶ 1. Svitare le due viti (1).
- ▶ 2. Togliere la cerniera inferiore (2).

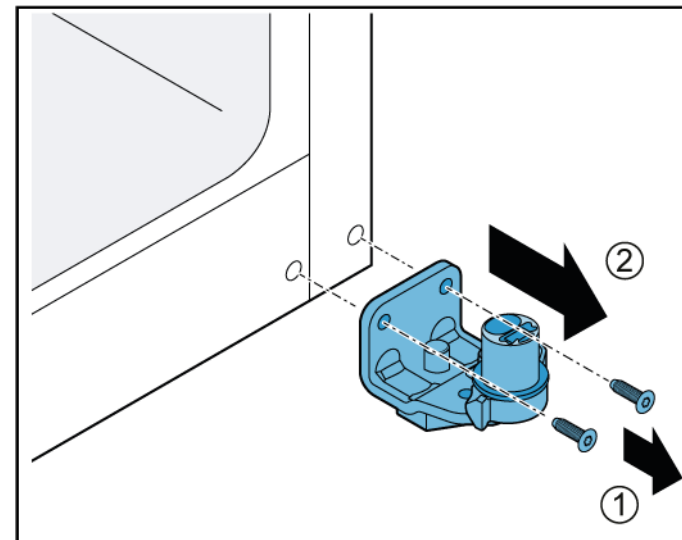

- ➡ La cerniera inferiore della porta è rimossa.

4.6.2 Montaggio della cerniera inferiore della porta

- ▶ Per il montaggio, seguire la procedura sopra descritta in senso opposto.

4.7 Sostituzione del ripiano

Prerequisiti:

- ✔ La porta è aperta.

4.7.1 Smontaggio del ripiano

- ▶ 1. Sollevare il ripiano dalla parte posteriore (1).
- ▶ 2. Rilasciare il ripiano (2).

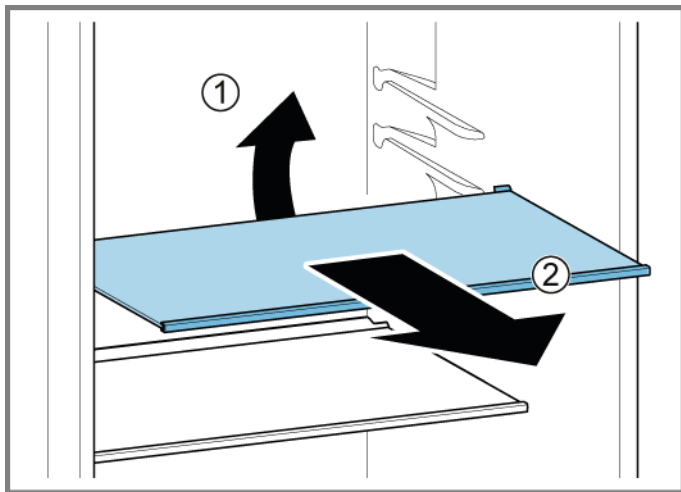

➡ Il ripiano è rimosso.

4.7.2 Montaggio del ripiano

- ▶ Per il montaggio, seguire la procedura sopra descritta in senso opposto.

4.8 Sostituzione del portabottiglie

Prerequisiti:

- ✔ La porta è aperta.

4.8.1 Smontaggio del portabottiglie

- ▶ Estrarre il portabottiglie.

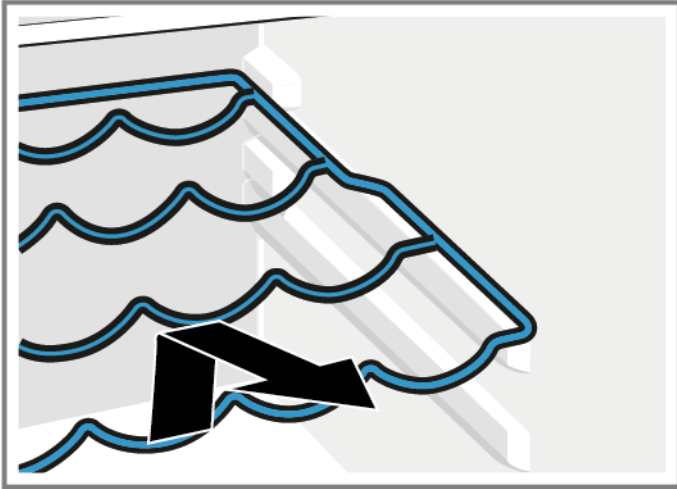

- ➡ Il portabottiglie è rimosso.

4.8.2 Montaggio del portabottiglie

- ▶ Per il montaggio, seguire la procedura sopra descritta in senso opposto.

4.9 Sostituzione del balconcino della porta

Prerequisiti:

- ✔ La porta è aperta.

4.9.1 Smontaggio del balconcino della porta

- ▶ Tirare il balconcino della porta verso l'alto.



➡ Il balconcino della porta è rimosso.

4.9.2 Montaggio del balconcino della porta

- ▶ Per il montaggio, seguire la procedura sopra descritta in senso opposto.

4.10 Reinsediamento del cassetto

Prerequisiti:

- ✔ La porta è aperta.

4.10.1 Estrazione del cassetto

1. Estrarre il cassetto il più possibile.
2. 1. Sollevare il cassetto dalla parte anteriore (1).
2. Rimuovere il cassetto (2).

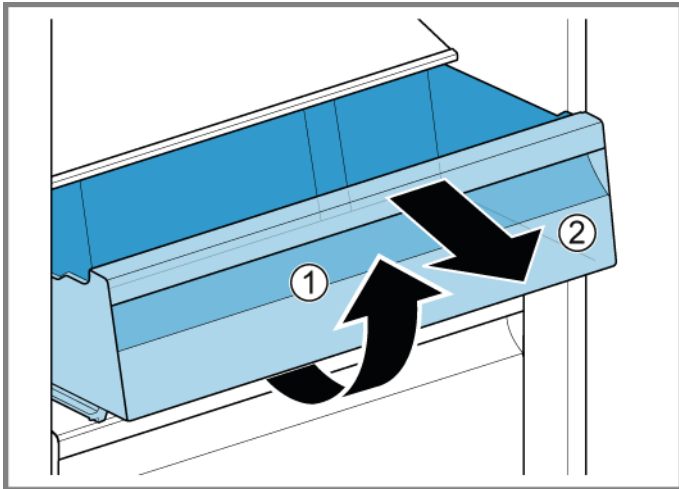

- ➡ Il cassetto è rimosso.

4.10.2 Inserimento del cassetto

- ▶ Per il montaggio, seguire la procedura sopra descritta in senso opposto.

4.11 Sostituzione del cassetto frutta e verdura

Prerequisiti:

- ✔ La porta è aperta.

4.11.1 Rimozione del cassetto frutta e verdura

1. Estrarre il cassetto frutta e verdura il più possibile.
2. 1. Sollevare il cassetto frutta e verdura dalla parte anteriore (1).
2. Rimuovere il cassetto (2).

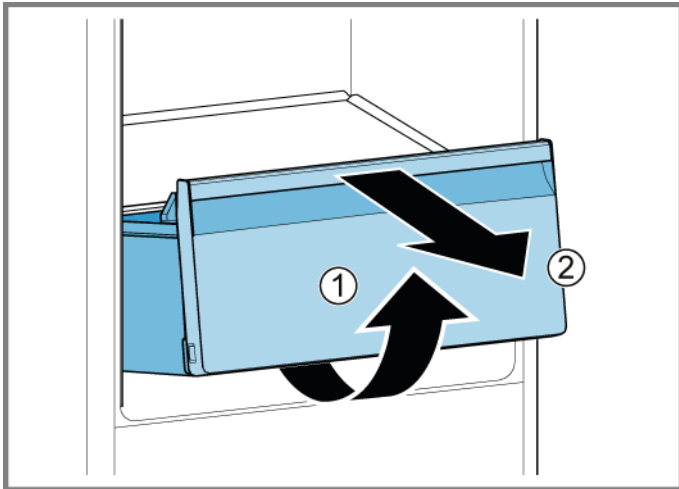

- ➡ Il cassetto frutta e verdura è rimosso.

4.11.2 Inserimento del cassetto frutta e verdura

- ▶ Per il montaggio, seguire la procedura sopra descritta in senso opposto.

4.12 Reinserimento del ripiano sopra il cassetto frutta e verdura

Prerequisiti:

- ✔ La porta è aperta.
- ✔ [Il cassetto frutta e verdura è rimosso. → 380](#)

4.12.1 Estrazione del ripiano sopra il cassetto frutta e verdura

1. Spingere il telaio verso l'alto e verso l'esterno.

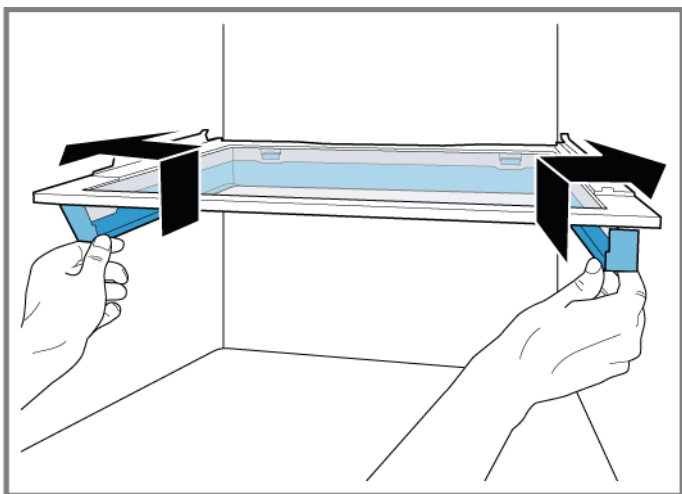

➡ I fermi laterali si sganciano.

2. Sollevare il telaio e farlo scorrere all'indietro.

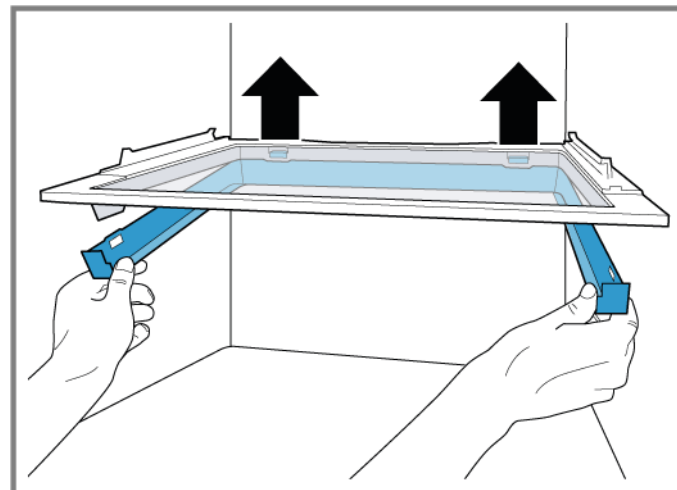

➡ I fermi posteriori si sganciano.

3. Togliere il telaio.
4. Sollevare il ripiano sopra il cassetto frutta e verdura e girarlo di lato.

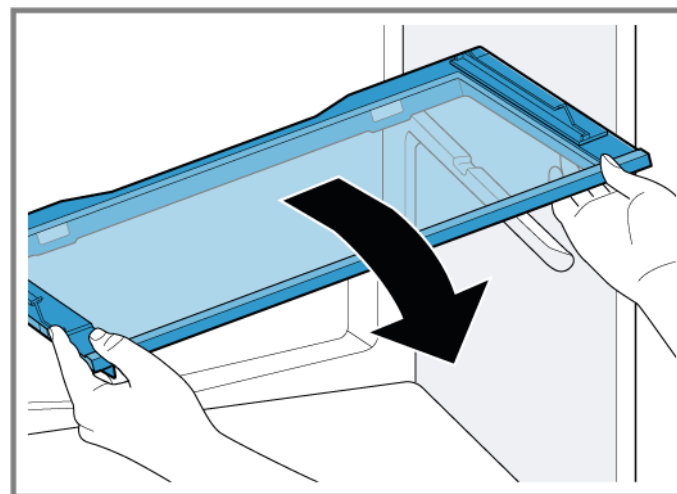

➡ Il ripiano sopra il cassetto frutta e verdura è rimosso.

4.12.2 Inserimento del ripiano sopra il cassetto frutta e verdura

- ▶ Per il montaggio, seguire la procedura sopra descritta in senso opposto.

4.13 Sostituzione del cassetto surgelati

Prerequisiti:

- ✔ La porta è aperta.

4.13.1 Rimozione del cassetto surgelati

- ▶ 1. Estrarre completamente il cassetto surgelati (1).
- ▶ 2. Togliere il cassetto surgelati (2).

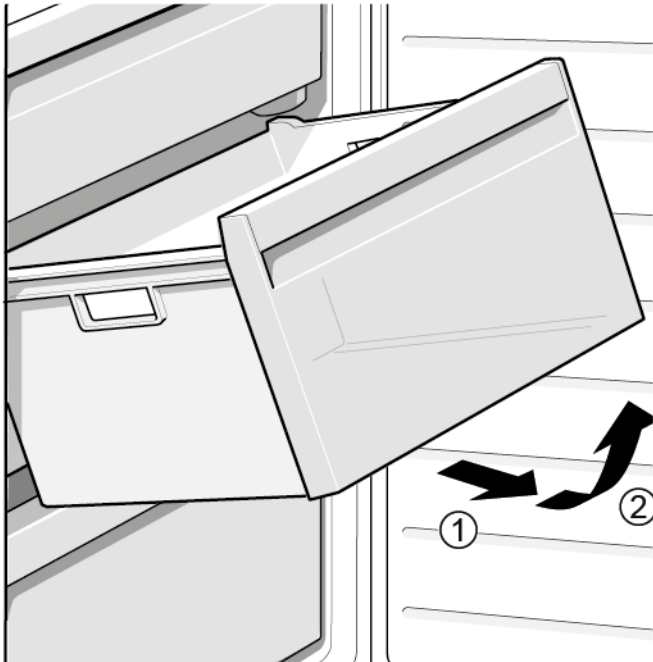

- ➡ Il cassetto surgelati è rimosso.

4.13.2 Inserimento del cassetto surgelati

- ▶ Per il montaggio, seguire la procedura sopra descritta in senso opposto.

4.14 Sostituzione della luce superiore a LED

Attrezzi speciali:

Utensile speciale [00342180]



L'apparecchio è dotato di una luce a LED esente da manutenzione. Queste luci possono essere riparate esclusivamente dal servizio assistenza tecnica o da tecnici autorizzati!



PERICOLO

Rischio di scosse elettriche dovute a componenti sotto tensione!
Pericolo di morte dovuto a scosse elettriche in caso di riparazione non conforme

- ▶ Le parti elettriche devono essere riparate da elettricisti qualificati.
- ▶ Ultimata la riparazione, occorre eseguire un test di sicurezza conforme alla norma VDE 0701 o alle norme specifiche del Paese.



PERICOLO

Rischio di scossa elettrica dovuto a componenti sotto tensione!
Morte per folgorazione

- ▶ Scollegare l'apparecchio dall'alimentazione per almeno 60 secondi prima di iniziare la riparazione.



ATTENZIONE

Bordi taglienti!
Ferite da taglio

- ▶ Indossare guanti di protezione.

Prerequisiti:

- ✓ L'apparecchio è scollegato dalla rete elettrica.
- ✓ La porta è aperta.

4.14.1 Smontaggio della luce superiore a LED

1. Far scorrere l'attrezzo di smontaggio tra la luce superiore a LED e il rivestimento interno del comparto frigorifero per sganciare i fermi (1).
2. Rimuovere la luce superiore a LED (2).

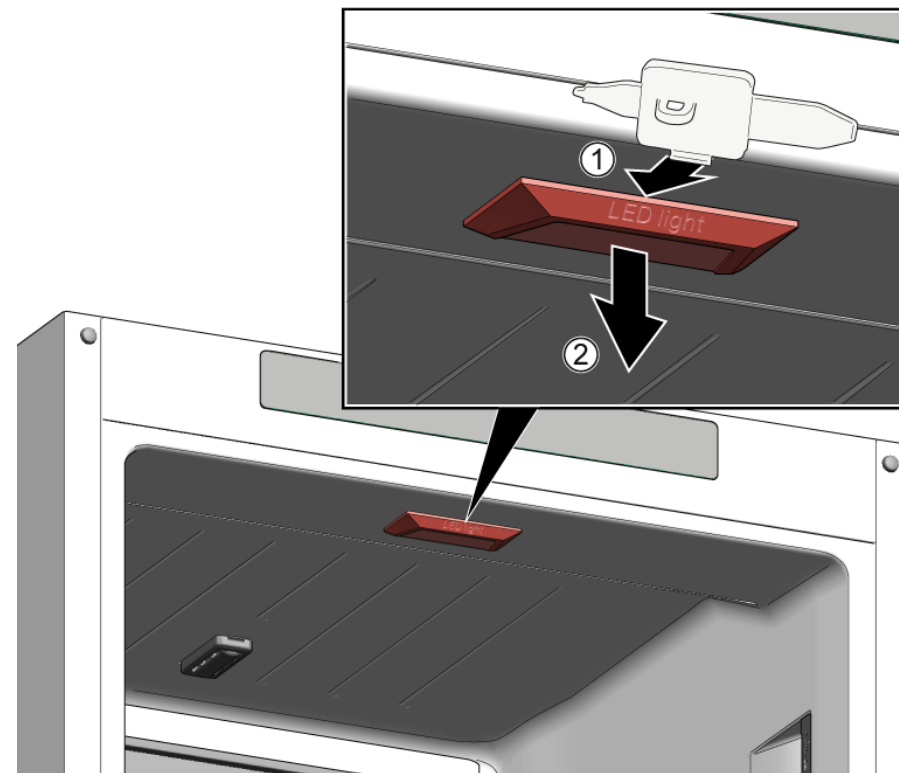

2. Staccare il collegamento elettrico della luce superiore a LED.
- ➡ La luce superiore a LED è rimossa.

4.14.2 Montaggio della luce superiore a LED

- ▶ Per il montaggio, seguire la procedura sopra descritta in senso opposto.

4.15 Sostituzione della luce laterale a LED

Attrezzi speciali:

Utensile speciale [00342180]

i L'apparecchio è dotato di luci LED esenti da manutenzione. Queste luci possono essere riparate esclusivamente dal servizio assistenza tecnica o da tecnici autorizzati!

⚠ PERICOLO
Rischio di scosse elettriche dovute a componenti sotto tensione!
 Pericolo di morte dovuto a scosse elettriche in caso di riparazione non conforme

- ▶ Le parti elettriche devono essere riparate da elettricisti qualificati.
- ▶ Ultimata la riparazione, occorre eseguire un test di sicurezza conforme alla norma VDE 0701 o alle norme specifiche del Paese.

⚠ PERICOLO
Rischio di scossa elettrica dovuto a componenti sotto tensione!
 Morte per folgorazione

- ▶ Scollegare l'apparecchio dall'alimentazione per almeno 60 secondi prima di iniziare la riparazione.

⚠ ATTENZIONE
Bordi taglienti!
 Ferite da taglio

- ▶ Indossare guanti di protezione.

⚠ ATTENZIONE!
Rischio di danneggiamento di componenti sensibili a carica elettrostatica (ESD)!
 Danneggiamento dei componenti

- ▶ Prima di toccare i componenti sensibili a carica elettrostatica, utilizzare un sistema di protezione dalle cariche elettrostatiche (bracciale con collegamento a terra).
- ▶ Non toccare i collegamenti e le piste conduttive dei moduli.
- ▶ Trasportare i componenti sensibili a carica elettrostatica solo in materiali conduttivi o imballaggi originali.
- ▶ Tenere i componenti sensibili a carica elettrostatica lontano da materiali a carica elettrostatica (ad es. plastica).

Prerequisiti:

- ✓ L'apparecchio è scollegato dalla rete elettrica.
- ✓ La porta è aperta.
- ✓ Gli accessori interni del comparto frigorifero sono stati rimossi.

4.15.1 Smontaggio della luce laterale a LED

1. Far scorrere l'attrezzo di smontaggio tra il diffusore e l'alloggiamento per sbloccare il fermo (1).
2. Estrarre il diffusore (2).
3. Sbloccare gli altri fermi del diffusore procedendo allo stesso modo.

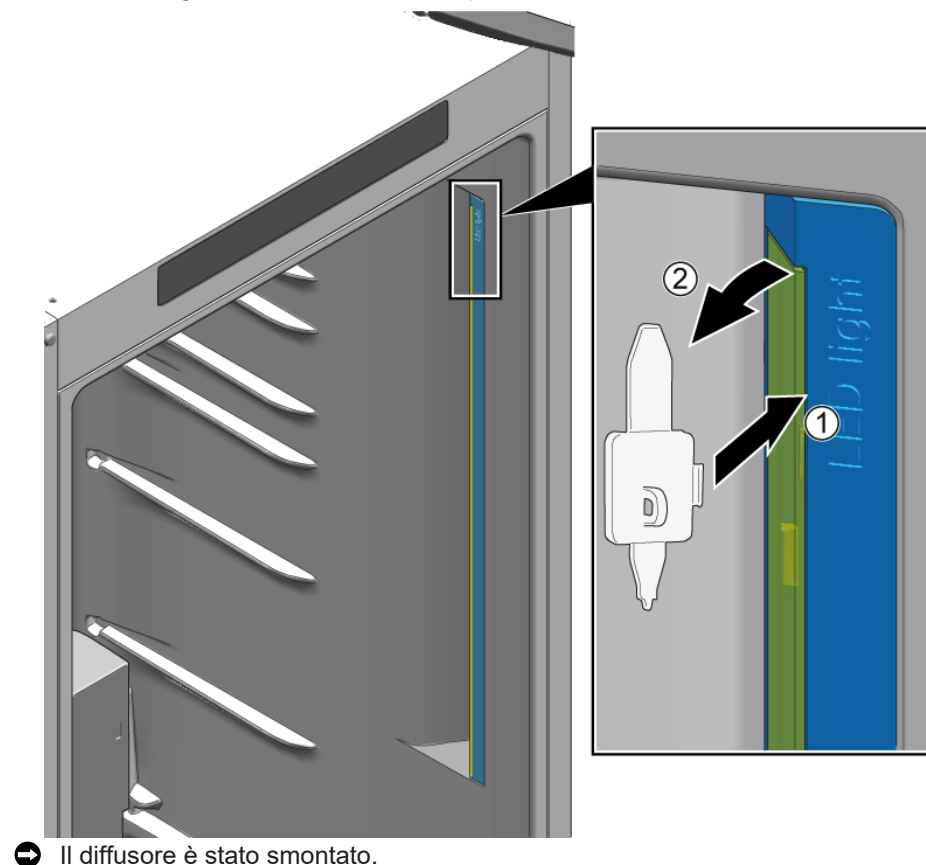

Riparazione

1. Premere sul fermo per sbloccarlo (1).
2. Spostare il modulo LED verso l'alto di ca. 1 cm per scollegarlo dalla presa elettrica (2).
3. Rimuovere il modulo LED (3).

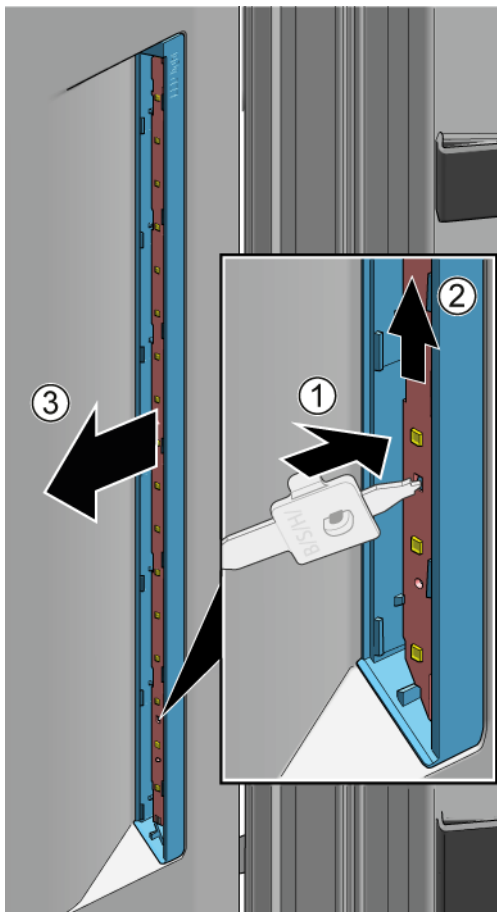

 La luce laterale LED è stata rimossa.

4.15.2 Montaggio della luce laterale a LED



Poiché i fermi del diffusore si rompono facilmente durante lo smontaggio, il kit ricambi della luce laterale LED comprende il modulo LED e il diffusore.

1. Far scorrere l'attrezzo di smontaggio tra il diffusore e l'alloggiamento per sbloccare il fermo (1).
2. Estrarre il diffusore (2).
3. Sbloccare gli altri fermi del diffusore procedendo allo stesso modo.

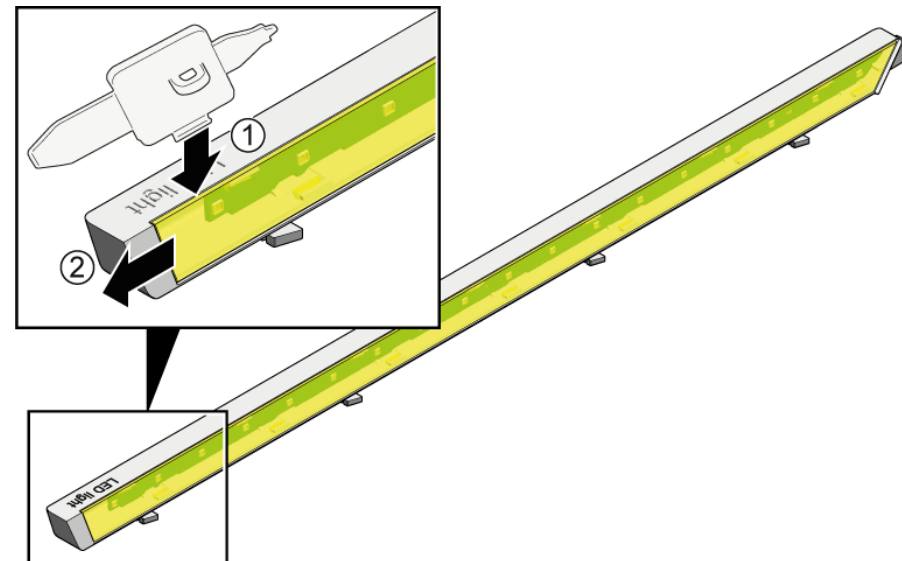

Riparazione

1. Premere sul fermo per sbloccarlo (1).
2. Far scorrere il modulo LED verso l'alto per toglierlo dall'alloggiamento.
3. Smaltire l'alloggiamento del modulo LED utilizzato per il trasporto in sicurezza dei ricambi (3).

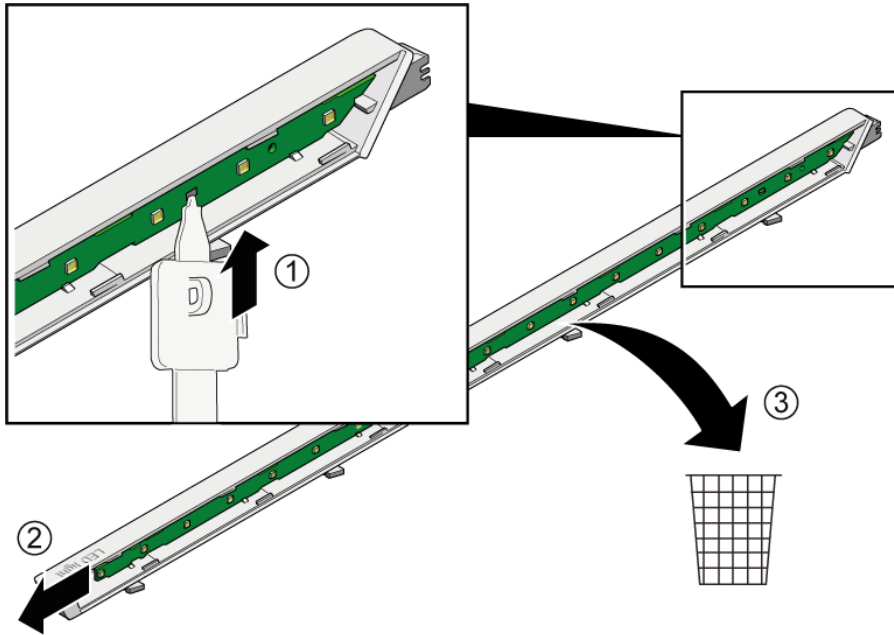

3. Montare il modulo LED e il diffusore un ordine inverso rispetto allo smontaggio.

4.16 Sostituzione della luce a LED del congelatore

Attrezzi speciali:

Utensile speciale [00342180]

i L'apparecchio è dotato di una luce a LED esente da manutenzione. Queste luci possono essere riparate esclusivamente dal servizio assistenza tecnica o da tecnici autorizzati!

⚠ PERICOLO
Rischio di scosse elettriche dovute a componenti sotto tensione!
 Pericolo di morte dovuto a scosse elettriche in caso di riparazione non conforme

- ▶ Le parti elettriche devono essere riparate da elettricisti qualificati.
- ▶ Ultimata la riparazione, occorre eseguire un test di sicurezza conforme alla norma VDE 0701 o alle norme specifiche del Paese.

⚠ PERICOLO
Rischio di scossa elettrica dovuto a componenti sotto tensione!
 Morte per folgorazione

- ▶ Scollegare l'apparecchio dall'alimentazione per almeno 60 secondi prima di iniziare la riparazione.

⚠ ATTENZIONE
Bordi taglienti!
 Ferite da taglio

- ▶ Indossare guanti di protezione.

Prerequisiti:

- ✓ L'apparecchio è scollegato dalla rete elettrica.
- ✓ La porta è aperta.

4.16.1 Smontaggio della luce a LED del congelatore

- ▶ 1. Far scorrere l'attrezzo di smontaggio tra la luce e l'alloggiamento a lato della luce per creare una fessura (1).
- ▶ 2. Far scorrere l'attrezzo di smontaggio sull'altro lato del fermo della luce e ruotarlo in avanti (2).
- ▶ 3. Rimuovere la luce a LED del congelatore (3).

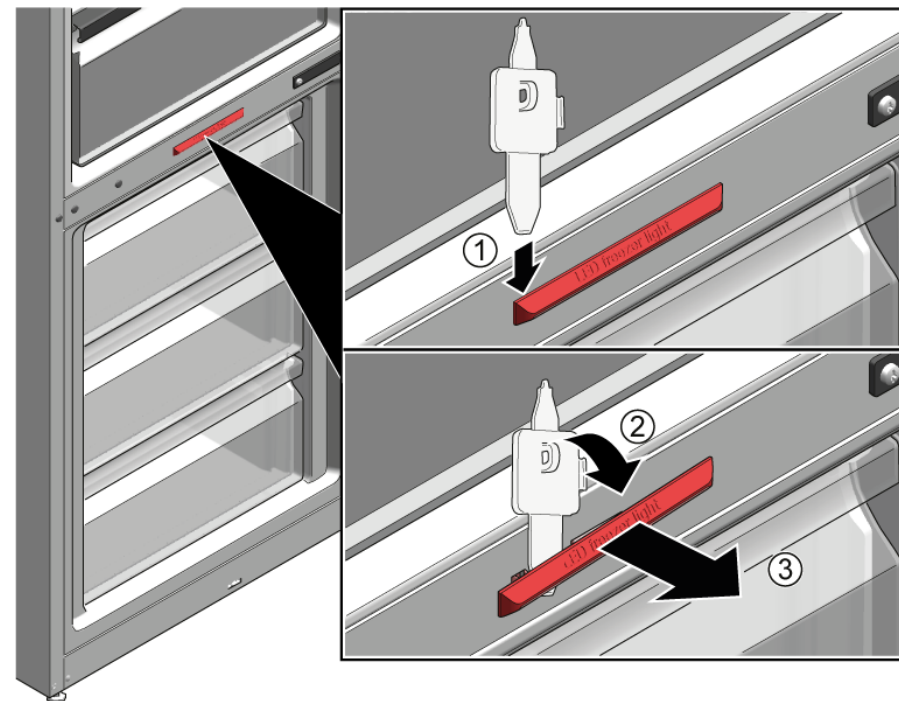





- ➡ La luce a LED del congelatore è scollegata.
- ➡ La luce a LED del congelatore è rimossa.

4.16.2 Montaggio della luce a LED del congelatore

- ▶ Per il montaggio, seguire la procedura sopra descritta in senso opposto.

Informācija par remontu - Dzesēšanas un saldēšanas kombinācija

 Par šo dokumentu	390	4.8 Pudeļu plaukta nomaiņa	406
1.1 Būtiska informācija	390	4.8.1 Pudeļu plaukta izņemšana	406
1.1.1 Mērķis	390	4.8.2 Pudeļu plaukta uzstādīšana	406
1.2 Simbolu skaidrojums.....	390	4.9 Durvju plaukta nomaiņa.....	407
1.2.1 Bīstamības līmeņi	390	4.9.1 Durvju plaukta noņemšana.....	407
1.2.2 Bīstamības simboli.....	390	4.9.2 Durvju plaukta uzstādīšana	407
1.2.3 Brīdinājumu struktūra	391	4.10 Uzglabāšanas tvertnes nomaiņa	408
1.2.4 Vispārīgie simboli.....	391	4.10.1 Uzglabāšanas tvertnes izņemšana	408
 Drošība	392	4.10.2 Uzglabāšanas tvertnes uzstādīšana	408
2.1 Vispārējie drošības norādījumi	392	4.11 Augļu un dārzeņu tvertnes nomaiņa	409
2.1.1 Visām mājtsaimniecības ierīcēm	392	4.11.1 Augļu un dārzeņu tvertnes izņemšana	409
 Piederumi un palīgļīdzekļi	393	4.11.2 Augļu un dārzeņu tvertnes uzstādīšana	409
 Remonts	394	4.12 Plaukta nomaiņa virs augļu un dārzeņu tvertnes	410
4.1 Durvju blīvslēga nomaiņa	394	4.12.1 Plaukta izņemšana virs augļu un dārzeņu tvertnes	410
4.1.1 Durvju blīvslēga noņemšana	394	4.12.2 Plaukta uzstādīšana virs augļu un dārzeņu tvertnes	411
4.1.2 Durvju blīvslēga uzstādīšana	394	4.13 Saldētās pārtikas tvertnes nomaiņa.....	412
4.2 Durvju roktura nomaiņa.....	397	4.13.1 Saldētās pārtikas tvertnes izņemšana	412
4.2.1 Durvju roktura noņemšana.....	397	4.13.2 Saldētās pārtikas tvertnes uzstādīšana	412
4.2.2 Durvju roktura uzstādīšana	397	4.14 Augšējās LED spuldzes nomaiņa	413
4.3 Durvju augšējās viras nomaiņa.....	398	4.14.1 Augšējās LED spuldzes izņemšana	413
4.3.1 Durvju augšējās viras noņemšana.....	398	4.14.2 Augšējās LED spuldzes uzstādīšana	413
4.3.2 Durvju augšējās viras uzstādīšana	399	4.15 Sānu LED spuldzes nomaiņa	414
4.4 Durvju augšējās viras nomaiņa (durvis ar displeju)	400	4.15.1 Sānu LED spuldzes izņemšana	414
4.4.1 Durvju augšējās viras noņemšana.....	400	4.15.2 Sānu LED spuldzes uzstādīšana	415
4.4.2 Durvju augšējās viras uzstādīšana	401	4.16 Saldētavas LED spuldzes nomaiņa	417
4.5 Durvju vidējās viras nomaiņa	402	4.16.1 Saldētavas LED spuldzes izņemšana	417
4.5.1 Durvju vidējās viras noņemšana.....	402	4.16.2 Saldētavas LED spuldzes uzstādīšana	417
4.5.2 Durvju vidējās viras uzstādīšana	403		
4.6 Durvju apakšējās viras nomaiņa	404		
4.6.1 Durvju apakšējās viras noņemšana	404		
4.6.2 Durvju apakšējās viras uzstādīšana	404		
4.7 Plaukta nomaiņa.....	405		
4.7.1 Plaukta izņemšana	405		
4.7.2 Plaukta uzstādīšana	405		

i Par šo dokumentu

1.1 Būtiska informācija

1.1.1 Mērķis

Šie labošanas ieteikumi ir paredzēti patērētājam, patstāvīgi labojot ierīces, saskaņā ar piemērojamo Ekodizaina regulu (sākot no 03.2021.).



Tajā ir sniegta informācija par to, kā nomainīt noteiktas rezerves daļas, kā arī brīdinājumi un riski.

Jautājumu gadījumā lūdzam sazināties ar mūsu klientu apkalpošanas dienestu. Mēs esam atbildīgi par zaudējumiem tikai tad, ja ir pienācīgi ievēroti šie labošanas ieteikumi.

1.2 Simbolu skaidrojums

1.2.1 Bīstamības līmeņi

Brīdinājuma līmeņus veido simbols un signālvārds. Signālvārds apzīmē bīstamības pakāpi.





Brīdinājuma līmenis	Nozīme
 BĪSTAMI	Brīdinājuma paziņojuma neievērošanas rezultātā iestāsies nāve vai radīsies smagas traumas.
 BRĪDINĀJUMS	Brīdinājuma paziņojuma neievērošanas rezultātā var iestāties nāve vai rasties smagas traumas.
 ESIET PIESARDŽĪGI	Brīdinājuma paziņojuma neievērošanas rezultātā var rasties nelielas traumas.
UZMANĪBU!	Brīdinājuma paziņojuma neievērošanas rezultātā var rasties kaitējums īpašumam.

Tabula 1: Bīstamības līmeņi



1.2.2 Bīstamības simboli

Bīstamības simboli ir simboliski apzīmējumi, kas sniedz norādes par bīstamības veidu.

Šajā dokumentā ir izmantoti šādi bīstamības simboli:

Bīstamības simbols	Nozīme
	Vispārējs brīdinājuma paziņojums
	Elektriskā sprieguma radīts apdraudējums
	Sprādzienbīstamības risks
	Griezumu bīstamība
	Saspiešanas bīstamība

i Par šo dokumentu

Bīstamības simbols	Nozīme
	Karstu virsmu radīta bīstamība
	Spēcīgu magnētisko lauku radīta bīstamība
	Nejonizējoša starojuma radīta bīstamība

Tabula 2: Bīstamības simboli

1.2.3 Brīdinājumu struktūra

Šajā dokumentā sniegtajiem brīdinājumiem ir standartizēts noformējums un standartizēta struktūra.



	<p>⚠ BĪSTAMI</p> <p>Bīstamības veids un avots! Iespējamās sekas, kas rodas, neievērojot bīstamības paziņojumu / brīdinājumu.</p> <ul style="list-style-type: none"> ▶ Bīstamības novēršanas pasākumi un aizliegumi.
--	--





Nākamajā piemērā ir parādīts brīdinājums, kas apzīmē elektrotrieciena risku, ko rada spriegumaktīvas detaļas. Ir norādīts bīstamības novēršanas pasākums.

	<p>⚠ BĪSTAMI</p> <p>Elektrotrieciena risks, ko rada spriegumaktīvas detaļas! Nāvējošs elektrotrieciens</p> <ul style="list-style-type: none"> ▶ Atvienojiet iekārtas no strāvas padeves vismaz 60 sekundes pirms labošanas sākšanas.
--	---

1.2.4 Vispārīgie simboli

Šajā dokumentā ir izmantoti šādi vispārīgie simboli:

Visp. simbols	Nozīme
	Īpašu ieteikumu apzīmējums (teksts un/ vai grafika)
	Vienkāršu ieteikumu apzīmējums (tikai teksts)

Visp. simbols	Nozīme
	Video pamācības saites apzīmējums
	Nepieciešamo rīku apzīmējums
	Nepieciešamo priekšnosacījumu apzīmējums
	Nosacījuma apzīmējums (ja ..., tad ...)
	Rezultāta apzīmējums
[Sākt]	Taustiņa vai pogas apzīmējums
[00123456]	Materiāla numura apzīmējums
Statuss	Attēlotā teksta / loga apzīmējums (iekārtas displejā)

Tabula 3: Vispārīgie simboli

2.1 Vispārējie drošības norādījumi

2.1.1 Visām mājsaimniecības ierīcēm

Elektrotrieciena risks spriegumaktīvu daļu dēļ!

- Ja remonts, kas skar elektriskās daļas, ir veikts kļūdaini, pastāv elektrotrieciena risks!
- Ierīcei ir jābūt atvienotai no tīkla vismaz 60 sekundes, pirms sāk darbu.
- Pēc remonta ierīces drošība ir jāpārbauda atbilstīgi noteikumiem VDE 0701 vai valsts noteikumiem.

Savainojumu risks asu malu dēļ!

- Valkājiet aizsargcimdus.

Saspiešanas risks labošanas, uzturēšanas, traucējumu novēršanas un apkopes laikā, ko rada smagas un kustīgas detaļas

- Valkājiet aizsargapavus.
- Nostipriniet smagas detaļas, lai tās nenokristu.
- Neievietojiet ķermeņa daļas kustīgās detaļās.

Ierīces drošības / darbības traucējuma risks!

- Izmantojiet tikai oriģinālās rezerves daļas.

Pret elektrostatisko izlādi jutīgu daļu (ESDS) bojājuma risks!

- Neaiztieciet moduļus, ieskaitot savienojumus un vadojumu.

Piederumi un palīglīdzekļi

Apzīmējums	Sīkāka informācija	Attēli
Torx uzgalis TX20 [00340865]	6,3 mm (1/4")	
Īpašs darbarīks [00342180]		

4.1 Durvju blīvslēga nomaīņa

Prasība:

- ✔ Durvīm ir jābūt atvērtām.

4.1.1 Durvju blīvslēga noņemšana

1. Atbrīvojiet durvju blīvslēgu no rievas labajā un kreisajā pusē.

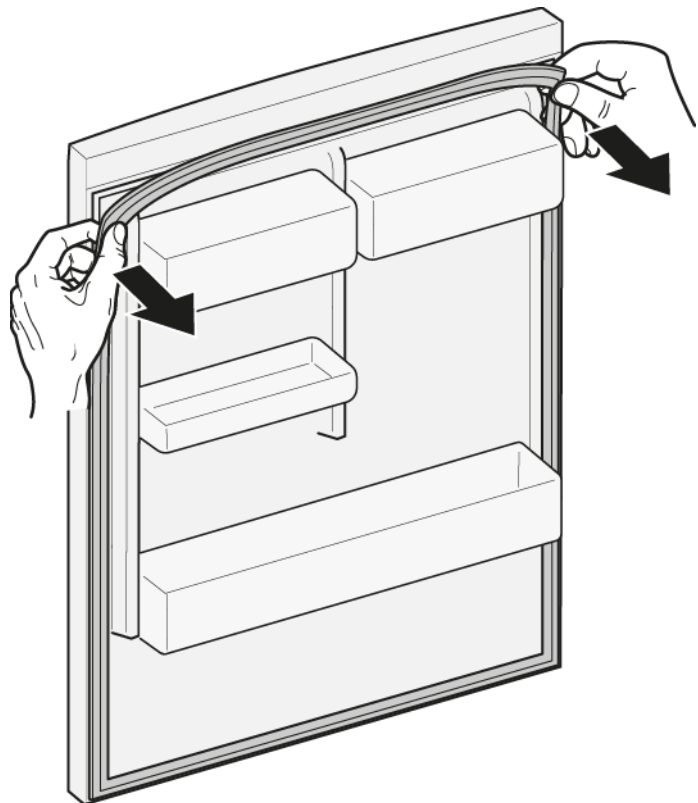

2. Izvelciet durvju blīvslēgu no rievas.

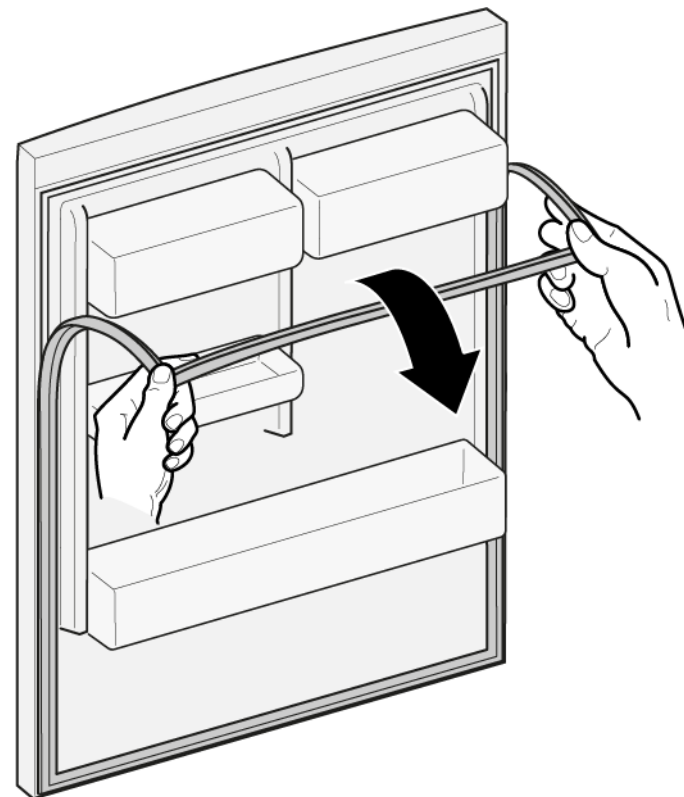

- ➡ Durvju blīvslēgs ir noņemts.

4.1.2 Durvju blīvslēga uzstādīšana



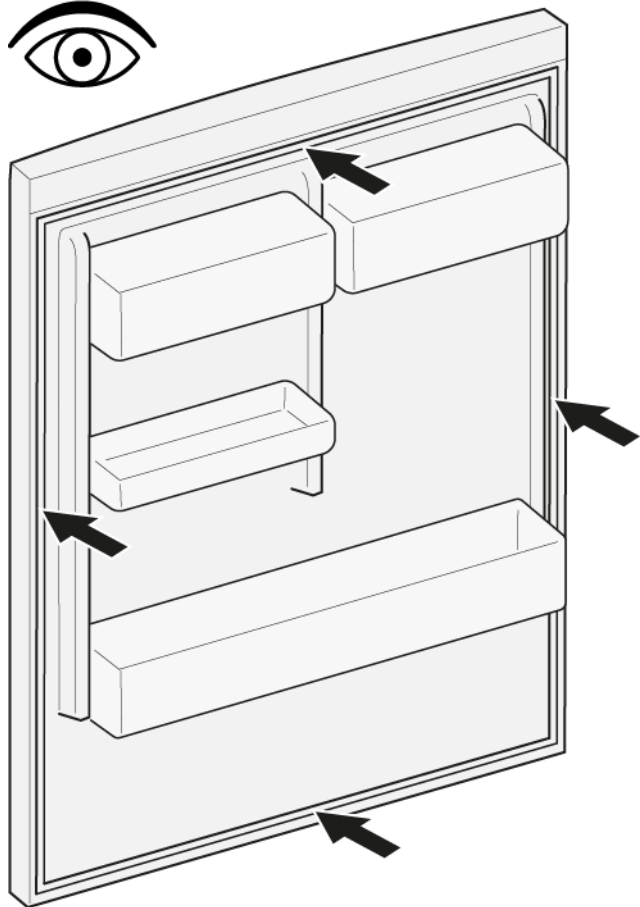

Jaunā durvju blīvslēga biezums var mazliet atšķirties no vecā durvju blīvslēga biezuma. Tas neietekmē aizvēršanos un darbību ilgtermiņā. Ja ierīces viras var regulēt vai tai ir viru savienojumi, vēlāk aizvēršanos var pielāgot. Mazie caurumi durvju blīvslēga sānos ir funkcionāli (nodrošina ventilāciju). Tie nav ražošanas defekti.

1. Pārbaudiet, ka blīvslēga rieta nav bojāta.

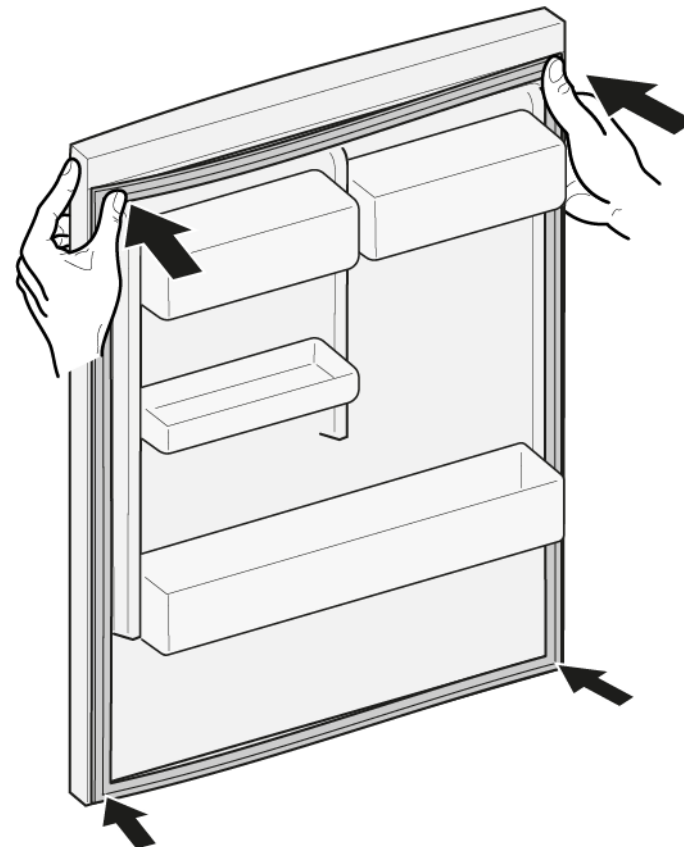

4. Iespiediet blīvslēga augšējos un apakšējos stūrus rievā.



2.  Ja blīvslēga rieta ir bojāta
- Sazinieties ar klientu apkalpošanas dienesta pārstāvi.

3.  Durvju blīvslēgs var būt mazliet deformējies, kas neietekmē tā darbību. Pirms durvju blīvslēgu ieliek ierīcē, to ir ieteicams iztaisnot.

Sasildiet durvju blīvslēgu ar matu fēnu vai karstā ūdenī un ar rokām atjaunojiet tā formu.

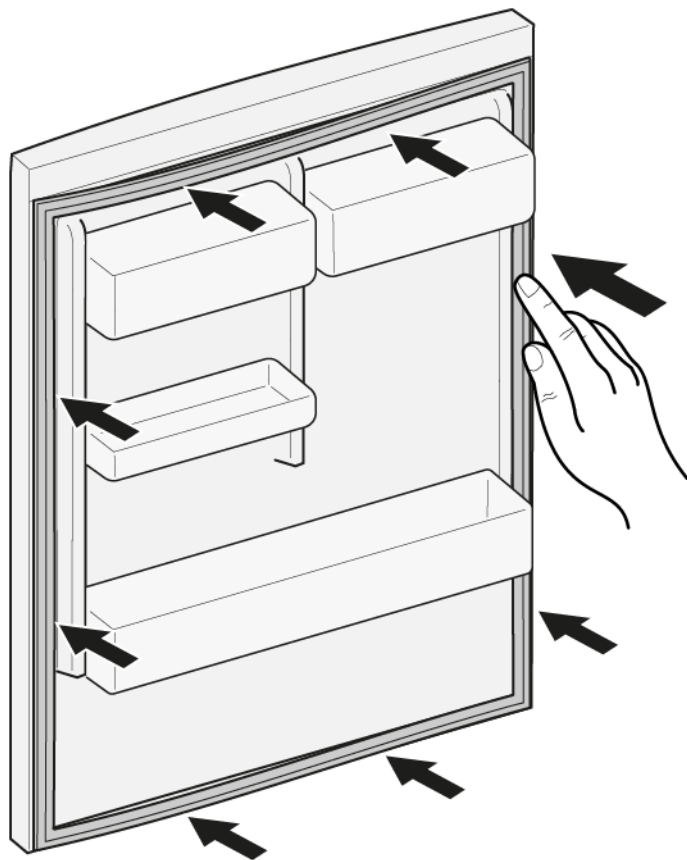

5. Pakāpeniski iespiediet visu blīvslēgu rievā.





 Durvju blīvslēgs ir uzstādīts.

4.2 Durvju roktura nomaiņa

Speciāli rīki:

-  Torx uzgalis TX20 6,3 mm (1/4") [00340865]
-  Plakanais skrūvgriezis Izmērs: 10 mm x 1,6 mm x 200 mm

Prasība:

-  Ierīces elektropadevei ir jābūt atvienotai.
-  Durvīm ir jābūt atvērtām.

4.2.1 Durvju roktura noņemšana

- ▶ 1. Noņemiet abu skrūvju vāciņus (1).
- ▶ 2. Izskrūvējiet abas skrūves (2).
- ▶ 3. Noņemiet durvju rokturi (3).

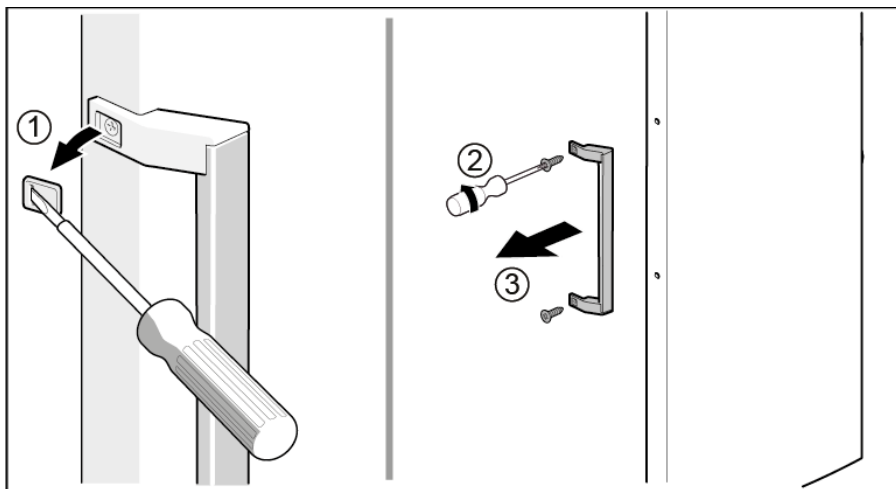

 Durvju rokturis ir noņemts.



Otru durvju rokturi noņem tāpat.

4.2.2 Durvju roktura uzstādīšana

- ▶ Uzstādiet apgrieztā kārtībā.

4.3 Durvju augšējās viras nomaiņa

Speciāli rīki:

Torx uzgalis TX20

6,3 mm (1/4")

[00340865]

	<p>BRĪDINĀJUMS</p> <p>Smaga lielizmēra ierīce! Muguras un muskuļu savainojumi</p> <ul style="list-style-type: none"> ▶ Ierīces durvis drīkst noņemt tikai apmācīts speciālists. ▶ Ierīce ir jāpārvieta divatā. ▶ Ir jāizmanto tikai piemēroti darbarīki un aprīkojums.
	<p>ESIET PIESARDZĪGI</p> <p>Asas malas! Grieztas brūces</p> <ul style="list-style-type: none"> ▶ Lietojiet aizsargcimdus.
	<p>BRĪDINĀJUMS</p> <p>Sasvērušos ierīču paslīdēšana! Kaulu lūzumi / saspiešanas traumas</p> <ul style="list-style-type: none"> ▶ Nostipriniet ierīces, lai tās neslīdētu.
	<p>ESIET PIESARDZĪGI</p> <p>Krītošu detaļu risks, ko izraisa vaļīgās skrūves! Krītošu detaļu izraisītas traumas.</p> <ul style="list-style-type: none"> ▶ Nostipriniet detaļu, lai tā nenokristu.
	<p>UZMANĪBU!</p> <p>Krītošu detaļu risks, ko izraisa vaļīgās skrūves! Citu ierīces detaļu bojājumi vai bojājumi, kas rodas klienta mājās, piem., apakšpuse.</p> <ul style="list-style-type: none"> ▶ Nostipriniet detaļu, lai tā nenokristu.

Prasība:

- ✓ Ierīces elektropadevei ir jābūt atvienotai.
- ✓ Ierīces iekšējām daļām ir jābūt izņemtām.

4.3.1 Durvju augšējās viras noņemšana

1. Pabīdiet balsta daļu zem pamatnes sekcijas.

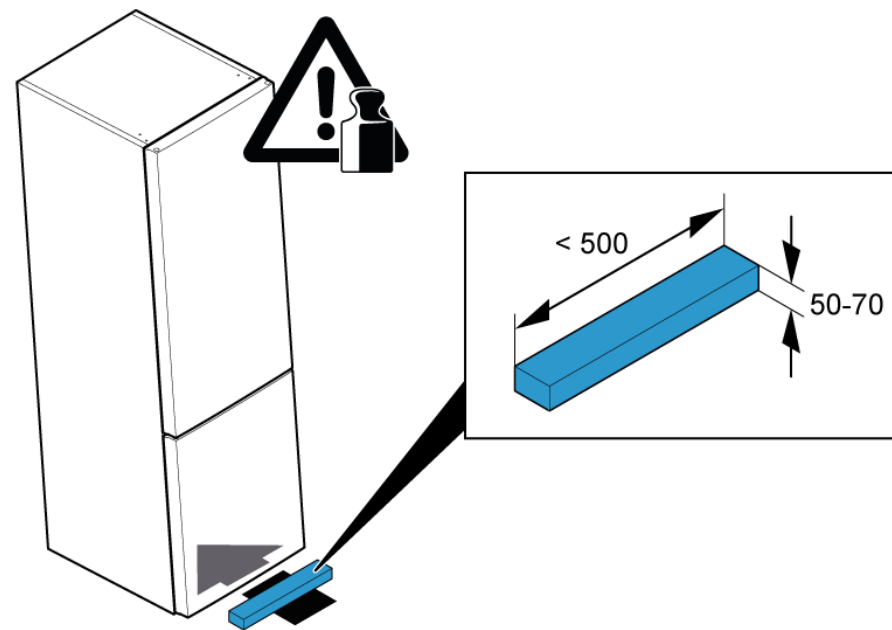

2. 1. Noņemiet augšējās viras pārsegu (1).
2. Izskrūvējiet abas skrūves (2).
3. Noņemiet augšējo viru (3).

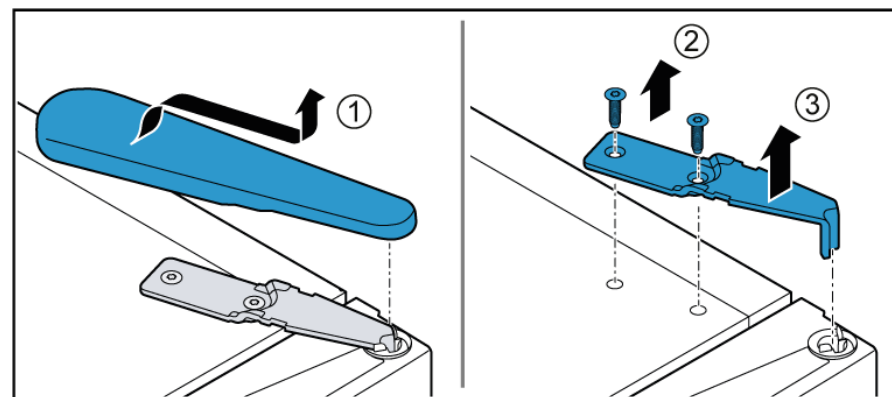

3. Noņemiet augšējās durvis.

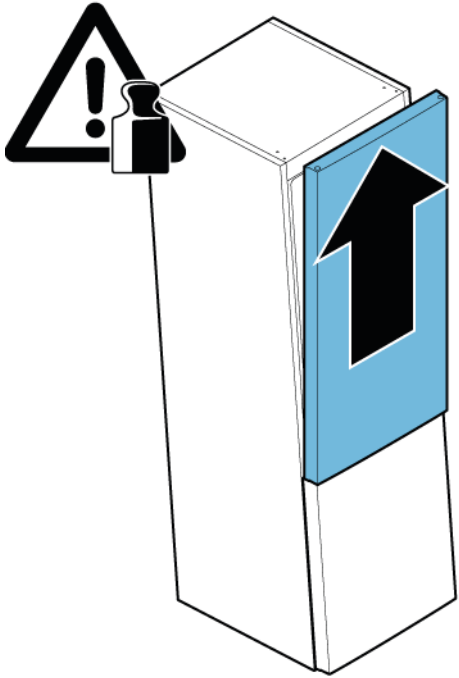

 Augšējā vira ir noņemta.

4.3.2 Durvju augšējās viras uzstādīšana

► Uzstādiet apgrieztā kārtībā.

4.4 Durvju augšējās viras nomaiņa (durvis ar displeju)

Speciāli rīki:

Torx uzgalis TX20 6,3 mm (1/4") [00340865]

	⚠ BRĪDINĀJUMS
	<p>Smaga lielizmēra ierīce! Muguras un muskuļu savainojumi</p> <ul style="list-style-type: none"> ▶ Ierīces durvis drīkst noņemt tikai apmācīts speciālists. ▶ Ierīce ir jāpārvieta divatā. ▶ Ir jāizmanto tikai piemēroti darbarīki un aprīkojums.

	⚠ ESIET PIESARDZĪGI
	<p>Asas malas! Grieztas brūces</p> <ul style="list-style-type: none"> ▶ Lietojiet aizsargcimdus.

	⚠ BRĪDINĀJUMS
	<p>Sasvērušos ierīču paslīdēšana! Kaulu lūzumi / saspiešanas traumas</p> <ul style="list-style-type: none"> ▶ Nostipriniet ierīces, lai tās neslīdētu.

	⚠ ESIET PIESARDZĪGI
	<p>Krītošu detaļu risks, ko izraisa vaļīgas skrūves! Krītošu detaļu izraisītas traumas.</p> <ul style="list-style-type: none"> ▶ Nostipriniet detaļu, lai tā nenokristu.

	UZMANĪBU!
	<p>Krītošu detaļu risks, ko izraisa vaļīgas skrūves! Citu ierīces detaļu bojājumi vai bojājumi, kas rodas klienta mājās, piem., apakšpuse.</p> <ul style="list-style-type: none"> ▶ Nostipriniet detaļu, lai tā nenokristu.

	⚠ BĪSTAMI
	<p>Elektrotrieciena risks spriegumaktīvu daļu dēļ! Dzīvības apdraudējums nepareiza remonta izraisīta elektrotrieciena dēļ</p> <ul style="list-style-type: none"> ▶ Elektriskās daļas ir jāremontē kvalificētam elektriķim. ▶ Pēc remonta ierīces drošība ir jāpārbauda atbilstīgi noteikumiem VDE 0701 vai valsts noteikumiem.

	⚠ BĪSTAMI
	<p>Elektrotrieciena risks, ko rada spriegumaktīvas detaļas! Nāvējošs elektrotrieciens</p> <ul style="list-style-type: none"> ▶ Atvienojiet iekārtas no strāvas padeves vismaz 60 sekundes pirms labošanas sākšanas.

Prasība:

- Ierīces elektropadevei ir jābūt atvienotai.
- Ierīces iekšējām daļām ir jābūt izņemtām.

4.4.1 Durvju augšējās viras noņemšana

1. Pabīdiet balsta daļu zem pamatnes sekcijas.

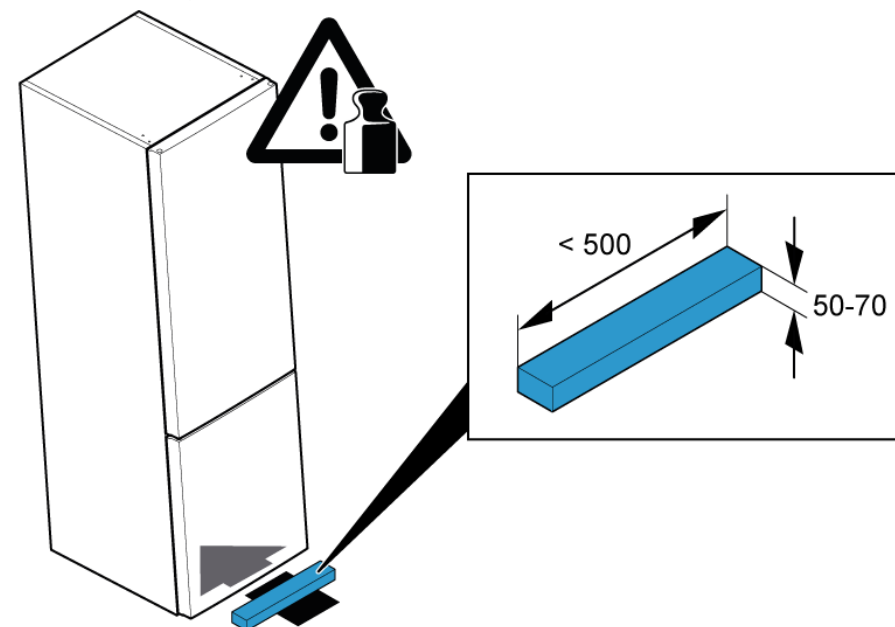

Remonts

1. Noņemiet augšējās viras pārsegu (1).
2. Atvienojiet elektrisko savienojumu (2).
3. Izskrūvējiet zemētājsavienojuma skrūvi (3).

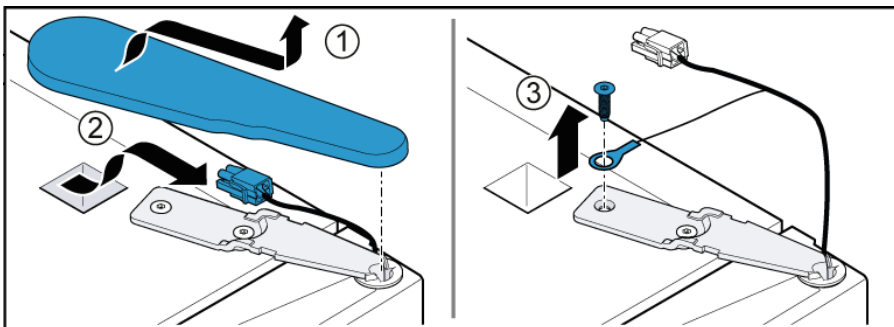

1. Izskrūvējiet skrūvi (1).
2. Noņemiet augšējo viru (2).

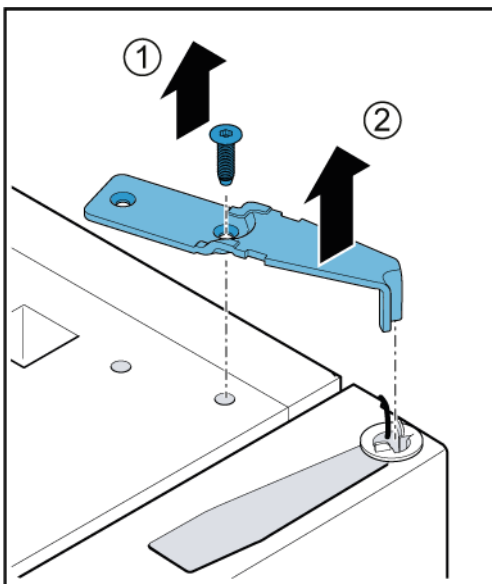

4. Noņemiet augšējās durvis.

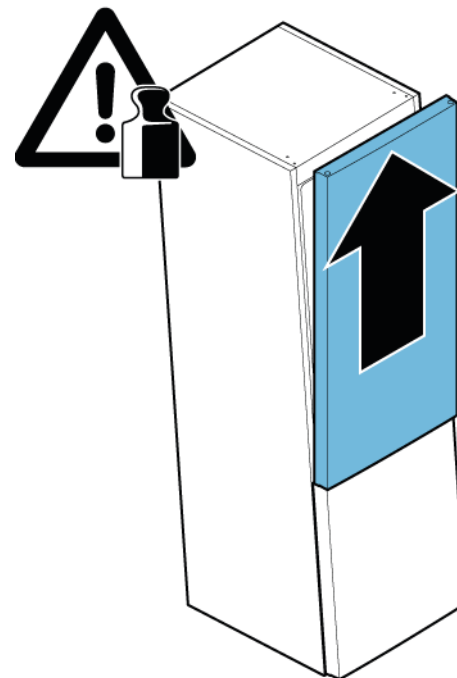

➔ Augšējā vira ir noņemta.

4.4.2 Durvju augšējās viras uzstādīšana

- ▶ Uzstādiet apgrieztā kārtībā.

4.5 Durvju vidējās viras nomaiņa

Speciāli rīki:

Torx uzgalis TX20

6,3 mm (1/4")

[00340865]

	<p>BRĪDINĀJUMS</p> <p>Smaga lielizmēra ierīce! Muguras un muskuļu savainojumi</p> <ul style="list-style-type: none"> ▶ Ierīces durvis drīkst noņemt tikai apmācīts speciālists. ▶ Ierīce ir jāpārvieta divatā. ▶ Ir jāizmanto tikai piemēroti darbarīki un aprīkojums.
	<p>ESIET PIESARDZĪGI</p> <p>Asas malas! Grieztas brūces</p> <ul style="list-style-type: none"> ▶ Lietojiet aizsargcimdus.
	<p>BRĪDINĀJUMS</p> <p>Sasvērušos ierīču paslīdēšana! Kaulu lūzumi / saspiešanas traumas</p> <ul style="list-style-type: none"> ▶ Nostipriniet ierīces, lai tās neslīdētu.
	<p>ESIET PIESARDZĪGI</p> <p>Krītošu detaļu risks, ko izraisa vaļīgas skrūves! Krītošu detaļu izraisītas traumas.</p> <ul style="list-style-type: none"> ▶ Nostipriniet detaļu, lai tā nenokristu.
	<p>UZMANĪBU!</p> <p>Krītošu detaļu risks, ko izraisa vaļīgas skrūves! Citu ierīces detaļu bojājumi vai bojājumi, kas rodas klienta mājās, piem., apakšpuse.</p> <ul style="list-style-type: none"> ▶ Nostipriniet detaļu, lai tā nenokristu.

Prasība:

- ✔ Ierīces elektropadevei ir jābūt atvienotai.
- ✔ Ierīces iekšējās daļas ir izņemtas.
- ✔ Durvju augšējā vira ir noņemta.
- ✔ Augšējās durvis ir noņemtas.

4.5.1 Durvju vidējās viras noņemšana

1. 1. Izskrūvējiet abas skrūves (1).
2. Noņemiet vidējo viru (2).

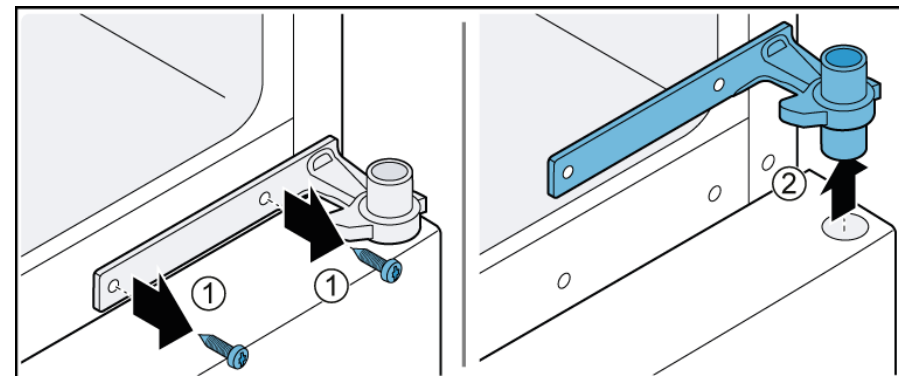

2. Noņemiet apakšējās durvis.

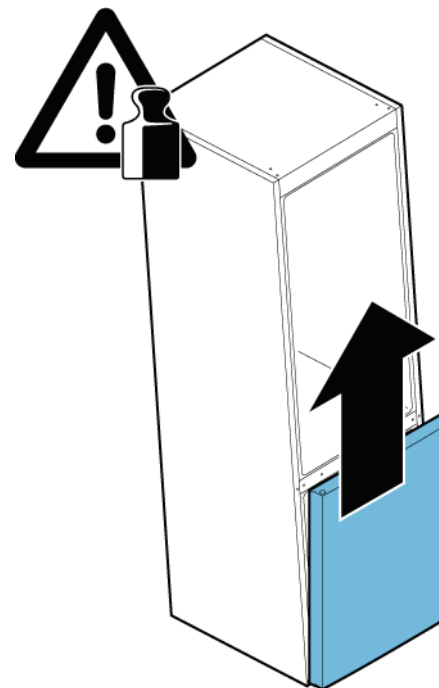

- ➡ Vidējā vira ir noņemta.

4.5.2 Durvju vidējās viras uzstādīšana

- ▶ Uzstādiet apgrieztā kārtībā.

4.6 Durvju apakšējās viras nomaiņa

Speciāli rīki:

Torx uzgalis TX20 6,3 mm (1/4") [00340865]

	<p>BRĪDINĀJUMS</p> <p>Smaga lielizmēra ierīce! Muguras un muskuļu savainojumi</p> <ul style="list-style-type: none"> ▶ Ierīces durvis drīkst noņemt tikai apmācīts speciālists. ▶ Ierīce ir jāpārvieta divatā. ▶ Ir jāizmanto tikai piemēroti darbarīki un aprīkojums.
	<p>ESIET PIESARDZĪGI</p> <p>Asas malas! Grieztas brūces</p> <ul style="list-style-type: none"> ▶ Lietojiet aizsargcimdus.
	<p>BRĪDINĀJUMS</p> <p>Sasvērušos ierīču paslīdēšana! Kaulu lūzumi / saspiešanas traumas</p> <ul style="list-style-type: none"> ▶ Nostipriniet ierīces, lai tās neslīdētu.
	<p>ESIET PIESARDZĪGI</p> <p>Krītošu detaļu risks, ko izraisa vaļīgās skrūves! Krītošu detaļu izraisītas traumas.</p> <ul style="list-style-type: none"> ▶ Nostipriniet detaļu, lai tā nenokristu.
	<p>UZMANĪBU!</p> <p>Krītošu detaļu risks, ko izraisa vaļīgās skrūves! Citu ierīces detaļu bojājumi vai bojājumi, kas rodas klienta mājās, piem., apakšpusē.</p> <ul style="list-style-type: none"> ▶ Nostipriniet detaļu, lai tā nenokristu.

Prasība:

- ✓ Ierīces elektropadevei ir jābūt atvienotai.
- ✓ Ierīces iekšējām daļām ir jābūt izņemtām.
- ✓ Augšējā vira ir noņemta.
- ✓ Vidējā vira ir noņemta.

4.6.1 Durvju apakšējās viras noņemšana

- ▶ 1. Izskrūvējiet abas skrūves (1).
- ▶ 2. Noņemiet apakšējo viru (2).

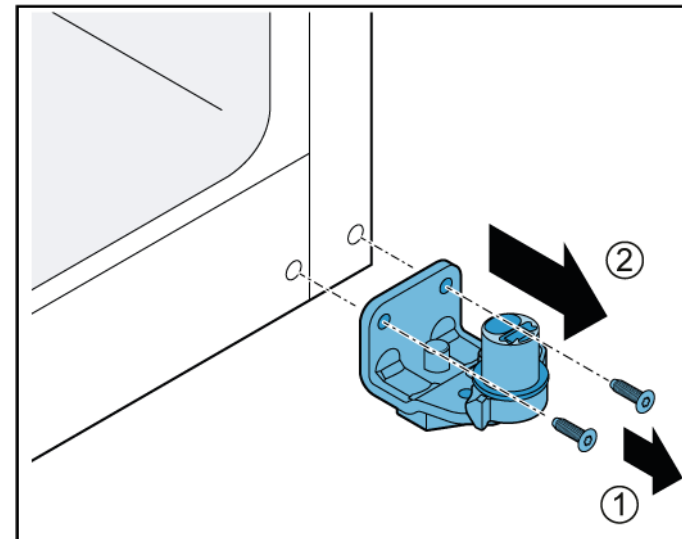

➡ Durvju apakšējā vira ir noņemta.

4.6.2 Durvju apakšējās viras uzstādīšana

- ▶ Uzstādiet apgrieztā kārtībā.

4.7 Plaukta nomaiņa

Prasība:

- ✔ Durvīm ir jābūt atvērtām.

4.7.1 Plaukta izņemšana

- ▶ 1. Paceliet plauktu aizmugurē (1).
- ▶ 2. Atbrīvojiet plauktu (2).

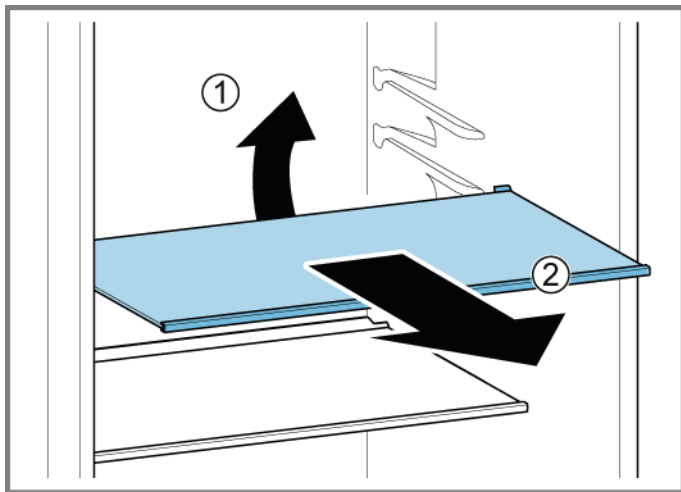

- ➡ Plaukts ir izņemts.

4.7.2 Plaukta uzstādīšana

- ▶ Uzstādiet apgrieztā kārtībā.

4.8 Pudeļu plaukta nomaiņa

Prasība:

- ✓ Durvīm ir jābūt atvērtām.

4.8.1 Pudeļu plaukta izņemšana

- ▶ Izvelciet pudeļu plauktu.

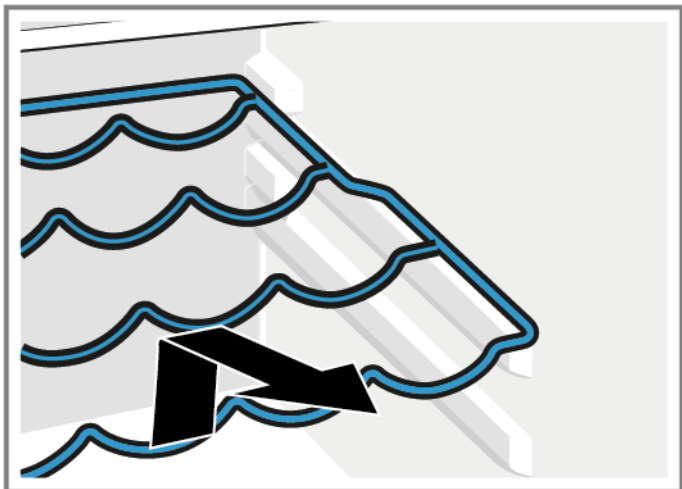

- ➡ Pudeļu plaukts ir izņemts.

4.8.2 Pudeļu plaukta uzstādīšana

- ▶ Uzstādiet apgrieztā kārtībā.

4.9 Durvju plaukta nomaiņa

Prasība:

- ✔ Durvīm ir jābūt atvērtām.

4.9.1 Durvju plaukta noņemšana

- ▶ Paceliet durvju plauktu uz augšu.

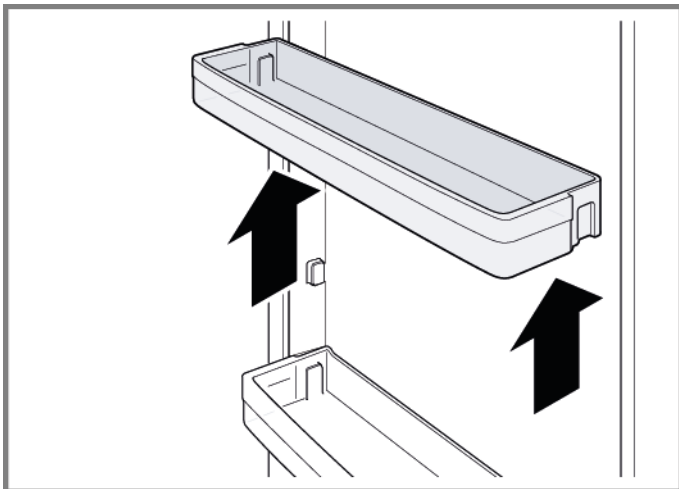

- ➡ Durvju plaukts ir noņemts.

4.9.2 Durvju plaukta uzstādīšana

- ▶ Uzstādiet apgrieztā kārtībā.

4.10 Uzglabāšanas tvertnes nomaiņa

Prasība:

- ✔ Durvīm ir jābūt atvērtām.

4.10.1 Uzglabāšanas tvertnes izņemšana

1. Izvelciet uzglabāšanas tvertni līdz atdurei.
2. 1. Paceliet uzglabāšanas tvertni priekšā (1).
2. Izņemiet tvertni (2).

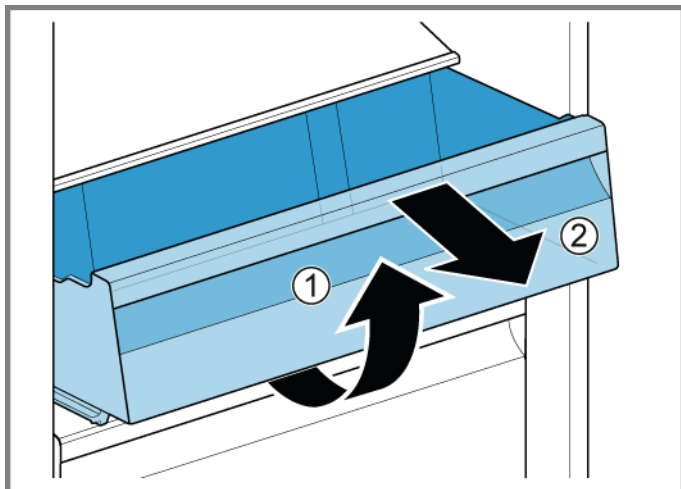

- ➡ Uzglabāšanas tvertne ir izņemta.

4.10.2 Uzglabāšanas tvertnes uzstādīšana

- ▶ Uzstādiet apgrieztā kārtībā.

4.11 Augļu un dārzeņu tvertnes nomaiņa

Prasība:

- ✔ Durvīm ir jābūt atvērtām.

4.11.1 Augļu un dārzeņu tvertnes izņemšana

1. Izvelciet augļu un dārzeņu tvertni līdz atdurei.
2. 1. Paceliet augļu un dārzeņu tvertni priekšā (1).
2. Izņemiet tvertni (2).

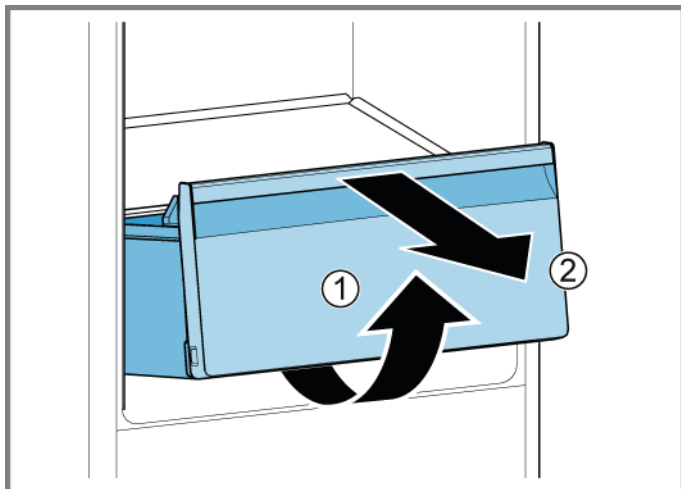

- ➡ Augļu un dārzeņu tvertne ir izņemta.

4.11.2 Augļu un dārzeņu tvertnes uzstādīšana

- ▶ Uzstādiet apgrieztā kārtībā.

4.12 Plaukta nomaiņa virs augļu un dārzeņu tvertnes

Prasība:

- ✓ Durvīm ir jābūt atvērtām.
- ✓ [Augļu un dārzeņu tvertne ir izņemta.](#) →409

4.12.1 Plaukta izņemšana virs augļu un dārzeņu tvertnes

1. Paceliet noslēdzošo rāmi uz augšu un izceliet ārā.

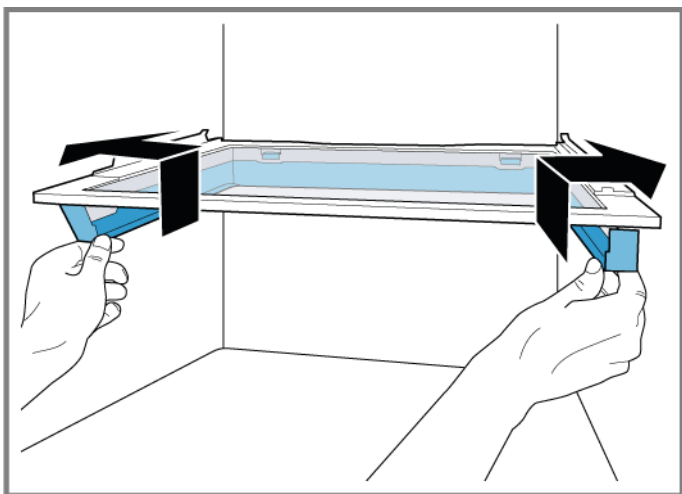

- ➡ Sānu āķi ir atbrīvoti.

2. Paceliet noslēdzošo rāmi un bīdiet to atpakaļ.

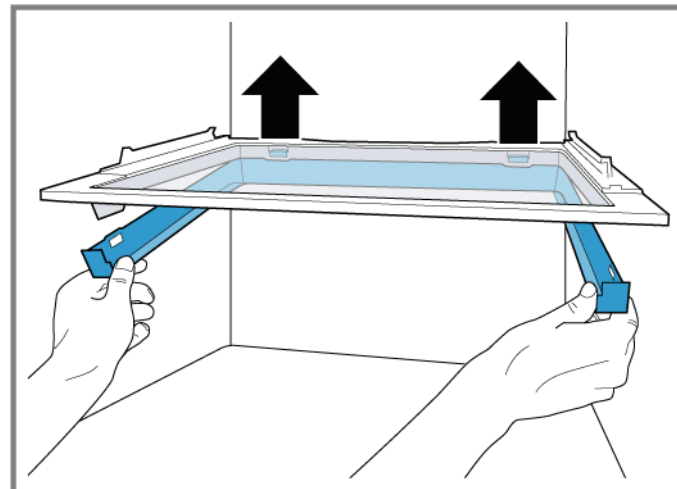

- ➡ Aizmugurējie āķi ir atbrīvoti.

3. Izņemiet noslēdzošo rāmi.
4. Paceliet plauktu virs augļu un dārzeņu tvertnes un sagāziet uz sāniem.

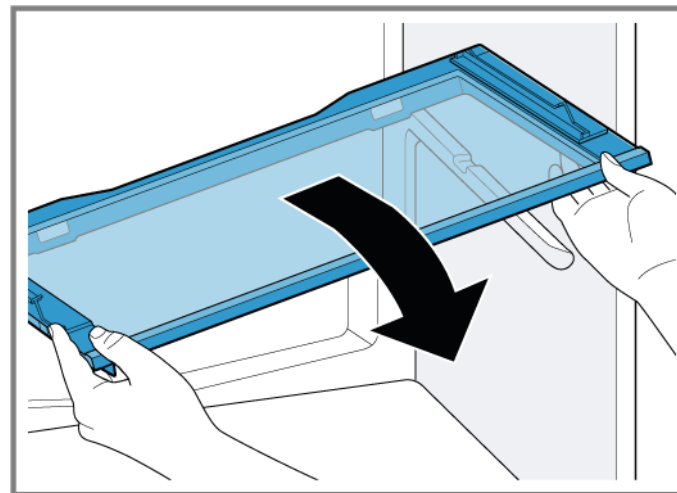

- ➡ Plaukts virs augļu un dārzeņu tvertnes ir izņemts.

4.12.2 Plaukta uzstādīšana virs augļu un dārzeņu tvertnes

- ▶ Uzstādiet apgrieztā kārtībā.

4.13 Saldētās pārtikas tvertnes nomaiņa

Prasība:

- ✔ Durvīm ir jābūt atvērtām.

4.13.1 Saldētās pārtikas tvertnes izņemšana

- ▶ 1. Pilnībā izvelciet saldētās pārtikas tvertni (1).
- ▶ 2. Izņemiet pārtikas tvertni (2).

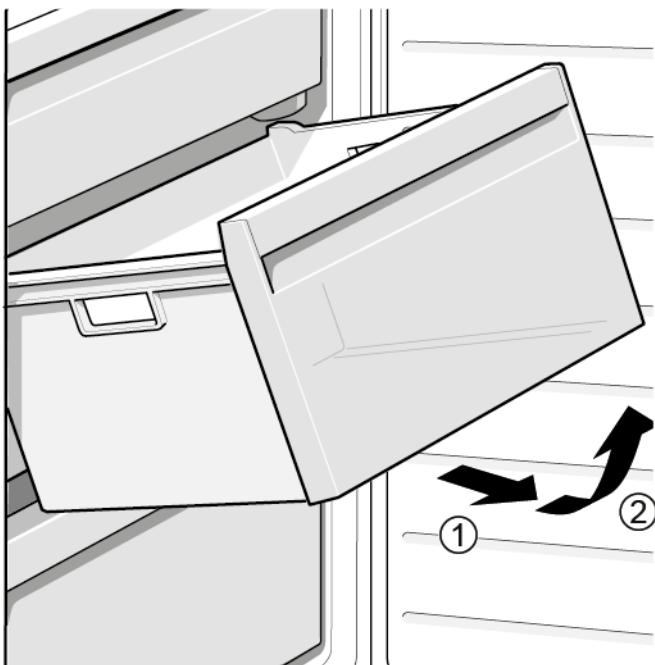

- ➡ Saldētās pārtikas tvertne ir izņemta.

4.13.2 Saldētās pārtikas tvertnes uzstādīšana

- ▶ Uzstādiet apgrieztā kārtībā.

4.14 Augšējās LED spuldzes nomaiņa

Speciāli rīki:

🔧 Īpašs darbarīks

[00342180]

	<p>Ierīcē ir LED gaismeklis, kam nav jāveic apkope.</p> <p>Šo gaismekli drīkst remontēt tikai klientu apkalpošanas dienesta pārstāvis vai pilnvarots tehniķis!</p>
---	--

	<p style="text-align: center;">⚠ BĪSTAMI</p> <p>Elektrotrieciena risks spriegumaktīvu daļu dēļ!</p> <p>Dzīvības apdraudējums nepareiza remonta izraisīta elektrotrieciena dēļ</p> <ul style="list-style-type: none"> ▶ Elektriskās daļas ir jāremontē kvalificētam elektriķim. ▶ Pēc remonta ierīces drošība ir jāpārbauda atbilstīgi noteikumiem VDE 0701 vai valsts noteikumiem.
--	--

	<p style="text-align: center;">⚠ BĪSTAMI</p> <p>Elektrotrieciena risks, ko rada spriegumaktīvas detaļas!</p> <p>Nāvējošs elektrotrieciens</p> <ul style="list-style-type: none"> ▶ Atvienojiet iekārtas no strāvas padeves vismaz 60 sekundes pirms labošanas sākšanas.
--	--

	<p style="text-align: center;">⚠ ESIET PIESARDZĪGI</p> <p>Asas malas!</p> <p>Grieztas brūces</p> <ul style="list-style-type: none"> ▶ Lietojiet aizsargcimdus.
---	---

Prasība:

- ✔ Ierīcei ir jābūt atvienotai no strāvas padeves.
- ✔ Durvīm ir jābūt atvērtām.

4.14.1 Augšējās LED spuldzes izņemšana

1. 1. Iebīdīet demontāžas instrumentu starp augšējo LED spuldzi un ledusskapja nodalījuma iekšējo apdari, lai atbrīvotu spuldzes āķus (1).
2. Izņemiet augšējo LED spuldzi (2).

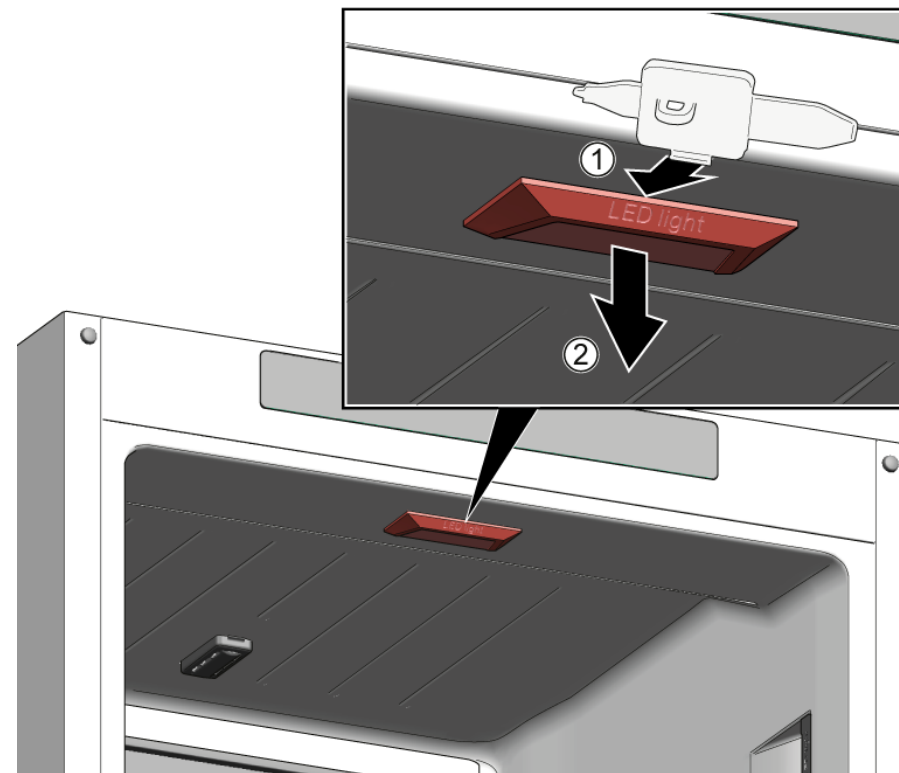

2. Atvienojiet augšējās LED spuldzes elektrisko savienojumu.
- ➡ Augšējā LED spuldze ir izņemta.

4.14.2 Augšējās LED spuldzes uzstādīšana

- ▶ Uzstādiet apgriezta kārtībā.

4.15 Sānu LED spuldzes nomaiņa

Speciāli rīki:

🔧 Īpašs darbarīks

[00342180]

i Ierīcē ir LED gaismeklis, kam nav jāveic apkope.
Šo gaismekli drīkst remontēt tikai klientu apkalpošanas dienesta pārstāvis vai pilnvarots tehniķis!

⚠ BĪSTAMI
Elektrotrieciena risks spriegumaktīvu daļu dēļ!
Dzīvības apdraudējums nepareiza remonta izraisīta elektrotrieciena dēļ

- ▶ Elektriskās daļas ir jāremontē kvalificētam elektriķim.
- ▶ Pēc remonta ierīces drošība ir jāpārbauda atbilstīgi noteikumiem VDE 0701 vai valsts noteikumiem.

⚠ BĪSTAMI
Elektrotrieciena risks, ko rada spriegumaktīvas detaļas!
Nāvējošs elektrotrieciens

- ▶ Atvienojiet iekārtas no strāvas padeves vismaz 60 sekundes pirms labošanas sākšanas.

⚠ ESIET PIESARDŽĪGI
Asas malas!
Griezta brūces

- ▶ Lietojiet aizsargcimdus.

⚠ UZMANĪBU!
Pret elektrostatisko izlādi jutīgu daļu (ESD) bojājuma risks!
Daļu bojājumi

- ▶ Lai darbotos ar ESD, izmantojiet elektrostatiskās drošības elementu (aprocī ar zemējumu).
- ▶ Nepieskarieties pie moduļu savienojumiem un vadojuma.
- ▶ Transportējiet ESD tikai vadītspējīgos materiālos vai oriģinālajā iepakojumā.
- ▶ Novērsiet, ka ESD tuvumā ir materiāli, kas var elektrostatiski uzlādēties (piemēram, plastmasa).

Prasība:

✓ Ierīcei ir jābūt atvienotai no strāvas padeves.

✓ Durvīm ir jābūt atvērtām.

✓ RC iekšējās daļas ir izņemtas.

4.15.1 Sānu LED spuldzes izņemšana

1. Iebīdīet demontāžas instrumentu starp spuldzes difuzoru un apvalku, lai atbrīvotu āķi (1).
2. Atvirziet spuldzes difuzoru (2).
3. Tāpat atbrīvojiet pārējos difuzora stiprinājuma āķus.

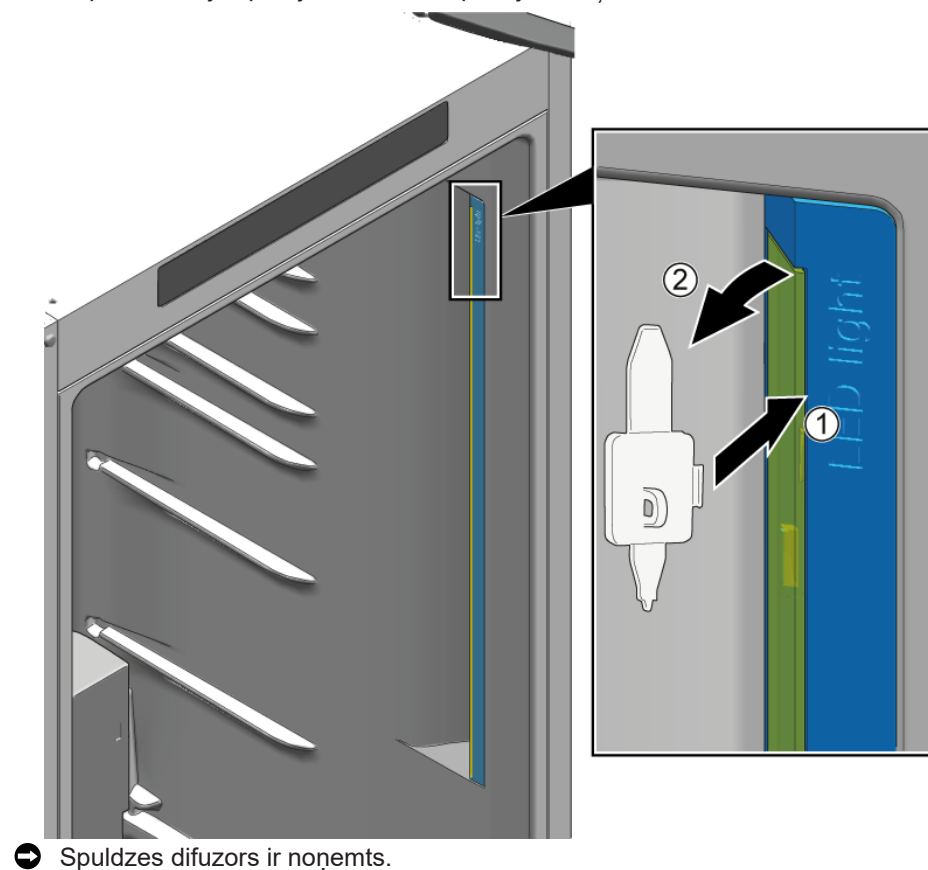

1. Lai atbrīvotu stiprinājuma āķi, uzspiediet uz tā (1).
2. Lai LED moduli atvienotu no elektriskās kontaktligzdas un noņemtu, pārvirziet to apm. 1 cm augšup (2).
3. Izņemiet LED moduli (3).

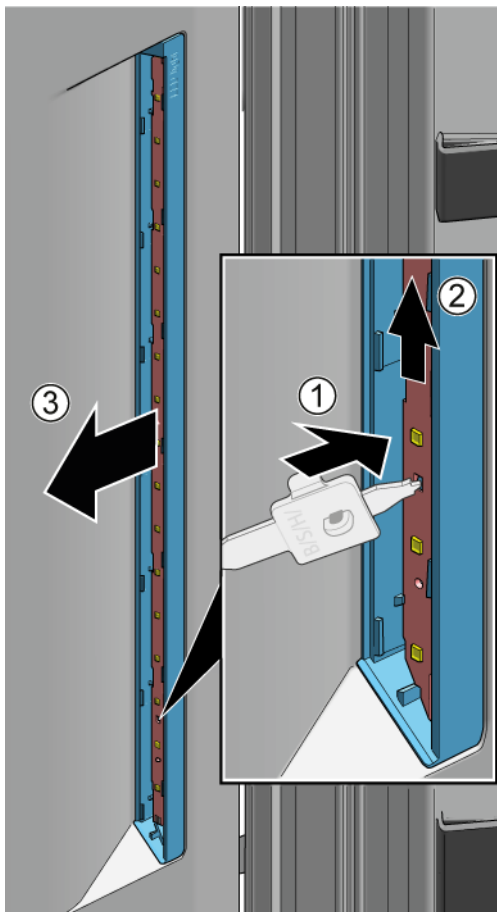

➔ Sānu LED spuldze ir izņemta.

4.15.2 Sānu LED spuldzes uzstādīšana



Izņemot spuldzes difuzoru, āķus var viegli salauzt, tāpēc sānu LED spuldze kā rezerves daļa ir komplekts, ko veido LED modulis un spuldzes difuzors.

1. Iebīdiet demontāžas instrumentu starp spuldzes difuzoru un apvalku, lai atbrīvotu āķi (1).
2. Atvirziet spuldzes difuzoru (2).
3. Tāpat atbrīvojiet pārējos difuzora stiprinājuma āķus.

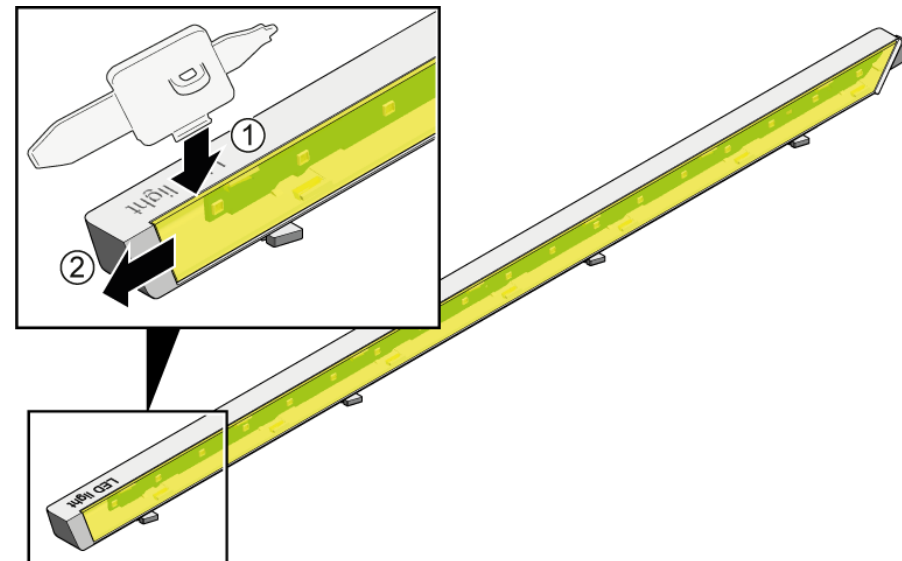

Remonts

1. Lai atbrīvotu stiprinājuma āķi, uzspiediet uz tā (1).
2. Izbīdiet LED moduli no apvalka augšup.
3. Utilizējiet LED moduļa apvalku, ko izmanto, lai droši transportētu rezerves daļas (3).

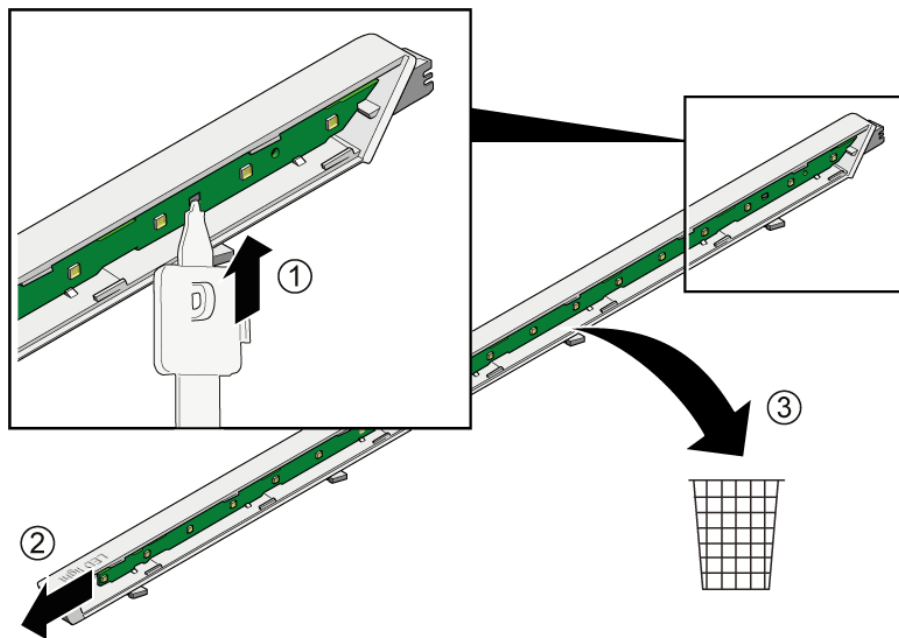

3. Uzstādiet LED moduli un spuldzes difuzoru, veicot noņemšanai pretējas darbības apgrieztā secībā.

4.16 Saldētavas LED spuldzes nomaīņa

Speciāli rīki:

🔧 Īpašs darbarīks

[00342180]

i Ierīcē ir LED gaismeklis, kam nav jāveic apkope.
Šo gaismekli drīkst remontēt tikai klientu apkalpošanas dienesta pārstāvis vai pilnvarots tehniķis!

⚠ BĪSTAMI
Elektrotrieciena risks spriegumaktīvu daļu dēļ!
Dzīvības apdraudējums nepareiza remonta izraisīta elektrotrieciena dēļ

- ▶ Elektriskās daļas ir jāremontē kvalificētam elektriķim.
- ▶ Pēc remonta ierīces drošība ir jāpārbauda atbilstīgi noteikumiem VDE 0701 vai valsts noteikumiem.

⚠ BĪSTAMI
Elektrotrieciena risks, ko rada spriegumaktīvas detaļas!
Nāvējošs elektrotrieciens

- ▶ Atvienojiet iekārtas no strāvas padeves vismaz 60 sekundes pirms labošanas sākšanas.

⚠ ESIET PIESARDZĪGI
Asas malas!
Griezta brūces

- ▶ Lietojiet aizsargcimdus.

Prasība:

- ✓ Ierīcei ir jābūt atvienotai no strāvas padeves.
- ✓ Durvīm ir jābūt atvērtām.

4.16.1 Saldētavas LED spuldzes izņemšana

- ▶ 1. Iebīdīet demontāžas instrumentu starp spuldzi un apvalku spuldzes pusē, lai izveidotu spraugu (1).
- ▶ 2. Bīdīet demontāžas instrumentu uz otru spuldzes pusi, kur atrodas spuldzes stiprinājuma āķis, un pagrieziet uz priekšu (2).
- ▶ 3. Izņemiet saldētavas LED spuldzi (3).

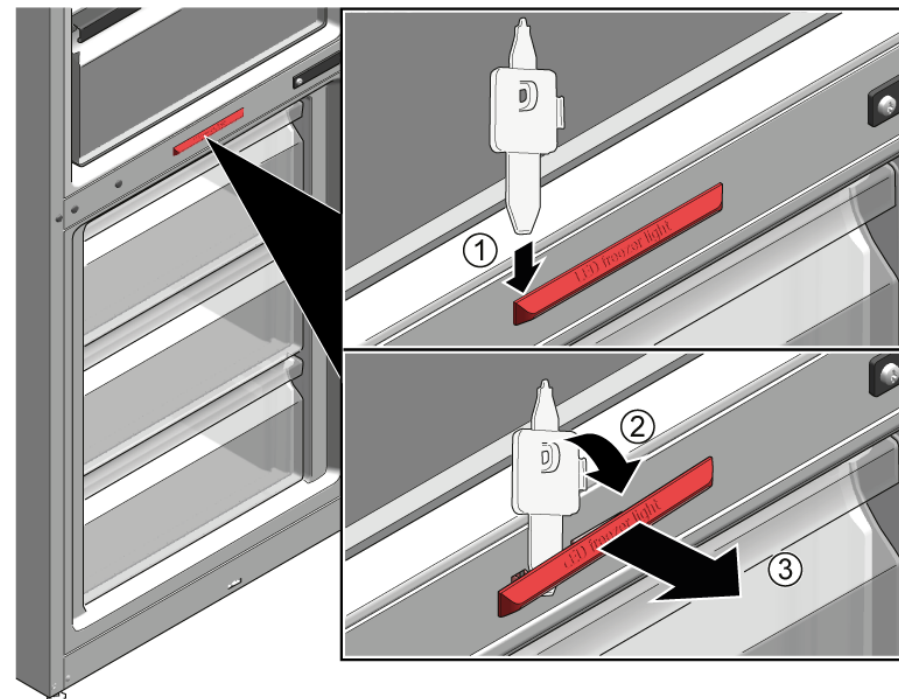





- ➡ Saldētavas LED spuldze ir atvienota.
- ➡ Saldētavas LED spuldze ir izņemta.

4.16.2 Saldētavas LED spuldzes uzstādīšana

- ▶ Uzstādiet apgrieztā kārtībā.

Informacija apie remontą - Šaldymo prietaiso ir šaldiklio kombinacija

 Dėl šio dokumento	419	4.8 Butelių padėklo keitimas.....	435
1.1 Svarbi informacija.....	419	4.8.1 Butelių padėklo išėmimas.....	435
1.1.1 Paskirtis.....	419	4.8.2 Butelių padėklo įdėjimas.....	435
1.2 Simbolių paaiškinimas.....	419	4.9 Durelių lentynos keitimas.....	436
1.2.1 Pavojaus lygiai.....	419	4.9.1 Durelių lentynos išėmimas.....	436
1.2.2 Pavojaus simboliai.....	419	4.9.2 Durelių lentynos įdėjimas.....	436
1.2.3 Įspėjimų struktūra.....	420	4.10 Saugojimo talpyklos pakeitimas.....	437
1.2.4 Bendrieji simboliai.....	420	4.10.1 Saugojimo talpyklos išėmimas.....	437
 Sauga	421	4.10.2 Saugojimo talpyklos įdėjimas.....	437
2.1 Bendrosios saugos instrukcijos.....	421	4.11 Vaisių ir daržovių talpyklos keitimas.....	438
2.1.1 Visi buitiniai prietaisai.....	421	4.11.1 Vaisių ir daržovių talpyklos išėmimas.....	438
 Įrankiai ir pagalbinės priemonės	422	4.11.2 Vaisių ir daržovių talpyklos įdėjimas.....	438
 Remontas	423	4.12 Lentynos virš vaisių ir daržovių talpyklos pakeitimas.....	439
4.1 Durelių tarpiklio keitimas.....	423	4.12.1 Lentynos virš vaisių ir daržovių lentynos išėmimas.....	439
4.1.1 Durelių tarpiklio išėmimas.....	423	4.12.2 Lentynos virš vaisių ir daržovių talpyklos įdėjimas.....	440
4.1.2 Durelių tarpiklio įdėjimas.....	423	4.13 Šaldytų maisto produktų talpyklos keitimas.....	441
4.2 Durelių rankenos keitimas.....	426	4.13.1 Šaldytų maisto produktų talpyklos išėmimas.....	441
4.2.1 Durelių rankenos nuėmimas.....	426	4.13.2 Šaldytų maisto produktų talpyklos įdėjimas.....	441
4.2.2 Durelių rankenos tvirtinimas.....	426	4.14 LED viršutinės lemputės pakeitimas.....	442
4.3 Durelių viršutinio vyro keitimas.....	427	4.14.1 LED viršutinės lemputės išėmimas.....	442
4.3.1 Viršutinio durelių vyro nuėmimas.....	427	4.14.2 LED viršutinės lemputės įmontavimas.....	442
4.3.2 Viršutinio durelių vyro uždėjimas.....	428	4.15 LED šoninės lemputės pakeitimas.....	443
4.4 Durelių viršutinio vyro keitimas (durelės su ekranu).....	429	4.15.1 LED šoninės lemputės išėmimas.....	443
4.4.1 Viršutinio durelių vyro nuėmimas.....	429	4.15.2 LED šoninės lemputės įmontavimas.....	444
4.4.2 Viršutinio durelių vyro uždėjimas.....	430	4.16 LED šaldiklio lemputės pakeitimas.....	446
4.5 Vidurinio durelių vyro keitimas.....	431	4.16.1 LED šaldiklio lemputės išėmimas.....	446
4.5.1 Vidurinio durelių vyro nuėmimas.....	431	4.16.2 LED šaldiklio lemputės įmontavimas.....	446
4.5.2 Vidurinių durelių vyro uždėjimas.....	432		
4.6 Apatinio durelių vyro keitimas.....	433		
4.6.1 Apatinio durelių vyro nuėmimas.....	433		
4.6.2 Apatinio durelių vyro uždėjimas.....	433		
4.7 Lentynos keitimas.....	434		
4.7.1 Lentynos nuėmimas.....	434		
4.7.2 Lentynos įdėjimas.....	434		

i Dėl šio dokumento

1.1 Svarbi informacija

1.1.1 Paskirtis

Šios remonto nuorodos padeda naudotojui pataisyti prietaisus patiems pagal galiojantį ekologinio projektavimo reglamentą (2021 m. kovo mėn. redakcija).

Jose pateikta informacija, kaip pakeisti tam tikras atsargines dalis, įskaitant ir įspėjimus bei riziką.

Jei kiltų klausimų, kreipkitės į mūsų klientų aptarnavimo tarnybą. Mes atsakysime už žalą tik tuo atveju, jei bus tinkamai laikomasi remonto nuorodų.

1.2 Simbolių paaiškinimas

1.2.1 Pavojaus lygiai

Įspėjimo lygiai susideda iš simbolio ir signalinio žodžio. Signalinis žodis nurodo pavojaus sunkumą.





Įspėjimo lygis	Reikšmė
 PAVOJUS	Nepaisant įspėjamojo pranešimo, ištinka mirtis arba sunkūs sužalojimai.
 ĮSPĖJIMAS	Nepaisant įspėjamojo pranešimo, gali ištikti mirtis arba sunkūs sužalojimai.
 PERSPĖJIMAS	Nepaisant įspėjamojo pranešimo, galimi nedideli sužalojimai.
DĖMESIO!	Nepaisant įspėjamojo pranešimo, gali būti sugadintas turtas.

Lentelė 1: Pavojaus lygiai



1.2.2 Pavojaus simboliai

Pavojaus simboliai yra simboliniai atvaizdai, nurodantys pavojaus rūšį.

Šiame: dokumente naudojami tokie pavojaus simboliai

Pavojaus simbolis	Reikšmė
	Bendras įspėjamasis pranešimas
	Pavojinga elektros įtampa
	Sprogimo pavojus
	Įpjovimo pavojus
	Prispaudimo pavojus

i Dėl šio dokumento

Pavojaus simbolis	Reikšmė
	Pavojus dėl karštų paviršių
	Pavojus dėl stipraus magnetinio lauko
	Pavojus dėl nejonizuojančiosios spinduliuotės

Lentelė 2: Pavojaus simboliai

1.2.3 Įspėjimų struktūra

Šiame dokumente pateikiami įspėjimai yra standartizuotos išvaizdos ir standartizuotos struktūros.



	<div style="background-color: red; color: white; padding: 2px; text-align: center;">⚠ PAVOJUS</div> <p>Pavojaus tipas ir šaltinis! Galimos pasekmės, jei nepaisoma pavojaus / įspėjimo.</p> <ul style="list-style-type: none"> ▶ Priemonės ir draudimai pavojui išvengti.
--	--





Šiame pavyzdyje parodytas įspėjimas, įspėjantis apie elektros smūgį dėl dalių su įtampa. Paminėta priemonė, kaip išvengti pavojaus.

	<div style="background-color: red; color: white; padding: 2px; text-align: center;">⚠ PAVOJUS</div> <p>Elektros smūgio pavojus dėl dalių, kuriose yra įtampa! Mirtis dėl elektros smūgio</p> <ul style="list-style-type: none"> ▶ Prieš pradėdami remontą, ne mažiau kaip prieš 60 sekundžių atjunkite prietaisus nuo elektros tiekimo.
---	--

1.2.4 Bendrieji simboliai

Šiame dokumente naudojami tokie bendrieji simboliai:

Bendr. simbolis	Reikšmė
	Žymi specialų patarimą (tekstas ir (arba) grafika)
	Žymi paprastą patarimą (tik tekstas)
	Žymi nuorodą į vaizdo pamoką

Bendr. simbolis	Reikšmė
	Žymi reikalingus įrankius
	Žymi reikalingas prielaidas
	Žymi sąlygą (jei ..., tai ...)
	Žymi rezultatą
[Paleisti]	Žymi klavišą arba ekrano mygtuką
[00123456]	Žymi dalies numerį
Būsena	Žymi rodomą tekstą / langą (prietaiso ekrane)

Lentelė 3: Bendrieji simboliai

2.1 Bendrosios saugos instrukcijos

2.1.1 Visi būtiniai prietaisai

Elektros smūgio pavojus dėl dalių, kuriose yra įtampa!

- Elektrinių konstrukcinių dalių remonto klaidos gali sukelti elektros smūgį!
- Prieš pradėdami dirbti, ne mažiau kaip prieš 60 sekundžių atjunkite prietaisą nuo maitinimo.
- Po remonto pasirūpinkite, kad būtų atliktas saugos bandymas pagal VDE 0701 arba šalyje galiojančius reglamentus.

Pavojus susižeisti į aštrias briaunas!

- Mūvėkite apsaugines pirštines.

Prispaudimo rizika remonto, einamosios techninės priežiūros, sutrikimų šalinimo ir techninės priežiūros metu dėl sunkių ir judančių konstrukcinių dalių

- Avėkite apsauginius batus.
- Apsaugokite sunkias konstrukcines dalis, kad jos nenukristų.
- Neartinkite kūno dalių prie judančių konstrukcinių dalių.

Rizika prietaiso saugai / veikimui!

- Naudokite tik originalias atsargines dalis.

Elektrostatškai jautrių konstrukcinių dalių (ESD) pažeidimo rizika!

- Nelieskite modulių, o taip pat ir jų jungčių bei laidininkų kelių.

Įrankiai ir pagalbinės priemonės

Paskyrimas	Išsami informacija	Vaizdai
„Torx“ antgalis TX20 [00340865]	6,3 mm (1/4 col.)	
Specialus įrankis [00342180]		

4.1 Durelių tarpiklio keitimas

Reikalavimas.

- ✔ Durelės turi būti atidarytos.

4.1.1 Durelių tarpiklio išėmimas

1. Išimkite durelių tarpiklį iš griovelio dešiniame ir kairiajame kampe.



2. Ištraukite durelių tarpiklį iš griovelio.



- ➡ Durelių tarpiklis išimtas.

4.1.2 Durelių tarpiklio įdėjimas





Naujo durelių tarpiklio storis gali šiek tiek skirtis nuo seno durelių tarpiklio storio. Dėl to durelės vis tiek užsidarys, o tarpiklį bus galima naudoti ilgai. Jei jūsų prietaiso vyriai arba vyro priedai reguliuojami, uždarymo funkciją vėliau galima optimizuoti. Nedidelės šoninės skylutės durelių tarpiklyje turi savo funkciją (reikalingos ventilacijai). Tai nėra gamybinis brokas.

1. Patikrinkite griovelį, ar nėra tarpiklių galinčių pažeisti vietų.

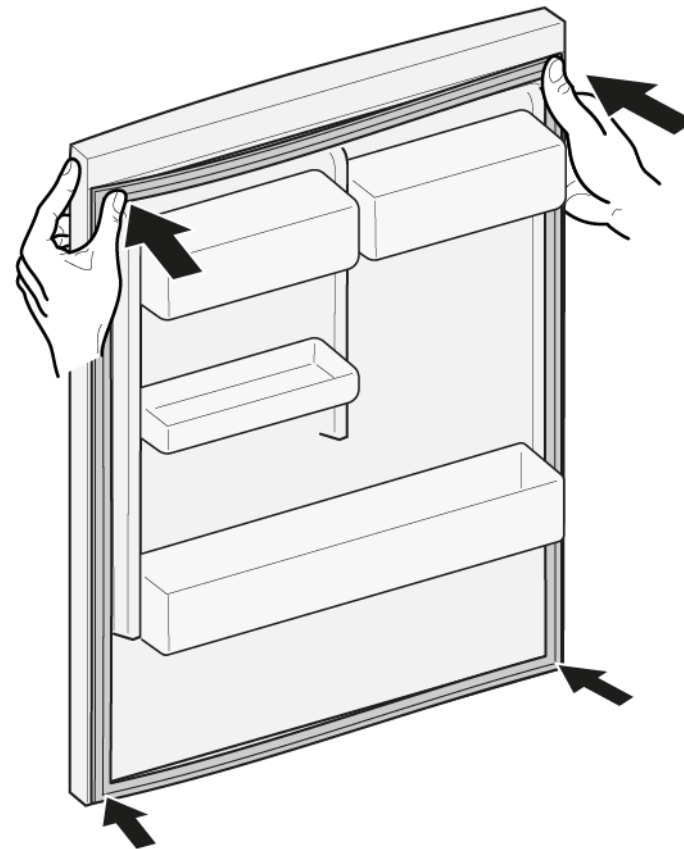

4. Įspauskite tarpiklio kampus viršuje ir apačioje į griovelį.



2.  Jei tarpiklio griovelis pažeistas.
- Kreipkitės į klientų aptarnavimo tarnybą.

3.  Nedidelės durelių tarpiklio deformacijos yra įprastas požymis ir nepaveikia tarpiklio funkcinių savybių. Prieš įdedant durelių tarpiklį į prietaisą, rekomenduojama jį ištiesinti.

Pašildykite durelių tarpiklių plaukų džiovintuvu arba karštu vandeniu ir iš naujo suteikite formą rankiniu būdu.

5. Po truputį įspauskite į griovelį visą tarpiklį.

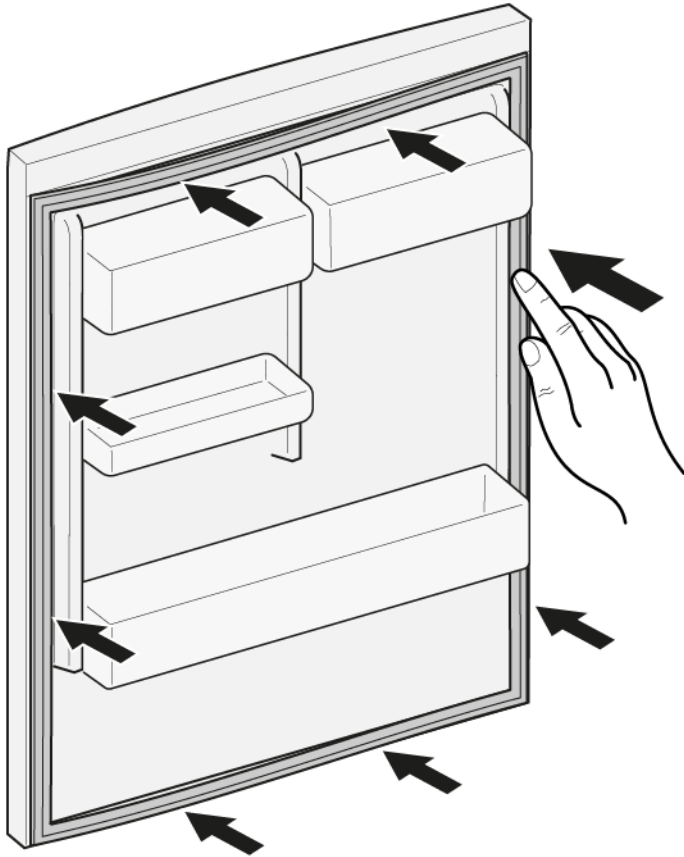

 Durelių tarpiklis įdėtas.

4.2 Durelių rankenos keitimas

Specialūs įrankiai.

- ☞ „Torx“ antgalis TX20 6,3 mm (1/4 col.) [00340865]
- ☞ Atsuktuvus su įpjovomis Mentė 10 mm x 1,6 mm x 200 mm

Reikalavimas.

- ✔ Prietaisas turi būti atjungtas nuo maitinimo šaltinio.
- ✔ Durelės turi būti atidarytos.

4.2.1 Durelių rankenos nuėmimas

- ▶ 1. Išimkite du varžtų gaubtelius (1).
- ▶ 2. Išsukite du varžtus (2).
- ▶ 3. Nuimkite durelių rankeną (3).

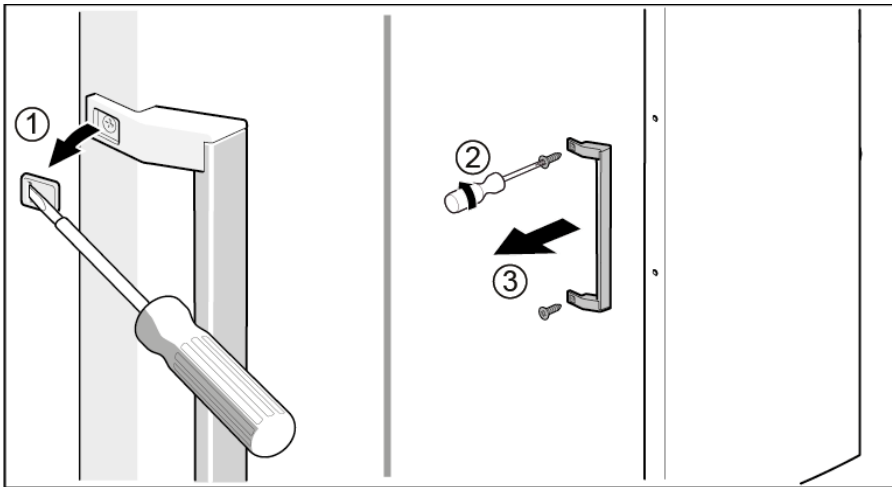

➔ Durelių rankena nuimta.



Antrą durelių rankenėlę galima nuimti tokiu pačiu būdu.

4.2.2 Durelių rankenos tvirtinimas

- ▶ Uždėkite atvirkščia eilės tvarka.

4.3 Durelių viršutinio vyro keitimas

Specialūs įrankiai.

„Torx“ antgalis TX20

6,3 mm (1/4 col.)

[00340865]

	<p>ĮSPĖJIMAS</p> <p>Sunkūs ir dideli prietaisai! Nugaros ir raumenų sužalojimai</p> <ul style="list-style-type: none"> ▶ Prietaiso dureles nuimti gali tik apmokyti specialistai. ▶ Norint perkelti prietaisą į kitą vietą, reikalingi du žmonės. ▶ Naudokite tik tinkamus įrankius ir įrangą.
	<p>PERSPĖJIMAS</p> <p>Aštrios briaunos! Galima įsipjauti</p> <ul style="list-style-type: none"> ▶ Mūvėkite apsaugines pirštines.
	<p>ĮSPĖJIMAS</p> <p>Paverstų prietaisų slydimas! Galimi kaulų lūžiai ir prispaudimai</p> <ul style="list-style-type: none"> ▶ Apsaugokite prietaisus, kad jie nepaslystų.
	<p>PERSPĖJIMAS</p> <p>Pavojus, kad atpalaidavus varžtus dalys nukris! Krentančios dalys gali sužeisti.</p> <ul style="list-style-type: none"> ▶ Apsaugokite konstrukcinę dalį, kad ji nenukristų.
	<p>DĖMESIO!</p> <p>Pavojus, kad atpalaidavus varžtus dalys nukris! Gali būti sugadintos kitos prietaiso dalys arba kliento namai, pvz., grindys.</p> <ul style="list-style-type: none"> ▶ Apsaugokite konstrukcinę dalį, kad ji nenukristų.

Reikalavimas.

- ✔ Prietaisas turi būti atjungtas nuo maitinimo šaltinio.
- ✔ Prietaiso vidiniai tvirtinimo elementai turi būti nuimti.

4.3.1 Viršutinio durelių vyro nuėmimas

1. Pastumkite atraminę dalį po pagrindo skyriumi.

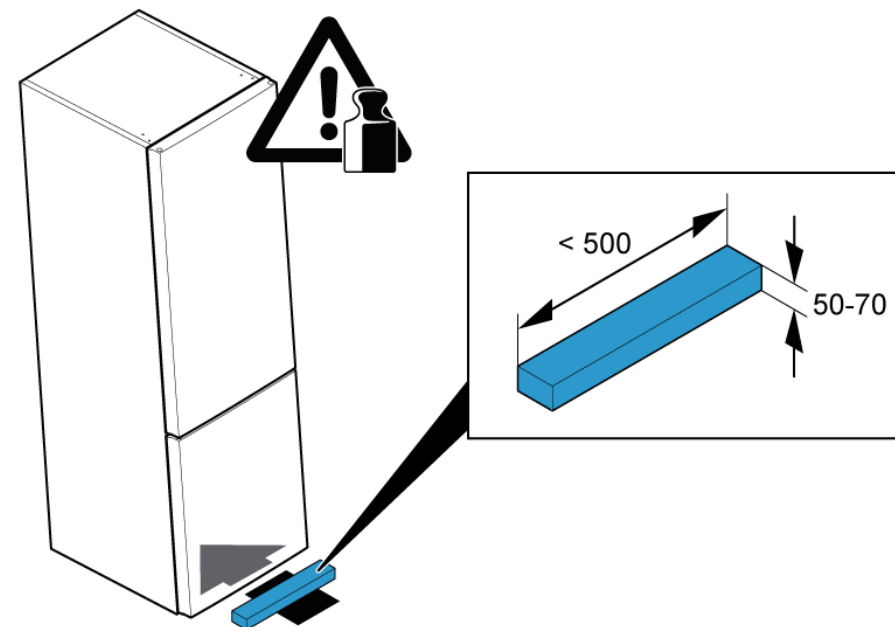

2. 1. Nuimkite viršutinio vyro uždangą (1).
2. Išsukite du varžtus (2).
3. Nuimkite viršutinį vyrį (3).

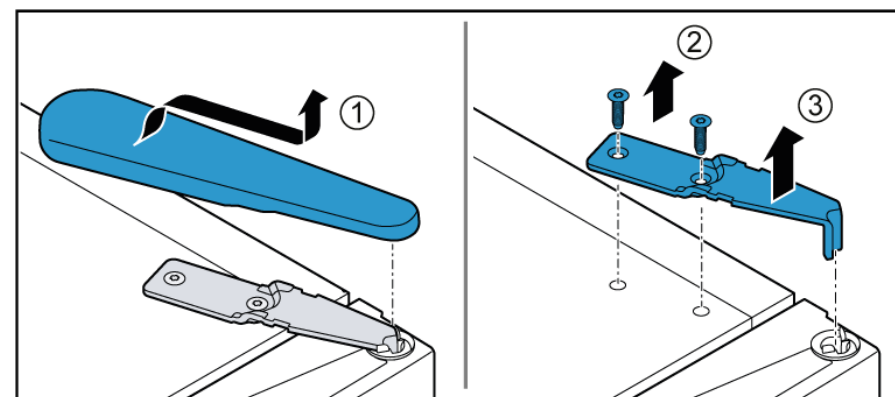

3. Nuimkite viršutines dureles.

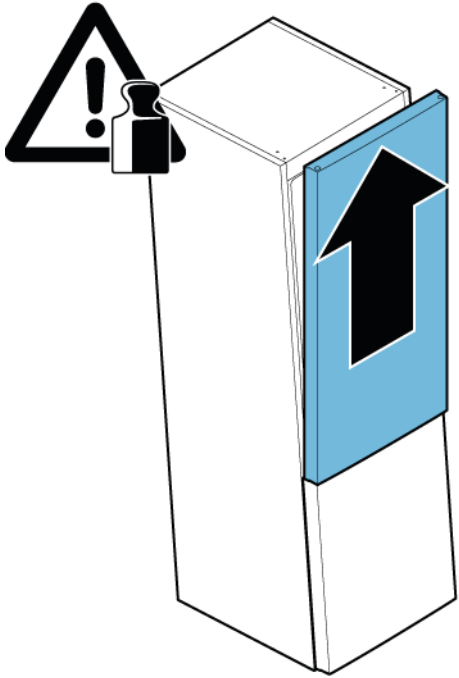

➔ Viršutinis vysis išimtas.

4.3.2 Viršutinio durelių vryio uždėjimas

- ▶ Uždėkite atvirkščia eilės tvarka.

4.4 Durelių viršutinio vyro keitimas (durelės su ekranu)

Specialūs įrankiai.

„Torx“ antgalis TX20

6,3 mm (1/4 col.)

[00340865]

	<p style="text-align: center;">⚠️ ĮSPĖJIMAS</p> <p>Sunkūs ir dideli prietaisai! Nugaros ir raumenų sužalojimai</p> <ul style="list-style-type: none"> ▶ Prietaiso dureles nuimti gali tik apmokyti specialistai. ▶ Norint perkelti prietaisą į kitą vietą, reikalingi du žmonės. ▶ Naudokite tik tinkamus įrankius ir įrangą.
	<p style="text-align: center;">⚠️ PERSPĖJIMAS</p> <p>Aštrios briaunos! Galima įsipjauti</p> <ul style="list-style-type: none"> ▶ Mūvėkite apsaugines pirštines.
	<p style="text-align: center;">⚠️ ĮSPĖJIMAS</p> <p>Paverstų prietaisų slydimas! Galimi kaulų lūžiai ir prispaudimai</p> <ul style="list-style-type: none"> ▶ Apsaugokite prietaisus, kad jie nepaslystų.
	<p style="text-align: center;">⚠️ PERSPĖJIMAS</p> <p>Pavojus, kad atpalaidavus varžtus dalys nukris! Krentančios dalys gali sužeisti.</p> <ul style="list-style-type: none"> ▶ Apsaugokite konstrukcinę dalį, kad ji nenukristų.
	<p style="text-align: center;">⚠️ DĖMESIO!</p> <p>Pavojus, kad atpalaidavus varžtus dalys nukris! Gali būti sugadintos kitos prietaiso dalys arba kliento namai, pvz., grindys.</p> <ul style="list-style-type: none"> ▶ Apsaugokite konstrukcinę dalį, kad ji nenukristų.

	<p style="text-align: center;">⚠️ PAVOJUS</p> <p>Elektros smūgio pavojus dėl dalių, kuriose yra įtampa! Pavojus gyvybei dėl elektros smūgio netinkamo remonto atveju</p> <ul style="list-style-type: none"> ▶ Elektrines dalis remontuoti turi kvalifikuoti elektrikai. ▶ Po remonto pasirūpinkite, kad būtų atliktas saugos bandymas pagal VDE 0701 arba šalyje galiojančius reglamentus.
---	--

	<p style="text-align: center;">⚠️ PAVOJUS</p> <p>Elektros smūgio pavojus dėl dalių, kuriose yra įtampa! Mirtis dėl elektros smūgio</p> <ul style="list-style-type: none"> ▶ Prieš pradėdami remontą, ne mažiau kaip prieš 60 sekundžių atjunkite prietaisus nuo elektros tiekimo.
---	--

Reikalavimas.

- ✓ Prietaisas turi būti atjungtas nuo maitinimo šaltinio.
- ✓ Prietaiso vidiniai tvirtinimo elementai turi būti nuimti.

4.4.1 Viršutinio durelių vyro nuėmimas

1. Pastumkite atraminę dalį po pagrindo skyriumi.

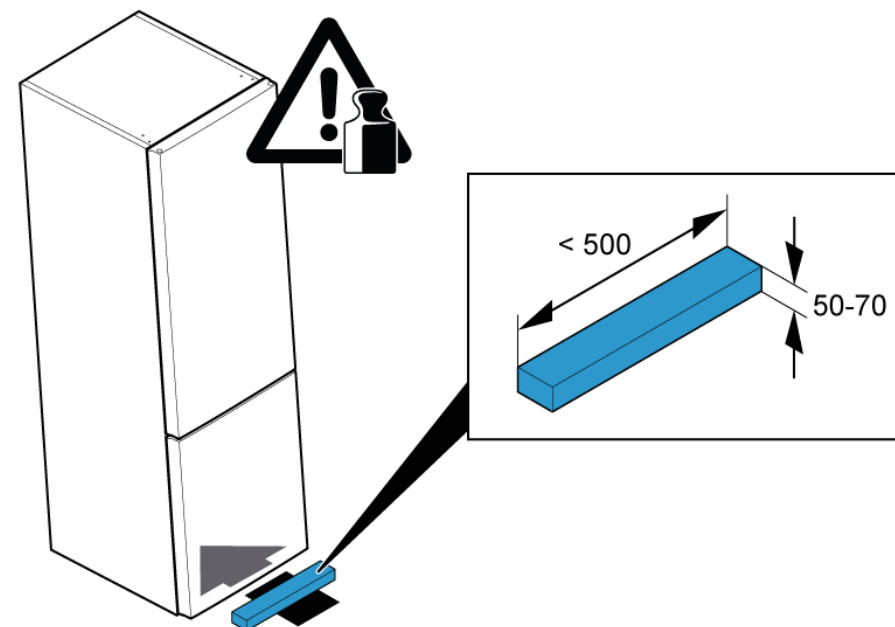

Remontas

2. 1. Nuimkite viršutinio vyro uždangą (1).
2. Atjunkite elektros jungtį (2).
3. Atsukite įžeminimo jungties varžtą (3).

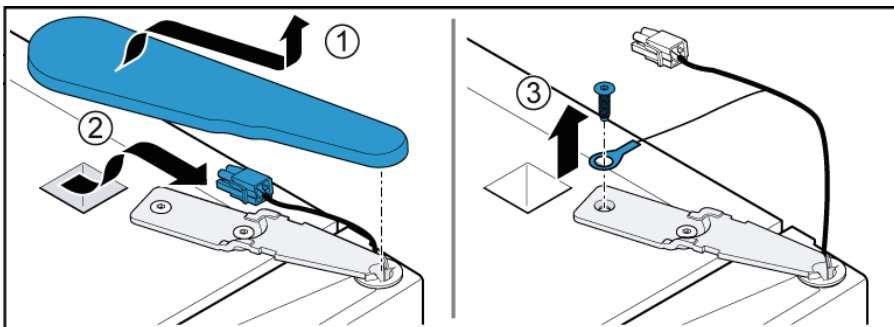

3. 1. Išsukite varžtą (1).
2. Nuimkite viršutinį vyrį (2).

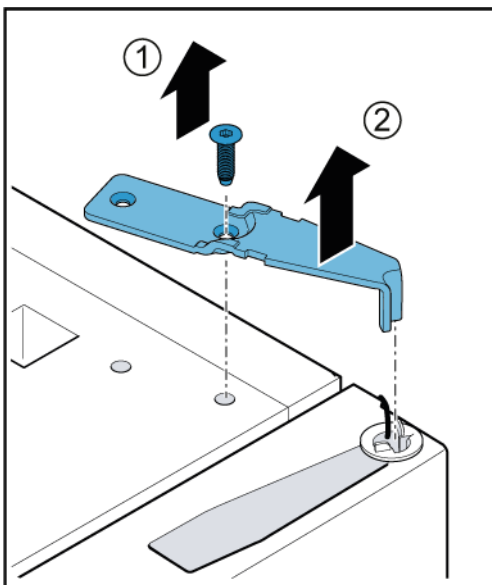

4. Nuimkite viršutines dureles.

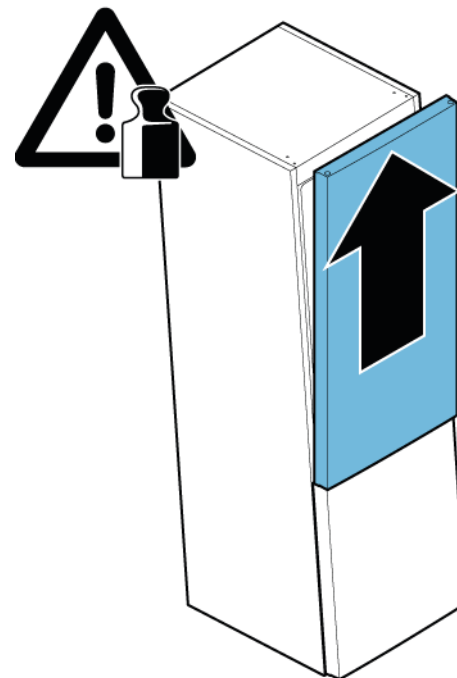

➔ Viršutinis vyris išimtas.

4.4.2 Viršutinio durelių vyro uždėjimas

- ▶ Uždėkite atvirkščia eilės tvarka.





4.5 Vidurinio durelių vyrio keitimas

Specialūs įrankiai.

„Torx“ antgalis TX20

6,3 mm (1/4 col.)

[00340865]

	<p>ĮSPĖJIMAS</p> <p>Sunkūs ir dideli prietaisai! Nugaros ir raumenų sužalojimai</p> <ul style="list-style-type: none"> ▶ Prietaiso dureles nuimti gali tik apmokyti specialistai. ▶ Norint perkelti prietaisą į kitą vietą, reikalingi du žmonės. ▶ Naudokite tik tinkamus įrankius ir įrangą.
	<p>PERSPĖJIMAS</p> <p>Aštrios briaunos! Galima įsipjauti</p> <ul style="list-style-type: none"> ▶ Mūvėkite apsaugines pirštines.
	<p>ĮSPĖJIMAS</p> <p>Paverstų prietaisų slydimas! Galimi kaulų lūžiai ir prispaudimai</p> <ul style="list-style-type: none"> ▶ Apsaugokite prietaisus, kad jie nepaslystų.
	<p>PERSPĖJIMAS</p> <p>Pavojus, kad atpalaidavus varžtus dalys nukris! Krentančios dalys gali sužeisti.</p> <ul style="list-style-type: none"> ▶ Apsaugokite konstrukcinę dalį, kad ji nenukristų.
	<p>DĖMESIO!</p> <p>Pavojus, kad atpalaidavus varžtus dalys nukris! Gali būti sugadintos kitos prietaiso dalys arba kliento namai, pvz., grindys.</p> <ul style="list-style-type: none"> ▶ Apsaugokite konstrukcinę dalį, kad ji nenukristų.

Reikalavimas.

- ✔ Prietaisas turi būti atjungtas nuo maitinimo šaltinio.
- ✔ Prietaiso vidiniai tvirtinimo elementai nuimti.
- ✔ Durelių viršutinis vyris išimtas.
- ✔ Viršutinės durelės nuimtos.

4.5.1 Vidurinio durelių vyrio nuėmimas

1. Išsukite du varžtus (1).
2. Nuimkite vidurinį vyrį (2).

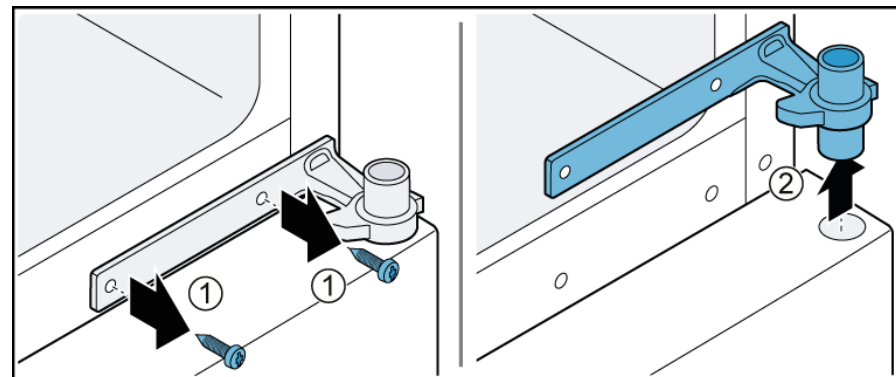

2. Nuimkite apatines dureles.

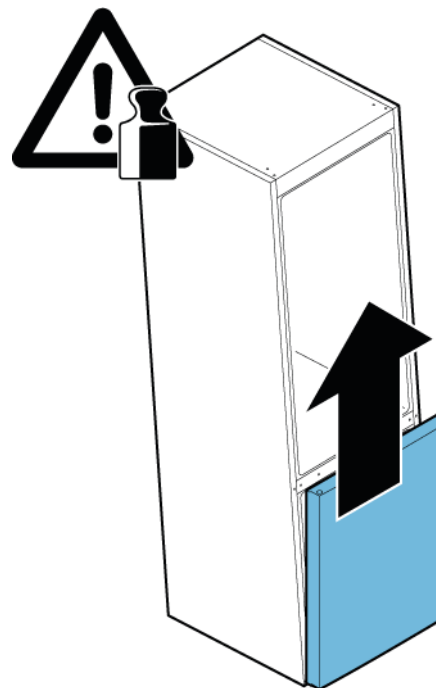

- ➡ Vidurinis vyris nuimtas.

4.5.2 Vidurinių durelių vyro uždėjimas

- ▶ Uždėkite atvirkščia eilės tvarka.





4.6 Apatinio durelių vyro keitimas

Specialūs įrankiai.

„Torx“ antgalis TX20

6,3 mm (1/4 col.)

[00340865]

	<p style="text-align: center;">⚠️ ĮSPĖJIMAS</p> <p>Sunkūs ir dideli prietaisai! Nugaros ir raumenų sužalojimai</p> <ul style="list-style-type: none"> ▶ Prietaiso dureles nuimti gali tik apmokyti specialistai. ▶ Norint perkelti prietaisą į kitą vietą, reikalingi du žmonės. ▶ Naudokite tik tinkamus įrankius ir įrangą.
	<p style="text-align: center;">⚠️ PERSPĖJIMAS</p> <p>Aštrios briaunos! Galima įsipjauti</p> <ul style="list-style-type: none"> ▶ Mūvėkite apsaugines pirštines.
	<p style="text-align: center;">⚠️ ĮSPĖJIMAS</p> <p>Paverstų prietaisų slydimas! Galimi kaulų lūžiai ir prispaudimai</p> <ul style="list-style-type: none"> ▶ Apsaugokite prietaisus, kad jie nepaslystų.
	<p style="text-align: center;">⚠️ PERSPĖJIMAS</p> <p>Pavojus, kad atpalaidavus varžtus dalys nukris! Krentančios dalys gali sužeisti.</p> <ul style="list-style-type: none"> ▶ Apsaugokite konstrukcinę dalį, kad ji nenukristų.
	<p style="text-align: center;">DĖMESIO!</p> <p>Pavojus, kad atpalaidavus varžtus dalys nukris! Gali būti sugadintos kitos prietaiso dalys arba kliento namai, pvz., grindys.</p> <ul style="list-style-type: none"> ▶ Apsaugokite konstrukcinę dalį, kad ji nenukristų.

Reikalavimas.

- ✔️ Prietaisas turi būti atjungtas nuo maitinimo šaltinio.
- ✔️ Prietaiso vidiniai tvirtinimo elementai turi būti nuimti.
- ✔️ Viršutinis vyris nuimtas.
- ✔️ Vidurinis vyris nuimtas.

4.6.1 Apatinio durelių vyro nuėmimas

- ▶ 1. Išsukite du varžtus (1).
- ▶ 2. Nuimkite apatinį vyrį (2).

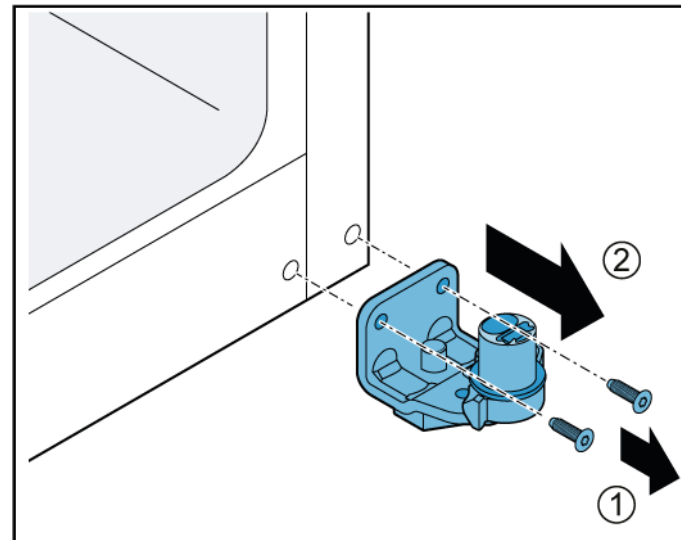

- ➡️ Apatinis durelių vyris nuimtas.

4.6.2 Apatinio durelių vyro uždėjimas

- ▶ Uždėkite atvirkščia eilės tvarka.

4.7 Lentynos keitimas

Reikalavimas.

- ✔ Durelės turi būti atidarytos.

4.7.1 Lentynos nuėmimas

- ▶ 1. Pakelkite lentynos užpakalinę dalį (1).
- ▶ 2. Atlaisvinkite lentyną (2).

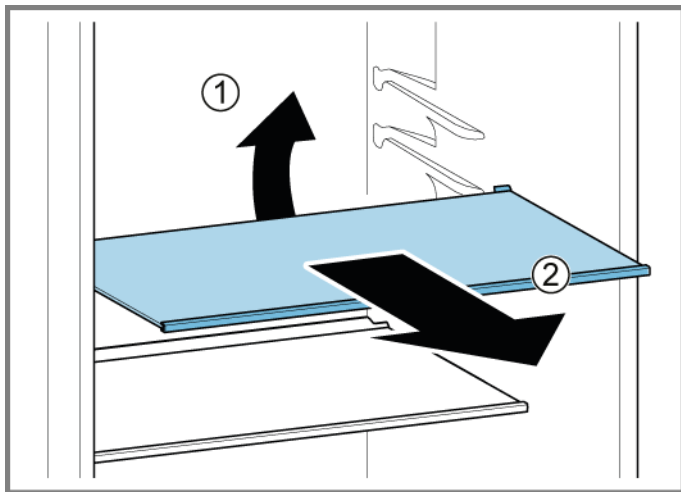

➡ Lentyna yra išimta.

4.7.2 Lentynos įdėjimas

- ▶ Uždėkite atvirkščia eilės tvarka.

4.8 Butelių padėklo keitimas

Reikalavimas.

- ✔ Durelės turi būti atidarytos.

4.8.1 Butelių padėklo išėmimas

- ▶ Ištraukite butelių padėklą.

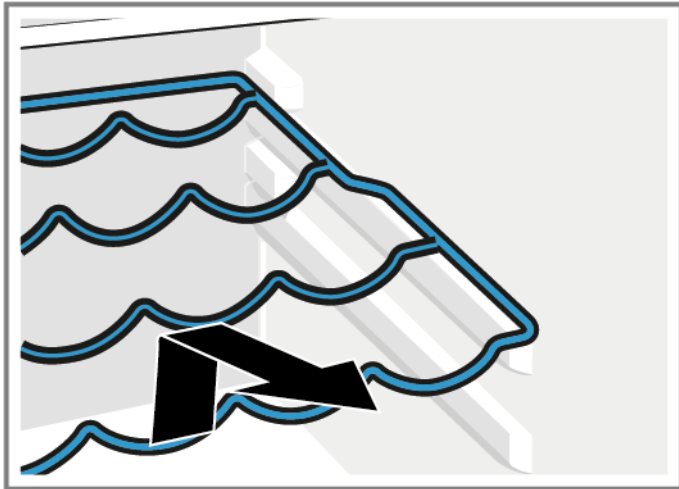

- ➔ Butelių padėklas išimtas.

4.8.2 Butelių padėklo įdėjimas

- ▶ Uždėkite atvirkščia eilės tvarka.

4.9 Durelių lentynos keitimas

Reikalavimas.

- ✔ Durelės turi būti atidarytos.

4.9.1 Durelių lentynos išėmimas

- ▶ Pakelkite durelių lentyną į viršų.

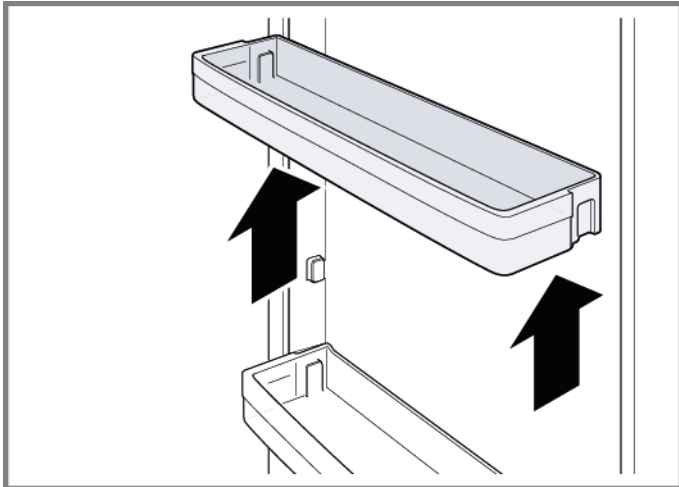

- ➡ Durelių lentyna išimta.

4.9.2 Durelių lentynos įdėjimas

- ▶ Uždėkite atvirkščia eilės tvarka.

4.10 Saugojimo talpyklos pakeitimas

Reikalavimas.

- ✔ Durelės turi būti atidarytos.

4.10.1 Saugojimo talpyklos išėmimas

1. Ištraukite saugojimo talpyklą, tiek, kiek galima.
2. 1. Pakelkite saugojimo talpyklos priekį (1).
2. Išimkite talpyklą (2).

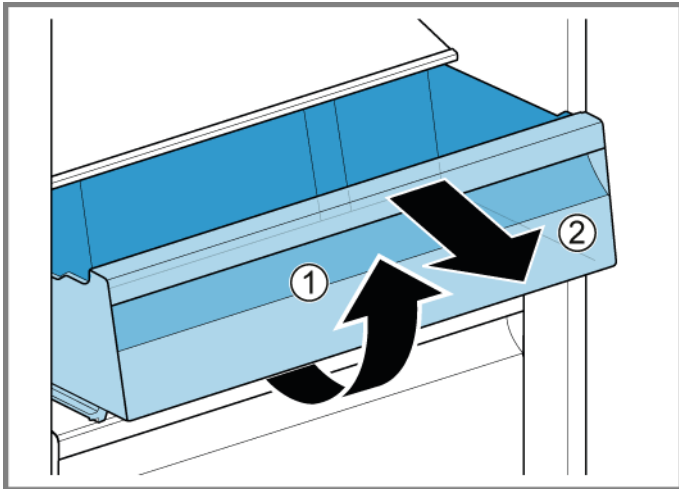

- ➔ Saugojimo talpykla yra išimta.

4.10.2 Saugojimo talpyklos įdėjimas

- ▶ Uždėkite atvirkščia eilės tvarka.

4.11 Vaisių ir daržovių talpyklos keitimas

Reikalavimas.

- ✔ Durelės turi būti atidarytos.

4.11.1 Vaisių ir daržovių talpyklos išėmimas

1. Ištraukite vaisių ir daržovių talpyklą, tiek, kiek galima.
2. 1. Pakelkite vaisių ir daržovių talpyklos priekį (1).
2. Išimkite talpyklą (2).

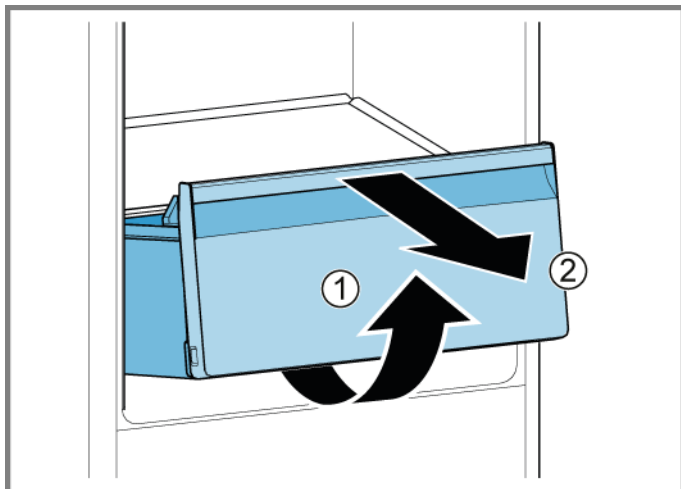

- ➡ Vaisių ir daržovių talpykla išimta.

4.11.2 Vaisių ir daržovių talpyklos įdėjimas

- ▶ Uždėkite atvirkščia eilės tvarka.

4.12 Lentynos virš vaisių ir daržovių talpyklos pakeitimas

Reikalavimas.

- ✔ Durelės turi būti atidarytos.
- ✔ [Vaisių ir daržovių talpykla išimta.→438](#)

4.12.1 Lentynos virš vaisių ir daržovių lentynos išėmimas

1. Pastumkite sandarinimo rėmą į viršų ir išstumkite iš jo vietas.

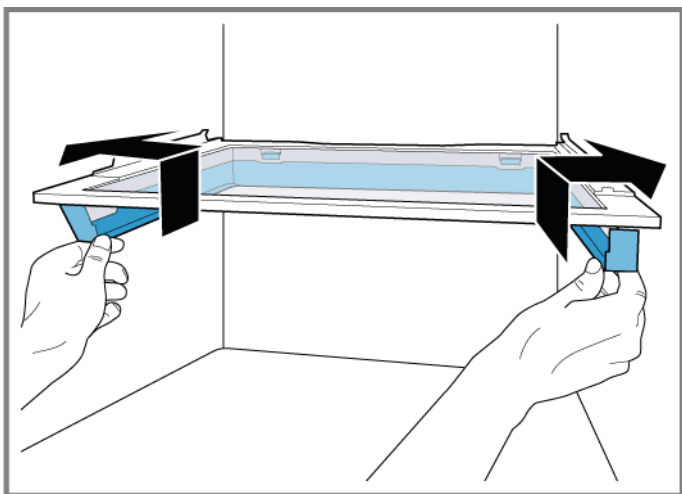

- ➡ Šoniniai kabliukai yra atlaisvinti.

2. Pakelkite sandarinimo rėmą ir įstumkite jį atgal.

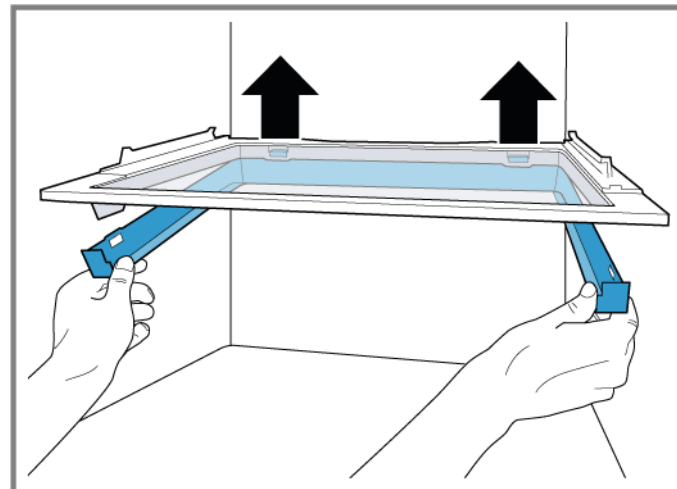

- ➡ Galiniai kabliukai yra atlaisvinti.

3. Išimkite sandarinimo rėmą.
4. Pakelkite lentyną virš vaisių ir daržovių talpyklos ir pakreipkite ją šonu.

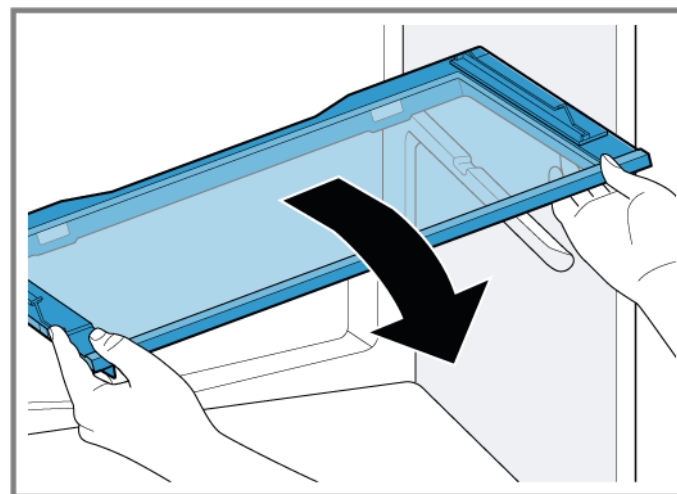

- ➡ Lentyna virš vaisių ir daržovių talpyklos yra išimta.

4.12.2 Lentynos virš vaisių ir daržovių talpyklos įdėjimas

- ▶ Uždėkite atvirkščia eilės tvarka.

4.13 Šaldytų maisto produktų talpyklos keitimas

Reikalavimas.

- ✔ Durelės turi būti atidarytos.

4.13.1 Šaldytų maisto produktų talpyklos išėmimas

- ▶ 1. Ištraukite šaldytų maisto produktų talpyklą iki pat galo (1).
- ▶ 2. Išimkite maisto produktų talpyklą (2).

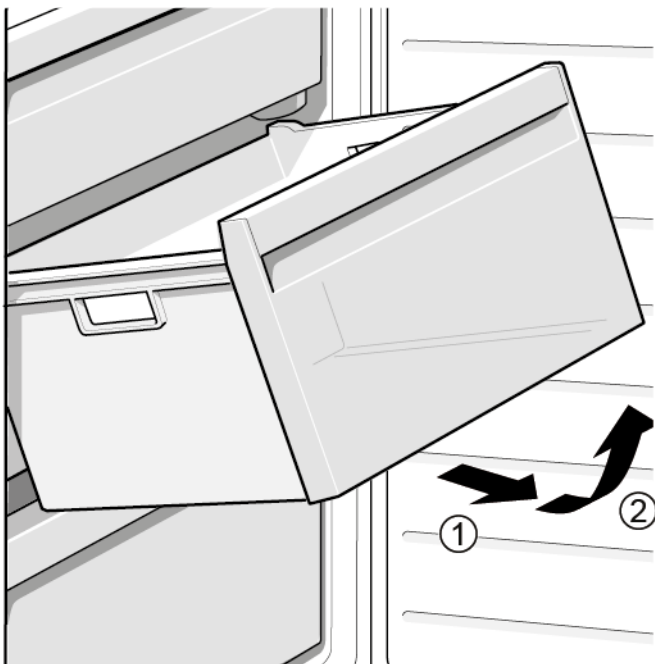

- ➡ Šaldytų maisto produktų talpykla išimta.

4.13.2 Šaldytų maisto produktų talpyklos įdėjimas

- ▶ Uždėkite atvirksčia eilės tvarka.

4.14 LED viršutinės lemputės pakeitimas

Specialūs įrankiai.

Specialus įrankis

[00342180]



Jūsų prietaise yra techninės priežiūros nereikalaujanti LED lemputė. Šias lemputes gali pataisyti tik klientų aptarnavimo tarnybos specialistai arba įgalioti technikai!



PAVOJUS

Elektros smūgio pavojus dėl dalių, kuriose yra įtampa!

Pavojus gyvybei dėl elektros smūgio netinkamo remonto atveju

- ▶ Elektrines dalis remontuoti turi kvalifikuoti elektrikai.
- ▶ Po remonto pasirūpinkite, kad būtų atliktas saugos bandymas pagal VDE 0701 arba šalyje galiojančius reglamentus.



PAVOJUS

Elektros smūgio pavojus dėl dalių, kuriose yra įtampa!

Mirtis dėl elektros smūgio

- ▶ Prieš pradėdami remontą, ne mažiau kaip prieš 60 sekundžių atjunkite prietaisus nuo elektros tiekimo.



PERSPĖJIMAS

Aštrios briaunos!

Galima įsipjauti

- ▶ Mūvėkite apsaugines pirštines.

Reikalavimas.

- ✓ Prietaisas atjungtas nuo maitinimo šaltinio.
- ✓ Durelės turi būti atidarytos.

4.14.1 LED viršutinės lemputės išėmimas

1. Norėdami atlaisvinti lemputės kablukus (1) stumkite išardymo įrankį tarp LED viršutinės lemputės ir šaldytuvo skyriaus vidinės apdailos.
2. Nuimkite LED viršutinę lemputę (2).

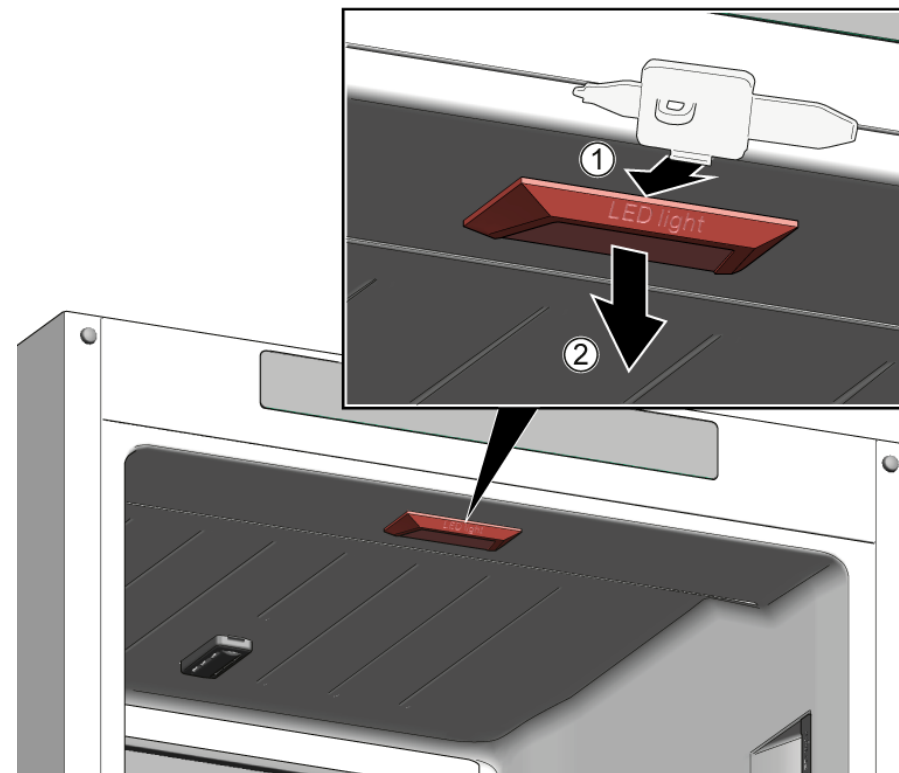

2. Atjunkite LED viršutinės lemputės elektros jungtį.
- ➡ LED viršutinė lemputė yra išimta.

4.14.2 LED viršutinės lemputės įmontavimas

- ▶ Uždėkite atvirkščia eilės tvarka.

4.15 LED šoninės lemputės pakeitimas

Specialūs įrankiai.

Specialus įrankis

[00342180]

i Jūsų prietaise yra techninės priežiūros nereikalaujanti LED lemputė. Šias lemputes gali pataisyti tik klientų aptarnavimo tarnybos specialistai arba įgalioti technikai!

PAVOJUS
Elektros smūgio pavojus dėl dalių, kuriose yra įtampa!
 Pavojus gyvybei dėl elektros smūgio netinkamo remonto atveju

- ▶ Elektrines dalis remontuoti turi kvalifikuoti elektrikai.
- ▶ Po remonto pasirūpinkite, kad būtų atliktas saugos bandymas pagal VDE 0701 arba šalyje galiojančius reglamentus.

PAVOJUS
Elektros smūgio pavojus dėl dalių, kuriose yra įtampa!
 Mirtis dėl elektros smūgio

- ▶ Prieš pradėdami remontą, ne mažiau kaip prieš 60 sekundžių atjunkite prietaisus nuo elektros tiekimo.

PERSPĖJIMAS
Aštrios briaunos!
 Galima įsipjauti

- ▶ Mūvėkite apsaugines pirštines.

DĖMESIO!
Elektrostatškai jautrių konstrukcinių dalių (ESD) pažeidimo rizika!
 Konstrukcinių dalių pažeidimas

- ▶ Prieš liėsdami ESD dalis užsidėkite elektrostatinės apsaugos sistemą (apyrankę su įžeminimo kištuku).
- ▶ Nelieskite modulių jungčių bei laidininkų kelių.
- ▶ ESD dalis transportuokite tik laidžiose medžiagose arba originalioje pakuotėje.
- ▶ Neartinkite ESD dalių prie elektrostatškai įsikraunančių medžiagų (pvz., plastikų).

Reikalavimas.

✓ Prietaisas atjungtas nuo maitinimo šaltinio.

✓ Durelės turi būti atidarytos.

✓ RC vidiniai tvirtinimo elementai yra išimti.

4.15.1 LED šoninės lemputės išėmimas

1. Kad atkabintumėte kabliuką, įstumkite išardymo įrankį tarp lemputės difuzoriaus ir korpuso (1).
2. Išimkite lemputę iš difuzoriaus (2).
3. Tokiu pat būdu atlaisvinkite ir kitus difuzorius fiksavimo kabliukus.

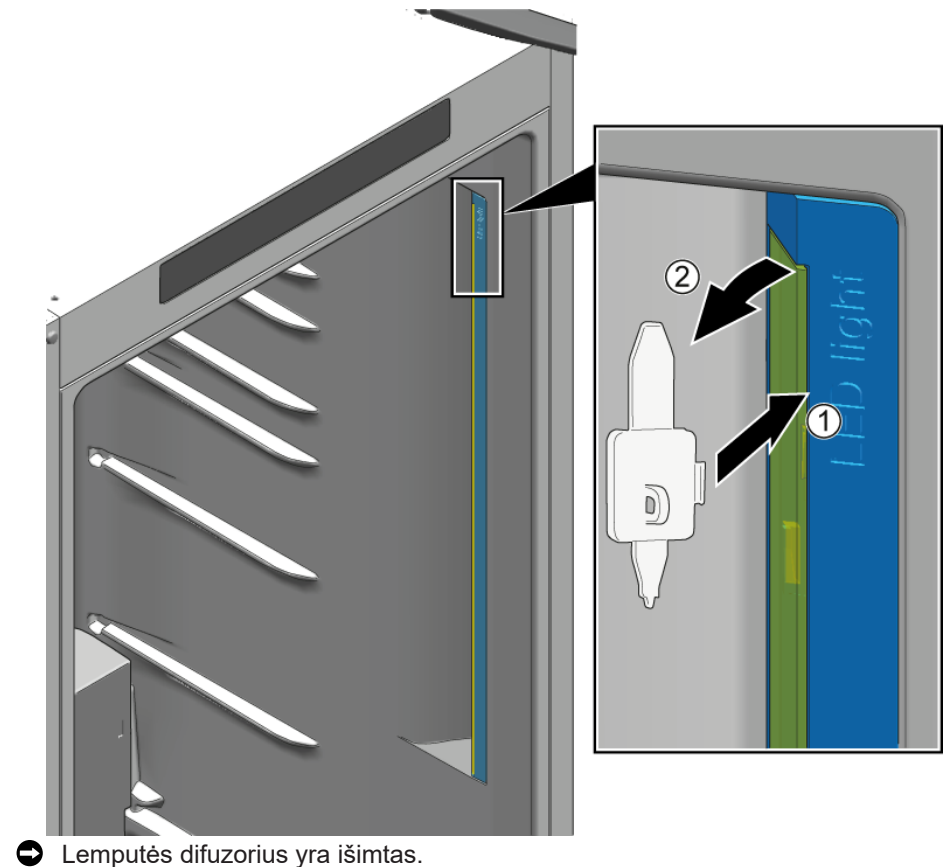

1. Atpalaiduokite fiksavimo kabliuką, jį spustelėdami (1).
2. Norėdami ištraukti LED modulį iš elektros lizdo ir nuo jo atjungti, LED modulį perkelkite maždaug 1 cm aukšty (2).
3. Nuimkite LED modulį (3).

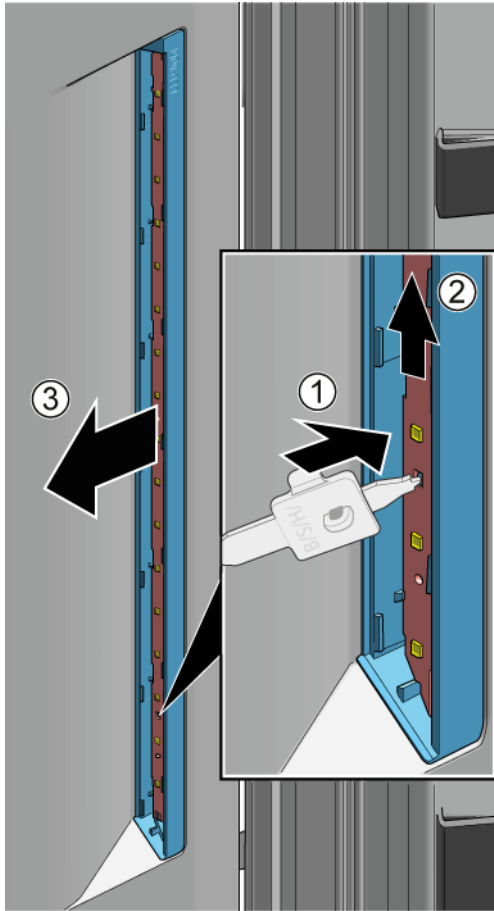

 LED šoninė lemputė yra išimta.

4.15.2 LED šoninės lemputės įmontavimas



Kadangi nuimant lempos difuzoriaus kabliukus lengva sulaužyti, atsarginė LED šoninės lemputės atsarginė dalis yra komplektas, kurį sudaro LED modulis ir lemputės difuzorius.

1. Kad atkabintumėte kabliuką, įstumkite išardymo įrankį tarp lemputės difuzoriaus ir korpuso (1).
2. Išimkite lemputę iš difuzoriaus (2).
3. Tokiu pat būdu atlaisvinkite ir kitus difuzoriaus fiksavimo kabliukus.

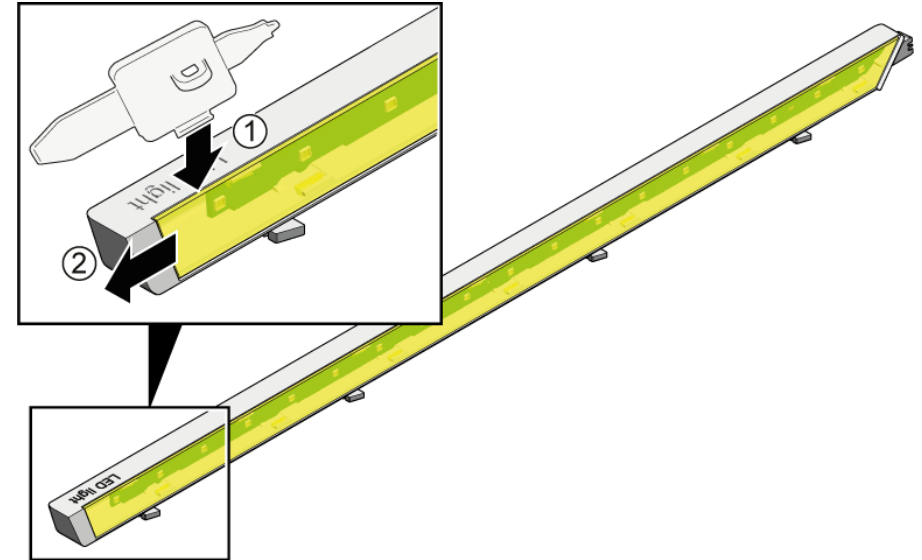

Remontas

1. Atpalaiduokite fiksavimo kabliuką, jį spustelėdami (1).
2. Išstumkite LED modulį iš korpuso aukštyn.
3. Nulaužkite LED modulio korpusą, kuris yra uždėtas ant atsarginių dalių joms apsaugoti transportuojant (3).

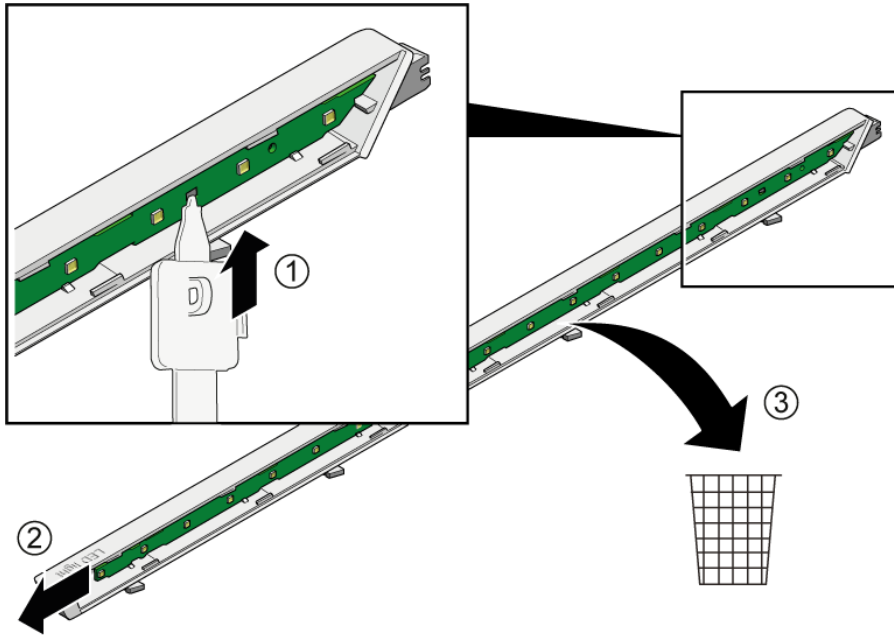

3. Įtaisykite LED modulį ir lemputės difuzorių atvirkščia eilės tvarka nei išimant.

4.16 LED šaldiklio lemputės pakeitimas

Specialūs įrankiai.

Specialus įrankis [00342180]

i Jūsų prietaise yra techninės priežiūros nereikalaujanti LED lemputė. Šias lemputes gali pataisyti tik klientų aptarnavimo tarnybos specialistai arba įgalioti technikai!

⚠ PAVOJUS
Elektros smūgio pavojus dėl dalių, kuriose yra įtampa!
Pavojus gyvybei dėl elektros smūgio netinkamo remonto atveju

- ▶ Elektrines dalis remontuoti turi kvalifikuoti elektrikai.
- ▶ Po remonto pasirūpinkite, kad būtų atliktas saugos bandymas pagal VDE 0701 arba šalyje galiojančius reglamentus.

⚠ PAVOJUS
Elektros smūgio pavojus dėl dalių, kuriose yra įtampa!
Mirtis dėl elektros smūgio

- ▶ Prieš pradėdami remontą, ne mažiau kaip prieš 60 sekundžių atjunkite prietaisus nuo elektros tiekimo.

⚠ PERSPĖJIMAS
Aštrios briaunos!
Galima įsipjauti

- ▶ Mūvėkite apsaugines pirštines.

Reikalavimas.

- ✔ Prietaisas atjungtas nuo maitinimo šaltinio.
- ✔ Durelės turi būti atidarytos.

4.16.1 LED šaldiklio lemputės išėmimas

- ▶ 1. Stumkite išardymo įrankį tarp lemputės ir korpuso lemputės pusėje, kad atsirastų tarpas (1).
- ▶ 2. Stumkite išardymo įrankį ant kitos lemputės tvirtinimo kablo pusės ir pasukite jį į priekį (2).
- ▶ 3. Nuimkite LED šaldiklio lemputę (3).

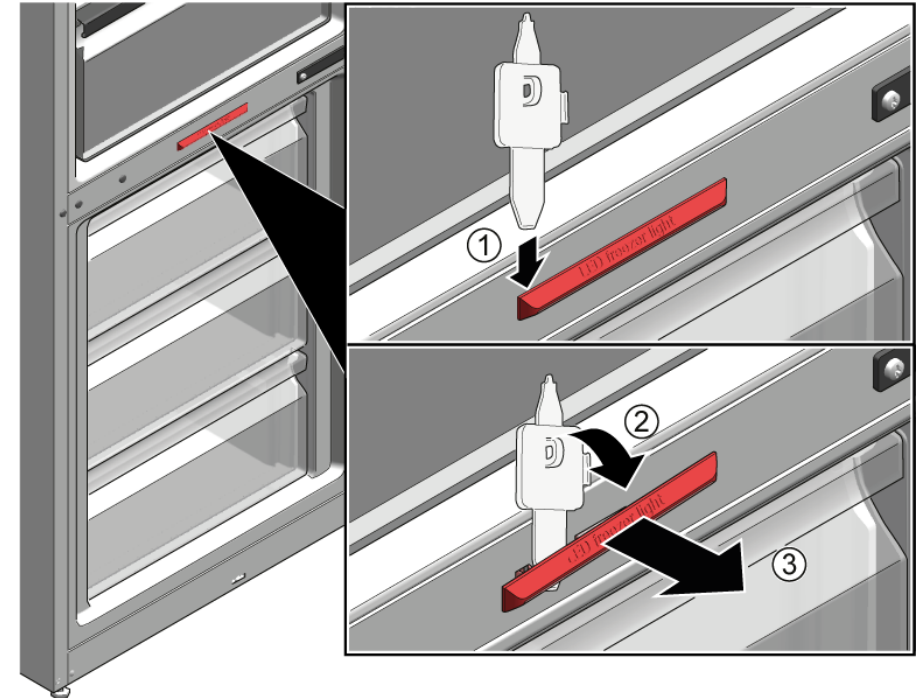

- ➡ LED šaldiklio lemputė yra atjungta.
- ➡ LED šaldiklio lemputė yra išimta.

4.16.2 LED šaldiklio lemputės įmontavimas

- ▶ Uždėkite atvirkščia eilės tvarka.

Reparasjonstips - Kjøle-/frysekombinasjon

 Om dette dokumentet	448
1.1 Viktig informasjon	448
1.1.1 Formål.....	448
1.2 Forklaring av symboler.....	448
1.2.1 Farenivåer	448
1.2.2 Faresymboler.....	448
1.2.3 Advarslenes struktur	449
1.2.4 Generelle symboler	449
 Sikkerhet	450
2.1 Generelle sikkerhetsinstruksjoner	450
2.1.1 Alle husholdningsapparater	450
 Verktøy og hjelpemidler	451
 Reparasjon	452
4.1 Utskiftning av dørpakning.....	452
4.1.1 Demontering av dørpakning.....	452
4.1.2 Montering av dørpakning	452
4.2 Utskiftning av dørhåndtak.....	455
4.2.1 Demontering av dørhåndtak	455
4.2.2 Montering av dørhåndtak.....	455
4.3 Utskiftning av øvre dørhengsel	456
4.3.1 Demontering av øvre dørhengsel	456
4.3.2 Montering av øvre dørhengsel	457
4.4 Utskiftning av øvre dørhengsel (dør med display)	458
4.4.1 Demontering av øvre dørhengsel	458
4.4.2 Montering av øvre dørhengsel	459
4.5 Utskiftning av midtre dørhengsel	460
4.5.1 Demontering av midtre dørhengsel	460
4.5.2 Montering av midtre dørhengsel.....	461
4.6 Utskiftning av nedre dørhengsel	462
4.6.1 Demontering av nedre dørhengsel	462
4.6.2 Montering av nedre dørhengsel	462
4.7 Utskiftning av hylle.....	463
4.7.1 Demontering av hylle.....	463
4.7.2 Montering av hylle	463

4.8 Utskiftning av flaskehylle	464
4.8.1 Demontering av flaskehylle	464
4.8.2 Montering av flaskehylle.....	464
4.9 Utskiftning av dørrack.....	465
4.9.1 Demontering av dørrack.....	465
4.9.2 Montering av dørrack	465
4.10 Utskiftning av oppbevaringsbeholder	466
4.10.1 Demontering av oppbevaringsbeholder	466
4.10.2 Montering av oppbevaringsbeholder	466
4.11 Utskiftning av frukt- og grønnsaksbeholder	467
4.11.1 Demontering av frukt- og grønnsaksbeholder	467
4.11.2 Montering av frukt- og grønnsaksbeholder	467
4.12 Utskiftning av hylle over frukt- og grønnsaksbeholder	468
4.12.1 Demontering av hylle over frukt- og grønnsaksbeholder.....	468
4.12.2 Montering av hylle over frukt- og grønnsaksbeholder	469
4.13 Utskiftning av beholder for frysevarer	470
4.13.1 Demontering av beholder for frysevarer	470
4.13.2 Montering av beholder for frysevarer	470
4.14 Utskiftning av øvre LED-lampe.....	471
4.14.1 Demontering av øvre LED-lampe.....	471
4.14.2 Montering av øvre LED-lampe	471
4.15 Utskiftning av LED-sidelampe	472
4.15.1 Demontering av LED-sidelampe	472
4.15.2 Montering av LED-sidelampe	473
4.16 Utskiftning av LED-lampe for fryser	475
4.16.1 Demontering av LED-lampe for fryser	475
4.16.2 Montering av LED-lampe for fryser	475

i Om dette dokumentet

1.1 Viktig informasjon

1.1.1 Formål

Disse tipsene om reparasjon skal hjelpe kunden til selv å kunne reparere apparater i samsvar med gjeldende regulering av øko-design (med gyldighet 03/2021).





De inneholder informasjon om hvordan definerte reservedeler skiftes, inklusive advarsler og risikoer.

Kontakt vår kundeservice dersom du har spørsmål. Vi påtar oss kun ansvar for skader dersom tipsene om reparasjon er korrekt fulgt.

1.2 Forklaring av symboler

1.2.1 Farenivåer

Advarslene som viser farenivå, består av et symbol og et signalord. Signalordet viser hvor alvorlig faren er.





Advarsel som viser farenivå	Betydning
 FARE	Dersom advarselen ignoreres, vil det føre til død eller alvorlige personskader.
 ADVARSEL	Dersom advarselen ignoreres, kan det føre til død eller alvorlige personskader.
 FORSIKTIG	Dersom advarselen ignoreres, kan det føre til mindre personskader.
 OBS!	Dersom advarselen ignoreres, kan det føre til materiell skade.

Tabell 1: Farenivåer



1.2.2 Faresymboler

Faresymboler er symbolske fremstillinger som gir en indikasjon av hvilken type fare det dreier seg om.

Følgende faresymboler brukes i dette dokumentet:

Faresymbol	Betydning
	Generell advarsel
	Fare for elektrisk støt
	Eksplisjonsfare
	Fare for å skjære seg
	Klemfare



i Om dette dokumentet

Faresymbol	Betydning
	Fare på grunn av varme overflater
	Fare på grunn av sterkt magnetfelt
	Fare fra ikke-ioniserende stråling



Tabell 2: Faresymboler

1.2.3 Advarslenes struktur

Advarslene i dette dokumentet har standardisert utseende og standardisert struktur.



	<div style="background-color: red; color: white; padding: 2px; text-align: center;">  FARE </div> <p>Faretype og kilde til fare! Mulige konsekvenser dersom fare/advarsel ignoreres.</p> <ul style="list-style-type: none"> ▶ Tiltak og forbud for å forebygge fare.
--	--







Eksemplet nedenfor viser en advarsel mot elektrisk støt på grunn av strømførende deler. Tiltaket for å unngå faren er angitt.

	<div style="background-color: red; color: white; padding: 2px; text-align: center;">  FARE </div> <p>Fare for elektrisk støt på grunn av strømførende deler! Død på grunn av drepende elektrisk støt</p> <ul style="list-style-type: none"> ▶ Koble apparatene fra strømforsyningen i minst 60 sekunder før reparasjonene startes.
---	--

1.2.4 Generelle symboler

Følgende generelle symboler brukes i dette dokumentet:

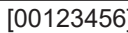
Gen. symbol	Betydning
	Identifisering av et spesielt tips (tekst og/eller grafikk)
	Identifisering av et enkelt tips (kun tekst)
	Identifisering av en lenke til en opplæringsvideo

Gen. symbol	Betydning
	Identifisering av nødvendig verktøy
	Identifisering av nødvendige forutsetninger
	Identifisering av en betingelse (hvis ..., så ...)
	Identifisering av et resultat
	Identifisering av en tast eller knapp
	Identifisering av et materialnummer
	Identifisering av vist tekst/vindu (i apparatets display)

Tabell 3: Generelle symboler

2.1 Generelle sikkerhetsinstruksjoner

2.1.1 Alle husholdningsapparater

Fare for elektrisk støt på grunn av strømførende deler!

- Feil ved reparasjoner hvor elektriske komponenter er involvert, kan føre til elektrisk støt!
- Koble apparatet fra strømmettet i minst 60 sekunder før arbeidet startes.
- Etter reparasjonen må du sørge for at det utføres en sikkerhetstest iht. VDE 0701 eller gjeldende forskrifter i det respektive land.

Fare for personskade på grunn av skarpe kanter!

- Bruk vernehansker.

Fare for å knuse legemsdeler under reparasjoner, vedlikehold, feilsøking og service på grunn av tunge og bevegelige komponenter

- Bruk vernesko.
- Sikre tunge komponenter for å hindre at de faller ned.
- Ikke stikk kroppsdelene inn i bevegelige komponenter.

Fare for apparatets sikkerhet/funksjon!

- Bruk kun originale reservedeler.

Fare for skade på deler som er følsomme overfor elektrostatisk utlading (ESD)!

- Ikke berør modulene, inklusive tilkoblinger og ledere.

Verktøy og hjelpemidler

Betegnelse	Detaljer	Bilder
Torx-bits TX20 [00340865]	6,3 mm (1/4")	
Spesialverktøy [00342180]		

4.1 Utskiftning av dørpakning

Forutsetning:

- ✔ Døren er åpen.

4.1.1 Demontering av dørpakning

1. Løsne dørpakningen fra sporet i høyre og venstre hjørne.

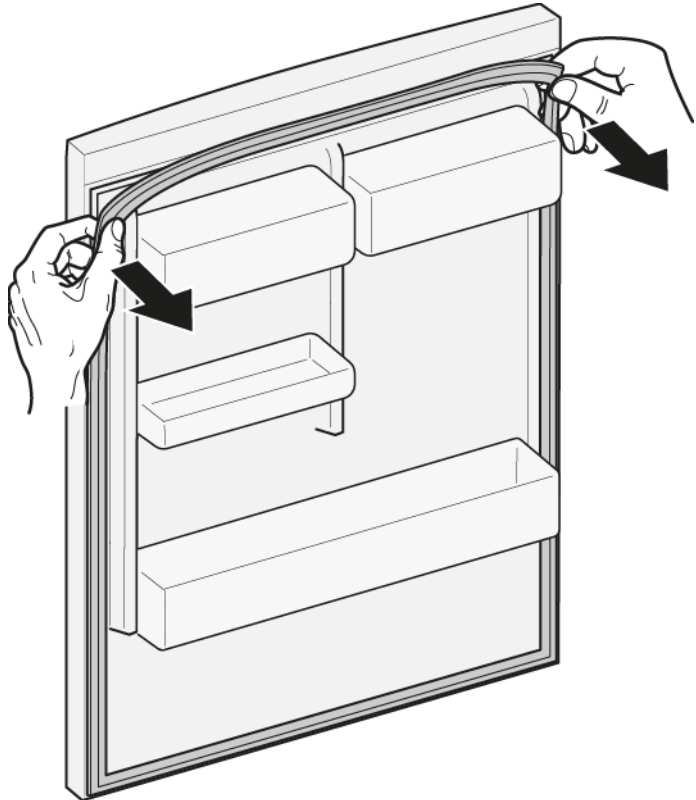

2. Trekk pakningen ut av sporet.

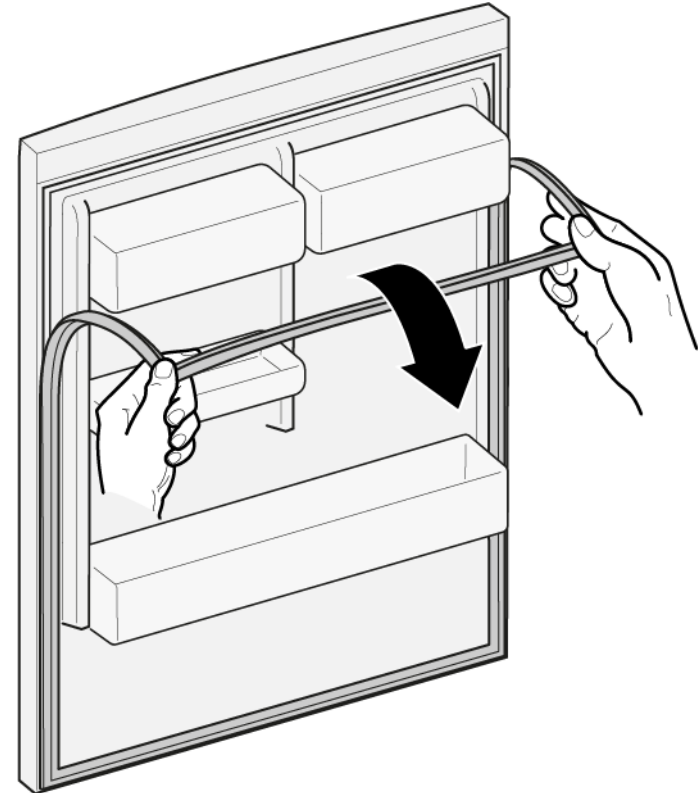

- ➡ Dørpakningen er demontert.

4.1.2 Montering av dørpakning



Tykkelsen på den nye dørpakningen kan avvike litt fra tykkelsen på den gamle dørpakningen. Det har ingen innvirkning på lukkeatferd og langvarig funksjon.

Hvis apparatet har justerbare hengsler eller hengslefester, kan du optimalisere lukkeatferden etterpå.

Små sidehull i dørpakningen har en funksjon (nødvendige for ventilasjonen). Det dreier seg ikke om produksjonsfeil.

Reparasjon

1. Kontroller at sporet for pakningen ikke har skader.

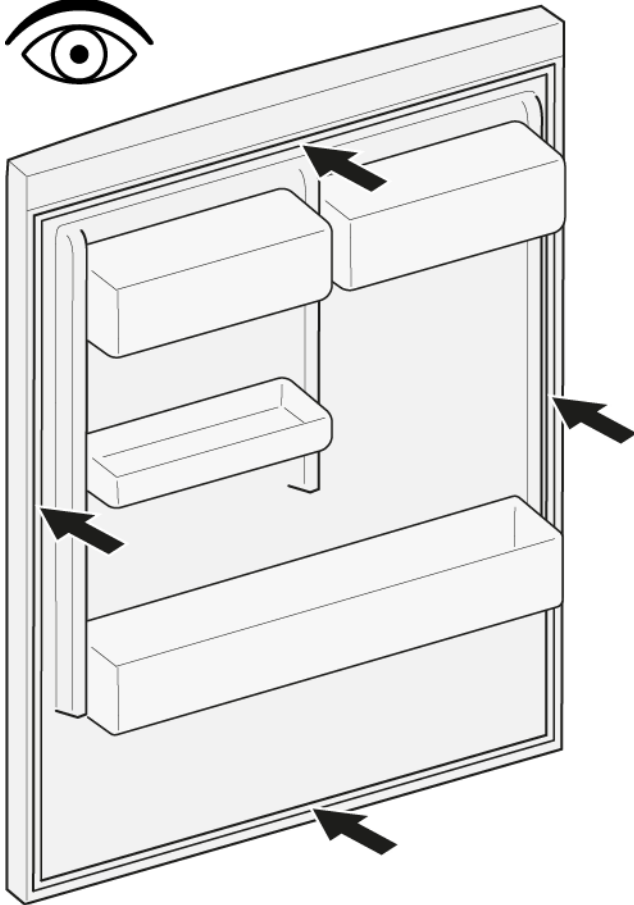

2.  Hvis sporet for pakningen er skadet:
 - Kontakt kundeservice.

3.  Litt deformasjon av dørpakningen er normalt og har ingen innvirkning på funksjonen. Det anbefales å rette ut dørpakningen før den settes inn i apparatet.

Varm opp dørpakningen med en føn eller varmt vann og form den på nytt med hendene.

4. Skyv pakningens hjørner øverst og nederst inn i sporet.

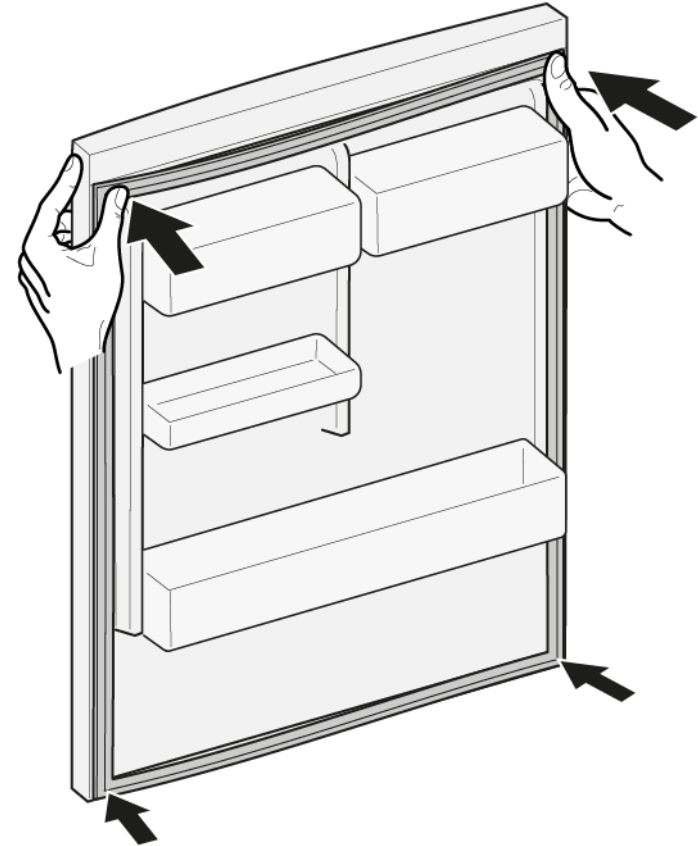

Reparasjon

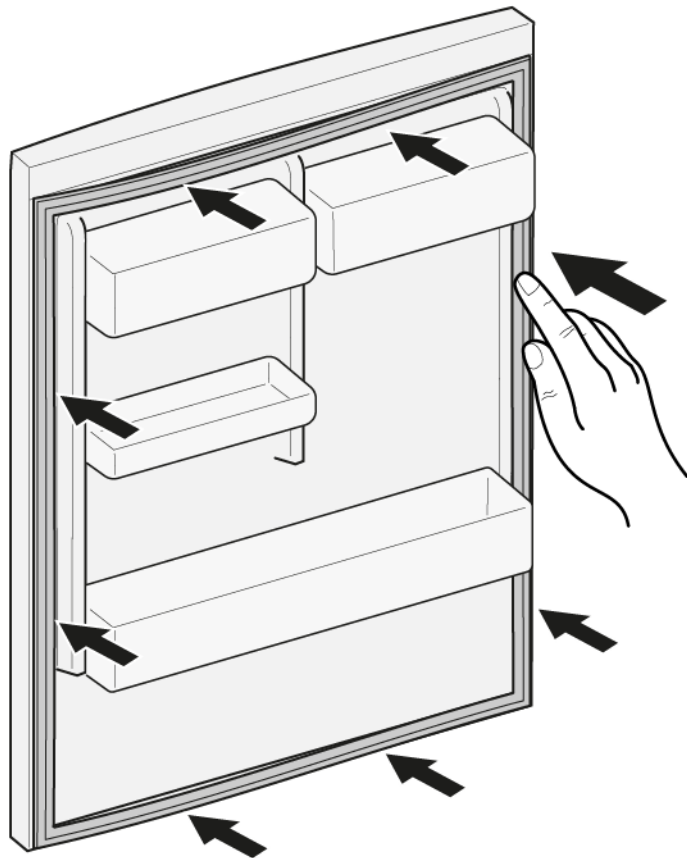

5. Trykk hele pakningen inn i sporet trinn for trinn.





 Dørpakningen er montert.

4.2 Utskiftning av dørhåndtak

Spesielle hjelpemidler:

-  Torx-bits TX20 6,3 mm (1/4") [00340865]
-  Flat skrutrekker Blad 10 mm x 1,6 mm x 200 mm

Forutsetning:

-  Apparatet kobles fra strømforsyningen.
-  Døren er åpen.

4.2.1 Demontering av dørhåndtak

- ▶ 1. Fjern to skruhetter (1).
- ▶ 2. Skru ut to skruer (2).
- ▶ 3. Demonter dørhåndtaket (3).

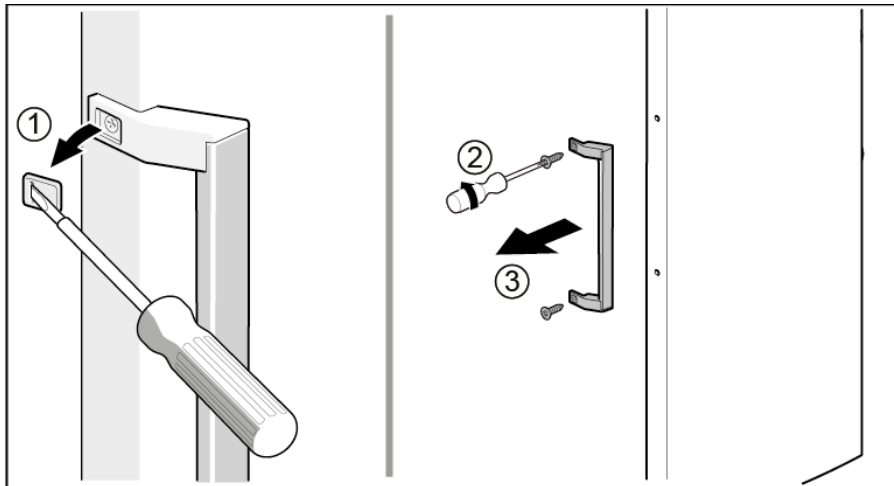

 Dørhåndtaket er demontert.



Dørhåndtaket for den andre døren kan demonteres på samme måte.

4.2.2 Montering av dørhåndtak

- ▶ Monteres i motsatt rekkefølge.

4.3 Utskiftning av øvre dørhengsel

Spesielle hjelpemidler:

Torx-bits TX20

6,3 mm (1/4")

[00340865]

	⚠ ADVARSEL
	<p>Tunge, klumpete apparater! Rygg- og muskelskader</p> <ul style="list-style-type: none"> ▶ Arbeidet med å demontere apparatets dør skal bare utføres av opplærte spesialister. ▶ Det kreves to personer for å flytte på apparatet. ▶ Bruk kun egnet verktøy og utstyr.

	⚠ FORSIKTIG
	<p>Skarpe kanter! Kuttskader</p> <ul style="list-style-type: none"> ▶ Bruk vernehansker.

	⚠ ADVARSEL
	<p>Tiltede apparater kan skli ut! Beinbrudd/klemskader</p> <ul style="list-style-type: none"> ▶ Sikre apparatene mot å skli ut.

	⚠ FORSIKTIG
	<p>Fare for at deler kan falle ned på grunn av løsnede skruer! Personskade på grunn av fallende deler.</p> <ul style="list-style-type: none"> ▶ Sikre komponenten så den ikke kan falle ned.

	OBS!
	<p>Fare for at deler kan falle ned på grunn av løsnede skruer! Skade på andre deler på apparatet eller i kundens hjem, f.eks. gulv.</p> <ul style="list-style-type: none"> ▶ Sikre komponenten så den ikke kan falle ned.

Forutsetning:

- ✓ Apparatet kobles fra strømforsyningen.
- ✓ Apparatets innvendige beslag er demontert.

4.3.1 Demontering av øvre dørhengsel

1. Skyv støttedelen under sokkeldelen.

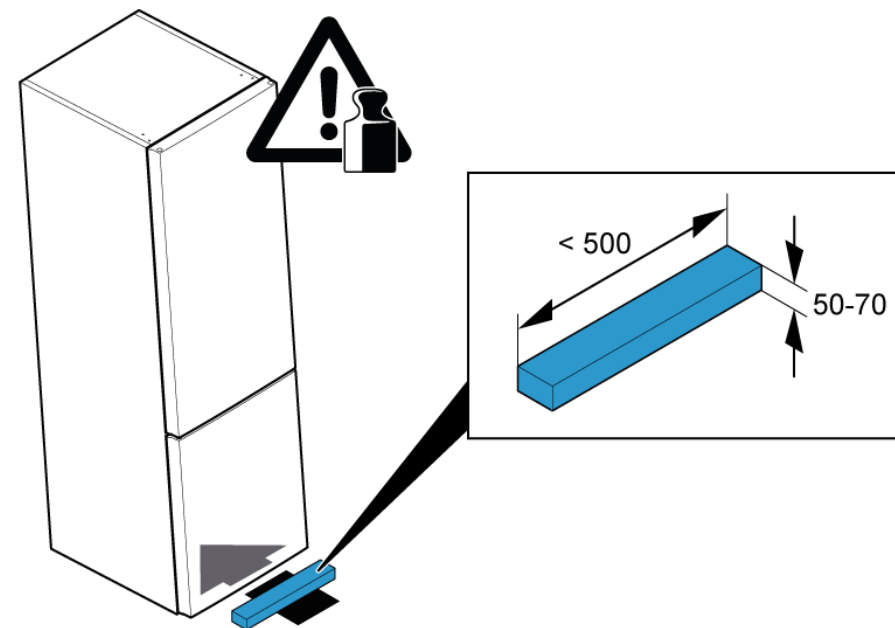

2. 1. Ta av det øvre hengseldekslet (1).
2. Skru ut to skruer (2).
3. Demonter øvre hengsel (3).

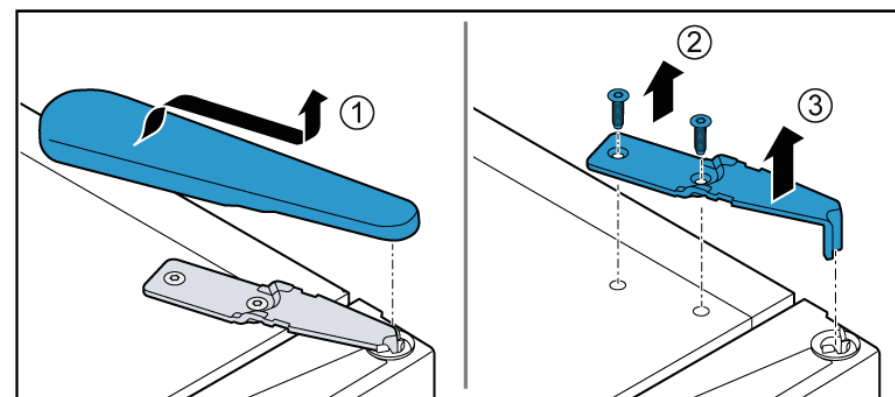

Reparasjon

3. Demonter den øvre døren.

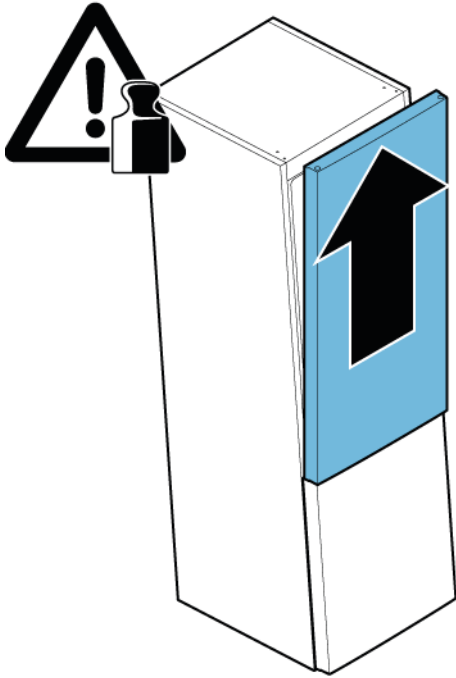

 Øvre hengsel er demontert.

4.3.2 Montering av øvre dørhengsel

▶ Monteres i motsatt rekkefølge.

4.4 Utskiftning av øvre dørhengsel (dør med display)

Spesielle hjelpemidler:

Torx-bits TX20 6,3 mm (1/4") [00340865]

	ADVARSEL Tunge, klumpete apparater! Rygg- og muskelskader <ul style="list-style-type: none">▶ Arbeidet med å demontere apparatets dør skal bare utføres av opplærte spesialister.▶ Det kreves to personer for å flytte på apparatet.▶ Bruk kun egnet verktøy og utstyr.
--	---

	FORSIKTIG Skarpe kanter! Kuttskader <ul style="list-style-type: none">▶ Bruk vernehansker.
--	--

	ADVARSEL Tiltede apparater kan skli ut! Beinbrudd/klemskader <ul style="list-style-type: none">▶ Sikre apparatene mot å skli ut.
--	--

	FORSIKTIG Fare for at deler kan falle ned på grunn av løsnede skruer! Personskade på grunn av fallende deler. <ul style="list-style-type: none">▶ Sikre komponenten så den ikke kan falle ned.
---	--

	OBS! Fare for at deler kan falle ned på grunn av løsnede skruer! Skade på andre deler på apparatet eller i kundens hjem, f.eks. gulv. <ul style="list-style-type: none">▶ Sikre komponenten så den ikke kan falle ned.
--	--

	FARE Fare for elektrisk støt på grunn av strømførende deler! Livsfare på grunn av elektrisk støt ved feil reparasjon <ul style="list-style-type: none">▶ Elektriske deler skal repareres av kvalifiserte elektrikere.▶ Etter reparasjonen må du sørge for at det utføres en sikkerhets-test iht. VDE 0701 eller gjeldende forskrifter i det respektive land.
---	---

	FARE Fare for elektrisk støt på grunn av strømførende deler! Død på grunn av drepende elektrisk støt <ul style="list-style-type: none">▶ Koble apparatene fra strømforsyningen i minst 60 sekunder før reparasjonene startes.
---	---

Forutsetning:

- ✓ Apparatet kobles fra strømforsyningen.
- ✓ Apparatets innvendige beslag er demontert.

4.4.1 Demontering av øvre dørhengsel

1. Skyv støttedelen under sokkeldelen.

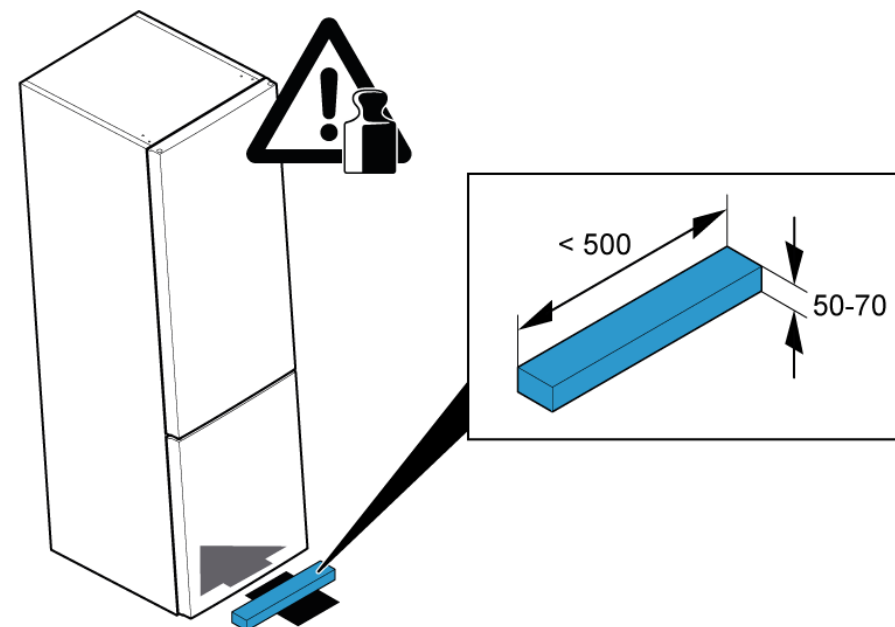

Reparasjon

2. 1. Ta av det øvre hengseldekslet (1).
2. Koble fra den elektriske tilkoblingen (2).
3. Skru ut skruen for jordkoblingen (3).

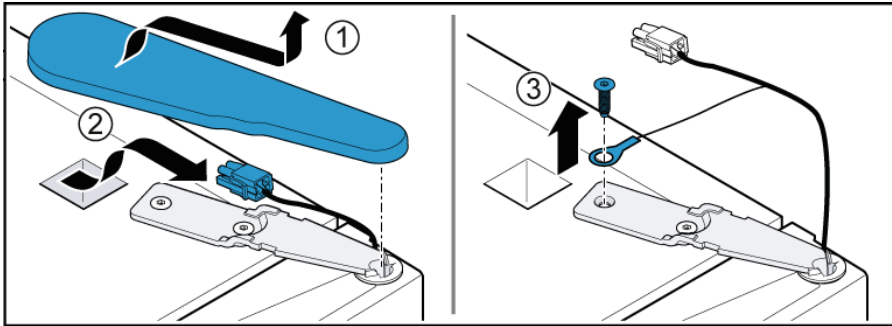

3. 1. Skru ut skruen (1).
2. Demonter øvre hengsel (2).

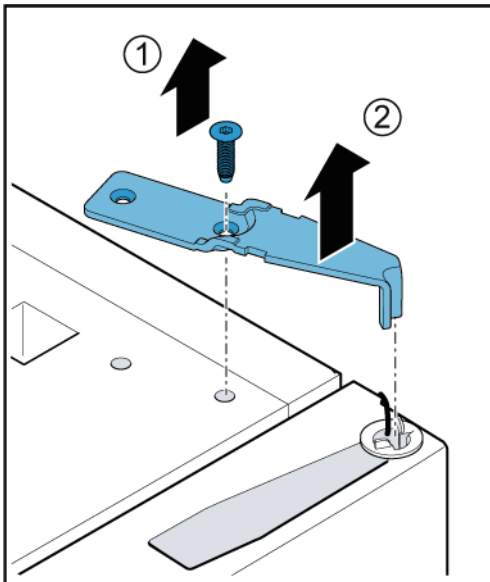

4. Demonter den øvre døren.

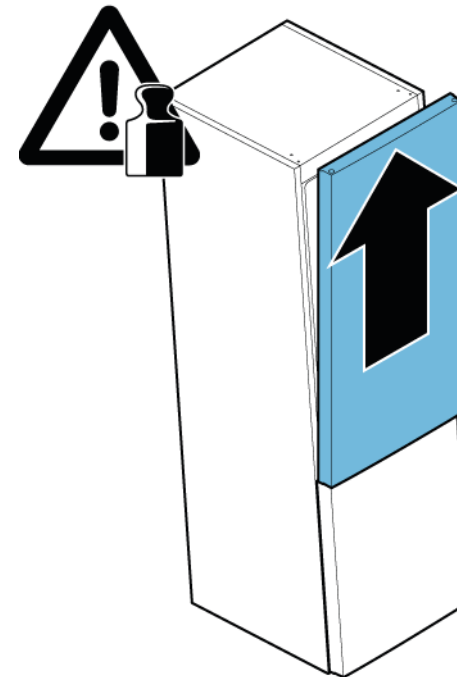

➡ Øvre hengsel er demontert.

4.4.2 Montering av øvre dørhengsel

- ▶ Monteres i motsatt rekkefølge.

4.5 Utskiftning av midtre dørhengsel

Spesielle hjelpemidler:

Torx-bits TX20

6,3 mm (1/4")

[00340865]

	ADVARSEL
	Tunge, klumpete apparater! Rygg- og muskelskader <ul style="list-style-type: none">▶ Arbeidet med å demontere apparatets dør skal bare utføres av opplærte spesialister.▶ Det kreves to personer for å flytte på apparatet.▶ Bruk kun egnet verktøy og utstyr.

	FORSIKTIG
	Skarpe kanter! Kuttskader <ul style="list-style-type: none">▶ Bruk vernehansker.

	ADVARSEL
	Tiltede apparater kan skli ut! Beinbrudd/klemskader <ul style="list-style-type: none">▶ Sikre apparatene mot å skli ut.

	FORSIKTIG
	Fare for at deler kan falle ned på grunn av løsnede skruer! Personskade på grunn av fallende deler. <ul style="list-style-type: none">▶ Sikre komponenten så den ikke kan falle ned.

	OBS!
	Fare for at deler kan falle ned på grunn av løsnede skruer! Skade på andre deler på apparatet eller i kundens hjem, f.eks. gulv. <ul style="list-style-type: none">▶ Sikre komponenten så den ikke kan falle ned.

Forutsetning:

- ✔ Apparatet kobles fra strømforsyningen.
- ✔ Apparatets innvendige beslag er demontert.
- ✔ Øvre dørhengsel er demontert.
- ✔ Øvre dør er demontert.

4.5.1 Demontering av midtre dørhengsel

1. Skru ut to skruer (1).
2. Demonter midtre hengsel (2).

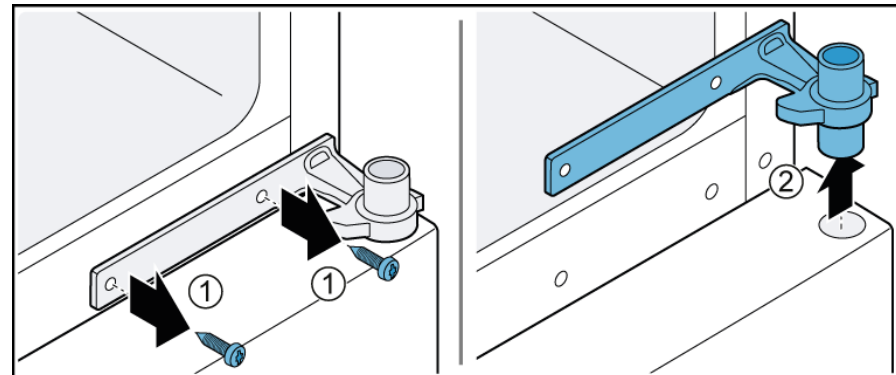

2. Demonter den nedre døren.

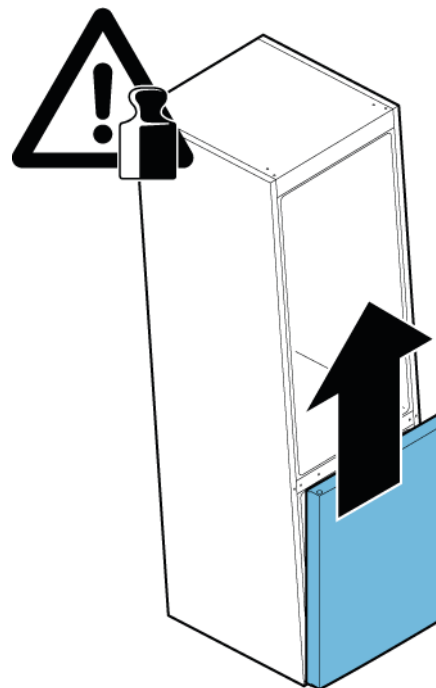

- ➡ Midtre hengsel er demontert.

4.5.2 Montering av midtre dørhengsel

- ▶ Monteres i motsatt rekkefølge.

4.6 Utskiftning av nedre dørhengsel

Spesielle hjelpemidler:

Torx-bits TX20

6,3 mm (1/4")

[00340865]

	ADVARSEL
	Tunge, klumpete apparater! Rygg- og muskelskader <ul style="list-style-type: none">Arbeidet med å demontere apparatets dør skal bare utføres av opplærte spesialister.Det kreves to personer for å flytte på apparatet.Bruk kun egnet verktøy og utstyr.

	FORSIKTIG
	Skarpe kanter! Kuttskader <ul style="list-style-type: none">Bruk vernehansker.

	ADVARSEL
	Tiltede apparater kan skli ut! Beinbrudd/klemskader <ul style="list-style-type: none">Sikre apparatene mot å skli ut.

	FORSIKTIG
	Fare for at deler kan falle ned på grunn av løsnede skruer! Personskade på grunn av fallende deler. <ul style="list-style-type: none">Sikre komponenten så den ikke kan falle ned.

	OBS!
	Fare for at deler kan falle ned på grunn av løsnede skruer! Skade på andre deler på apparatet eller i kundens hjem, f.eks. gulv. <ul style="list-style-type: none">Sikre komponenten så den ikke kan falle ned.

Forutsetning:

- ✓ Apparatet kobles fra strømforsyningen.
- ✓ Apparatets innvendige beslag er demontert.
- ✓ Øvre hengsel er demontert.
- ✓ Midtre hengsel er demontert.

4.6.1 Demontering av nedre dørhengsel

- 1. Skru ut to skruer (1).
- 2. Demonter nedre hengsel (2).

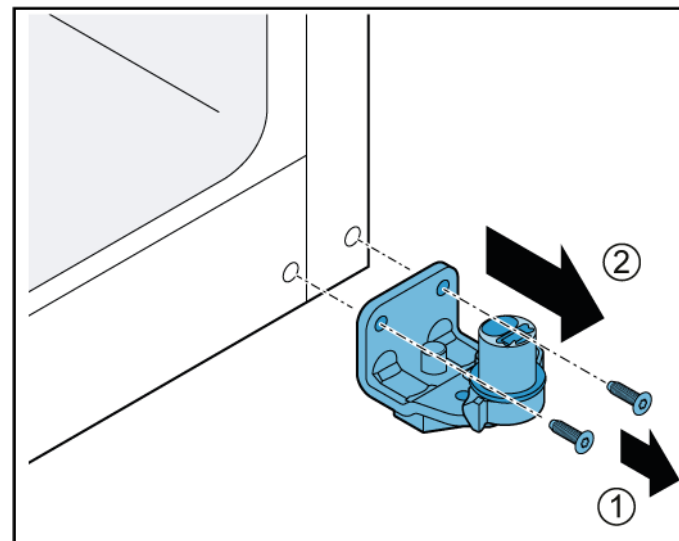

➡ Nedre dørhengsel er demontert.

4.6.2 Montering av nedre dørhengsel

- Monteres i motsatt rekkefølge.

4.7 Utskiftning av hylle

Forutsetning:

- ✔ Døren er åpen.

4.7.1 Demontering av hylle

- ▶ 1. Løft hyllen bak (1).
- ▶ 2. Løsne hyllen (2).

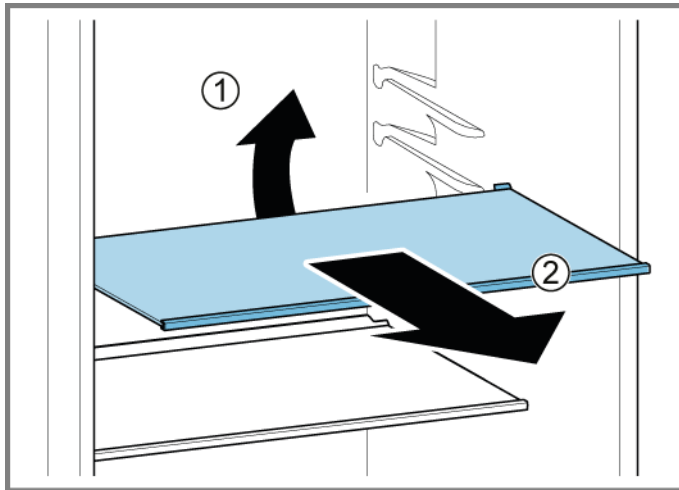

➡ Hyllen er demontert.

4.7.2 Montering av hylle

- ▶ Monteres i motsatt rekkefølge.

4.8 Utskiftning av flaskehylle

Forutsetning:

- ✔ Døren er åpen.

4.8.1 Demontering av flaskehylle

- ▶ Trekk ut flaskehyllen.

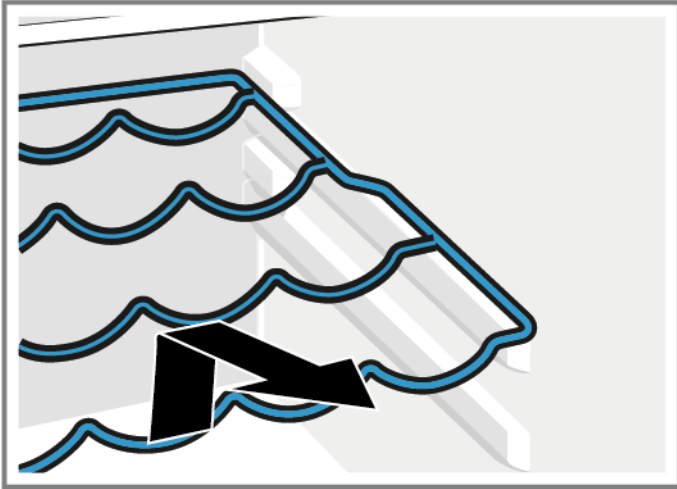

- ➡ Flaskehyllen er demontert.

4.8.2 Montering av flaskehylle

- ▶ Monteres i motsatt rekkefølge.

4.9 Utskiftning av dørrack

Forutsetning:

- ✔ Døren er åpen.

4.9.1 Demontering av dørrack

- ▶ Løft dørracken opp.

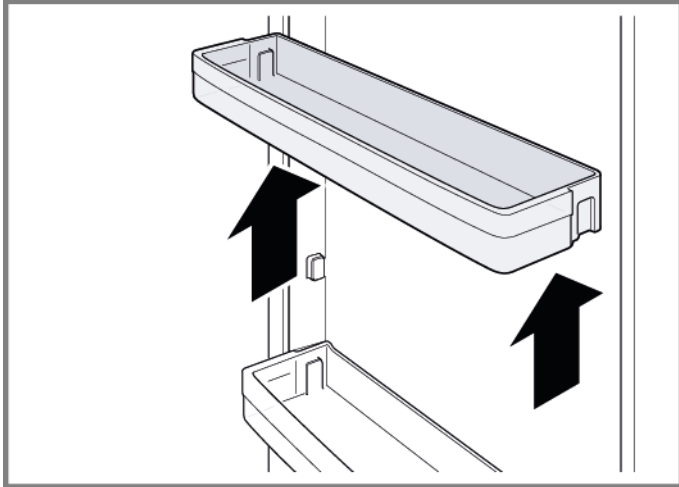

➡ Dørracken er demontert.

4.9.2 Montering av dørrack

- ▶ Monteres i motsatt rekkefølge.

4.10 Utskiftning av oppbevaringsbeholder

Forutsetning:

- ✔ Døren er åpen.

4.10.1 Demontering av oppbevaringsbeholder

1. Trekk ut oppbevaringsbeholderen så langt det går.
2. 1. Løft opp oppbevaringsbeholderen foran (1).
2. Fjern beholderen (2).

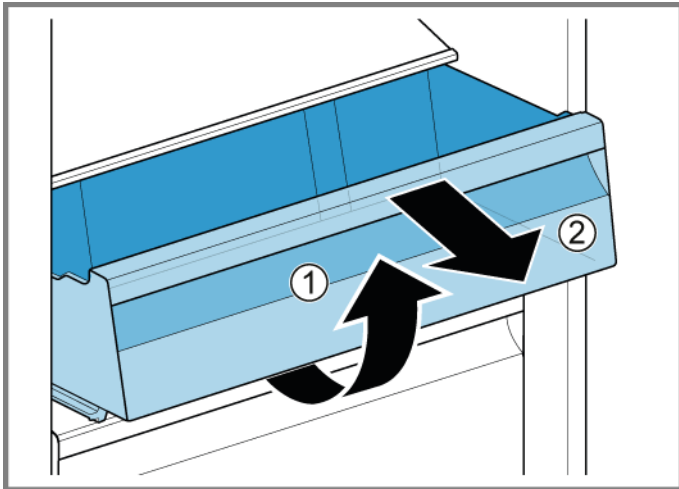

- ➡ Oppbevaringsbeholderen er demontert.

4.10.2 Montering av oppbevaringsbeholder

- ▶ Monteres i motsatt rekkefølge.

4.11 Utskiftning av frukt- og grønnsaksbeholder

Forutsetning:

- ✔ Døren er åpen.

4.11.1 Demontering av frukt- og grønnsaksbeholder

1. Trekk ut frukt- og grønnsaksbeholderen så langt det går.
2. 1. Løft frukt- og grønnsaksbeholderen foran (1).
2. Fjern beholderen (2).



- ➡ Frukt- og grønnsaksbeholderen er demontert.

4.11.2 Montering av frukt- og grønnsaksbeholder

- ▶ Monteres i motsatt rekkefølge.

4.12 Utskiftning av hylle over frukt- og grønnsaksbeholder

Forutsetning:

- ✔ Døren er åpen.
- ✔ [Frukt- og grønnsaksbeholderen er demontert.](#) →467

4.12.1 Demontering av hylle over frukt- og grønnsaksbeholder

1. Skyv tetterrammen oppover og ut.

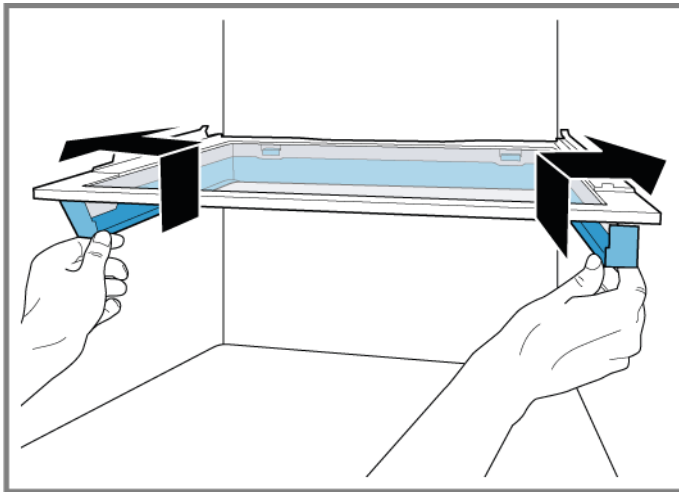

➡ Sidekrokene er løsnet.

2. Løft opp tetterrammen og skyv den bakover.

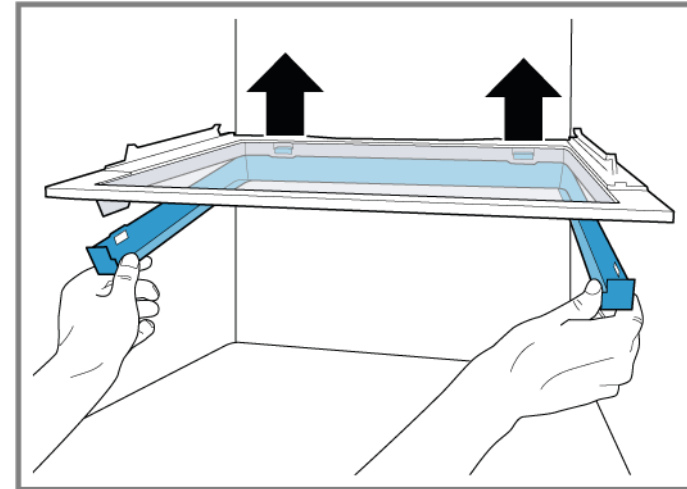

➡ Krokene bak er løsnet.

3. Demonter tetterrammen.
4. Løft opp hyllen over frukt- og grønnsaksbeholderen og sving den ut til siden.

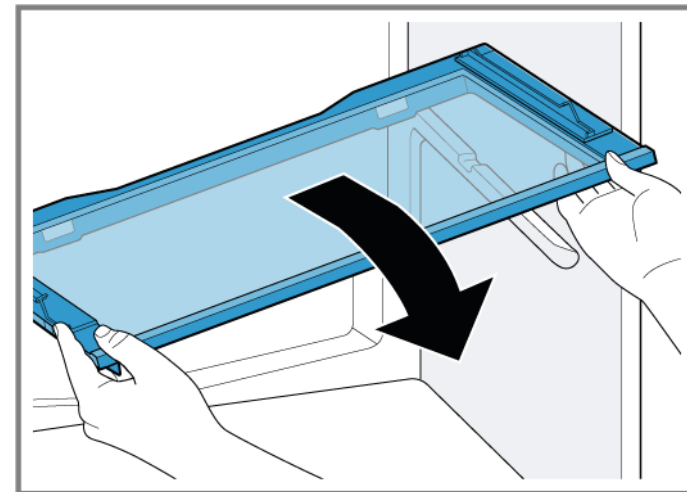

➡ Hyllen over frukt- og grønnsaksbeholderen er demontert.

4.12.2 Montering av hylle over frukt- og grønnsaksbeholder

- ▶ Monteres i motsatt rekkefølge.

4.13 Utskiftning av beholder for frysevarer

Forutsetning:

- ✔ Døren er åpen.

4.13.1 Demontering av beholder for frysevarer

- ▶ 1. Trekk beholderen for frysevarer helt ut (1).
- ▶ 2. Ta ut matbeholderen (2).

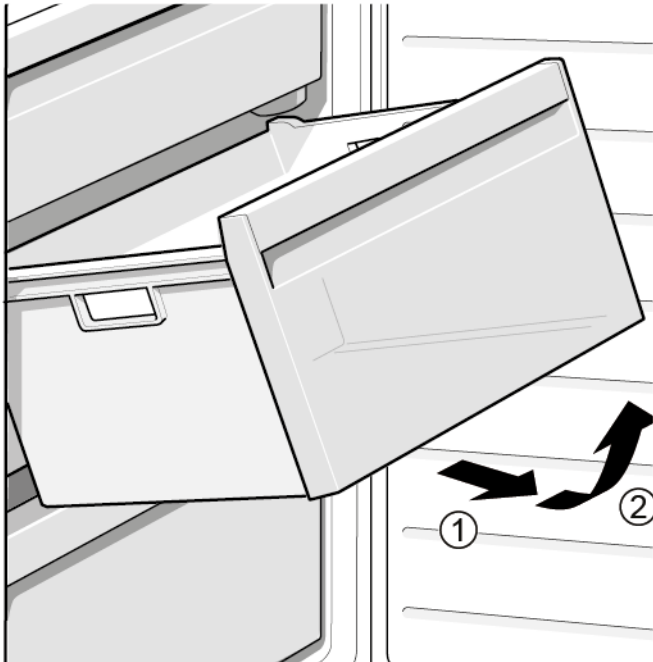

- ➡ Beholderen for frysevarer er demontert.

4.13.2 Montering av beholder for frysevarer

- ▶ Monteres i motsatt rekkefølge.

4.14 Utskiftning av øvre LED-lampe

Spesielle hjelpemidler:

Spesialverktøy

[00342180]



Apparatet har en vedlikeholdsfri LED-lampe.
Disse lampene skal kun repareres av kundeservice eller autoriserte teknikere!



FARE

Fare for elektrisk støt på grunn av strømførende deler!

Livsfare på grunn av elektrisk støt ved feil reparasjon

- ▶ Elektriske deler skal repareres av kvalifiserte elektrikere.
- ▶ Etter reparasjonen må du sørge for at det utføres en sikkerhetstest iht. VDE 0701 eller gjeldende forskrifter i det respektive land.



FARE

Fare for elektrisk støt på grunn av strømførende deler!

Død på grunn av drepende elektrisk støt

- ▶ Koble apparatene fra strømforsyningen i minst 60 sekunder før reparasjonene startes.



FORSIKTIG

Skarpe kanter!

Kuttskader

- ▶ Bruk vernehansker.

Forutsetning:

- ✓ Apparatet kobles fra strømforsyningen.
- ✓ Døren er åpen.

4.14.1 Demontering av øvre LED-lampe

1. Skyv demonteringsverktøyet mellom den øvre LED-lampen og kjøleskappens innerbelegg for å løsne lampekrokkene (1).
2. Demonter den øvre LED-lampen (2).

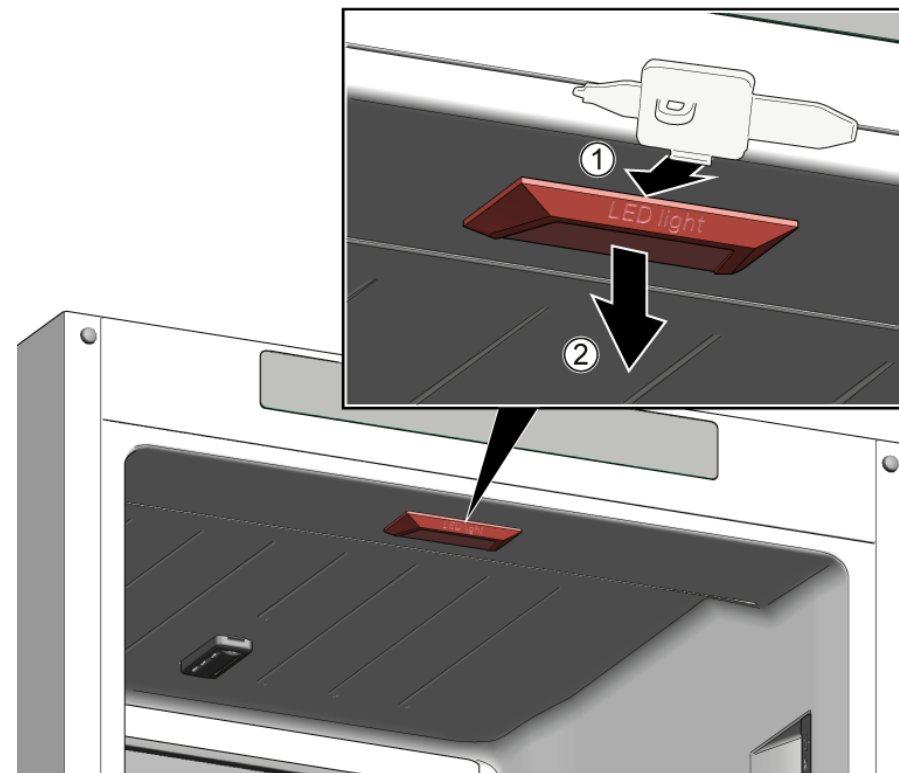

2. Koble fra den elektriske tilkoblingen for den øvre LED-lampen.
- ➡ Den øvre LED-lampen er demontert.

4.14.2 Montering av øvre LED-lampe

- ▶ Monteres i motsatt rekkefølge.

4.15 Utskiftning av LED-sidelampe

Spesielle hjelpemidler:

Spesialverktøy

[00342180]



Apparatet har en vedlikeholdsfri LED-lampe.
Disse lampene skal kun repareres av kundeservice eller autoriserte teknikere!



FARE

Fare for elektrisk støt på grunn av strømførende deler!

Livsfare på grunn av elektrisk støt ved feil reparasjon

- ▶ Elektriske deler skal repareres av kvalifiserte elektrikere.
- ▶ Etter reparasjonen må du sørge for at det utføres en sikkerhetstest iht. VDE 0701 eller gjeldende forskrifter i det respektive land.



FARE

Fare for elektrisk støt på grunn av strømførende deler!

Død på grunn av døpende elektrisk støt

- ▶ Koble apparatene fra strømforsyningen i minst 60 sekunder før reparasjonene startes.



FORSIKTIG

Skarpe kanter!

Kuttskader

- ▶ Bruk vernehansker.



OBS!

Fare for skade på deler som er følsomme overfor elektrostatisk utlading (ESD)!

Skader på komponenter

- ▶ Før du berører ESD-er må du bruke et beskyttelsessystem mot elektrostatisk utlading (jordingsarmbånd).
- ▶ Ikke berør tilkoblingene og lederbanene for modulene.
- ▶ ESD-er må bare transporteres i ledende materialer eller originalemballasje.
- ▶ Hold ESD-er unna elektrostatisk oppladbare materialer (f.eks. plast).

Forutsetning:

- ✓ Apparatet kobles fra strømforsyningen.
- ✓ Døren er åpen.
- ✓ De innvendige RC-beslagene er demontert.

4.15.1 Demontering av LED-sidelampe

1. Skyv demonteringsverktøyet mellom lampediffusoren og huset for å frigjøre kroken (1).
2. Ta ut lampediffusoren (2).
3. Frigjør diffusorfestekrokene etter hverandre på samme måte.

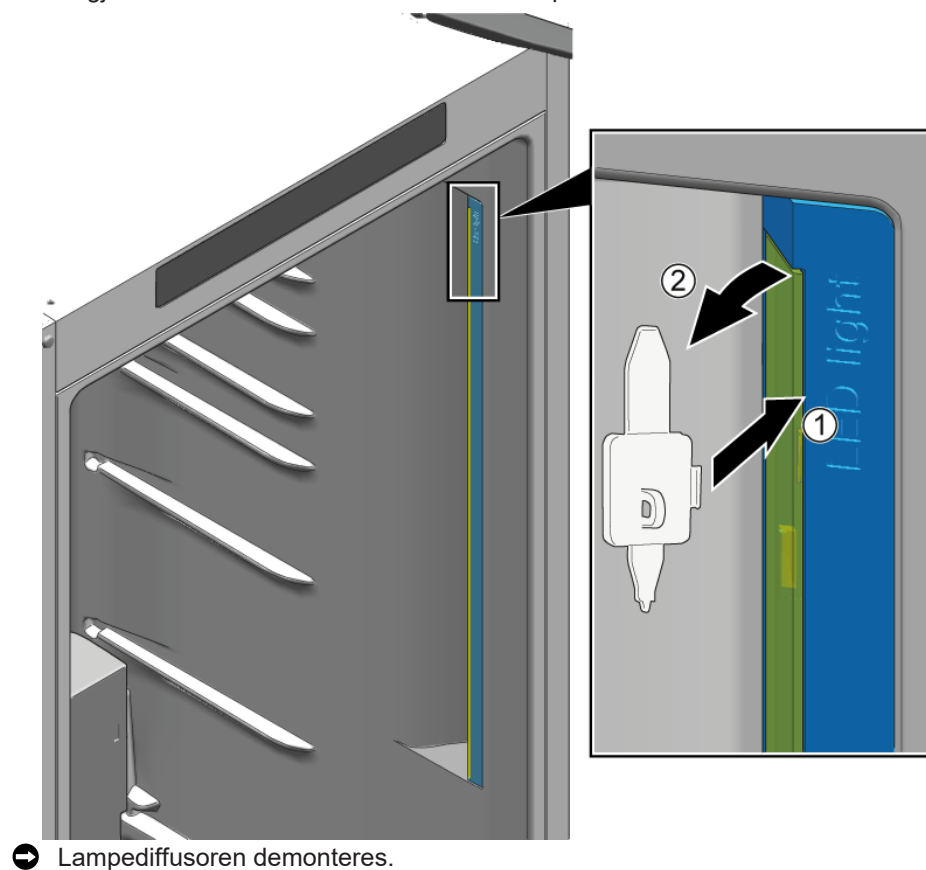

➔ Lampediffusoren demonteres.

Reparasjon

1. Trykk på festekroken for å løsne den (1).
2. Beveg LED-modulen opp ca. 1 cm for å demontere den fra den elektriske kontakten (2).
3. Demonter LED-modulen (3).

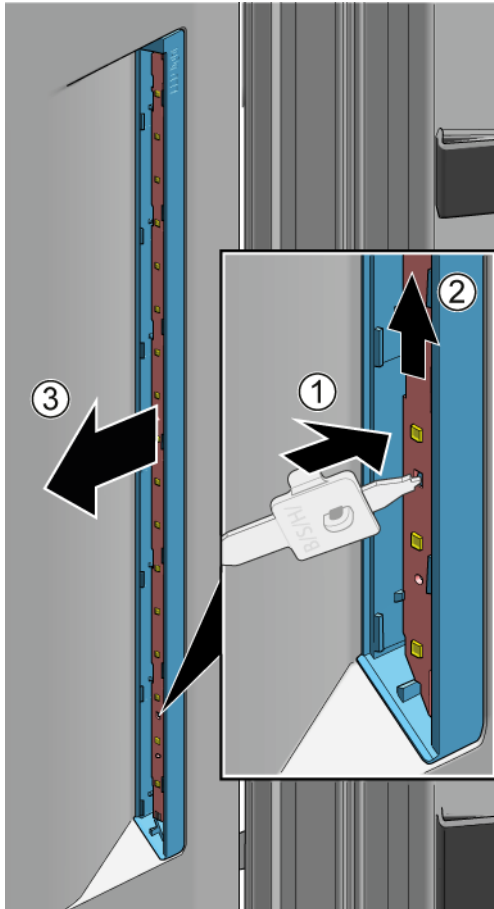

 LED-sidelampen er demontert.

4.15.2 Montering av LED-sidelampe



Etttersom lampediffusorkrokene lett kan brette under demonteringen, finnes det en LED-sidelampe i settet som inkluderer LED-modul og lampediffusor.

1. Skyv demonteringsverktøyet mellom lampediffusoren og huset for å frigjøre kroken (1).
2. Ta ut lampediffusoren (2).
3. Frigjør diffusorfestekrokene etter hverandre på samme måte.

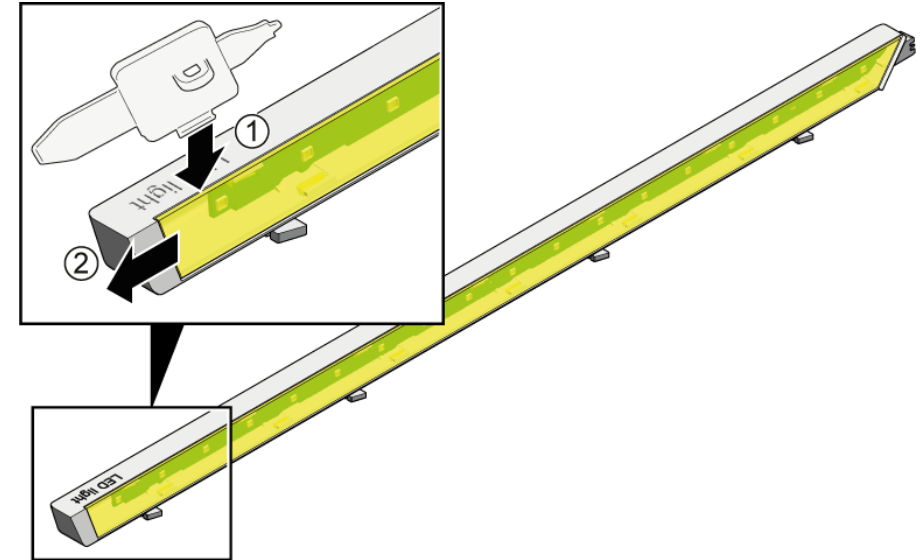

Reparasjon

1. Trykk på festekroken for å løsne den (1).
2. Skyv LED-modulen opp og ut av huset.
3. Kasser LED-modulhuset som brukes for transport av reservedelen av sikkerhetsmessige årsaker (3).

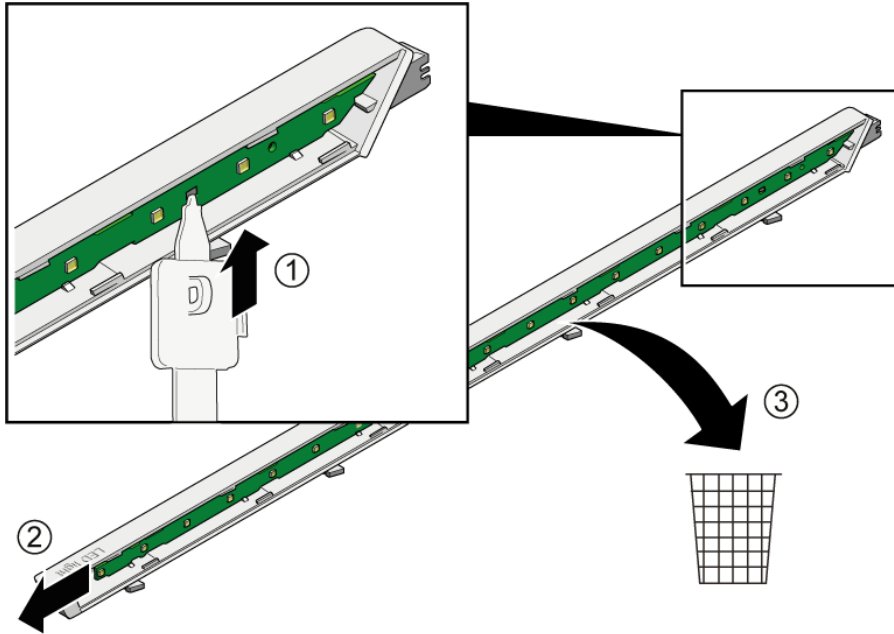

3. Monter LED-modulen og lampediffusoren i motsatt rekkefølge i forhold til demonteringen.

4.16 Utskiftning av LED-lampe for fryser

Spesielle hjelpemidler:

Spesialverktøy [00342180]

i Apparatet har en vedlikeholdsfri LED-lampe.
Disse lampene skal kun repareres av kundeservice eller autoriserte teknikere!

FARE
Fare for elektrisk støt på grunn av strømførende deler!
Livsfare på grunn av elektrisk støt ved feil reparasjon

- ▶ Elektriske deler skal repareres av kvalifiserte elektrikere.
- ▶ Etter reparasjonen må du sørge for at det utføres en sikkerhets-test iht. VDE 0701 eller gjeldende forskrifter i det respektive land.

FARE
Fare for elektrisk støt på grunn av strømførende deler!
Død på grunn av drepende elektrisk støt

- ▶ Koble apparatene fra strømforsyningen i minst 60 sekunder før reparasjonene startes.

FORSIKTIG
Skarpe kanter!
Kuttskader

- ▶ Bruk vernehansker.

Forutsetning:

- ✓ Apparatet kobles fra strømforsyningen.
- ✓ Døren er åpen.

4.16.1 Demontering av LED-lampe for fryser

- ▶ 1. Skyv demonteringsverktøyet mellom lampen og huset på siden av lampen for å lage en åpning (1).
- ▶ 2. Skyv demonteringsverktøyet på den andre siden av lampefestekroken, og dreii det forover (2).
- ▶ 3. Demonter LED-lampen for fryseren (3).

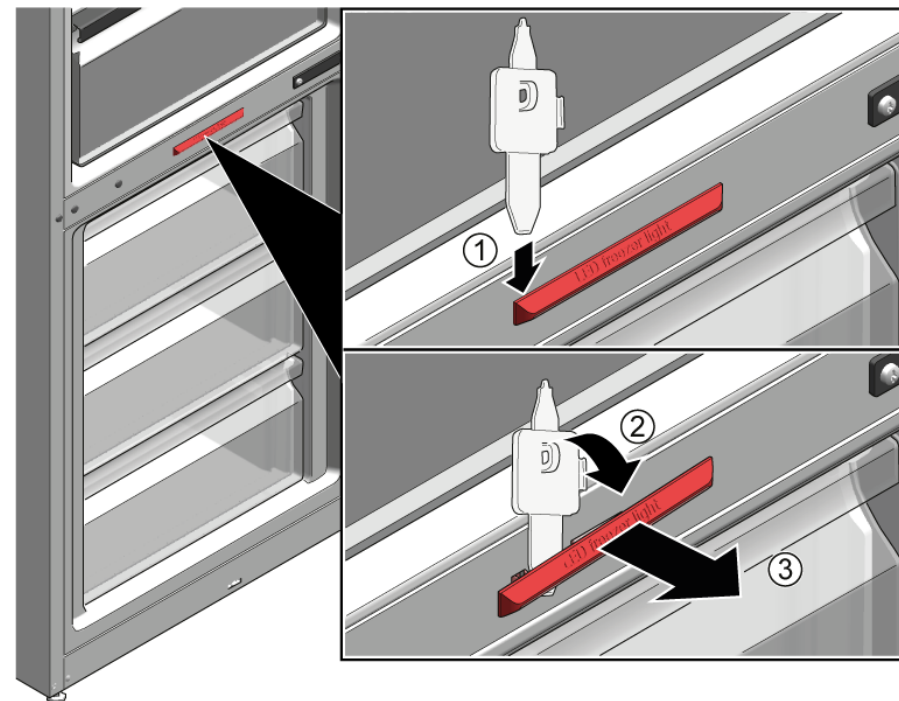





- ➡ LED-lampen for fryseren er koblet fra.
- ➡ LED-lampen for fryseren er demontert.

4.16.2 Montering av LED-lampe for fryser

- ▶ Monteres i motsatt rekkefølge.

Wskazówki naprawy - Chłodziarko-zamrażarka

 Informacje dotyczące dokumentu	477
1.1 Ważne informacje	477
1.1.1 Cel dokumentu	477
1.2 Objaśnienie symboli ostrzegawczych	477
1.2.1 Oznaczenie poziomów niebezpieczeństwa	477
1.2.2 Symbole ostrzegawcze	477
1.2.3 Budowa ostrzeżeń	478
1.2.4 Ogólne symbole	478
 Bezpieczeństwo	479
2.1 Ogólne informacje dotyczące bezpieczeństwa	479
2.1.1 Wszystkie sprzęty gospodarstwa domowego	479
 Narzędzia i pomoce techniczne	480
 Naprawy	481
4.1 Wymiana uszczelki drzwiczek	481
4.1.1 Demontaż uszczelki drzwiczek	481
4.1.2 Montaż uszczelki drzwiczek	481
4.2 Wymiana uchwytu drzwiczek	484
4.2.1 Demontaż uchwytu drzwiczek	484
4.2.2 Montaż uchwytu drzwiczek	484
4.3 Wymiana górnego zawiasu drzwiczek	485
4.3.1 Demontaż górnego zawiasu drzwiczek	485
4.3.2 Montaż górnego zawiasu drzwiczek	486
4.4 Wymiana górnego zawiasu drzwiczek (drzwiczki z wyświetlaczem)	487
4.4.1 Demontaż górnego zawiasu drzwiczek	488
4.4.2 Montaż górnego zawiasu drzwiczek	489
4.5 Wymiana środkowego zawiasu drzwiczek	490
4.5.1 Demontaż środkowego zawiasu drzwiczek	490
4.5.2 Montaż środkowego zawiasu drzwiczek	491
4.6 Wymiana dolnego zawiasu drzwiczek	492
4.6.1 Demontaż dolnego zawiasu drzwiczek	492
4.6.2 Montaż dolnego zawiasu drzwiczek	492
4.7 Wymiana półki	493
4.7.1 Demontaż półki	493
4.7.2 Montaż półki	493
4.8 Wymiana podstawki na butelki	494
4.8.1 Demontaż podstawki na butelki	494
4.8.2 Montaż podstawki na butelki	494
4.9 Wymiana półki drzwiczek	495
4.9.1 Demontaż półki drzwiczek	495
4.9.2 Montaż półki drzwiczek	495
4.10 Wymiana pojemnika do przechowywania	496
4.10.1 Demontaż pojemnika do przechowywania	496
4.10.2 Montaż pojemnika do przechowywania	496
4.11 Wymiana pojemnika na owoce i warzywa	497
4.11.1 Demontaż pojemnika na owoce i warzywa	497
4.11.2 Montaż pojemnika na owoce i warzywa	497
4.12 Wymiana półki nad pojemnikiem na owoce i warzywa	498
4.12.1 Demontaż półki nad pojemnikiem na owoce i warzywa	498
4.12.2 Montaż półki nad pojemnikiem na owoce i warzywa	499
4.13 Wymiana pojemnika na mrożoną żywność	500
4.13.1 Demontaż pojemnika na mrożoną żywność	500
4.13.2 Montaż pojemnika na mrożoną żywność	500
4.14 Wymiana górnej żarówki LED	501
4.14.1 Demontaż górnej żarówki LED	501
4.14.2 Montaż górnej żarówki LED	501
4.15 Wymiana bocznej żarówki LED	502
4.15.1 Demontaż bocznej żarówki LED	503
4.15.2 Montaż bocznej żarówki LED	503
4.16 Wymiana żarówki LED w zamrażarce	505
4.16.1 Demontaż żarówki LED w zamrażarce	505
4.16.2 Montaż żarówki LED w zamrażarce	505

i Informacje dotyczące dokumentu

1.1 Ważne informacje

1.1.1 Cel dokumentu

Niniejsze wskazówki naprawcze mają na celu zapewnienie użytkownikowi pomocy w samodzielnej naprawie posiadanych urządzeń w sposób zgodny z obowiązującymi przepisami w sprawie ekoprojektu (stan na 03/2021).

Zawierają one informacje na temat wymiany określonych części zamiennych oraz ostrzeżenia i informacje o zagrożeniach.

W razie pytań należy się skontaktować z naszym działem serwisowym. Odpowiedzialność za szkody ponosimy tylko pod warunkiem prawidłowego stosowania się do wskazówek naprawczych.

1.2 Objasnienie symboli ostrzegawczych

1.2.1 Oznaczenie poziomów niebezpieczeństwa

Poziom ryzyka jest określany przy pomocy symbolu oraz wyrazu. Wyraz określa poziom ryzyka.



Symbol	Znaczenie
 NIEBEZPIECZEŃSTWO	Bezpośrednio zagrażające niebezpieczeństwo, które przy niezachowaniu odpowiednich środków ostrożności może doprowadzić do śmierci lub poważnych obrażeń.
 OSTRZEŻENIE	Prawdopodobieństwo wystąpienia niebezpieczeństwa, które przy niezachowaniu odpowiednich środków ostrożności może doprowadzić do śmierci lub poważnych obrażeń.
 WAŻNE	Prawdopodobieństwo wystąpienia niebezpieczeństwa, które przy niezachowaniu odpowiednich środków ostrożności może doprowadzić do powstania lekkich obrażeń.
UWAGA!	Ostrzeżenie dot. możliwości powstania szkody materialnej.

Tabela 1: Oznaczenie poziomów niebezpieczeństwa

1.2.2 Symbole ostrzegawcze

Symbole ostrzegawcze reprezentują graficznie źródło potencjalnego ryzyka.

W poniższym dokumencie użyto następujących symboli:

Symbole ostrzegawcze	Znaczenie
	Ogólne ostrzeżenie
	Niebezpieczeństwo od napięcia elektrycznego
	Ryzyko wybuchu

i Informacje dotyczące dokumentu







Symbole ostrzegawcze	Znaczenie
	Ryzyko obrażeń (rozcięć)
	Ryzyko zmiążdżenia
	Ryzyko oparzenia
	Silne pole magnetyczne
	Promieniowanie nie-jonizujące

Tabela 2: Symbole ostrzegawcze

1.2.3 Budowa ostrzeżeń

Ostrzeżenia podane w dokumencie mają standardową budowę.

	<p>⚠ NIEBEZPIECZEŃSTWO</p> <p>Typ i źródło ryzyka!! Konsekwencje zignorowania.</p> <ul style="list-style-type: none"> ▶ Środki ochronne.
---	---

Kolejne ostrzeżenie wskazuje, jako źródło możliwość porażenia prądem. Wskazano czynności, które mają za zadanie ograniczenie ryzyka.

	<p>⚠ NIEBEZPIECZEŃSTWO</p> <p>Ryzyko porażenia prądem, ze względu na elementy będące pod napięciem! Zagrożenie życia poprzez porażenie prądem</p> <ul style="list-style-type: none"> ▶ Odłączyć urządzenie od zasilania sieciowego na 60 sekund przed rozpoczęciem naprawy.
--	--

1.2.4 Ogólne symbole

Poniższe symbole są używane w dokumentacji:







Symbol	Znaczenie
	Identyfikacja specjalnej wskazówki (tekst lub grafika)
	Identyfikacja prostej wskazówki (tylko tekst)
	Identyfikacja linku do pliku wideo
	Identyfikacja narzędzi
	Identyfikacja wstępnych warunków
	Identyfikacja warunku (jeżeli)
	Identyfikacja rezultatu
[Start]	Identyfikacja przycisku
[00123456]	Identyfikacja numeru materiału
Status	Identyfikacja wyświetlanego tekstu / komunikatu (na wyświetlaczu)

Tabela 3: Ogólne symbole

2.1 Ogólne informacje dotyczące bezpieczeństwa

2.1.1 Wszystkie sprzęty gospodarstwa domowego

Ryzyko porażenia prądem elektrycznym wskutek kontaktu z elementami znajdującymi się pod napięciem!

- Błędna naprawa części elektrycznych może spowodować porażenie prądem elektrycznym!
- Co najmniej 60 sekund przed przystąpieniem do pracy odłączyć urządzenie od sieci elektrycznej.
- Po naprawie należy przeprowadzić test bezpieczeństwa zgodny z przepisami normy VDE 0701 (Niemcy) lub odpowiednimi przepisami obowiązującymi w kraju użytkownika.

Ryzyko zranienia o ostre krawędzie!

- Używać rękawic ochronnych.

Ryzyko zmiżdżenia podczas naprawy, obsługi lub diagnozy, ze względu na ciężkie i ruchome elementy

- Stosować obuwie ochronne.
- Zabezpieczyć ciężkie elementy przed upadkiem.
- Nie dotykać ruchomych elementów podczas pracy urządzenia.

Zagrożenie dla bezpieczeństwa użytkownika i działania urządzenia!

- Używać tylko oryginalnych części zamiennych.

Ryzyko uszkodzenia komponentów wrażliwych na wyładowania elektrostatyczne (ESD)!

- Nie dotykać modułów, włącznie ze złączami i ścieżkami przewodzącymi.

Narzędzia i pomoce techniczne

Przeznaczenie	Detale	Zdjęcia
Torx Bit TX20 [00340865]	6,3 mm (1/4")	
Narzędzie specjalne [00342180]		

4.1 Wymiana uszczelki drzwiczek

Warunek:

- ✔ Drzwiczki są otwarte.

4.1.1 Demontaż uszczelki drzwiczek

1. Poluzować uszczelkę drzwiczek w rowku w prawym i lewym narożniku.



2. Wyciągnąć uszczelkę drzwiczek z rowka.



- ➡ Uszczelka drzwiczek została zdemontowana.

4.1.2 Montaż uszczelki drzwiczek



Grubość nowej uszczelki drzwiczek może się nieco różnić od grubości starej uszczelki drzwiczek. Nie ma to wpływu na jakość zamykania drzwiczek i i działanie urządzenia.

Jeżeli urządzenie posiada regulowane zawiasy lub elementy mocujące zawiasów, można przy ich użyciu regulować sposób zamykania drzwiczek.

Małe boczne otwory w uszczelce drzwiczek są elementami funkcyjnymi (zapewniają wentylację). Nie stanowią one wad produkcyjnych.

1. Skontrolować rowek uszczelki pod kątem uszkodzeń.

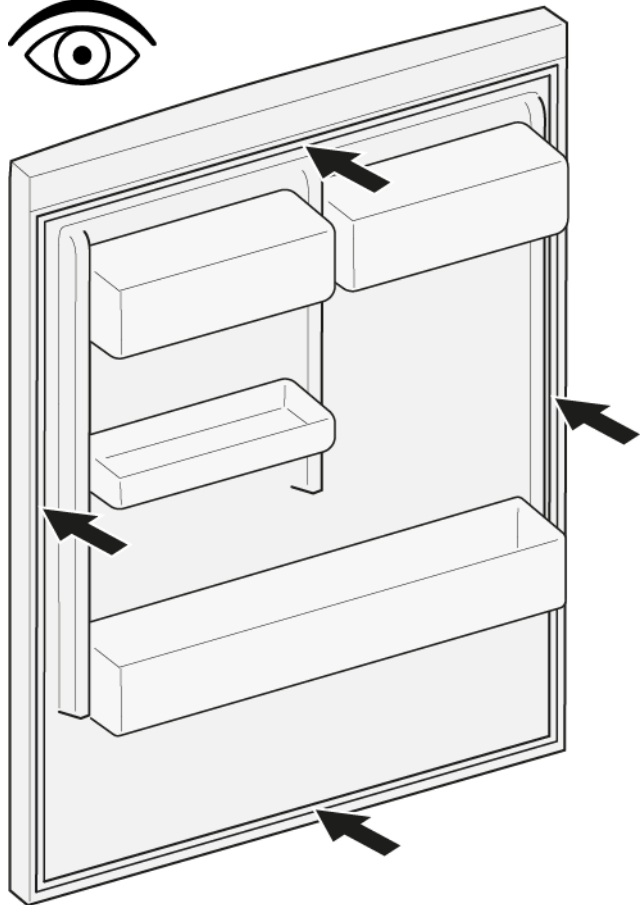

4. Wcisnąć narożniki uszczelki do rowka u dołu i u góry.

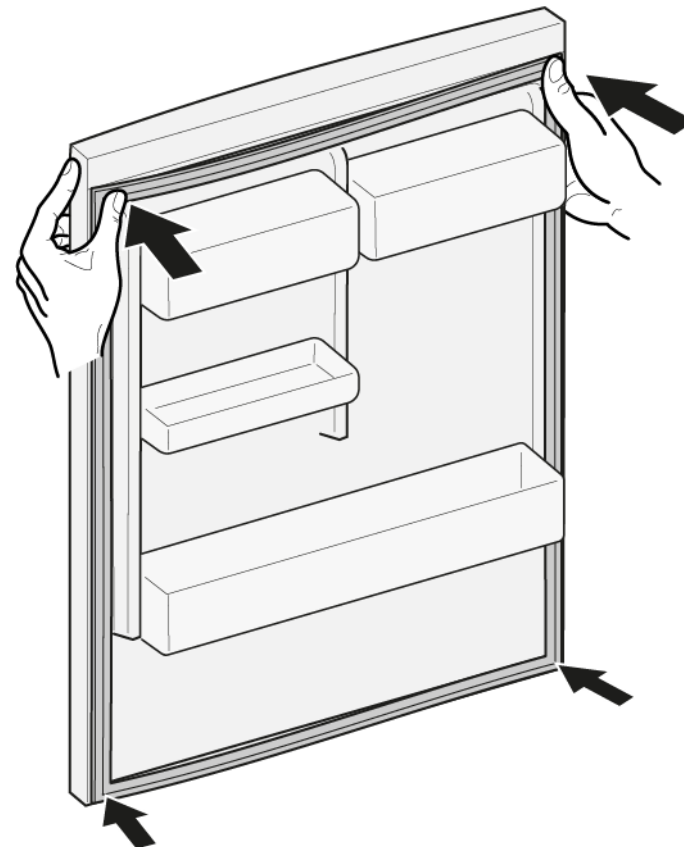

2.  Jeżeli rowek uszczelki jest uszkodzony.
- Skontaktować się z serwisem.

3.  Lekka deformacja uszczelki drzwiczek jest normalna i nie wpływa na jej funkcję. Zaleca się wyprostowanie uszczelki drzwiczek przed jej zamocowaniem w urządzeniu.

Ogrzać uszczelkę drzwiczek suszarką do włosów lub nadać jej żądany kształt rękami.

Naprawy

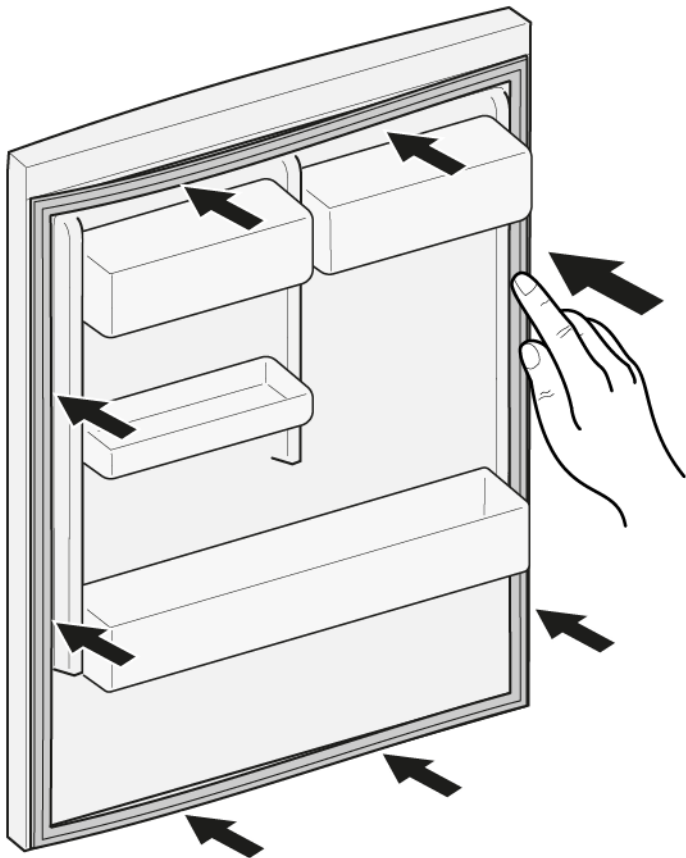

5. Krok po kroku wcisnąć uszczelkę do rowka na całym obwodzie.





 Uszczelka drzwiczek została zamontowana.

4.2 Wymiana uchwyty drzwiczek

Pomoce specjalne

-  Torx Bit TX20 6,3 mm (1/4") [00340865]
-  Śrubokręt z końcówką płaską Końcówka 10 mm x 1,6 mm x 200 mm

Warunek:

-  Urządzenie jest odłączone od źródła zasilania energią elektryczną.
-  Drzwiczki są otwarte.

4.2.1 Demontaż uchwyty drzwiczek

- ▶ 1. Wykręcić dwie zaślepki gwintowane (1).
- ▶ 2. Wykręcić dwie śruby (2).
- ▶ 3. Zdjąć uchwyt drzwiczek (3).

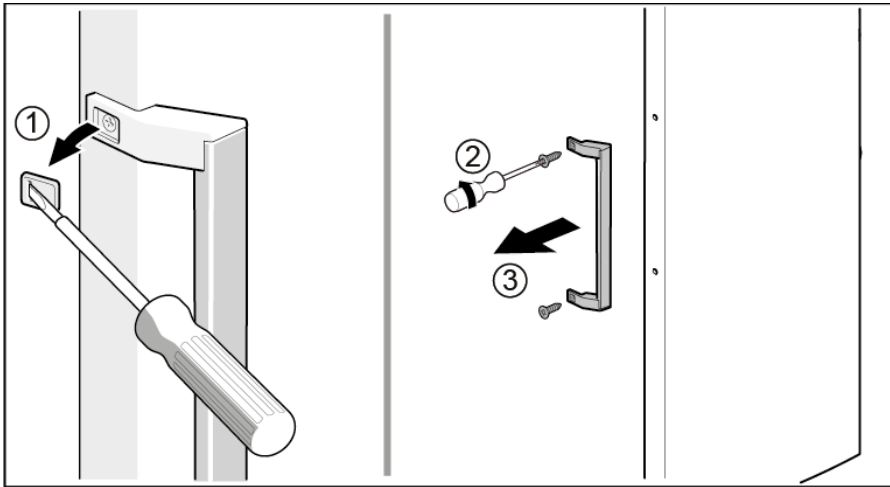

 Uchwyt drzwiczek został zdemontowany.



Uchwyt drugich drzwiczek można zdemontować w taki sam sposób.

4.2.2 Montaż uchwyty drzwiczek

- ▶ Montaż w odwrotnej kolejności.

4.3 Wymiana górnego zawiasu drzwiczek

Pomoce specjalne

Torx Bit TX20

6,3 mm (1/4")

[00340865]



OSTRZEŻENIE

Ciężkie, nieporęczne urządzenia!

Kontuzje mięśni i pleców

- ▶ Czynność demontażu drzwiczek urządzenia powinna być wykonywana tylko przez wyszkolonych techników.
- ▶ Przemieszczenie urządzenia wymaga udziału dwóch osób.
- ▶ Używać tylko odpowiednich narzędzi i sprzętu.



WAŻNE

Ostre krawędzie!

Rany cięte

- ▶ Zawsze używaj rękawic ochronnych.



OSTRZEŻENIE

Możliwość wyslizgnięcia się przechylnego urządzenia!

Złamania kości / zmiżdżenia

- ▶ Zabezpieczyć urządzenia przed wyslizgnięciem.



WAŻNE

Niebezpieczeństwo spadnięcia części po wykręceniu śrub!

Zranienie przez spadające części.

- ▶ Zabezpieczyć część przed spadnięciem.



UWAGA!

Niebezpieczeństwo spadnięcia części po wykręceniu śrub!

Uszkodzenie innych części urządzenia albo pomieszczenia mieszkalnego, np. podłogi.

- ▶ Zabezpieczyć część przed spadnięciem.

Warunek:

- ✔ Urządzenie jest odłączone od źródła zasilania energią elektryczną.
- ✔ Zostały zdemontowane wewnętrzne elementy mocujące urządzenia.

4.3.1 Demontaż górnego zawiasu drzwiczek

1. Wsunąć podpórkę pod podstawę.

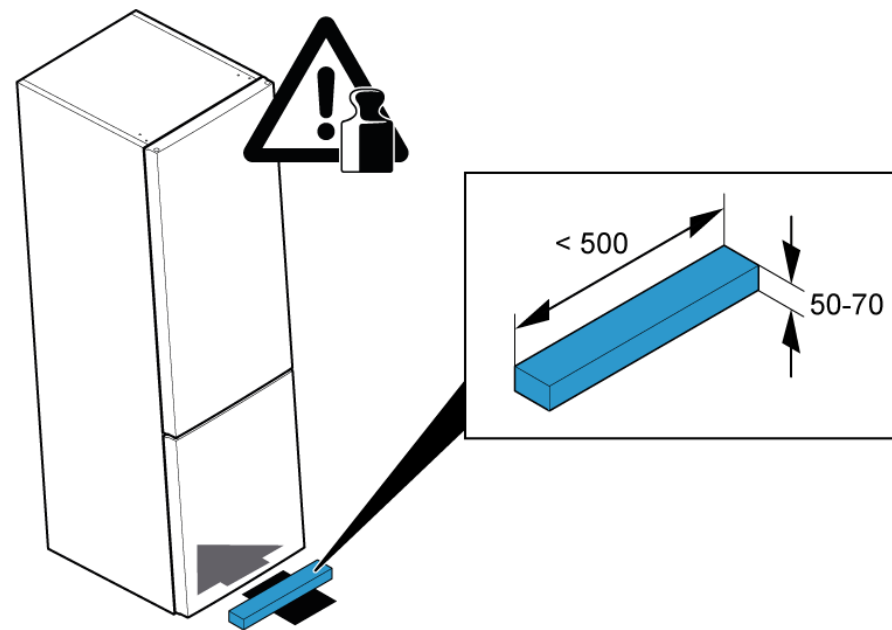

2. 1. Zdjąć osłonę zawiasu górnego (1).
2. Wykręcić dwie śruby (2).
3. Wyjąć zawias górny (3).

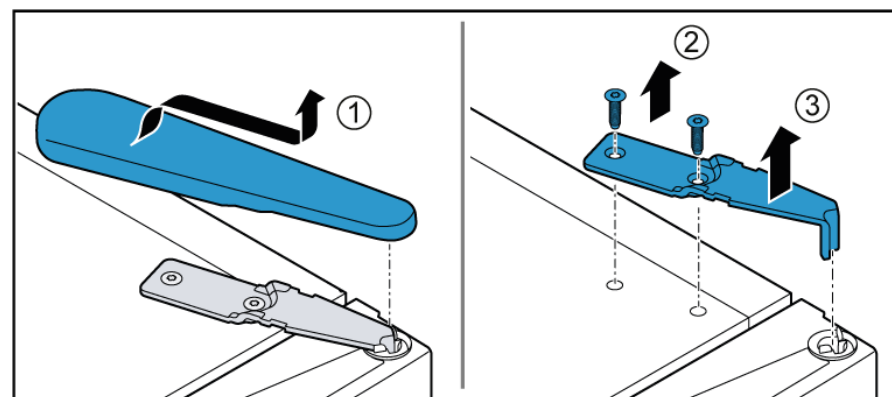

3. Wyjąć drzwiczki górne.

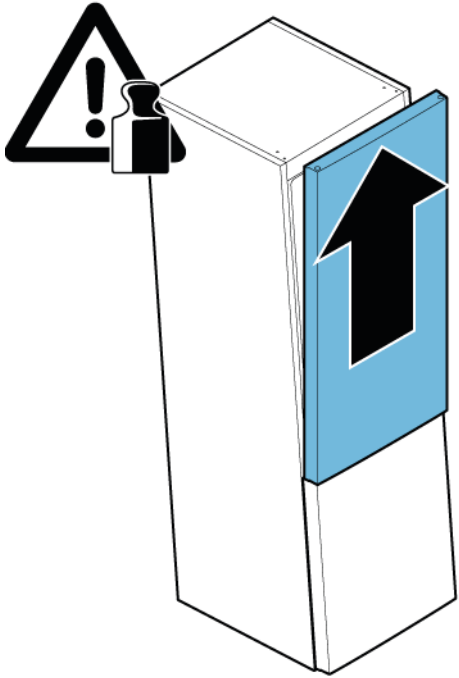

➡ Górny zawias jest zdemontowany.

4.3.2 Montaż górnego zawiasu drzwiczek

▶ Montaż w odwrotnej kolejności.

4.4 Wymiana górnego zawiasu drzwiczek (drzwiczki z wyświetlaczem)

Pomoce specjalne

 Torx Bit TX20 6,3 mm (1/4") [00340865]

	⚠ OSTRZEŻENIE
	<p>Ciężkie, nieporęczne urządzenia! Kontuzje mięśni i pleców</p> <ul style="list-style-type: none"> ▶ Czynność demontażu drzwiczek urządzenia powinna być wykonywana tylko przez wyszkolonych techników. ▶ Przemieszczenie urządzenia wymaga udziału dwóch osób. ▶ Używać tylko odpowiednich narzędzi i sprzętu.

	⚠ WAŻNE
	<p>Ostre krawędzie! Rany cięte</p> <ul style="list-style-type: none"> ▶ Zawsze używaj rękawic ochronnych.

	⚠ OSTRZEŻENIE
	<p>Możliwość wyslizgnięcia się przechylonego urządzenia! Złamania kości / zmiążdżenia</p> <ul style="list-style-type: none"> ▶ Zabezpieczyć urządzenia przed wyslizgnięciem.



	⚠ WAŻNE
	<p>Niebezpieczeństwo spadnięcia części po wykręceniu śrub! Zranienie przez spadające części.</p> <ul style="list-style-type: none"> ▶ Zabezpieczyć część przed spadnięciem.

	UWAGA!
	<p>Niebezpieczeństwo spadnięcia części po wykręceniu śrub! Uszkodzenie innych części urządzenia albo pomieszczenia mieszkalnego, np. podłogi.</p> <ul style="list-style-type: none"> ▶ Zabezpieczyć część przed spadnięciem.

	⚠ NIEBEZPIECZEŃSTWO
	<p>Ryzyko porażenia prądem elektrycznym wskutek kontaktu z elementami znajdującymi się pod napięciem! Niebezpieczeństwo utraty życia wskutek porażenia prądem elektrycznym w przypadku nieprawidłowej naprawy</p> <ul style="list-style-type: none"> ▶ Części elektryczne powinny być naprawiane przez wykwalifikowanych elektryków. ▶ Po naprawie należy przeprowadzić test bezpieczeństwa zgodny z przepisami normy VDE 0701 (Niemcy) lub odpowiednimi przepisami obowiązującymi w kraju użytkowania.

	⚠ NIEBEZPIECZEŃSTWO
	<p>Ryzyko porażenia prądem, ze względu na elementy będące pod napięciem! Zagrożenie życia poprzez porażenie prądem</p> <ul style="list-style-type: none"> ▶ Odłączyć urządzenie od zasilania sieciowego na 60 sekund przed rozpoczęciem naprawy.

Warunek:

-  Urządzenie jest odłączone od źródła zasilania energią elektryczną.
-  Zostały zdemontowane wewnętrzne elementy mocujące urządzenia.

4.4.1 Demontaż górnego zawiasu drzwiczek

1. Wsunąć podpórkę pod podstawę.

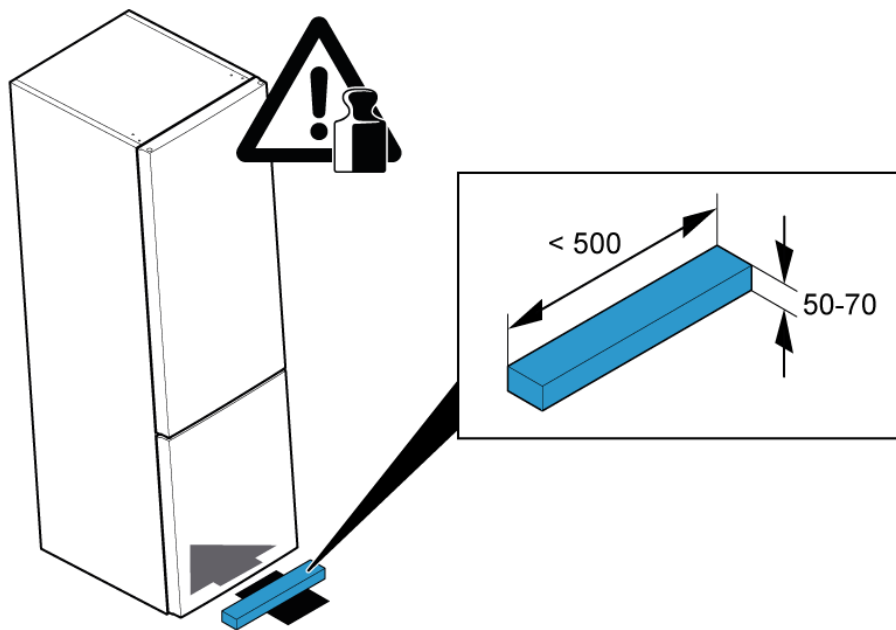

2. 1. Zdjąć osłonę zawiasu górnego (1).
2. Odłączyć złącze elektryczne (2).
3. Odkręcić śrubę złącza uziemienia (3).

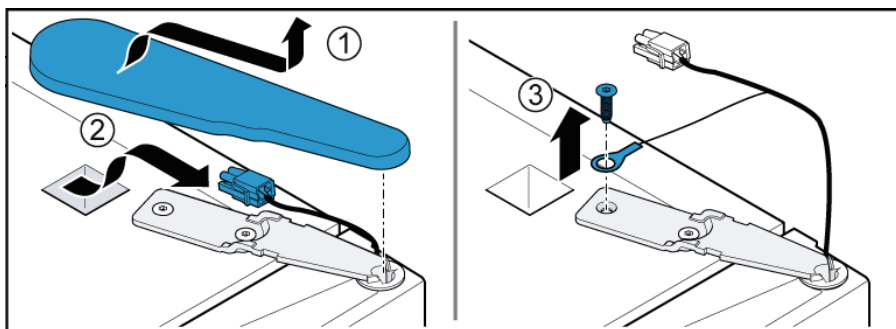

3. 1. Odkręcić śrubę (1).
2. Wyjąć zawias górny (2).

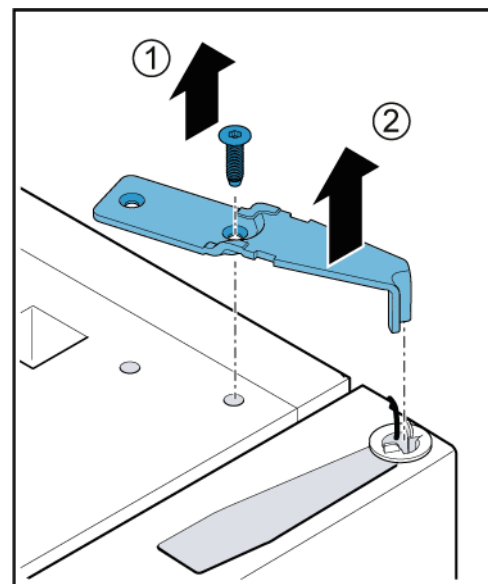

4. Wyjąć drzwiczki górne.

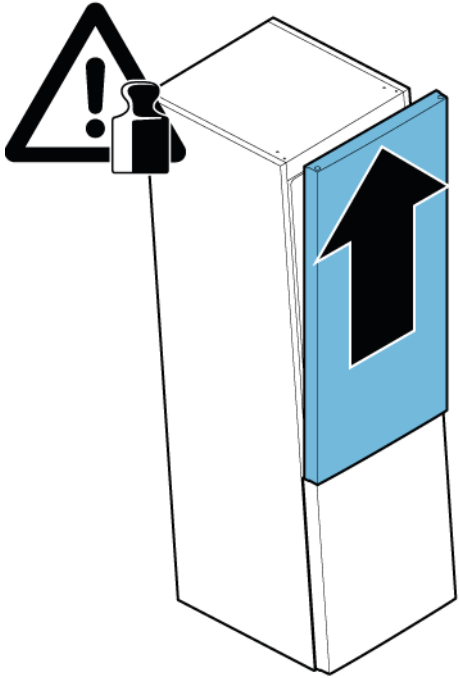

➡ Górny zawias jest zdemontowany.

4.4.2 Montaż górnego zawiasu drzwiczek

- ▶ Montaż w odwrotnej kolejności.

4.5 Wymiana środkowego zawiasu drzwiczek

Pomoce specjalne

Torx Bit TX20 6,3 mm (1/4") [00340865]

	⚠ OSTRZEŻENIE
	<p>Ciężkie, nieporęczne urządzenia! Kontuzje mięśni i pleców</p> <ul style="list-style-type: none"> ▶ Czynność demontażu drzwiczek urządzenia powinna być wykonywana tylko przez wyszkolonych techników. ▶ Przemieszczenie urządzenia wymaga udziału dwóch osób. ▶ Używać tylko odpowiednich narzędzi i sprzętu.

	⚠ WAŻNE
	<p>Ostre krawędzie! Rany cięte</p> <ul style="list-style-type: none"> ▶ Zawsze używaj rękawic ochronnych.

	⚠ OSTRZEŻENIE
	<p>Możliwość wyslizgnięcia się przechylnego urządzenia! Złamania kości / zmiżdżenia</p> <ul style="list-style-type: none"> ▶ Zabezpieczyć urządzenia przed wyslizgnięciem.

	⚠ WAŻNE
	<p>Niebezpieczeństwo spadnięcia części po wykręceniu śrub! Zranienie przez spadające części.</p> <ul style="list-style-type: none"> ▶ Zabezpieczyć część przed spadnięciem.

	UWAGA!
	<p>Niebezpieczeństwo spadnięcia części po wykręceniu śrub! Uszkodzenie innych części urządzenia albo pomieszczenia mieszkalnego, np. podłogi.</p> <ul style="list-style-type: none"> ▶ Zabezpieczyć część przed spadnięciem.

Warunek:

- ✓ Urządzenie jest odłączone od źródła zasilania energią elektryczną.
- ✓ Zostały zdemontowane wewnętrzne elementy mocujące urządzenia.
- ✓ Górny zawias drzwiczek jest zdemontowany.

✓ Górne drzwiczki są zdemontowane.

4.5.1 Demontaż środkowego zawiasu drzwiczek

1. 1. Wykręcić dwie śruby (1).
2. 2. Wyjąć środkowy zawias (2).

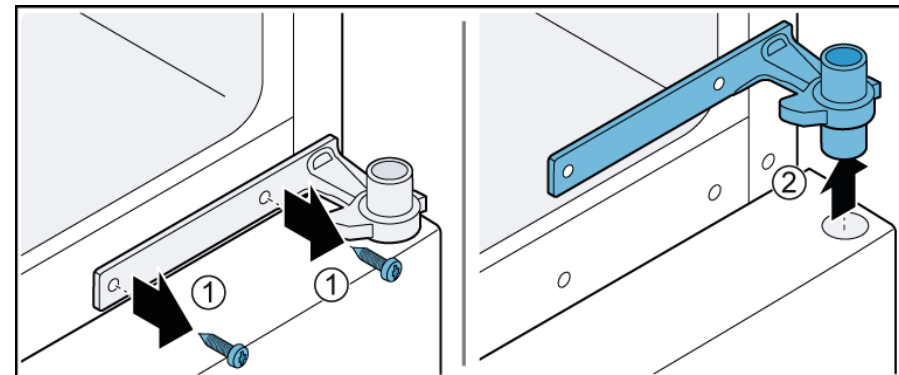

2. Wyjąć drzwiczki dolne.

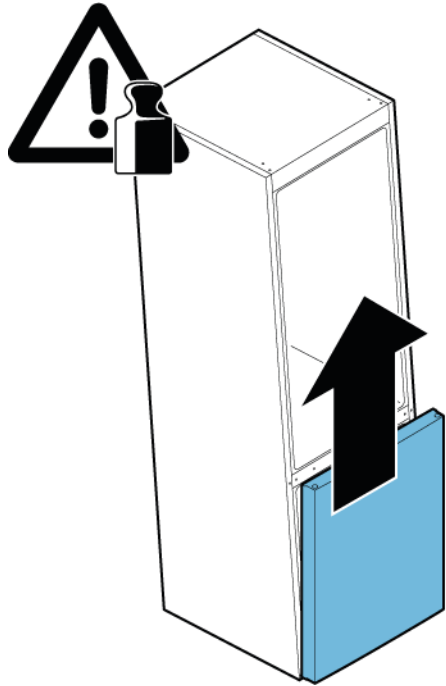

➡ Środkowy zawias jest zdemontowany.

4.5.2 Montaż środkowego zawiasu drzwiczek

- ▶ Montaż w odwrotnej kolejności.

4.6 Wymiana dolnego zawiasu drzwiczek

Pomoce specjalne

Torx Bit TX20 6,3 mm (1/4") [00340865]

	⚠ OSTRZEŻENIE
	<p>Ciężkie, nieporęczne urządzenia! Kontuzje mięśni i pleców</p> <ul style="list-style-type: none"> ▶ Czynność demontażu drzwiczek urządzenia powinna być wykonywana tylko przez wyszkolonych techników. ▶ Przemieszczenie urządzenia wymaga udziału dwóch osób. ▶ Używać tylko odpowiednich narzędzi i sprzętu.

	⚠ WAŻNE
	<p>Ostre krawędzie! Rany cięte</p> <ul style="list-style-type: none"> ▶ Zawsze używaj rękawic ochronnych.

	⚠ OSTRZEŻENIE
	<p>Możliwość wyslizgnięcia się przechylonego urządzenia! Złamania kości / zmiżdżenia</p> <ul style="list-style-type: none"> ▶ Zabezpieczyć urządzenia przed wyslizgnięciem.

	⚠ WAŻNE
	<p>Niebezpieczeństwo spadnięcia części po wykręceniu śrub! Zranienie przez spadające części.</p> <ul style="list-style-type: none"> ▶ Zabezpieczyć część przed spadnięciem.

	UWAGA!
	<p>Niebezpieczeństwo spadnięcia części po wykręceniu śrub! Uszkodzenie innych części urządzenia albo pomieszczenia mieszkalnego, np. podłogi.</p> <ul style="list-style-type: none"> ▶ Zabezpieczyć część przed spadnięciem.

Warunek:

- ✔ Urządzenie jest odłączone od źródła zasilania energią elektryczną.
- ✔ Zostały zdemontowane wewnętrzne elementy mocujące urządzenia.
- ✔ Górny zawias jest zdemontowany.

✔ Środkowy zawias jest zdemontowany.

4.6.1 Demontaż dolnego zawiasu drzwiczek

- ▶ 1. Wykręcić dwie śruby (1).
- ▶ 2. Wyjąć zawias dolny (2).

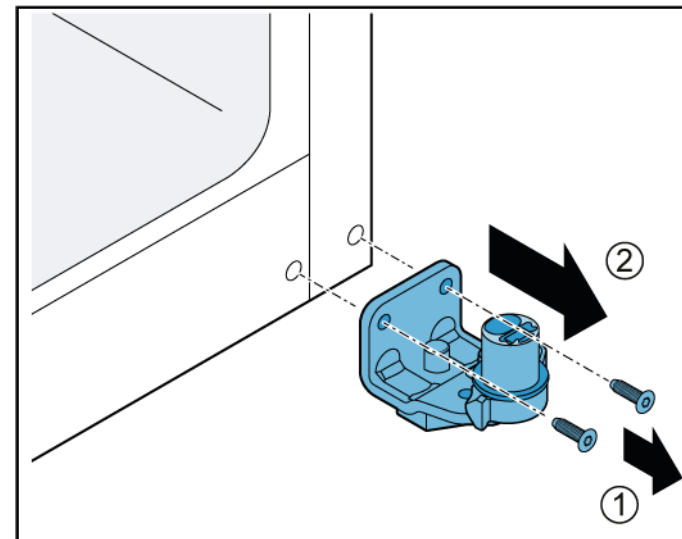

➡ Dolny zawias drzwiczek jest zdemontowany.

4.6.2 Montaż dolnego zawiasu drzwiczek

- ▶ Montaż w odwrotnej kolejności.

4.7 Wymiana półki

Warunek:

- ✔ Drzwiczki są otwarte.

4.7.1 Demontaż półki

- ▶ 1. Podnieść półkę z tyłu (1).
- ▶ 2. Zwolnić półkę (2).

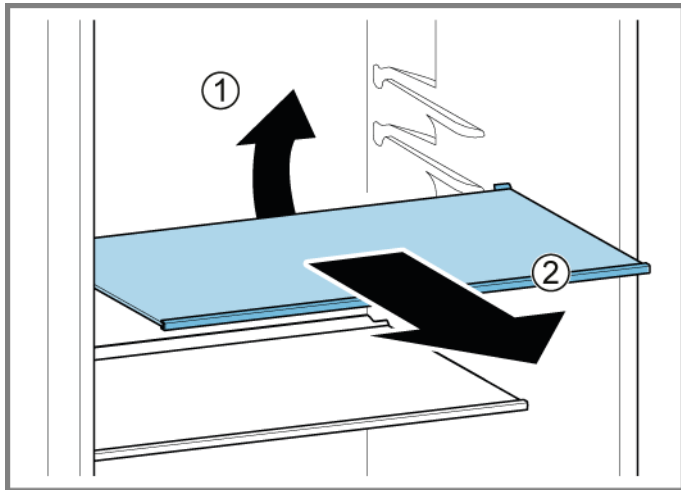

➡ Półka jest wyjęta.

4.7.2 Montaż półki

- ▶ Montaż w odwrotnej kolejności.

4.8 Wymiana podstawki na butelki

Warunek:

- ✔ Drzwiczki są otwarte.

4.8.1 Demontaż podstawki na butelki

- ▶ Wyciągnąć podstawkę na butelki.

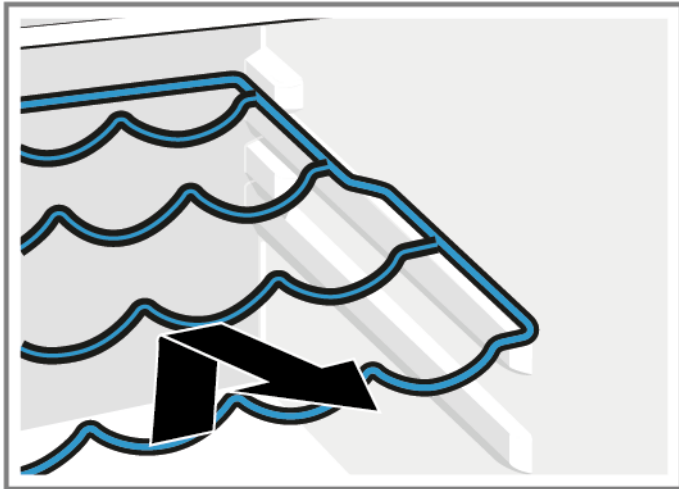

- ➡ Podstawka na butelki jest wyjęta.

4.8.2 Montaż podstawki na butelki

- ▶ Montaż w odwrotnej kolejności.

4.9 Wymiana półki drzwiczek

Warunek:

- ✔ Drzwiczki są otwarte.

4.9.1 Demontaż półki drzwiczek

- ▶ Podnieść półkę drzwiczek do góry.

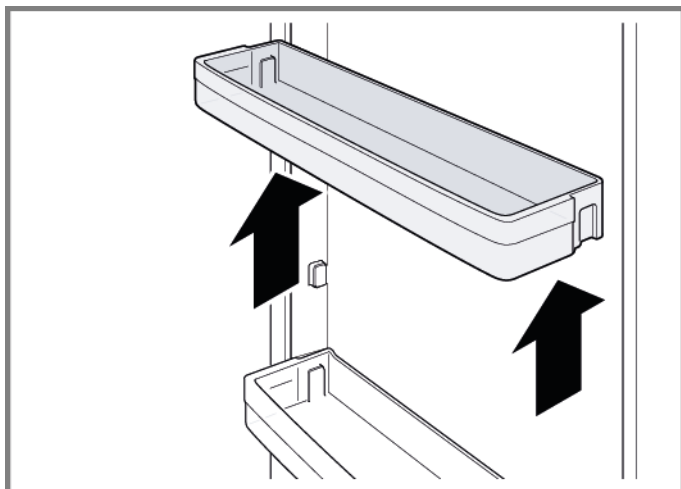

- ➡ Półka drzwiczek została zdemontowana.

4.9.2 Montaż półki drzwiczek

- ▶ Montaż w odwrotnej kolejności.

4.10 Wymiana pojemnika do przechowywania

Warunek:

- ✔ Drzwiczki są otwarte.

4.10.1 Demontaż pojemnika do przechowywania

1. Wyciągnąć pojemnik do przechowywania do oporu.
2. 1. Podnieść pojemnik do przechowywania z przodu (1).
2. Wyjąć pojemnik (2).

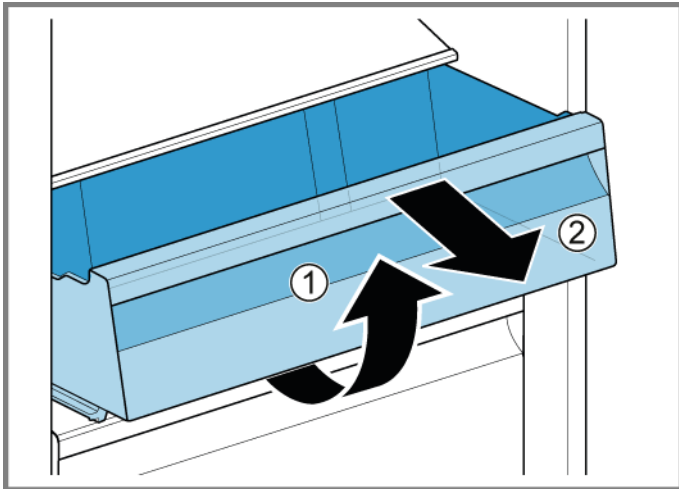

- ➔ Pojemnik do przechowywania został wyjęty.

4.10.2 Montaż pojemnika do przechowywania

- ▶ Montaż w odwrotnej kolejności.

4.11 Wymiana pojemnika na owoce i warzywa

Warunek:

- ✔ Drzwiczki są otwarte.

4.11.1 Demontaż pojemnika na owoce i warzywa

1. Wyciągnąć pojemnik na owoce i warzywa do oporu.
2. 1. Podnieść pojemnik na owoce i warzywa z przodu (1).
2. Wyjąć pojemnik (2).

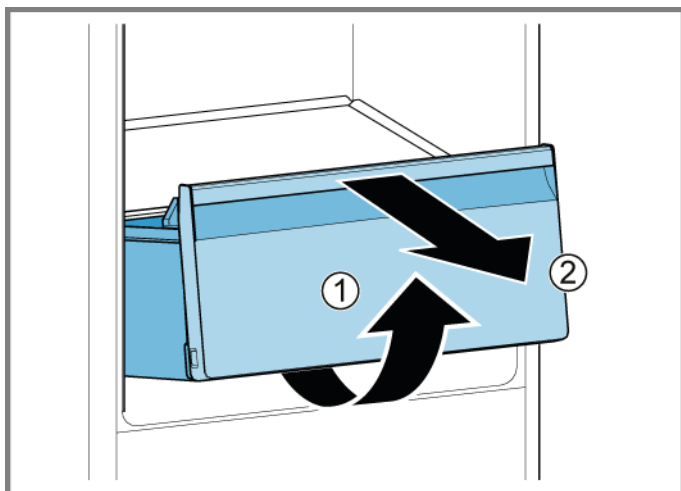

- ➡ Pojemnik na owoce i warzywa jest wyjęty.

4.11.2 Montaż pojemnika na owoce i warzywa

- ▶ Montaż w odwrotnej kolejności.

4.12 Wymiana półki nad pojemnikiem na owoce i warzywa

Warunek:

- ✔ Drzwiczki są otwarte.
- ✔ [Pojemnik na owoce i warzywa jest wyjęty. →497](#)

4.12.1 Demontaż półki nad pojemnikiem na owoce i warzywa

1. Popchnąć ramę uszczelniającą do góry i wypchnąć ją.

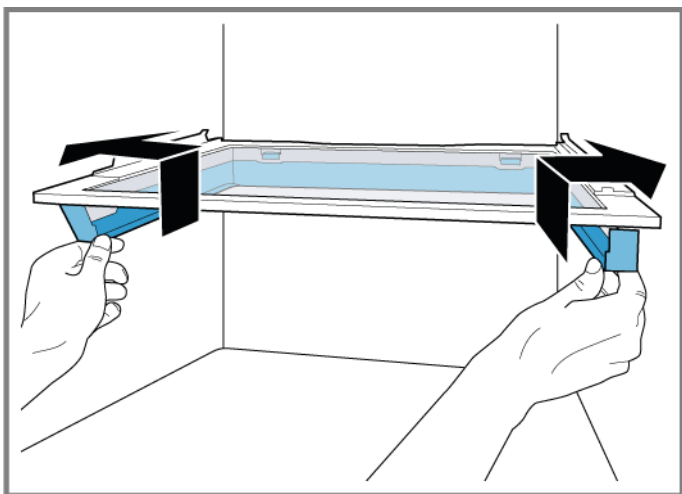

➡ Boczne zaczepy są zwolnione.

2. Podnieść ramę uszczelniającą i przesunąć ją do tyłu.

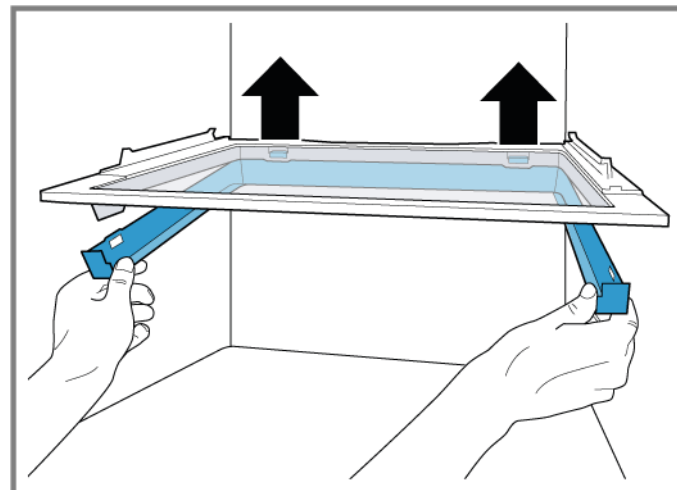

➡ Tylne zaczepy są zwolnione.

3. Zdemontować ramę pokrywy.
4. Podnieść półkę znajdującą się nad pojemnikiem na owoce i warzywa obracając wyjąć ją z boku.

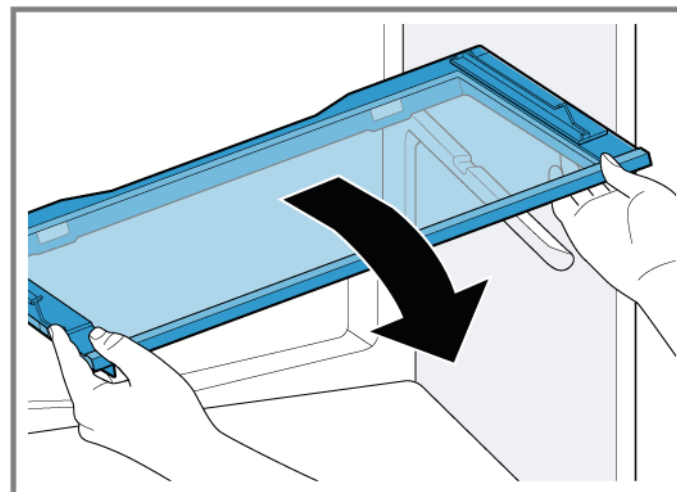

➡ Półka nad pojemnikiem na owoce i warzywa jest wyjęta.

4.12.2 Montaż półki nad pojemnikiem na owoce i warzywa

- ▶ Montaż w odwrotnej kolejności.

4.13 Wymiana pojemnika na mrożoną żywność

Warunek:

- ✔ Drzwiczki są otwarte.

4.13.1 Demontaż pojemnika na mrożoną żywność

- ▶ 1. Wyciągnąć pojemnik na mrożoną żywność do końca (1).
- ▶ 2. Wyjąć pojemnik na żywność (2).

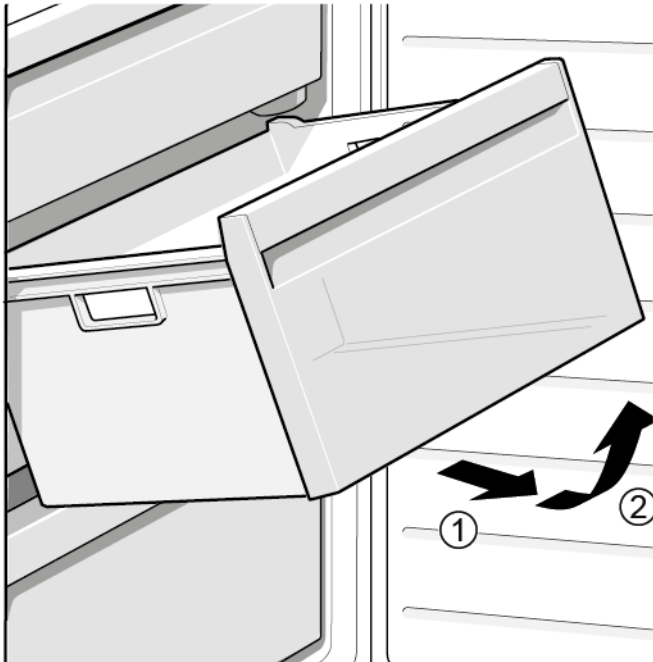

- ➡ Pojemnik na mrożoną żywność został wyjęty.

4.13.2 Montaż pojemnika na mrożoną żywność

- ▶ Montaż w odwrotnej kolejności.

4.14 Wymiana górnej żarówki LED

Pomoce specjalne

 Narzędzie specjalne

[00342180]



Urządzenie posiada bezobsługowe oświetlenie LED.
Tego rodzaju elementy oświetleniowe mogą być naprawiane wyłącznie przez serwis lub autoryzowanych techników!



NIEBEZPIECZEŃSTWO

Ryzyko porażenia prądem elektrycznym wskutek kontaktu z elementami znajdującymi się pod napięciem!

Niebezpieczeństwo utraty życia wskutek porażenia prądem elektrycznym w przypadku nieprawidłowej naprawy

- ▶ Części elektryczne powinny być naprawiane przez wykwalifikowanych elektryków.
- ▶ Po naprawie należy przeprowadzić test bezpieczeństwa zgodny z przepisami normy VDE 0701 (Niemcy) lub odpowiednimi przepisami obowiązującymi w kraju użytkowania.



NIEBEZPIECZEŃSTWO

Ryzyko porażenia prądem, ze względu na elementy będące pod napięciem!

Zagrożenie życia poprzez porażenie prądem

- ▶ Odłączyć urządzenie od zasilania sieciowego na 60 sekund przed rozpoczęciem naprawy.





WAŻNE

Ostre krawędzie!

Rany cięte

- ▶ Zawsze używaj rękawic ochronnych.

Warunek:

-  Urządzenie odłączone od źródła zasilania.
-  Drzwiczki są otwarte.

4.14.1 Demontaż górnej żarówki LED

1. 1. Wsunąć przyrząd demontażowy między górną żarówką LED i wewnętrzną wkładkę komory chłodziarki, aby zwolnić zaczepy żarówki (1).
2. Wyjąć górną żarówkę LED (2).

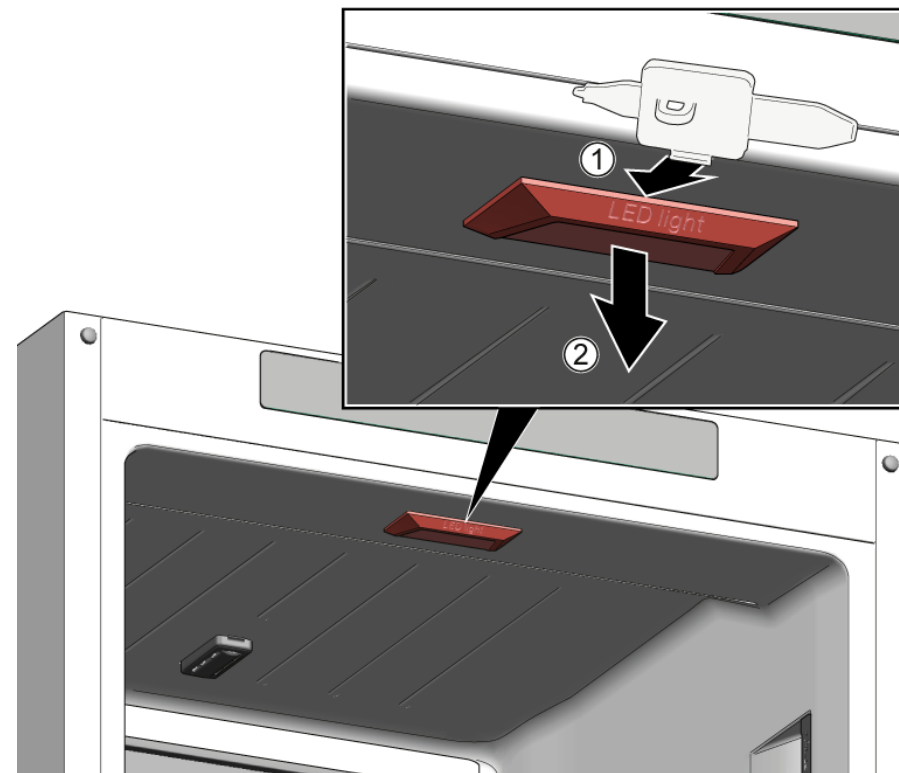

2. 2. Rozłączyć złącze elektryczne górnej żarówki LED.
-  Górna żarówka LED została wymontowana.

4.14.2 Montaż górnej żarówki LED

- ▶ Montaż w odwrotnej kolejności.



4.15 Wymiana bocznej żarówki LED



Pomoce specjalne



 Narzędzie specjalne

[00342180]

	<p>Urządzenie posiada bezobsługowe oświetlenie LED.</p> <p>Tego rodzaju elementy oświetleniowe mogą być naprawiane wyłącznie przez serwis lub autoryzowanych techników!</p>
---	---



	<p style="background-color: red; color: white; padding: 2px;"> NIEBEZPIECZEŃSTWO</p> <p>Ryzyko porażenia prądem elektrycznym wskutek kontaktu z elementami znajdującymi się pod napięciem!</p> <p>Niebezpieczeństwo utraty życia wskutek porażenia prądem elektrycznym w przypadku nieprawidłowej naprawy</p> <ul style="list-style-type: none"> ▶ Części elektryczne powinny być naprawiane przez wykwalifikowanych elektryków. ▶ Po naprawie należy przeprowadzić test bezpieczeństwa zgodny z przepisami normy VDE 0701 (Niemcy) lub odpowiednimi przepisami obowiązującymi w kraju użytkowania.
--	--

	<p style="background-color: red; color: white; padding: 2px;"> NIEBEZPIECZEŃSTWO</p> <p>Ryzyko porażenia prądem, ze względu na elementy będące pod napięciem!</p> <p>Zagrożenie życia poprzez porażenie prądem</p> <ul style="list-style-type: none"> ▶ Odłączyć urządzenie od zasilania sieciowego na 60 sekund przed rozpoczęciem naprawy.
--	--

	<p style="background-color: yellow; padding: 2px;"> WAŻNE</p> <p>Ostre krawędzie!</p> <p>Rany cięte</p> <ul style="list-style-type: none"> ▶ Zawsze używaj rękawic ochronnych.
--	--

	<p style="background-color: blue; color: white; padding: 2px;">UWAGA!</p> <p>Ryzyko uszkodzenia komponentów wrażliwych na wyładowania elektrostatyczne (ESD)!</p> <p>Uszkodzenie komponentów</p> <ul style="list-style-type: none"> ▶ Przed dotknięciem komponentów wrażliwych na wyładowania elektrostatyczne (ESD) podłączyć system ochrony elektrostatycznej (opaska z wtyczką uziemiającą). ▶ Nie dotykać połączeń i ścieżek przewodzących na modułach. ▶ Komponenty wrażliwe na wyładowania elektrostatyczne (ESD) transportować wyłącznie w materiałach przewodzących lub oryginalnym opakowaniu. ▶ Komponenty wrażliwe na wyładowania elektrostatyczne (ESD) trzymać z dala od materiałów ładujących się elektrostatycznie (np. plastik).
---	--

Warunek:

-  Urządzenie odłączone od źródła zasilania.
-  Drzwiczki są otwarte.
-  Zostały zdemonstrowane wewnętrzne elementy mocujące komory chłodziarki.

4.15.1 Demontaż bocznej żarówki LED

1. 1. Wsunąć przyrząd demontażowy między klosz lampy i obudowę, aby zwolnić zaczepy (1).
2. Wyjąć klosz lampy (2).
3. W ten sam sposób zwolnić kolejne zaczepy mocujące dyfuzor.

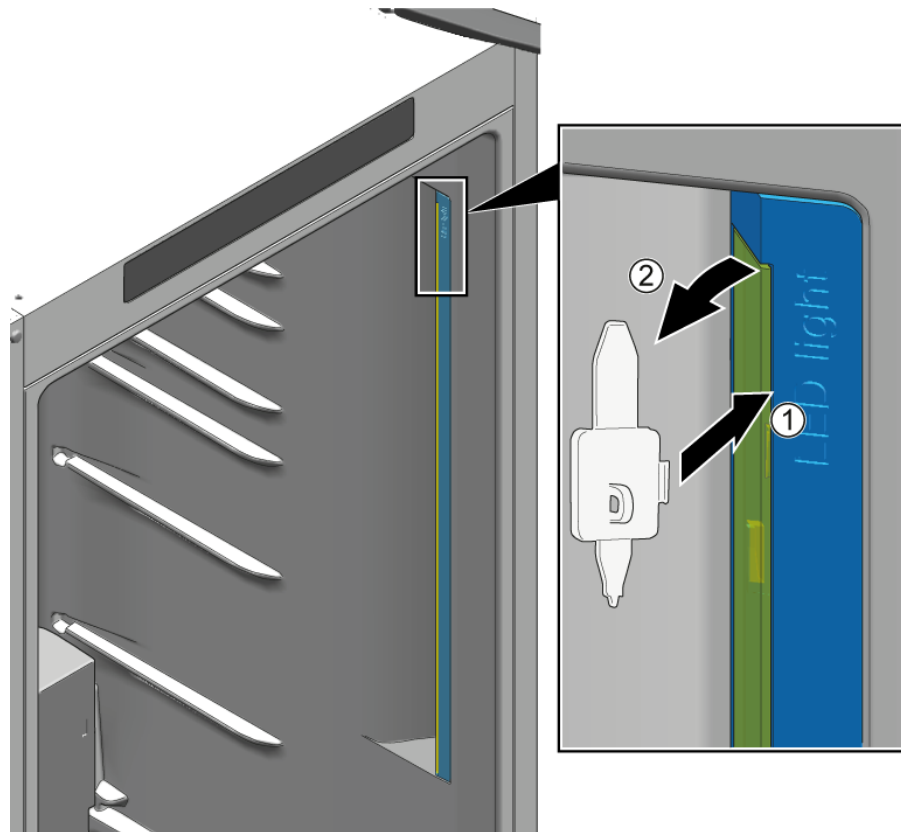

➡ Klosz lampy jest zdemontowany.

2. 1. Nacisnąć zaczepy mocujące, aby zwolnić (1).
2. Unieść moduł LED ok. 1 cm, aby odłączyć wtyczkę od gniazda (2).
3. Wyjąć moduł LED (3).

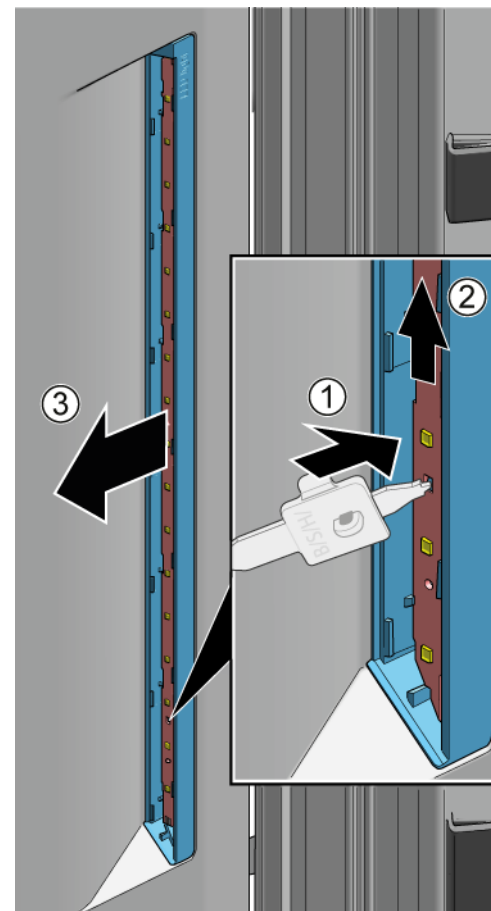

➡ Boczna żarówka LED została wymontowana.

4.15.2 Montaż bocznej żarówki LED



Ze względu na to, że zaczepy klosza lampy łatwo się łamią podczas wymiany, część zamienna: żarówka boczna LED, stanowi zestaw zawierający moduł LED i klosz lampy.

Naprawy

1. Wsunąć przyrząd demontażowy między klosz lampy i obudowę, aby zwolnić zaczepy (1).
2. Wyjąć klosz lampy (2).
3. W ten sam sposób zwolnić kolejne zaczepy mocujące dyfuzor.

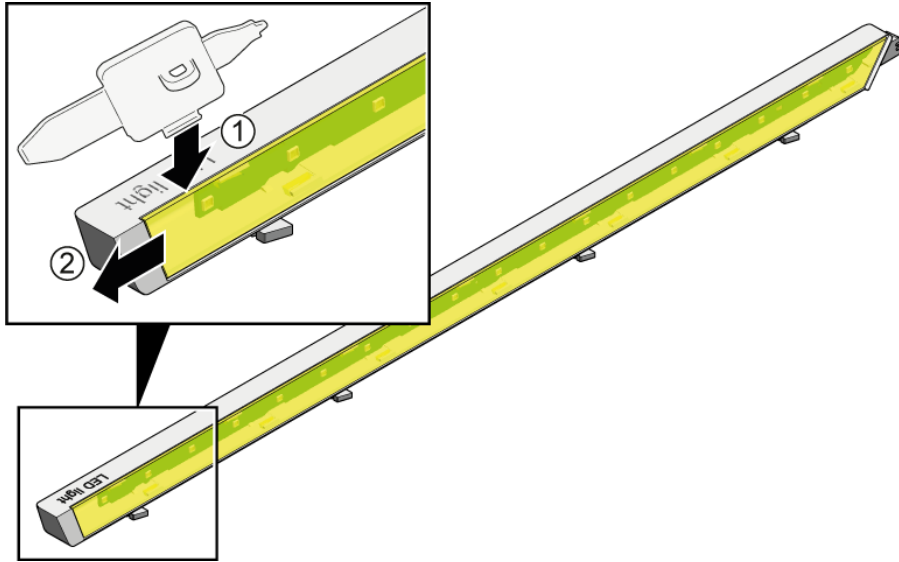

2. 1. Nacisnąć zaczepy mocujące, aby zwolnić (1).
2. Wysunąć moduł LED z obudowy.
3. Wyrzucić opakowanie modułu LED, które było użyte do transportu, ze względów bezpieczeństwa (3).

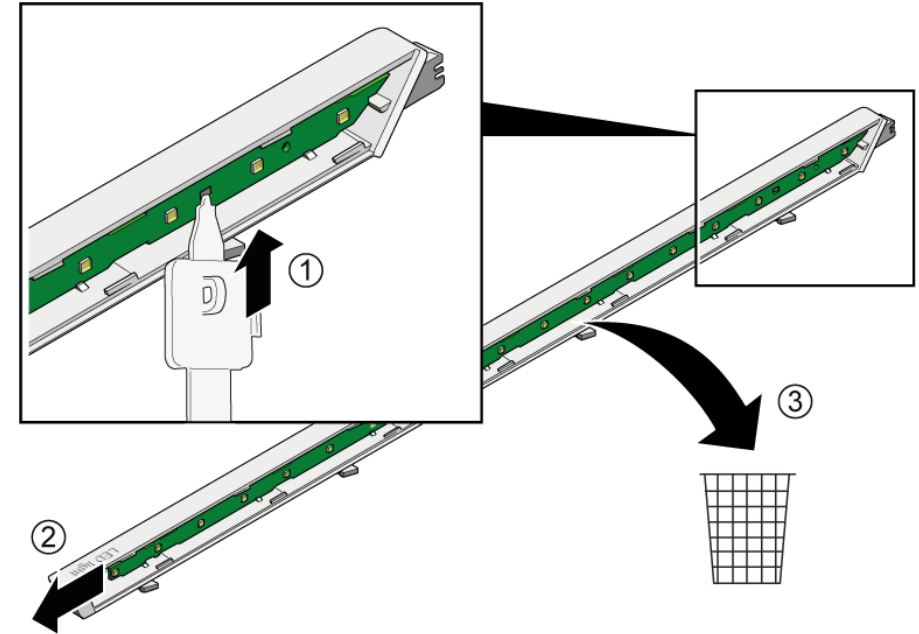

3. Montaż modułu LED i klosza w odwrotnej kolejności do demontażu.

4.16 Wymiana żarówki LED w zamrażarce

Pomoce specjalne

Narzędzie specjalne

[00342180]



Urządzenie posiada bezobsługowe oświetlenie LED.
Tego rodzaju elementy oświetleniowe mogą być naprawiane wyłącznie przez serwis lub autoryzowanych techników!



NIEBEZPIECZEŃSTWO

Ryzyko porażenia prądem elektrycznym wskutek kontaktu z elementami znajdującymi się pod napięciem!

Niebezpieczeństwo utraty życia wskutek porażenia prądem elektrycznym w przypadku nieprawidłowej naprawy

- ▶ Części elektryczne powinny być naprawiane przez wykwalifikowanych elektryków.
- ▶ Po naprawie należy przeprowadzić test bezpieczeństwa zgodny z przepisami normy VDE 0701 (Niemcy) lub odpowiednimi przepisami obowiązującymi w kraju użytkownika.



NIEBEZPIECZEŃSTWO

Ryzyko porażenia prądem, ze względu na elementy będące pod napięciem!

Zagrożenie życia poprzez porażenie prądem

- ▶ Odłączyć urządzenie od zasilania sieciowego na 60 sekund przed rozpoczęciem naprawy.



WAŻNE

Ostre krawędzie!

Rany cięte

- ▶ Zawsze używaj rękawic ochronnych.

Warunek:

- ✔ Urządzenie odłączone od źródła zasilania.
- ✔ Drzwiczki są otwarte.

4.16.1 Demontaż żarówki LED w zamrażarce

- ▶ 1. Wsunąć przyrząd demontażowy między żarówkę i obudowę po stronie żarówki, aby wytworzyć szczelinę (1).
- ▶ 2. Przesunąć przyrząd demontażowy na drugą stronę zaczepu mocującego żarówkę i obrócić go do przodu (2).
- ▶ 3. Wyjąć żarówkę LED zamrażarki (3).

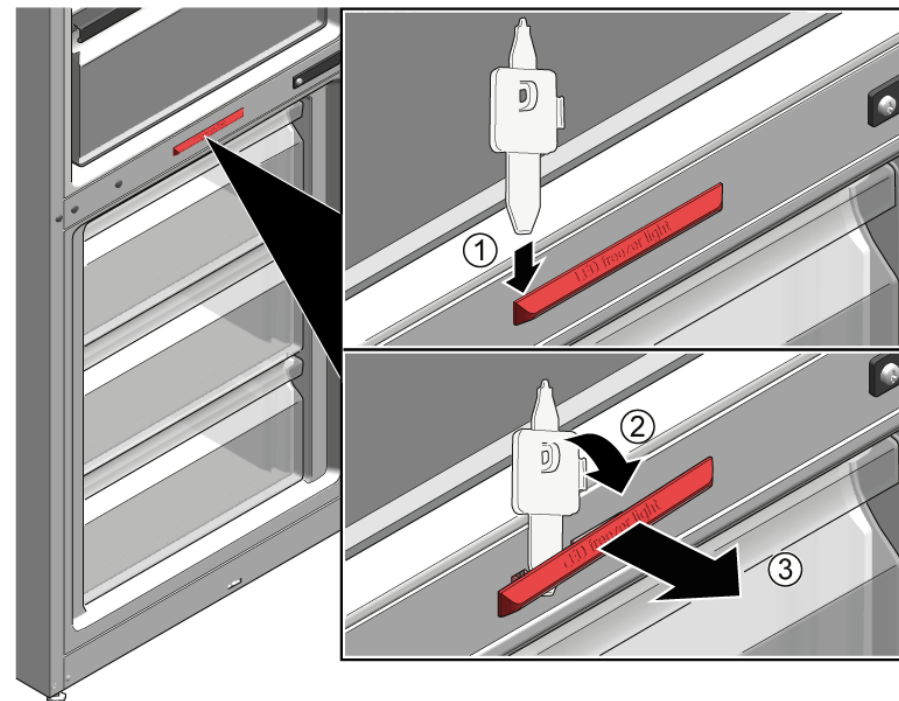





- ➡ Żarówka LED zamrażarki jest odłączona.
- ➡ Żarówka LED zamrażarki jest wymontowana.

4.16.2 Montaż żarówki LED w zamrażarce

- ▶ Montaż w odwrotnej kolejności.

Dicas de resolução - Combinado de refrigeração/congelação

 Sobre este documento	507
1.1 Informação importante	507
1.1.1 Finalidade.....	507
1.2 Explicação dos símbolos.....	507
1.2.1 Níveis de perigo.....	507
1.2.2 Símbolos de perigo	507
1.2.3 Estrutura dos avisos.....	508
1.2.4 Símbolos gerais	508
 Segurança	509
2.1 Instruções gerais de segurança.....	509
2.1.1 Todos os eletrodomésticos	509
 Ferramentas e auxiliares	510
 Reparação	511
4.1 Substituir a junta da porta	511
4.1.1 Remover a junta da porta	511
4.1.2 Instalar a junta da porta.....	511
4.2 Substituir o puxador da porta	514
4.2.1 Remover o puxador da porta	514
4.2.2 Instalar o puxador da porta	514
4.3 Substituir a dobradiça superior da porta.....	515
4.3.1 Remover a dobradiça superior da porta.....	515
4.3.2 Instalar a dobradiça superior da porta	516
4.4 Substituir a dobradiça superior da porta (porta com visor).....	517
4.4.1 Remover a dobradiça superior da porta.....	518
4.4.2 Instalar a dobradiça superior da porta	519
4.5 Substituir a dobradiça central da porta	520
4.5.1 Remover a dobradiça central da porta.....	520
4.5.2 Instalar a dobradiça central da porta	521
4.6 Substituir a dobradiça inferior da porta.....	522
4.6.1 Remover a dobradiça inferior da porta.....	522
4.6.2 Instalar a dobradiça inferior da porta	522
4.7 Substituir a prateleira	523
4.7.1 Remover a prateleira.....	523
4.7.2 Instalar a prateleira	523
4.8 Substituir o suporte para garrafas	524
4.8.1 Remover o suporte para garrafas	524
4.8.2 Instalar o suporte para garrafas.....	524
4.9 Substituir a prateleira da porta	525
4.9.1 Remover a prateleira da porta	525
4.9.2 Instalar a prateleira da porta.....	525
4.10 Substituir o recipiente de armazenamento	526
4.10.1 Remover o recipiente de armazenamento.....	526
4.10.2 Instalar o recipiente de armazenamento	526
4.11 Substituir o recipiente para fruta e vegetais	527
4.11.1 Remover o recipiente para fruta e vegetais	527
4.11.2 Instalar o recipiente para fruta e vegetais.....	527
4.12 Substituir a prateleira sobre o recipiente para fruta e vegetais	528
4.12.1 Remover a prateleira sobre o recipiente para fruta e vegetais	528
4.12.2 Instalar a prateleira por cima do recipiente para fruta e vegetais	529
4.13 Substituir o recipiente para alimentos congelados.....	530
4.13.1 Remover o recipiente para alimentos congelados.....	530
4.13.2 Instalar o recipiente para alimentos congelados	530
4.14 Substituir a lâmpada LED superior	531
4.14.1 Remover a lâmpada LED superior	531
4.14.2 Instalar a lâmpada LED superior	531
4.15 Substituir a lâmpada LED lateral	532
4.15.1 Remover a lâmpada LED lateral	533
4.15.2 Instalar a lâmpada LED lateral	533
4.16 Substituir a lâmpada LED do congelador.....	535
4.16.1 Remover a lâmpada LED do congelador.....	535
4.16.2 Instalar a lâmpada LED do congelador	535

i Sobre este documento

1.1 Informação importante

1.1.1 Finalidade

Estas dicas de reparação auxiliam o consumidor na reparação de aparelhos por ele próprio de acordo com o regulamento de "Eco-design" aplicável (a partir de 03/2021).

Estas contêm informações sobre como substituir peças sobressalentes definidas, incluindo avisos e riscos.

Em caso de dúvidas, entre em contacto com o nosso serviço de apoio ao cliente. Apenas nos responsabilizaremos por danos se as dicas de reparação tiverem sido devidamente seguidas.

1.2 Explicação dos símbolos

1.2.1 Níveis de perigo

Os níveis de aviso são compostos por um símbolo e uma palavra sinal. A palavra-sinal indica a gravidade do perigo.







Nível de aviso	Significado
	A não observância da mensagem de aviso resulta em morte ou ferimentos graves.
	A não observância da mensagem de aviso pode resultar em morte ou ferimentos graves.
	A não observância da mensagem de aviso pode resultar em ferimentos ligeiros.
	A não observância da mensagem de aviso pode resultar em danos materiais.

Tabela 1: Níveis de perigo

1.2.2 Símbolos de perigo

Os símbolos de perigo são representações simbólicas que dão uma indicação do tipo de perigo.

Neste documento são utilizados os seguintes símbolos de perigo:

Símbolo de perigo	Significado
	Mensagem geral de aviso
	Perigo de tensão elétrica
	Risco de explosão
	Perigo de cortes

i Sobre este documento





Símbolo de perigo	Significado
	Perigo de esmagamento
	Perigo de superfícies quentes
	Perigo de campo eletromagnético intenso
	Perigo de radiação não-ionizante

Tabela 2: Símbolos de perigo

1.2.3 Estrutura dos avisos

Os avisos neste documento possuem um aspeto normalizado e uma estrutura normalizada.

	<div style="background-color: red; color: white; padding: 2px; text-align: center;">⚠ PERIGO</div> <p>Tipo e origem do perigo! Possíveis consequência de ignorar o perigo / aviso.</p> <ul style="list-style-type: none"> ▶ Medidas e proibições para prevenir o perigo.
--	---

O seguinte exemplo mostra um aviso que adverte contra choques elétricos devido a partes sob tensão. A medida para evitar o perigo é mencionada.

	<div style="background-color: red; color: white; padding: 2px; text-align: center;">⚠ PERIGO</div> <p>Risco de choque elétrico devido a partes sob tensão! Morte por eletrocussão</p> <ul style="list-style-type: none"> ▶ Desligue os aparelhos da alimentação elétrica pelo menos 60 segundos antes de iniciar as reparações.
--	--

1.2.4 Símbolos gerais

Neste documento são utilizados os seguintes símbolos gerais:







Símbolo ger.	Significado
	Identificação de uma dica especial (texto e/ou ilustração)
	Identificação de uma dica simples (apenas texto)
	Identificação de uma ligação para um tutorial em vídeo
	Identificação das ferramentas necessárias
	Identificação das condições prévias necessárias
	Identificação de uma condição (se ..., então ...)
	Identificação de um resultado
Iniciar	Identificação de uma tecla ou botão
[00123456]	Identificação de um número de material
Estado	Identificação de um texto exibido / janela (no visor do aparelho)

Tabela 3: Símbolos gerais

2.1 Instruções gerais de segurança

2.1.1 Todos os eletrodomésticos

Risco de choque elétrico devido a partes sob tensão!

- Erros por reparações envolvendo componentes elétricos podem provocar choques elétricos!
- Desligue o aparelho da rede elétrica pelo menos 60 segundos antes de iniciar o trabalho.
- Após a reparação, solicite a realização de um teste de segurança de acordo com VDE 0701 ou os regulamentos específicos do país.

Risco de ferimentos causados por arestas vivas!

- Use luvas de proteção.

Risco de esmagamento durante trabalhos de reparação, manutenção, resolução de problemas e serviço devido a componentes pesados e móveis

- Use calçado de proteção.
- Proteja os componentes pesados contra quedas.
- Não introduzir partes do corpo em componentes móveis.

Risco para a segurança/funcionamento do aparelho!

- Utilize apenas peças sobressalentes originais.

Risco de danos em componentes electrostáticamente sensíveis (ESDs)!

- Não toque nos módulos, incluindo ligações e percursos condutores.

Ferramentas e auxiliares

Designação	Detalhes	Imagens
Ponta Torx TX20 [00340865]	6,3 mm (1/4")	
Ferramenta especial [00342180]		

4.1 Substituir a junta da porta

Pré-requisito:

- ✔ A porta está aberta.

4.1.1 Remover a junta da porta

1. Solte a junta da porta da ranhura nos cantos direito e esquerdo.

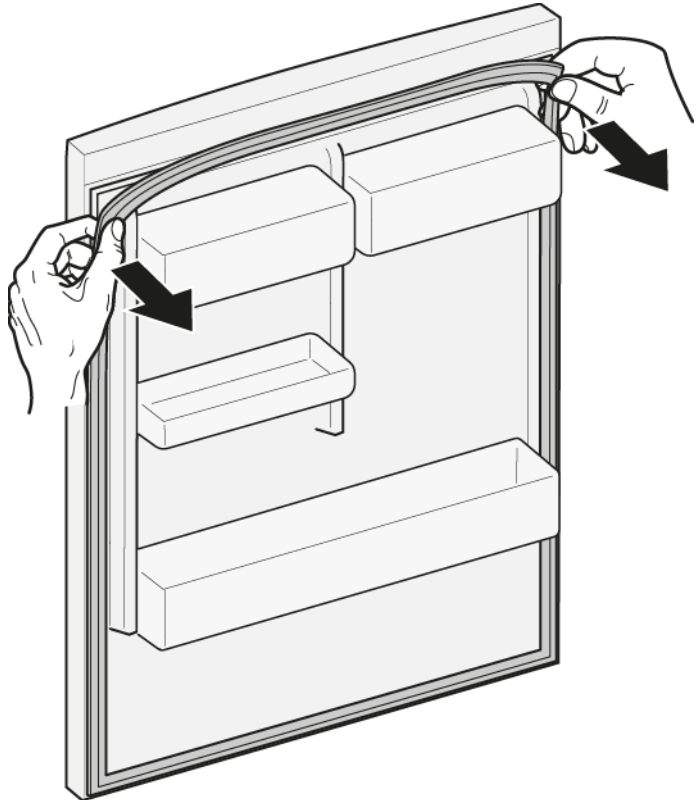

2. Puxe a junta da porta para fora da ranhura.

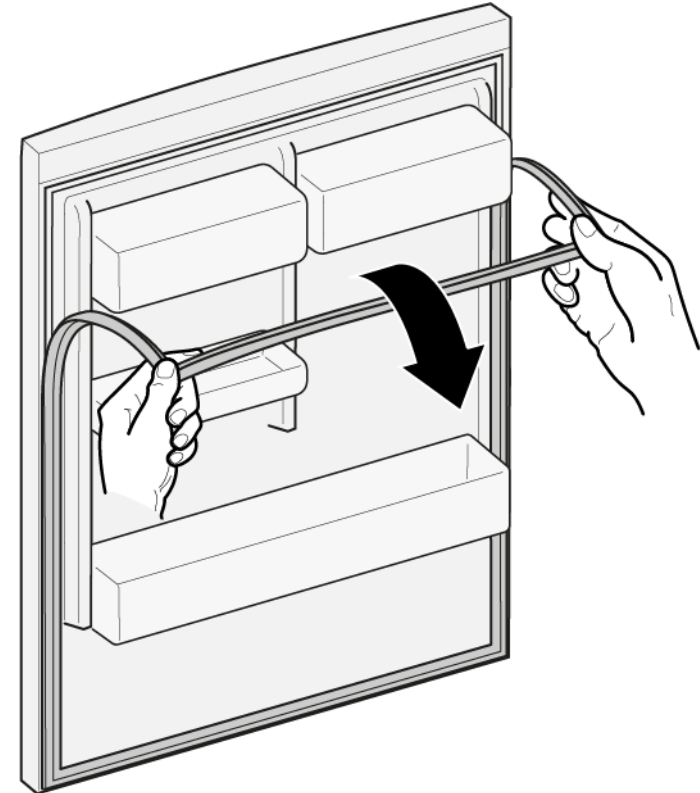

- ➡ A junta da porta está removida.

4.1.2 Instalar a junta da porta



A espessura da nova junta da porta pode divergir ligeiramente da da junta antiga da porta. Isto não afetará o comportamento de fecho nem o funcionamento a longo termo.

Se o seu aparelho dispor de dobradiças ou fixações de dobradiça ajustáveis, poderá otimizar o comportamento de fecho subseqüentemente.

Os pequenos orifícios laterais na junta da porta são funcionais (necessários à ventilação). Não se trata de falhas de produção.

Reparação

1. Verifique se a ranhura para a junta apresenta danos.

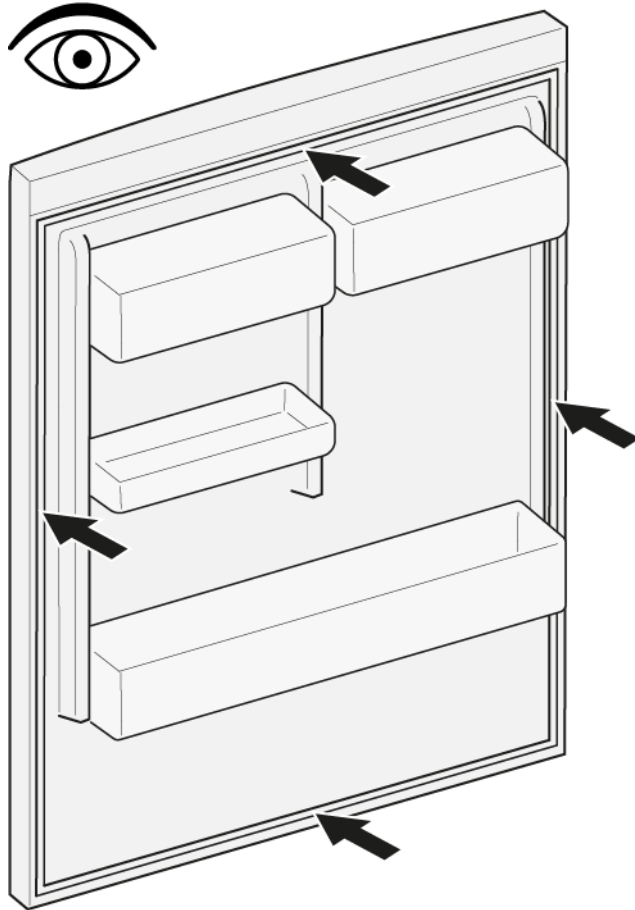

2.  Se a ranhura para a junta estiver danificada,
- contacte o serviço de apoio ao consumidor.

3.  Uma deformação ligeira da junta da porta é normal e não afeta o seu funcionamento. Recomenda-se que a junta da porta seja endireitada antes de ser inserida no aparelho.

Aqueça a junta da porta com a um secador de cabelo ou água quente e mude a sua forma manualmente.

4. Empurre os cantos da junta em cima e em baixo para ranhura.

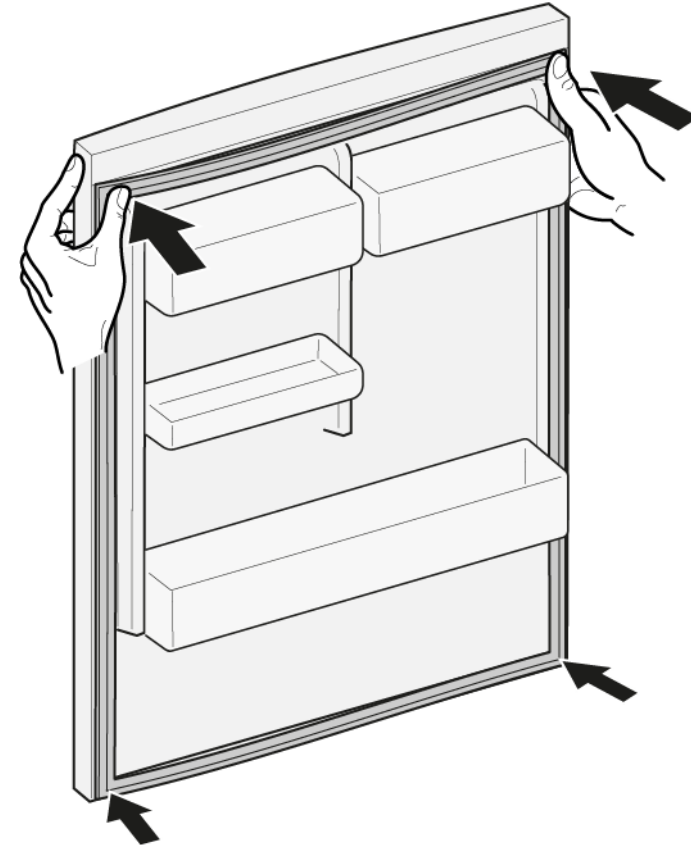

Reparação



5. Pressione a junta inteira gradualmente para dentro da ranhura.





-  A junta da porta está instalada.

4.2 Substituir o puxador da porta

Ferramentas necessárias:

-  Ponta Torx TX20 6,3 mm (1/4") [00340865]
-  Chave de fendas Lâmina 10 mm x 1,6 mm x 200 mm

Pré-requisito:

-  O aparelho está desligado da alimentação elétrica.
-  A porta está aberta.

4.2.1 Remover o puxador da porta

- ▶ 1. Remova duas tampas roscadas (1).
- ▶ 2. Desaperte dois parafusos (2).
- ▶ 3. Remova o puxador da porta (3).

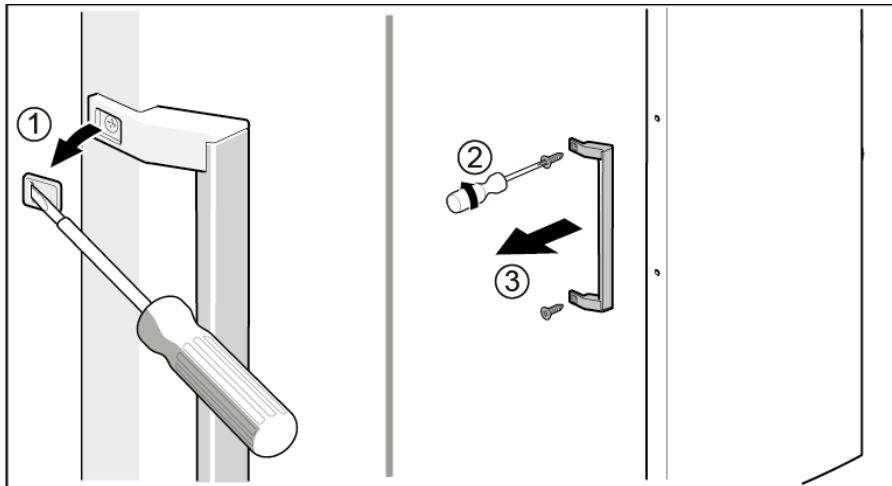

 O puxador da porta está removido.



O puxador da porta para a segunda porta pode ser removido da mesma forma.

4.2.2 Instalar o puxador da porta

- ▶ Instale pela ordem inversa.

4.3 Substituir a dobradiça superior da porta

Ferramentas necessárias:

🔧 Ponta Torx TX20 6,3 mm (1/4") [00340865]

	⚠️ AVISO
Aparelhos pesados e volumosos!	
Lesões nas costas e musculares	
<ul style="list-style-type: none"> ▶ A operação de remoção da porta do aparelho deve ser apenas executada por especialistas formados. ▶ São necessárias duas pessoas para mover o aparelho. ▶ Use apenas ferramentas e equipamento adequados. 	

	⚠️ CUIDADO
Arestas vivas!	
Lesões por corte	
<ul style="list-style-type: none"> ▶ Use luvas de proteção. 	

	⚠️ AVISO
Deslizamento de aparelhos inclinados!	
Fraturas ósseas / ferimentos de esmagamento	
<ul style="list-style-type: none"> ▶ Proteja os aparelhos contra o deslizamento. 	

	⚠️ CUIDADO
Risco de queda de peças devido a parafusos desapertados!	
Lesões devido à queda de peças.	
<ul style="list-style-type: none"> ▶ Proteja o componente contra as quedas. 	

	ATENÇÃO!
Risco de queda de peças devido a parafusos desapertados!	
Danos em outros componentes do aparelho ou na casa do cliente, p. ex., no pavimento.	
<ul style="list-style-type: none"> ▶ Proteja o componente contra as quedas. 	

Pré-requisito:

- ✔ O aparelho está desligado da alimentação elétrica.
- ✔ As fixações interiores do aparelho estão removidas.

4.3.1 Remover a dobradiça superior da porta

1. Deslize a peça de apoio por baixo da secção da base.

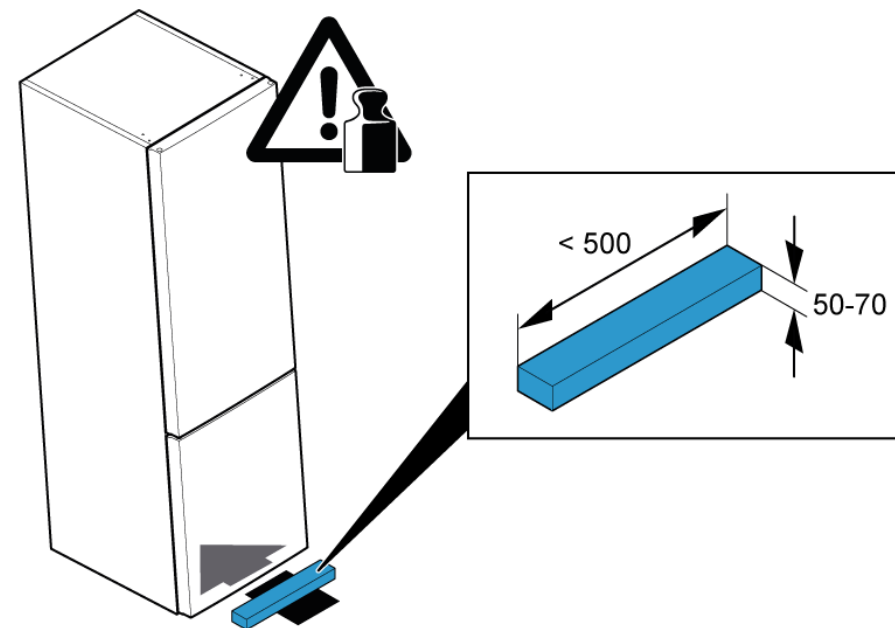

2.
 1. Remova a tampa da dobradiça superior (1).
 2. Desaperte dois parafusos (2).
 3. Remova a dobradiça superior (3).

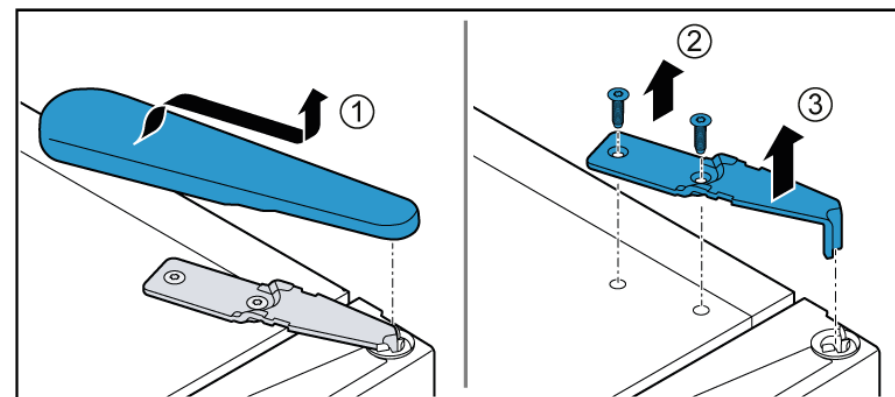

3. Remova a porta superior.

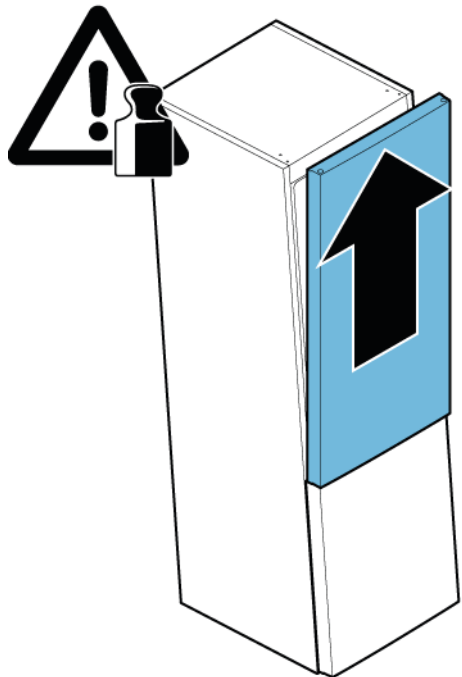

 A dobradiça superior está removida.



4.3.2 Instalar a dobradiça superior da porta



► Instale pela ordem inversa.



4.4 Substituir a dobradiça superior da porta (porta com visor)



Ferramentas necessárias:

 Ponta Torx TX20 6,3 mm (1/4") [00340865]



	 AVISO
	Aparelhos pesados e volumosos! Lesões nas costas e musculares <ul style="list-style-type: none">▶ A operação de remoção da porta do aparelho deve ser apenas executada por especialistas formados.▶ São necessárias duas pessoas para mover o aparelho.▶ Use apenas ferramentas e equipamento adequados.



	 CUIDADO
	Arestas vivas! Lesões por corte <ul style="list-style-type: none">▶ Use luvas de proteção.

	 AVISO
	Deslizamento de aparelhos inclinados! Fraturas ósseas / ferimentos de esmagamento <ul style="list-style-type: none">▶ Proteja os aparelhos contra o deslizamento.



	 CUIDADO
	Risco de queda de peças devido a parafusos desapertados! Lesões devido à queda de peças. <ul style="list-style-type: none">▶ Proteja o componente contra as quedas.

	ATENÇÃO!
	Risco de queda de peças devido a parafusos desapertados! Danos em outros componentes do aparelho ou na casa do cliente, p. ex., no pavimento. <ul style="list-style-type: none">▶ Proteja o componente contra as quedas.

	 PERIGO
	Risco de choque elétrico devido a partes sob tensão! Risco de vida devido a choque elétrico em caso de reparação inadequada <ul style="list-style-type: none">▶ As partes elétricas devem ser reparadas por um electricista qualificado.▶ Após a reparação, solicite a realização de um teste de segurança de acordo com VDE 0701 ou os regulamentos específicos do país.

	 PERIGO
	Risco de choque elétrico devido a partes sob tensão! Morte por eletrocussão <ul style="list-style-type: none">▶ Desligue os aparelhos da alimentação elétrica pelo menos 60 segundos antes de iniciar as reparações.

Pré-requisito:

-  O aparelho está desligado da alimentação elétrica.
-  As fixações interiores do aparelho estão removidas.

4.4.1 Remover a dobradiça superior da porta

1. Deslize a peça de apoio por baixo da secção da base.

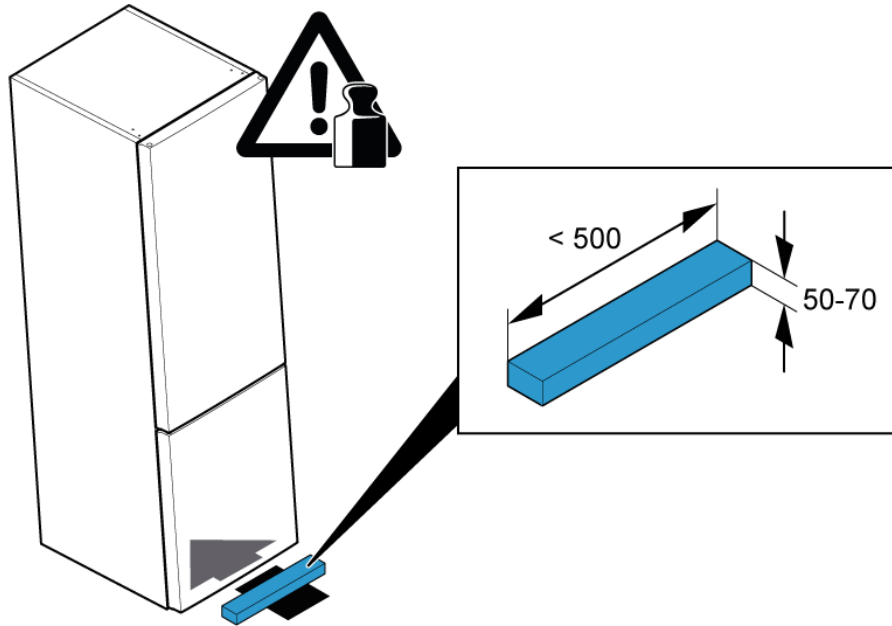

2. 1. Remova a tampa da dobradiça superior (1).
2. Desconecte a ligação elétrica (2).
3. Desaperte o parafuso de ligação à terra (3).

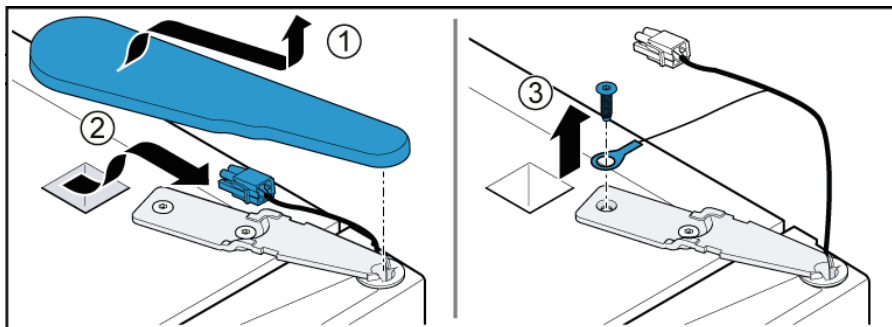

3. 1. Desaperte o parafuso (1).
2. Remova a dobradiça superior (2).

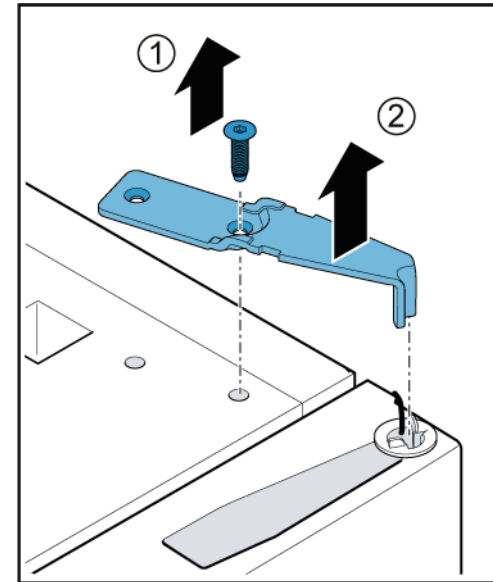

4. Remova a porta superior.

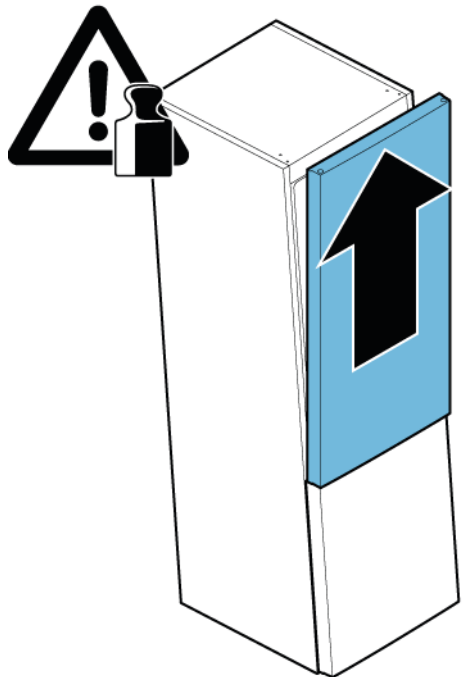

 A dobradiça superior está removida.

4.4.2 Instalar a dobradiça superior da porta

► Instale pela ordem inversa.

4.5 Substituir a dobradiça central da porta

Ferramentas necessárias:

🔧 Ponta Torx TX20 6,3 mm (1/4") [00340865]

	⚠️ AVISO
	Aparelhos pesados e volumosos! Lesões nas costas e musculares <ul style="list-style-type: none">▶ A operação de remoção da porta do aparelho deve ser apenas executada por especialistas formados.▶ São necessárias duas pessoas para mover o aparelho.▶ Use apenas ferramentas e equipamento adequados.

	⚠️ CUIDADO
	Arestas vivas! Lesões por corte <ul style="list-style-type: none">▶ Use luvas de proteção.

	⚠️ AVISO
	Deslizamento de aparelhos inclinados! Fraturas ósseas / ferimentos de esmagamento <ul style="list-style-type: none">▶ Proteja os aparelhos contra o deslizamento.

	⚠️ CUIDADO
	Risco de queda de peças devido a parafusos desapertados! Lesões devido à queda de peças. <ul style="list-style-type: none">▶ Proteja o componente contra as quedas.

	ATENÇÃO!
	Risco de queda de peças devido a parafusos desapertados! Danos em outros componentes do aparelho ou na casa do cliente, p. ex., no pavimento. <ul style="list-style-type: none">▶ Proteja o componente contra as quedas.

Pré-requisito:

- ✔ O aparelho está desligado da alimentação elétrica.
- ✔ As fixações interiores do aparelho estão removidas.
- ✔ A dobradiça superior da porta está removida.

✔ A porta superior está removida.

4.5.1 Remover a dobradiça central da porta

1. Desaperte dois parafusos (1).
2. Remova a dobradiça central (2).

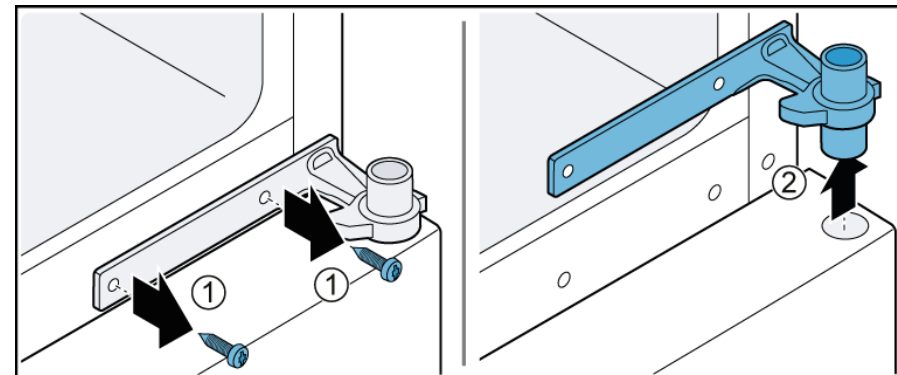

2. Remova a porta inferior.

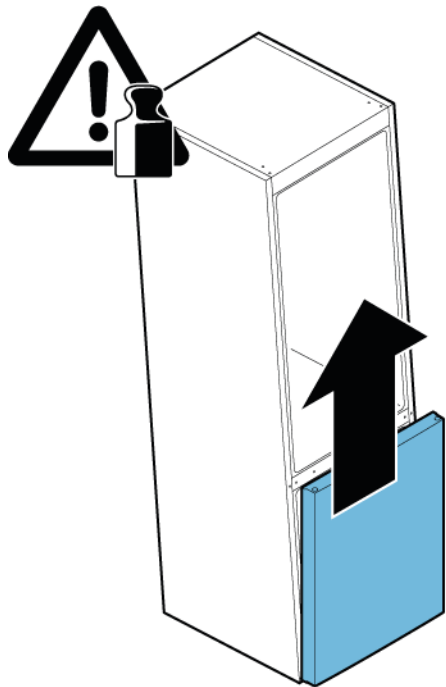

➡ A dobradiça central está removida.

4.5.2 Instalar a dobradiça central da porta

▶ Instale pela ordem inversa.

4.6 Substituir a dobradiça inferior da porta

Ferramentas necessárias:

🔧 Ponta Torx TX20 6,3 mm (1/4") [00340865]

	⚠️ AVISO
	Aparelhos pesados e volumosos! Lesões nas costas e musculares <ul style="list-style-type: none">▶ A operação de remoção da porta do aparelho deve ser apenas executada por especialistas formados.▶ São necessárias duas pessoas para mover o aparelho.▶ Use apenas ferramentas e equipamento adequados.

	⚠️ CUIDADO
	Arestas vivas! Lesões por corte <ul style="list-style-type: none">▶ Use luvas de proteção.

	⚠️ AVISO
	Deslizamento de aparelhos inclinados! Fraturas ósseas / ferimentos de esmagamento <ul style="list-style-type: none">▶ Proteja os aparelhos contra o deslizamento.

	⚠️ CUIDADO
	Risco de queda de peças devido a parafusos desapertados! Lesões devido à queda de peças. <ul style="list-style-type: none">▶ Proteja o componente contra as quedas.

	ATENÇÃO!
	Risco de queda de peças devido a parafusos desapertados! Danos em outros componentes do aparelho ou na casa do cliente, p. ex., no pavimento. <ul style="list-style-type: none">▶ Proteja o componente contra as quedas.

Pré-requisito:

- ✔ O aparelho está desligado da alimentação elétrica.
- ✔ As fixações interiores do aparelho estão removidas.
- ✔ A dobradiça superior está removida.

✔ A dobradiça central está removida.

4.6.1 Remover a dobradiça inferior da porta

- ▶ 1. Desaperte dois parafusos (1).
- ▶ 2. Remova a dobradiça inferior (2).

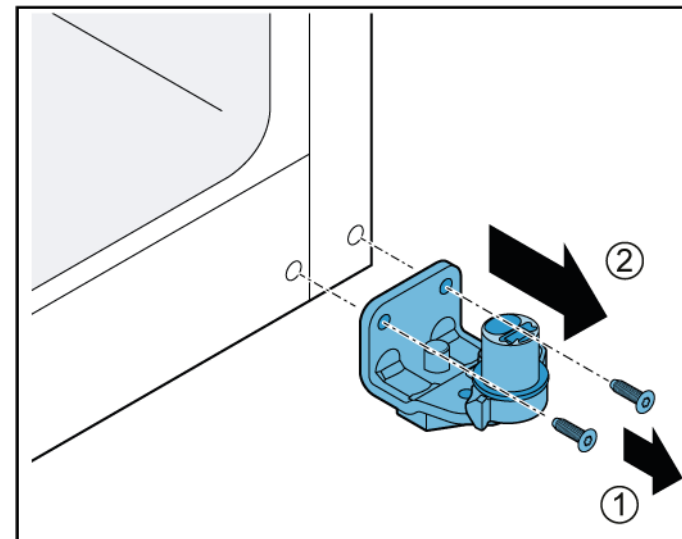

➡ A dobradiça inferior da porta está removida.

4.6.2 Instalar a dobradiça inferior da porta

- ▶ Instale pela ordem inversa.

4.7 Substituir a prateleira

Pré-requisito:

- ✔ A porta está aberta.

4.7.1 Remover a prateleira

- ▶ 1. Levante a prateleira atrás (1).
- ▶ 2. Solte a prateleira (2).

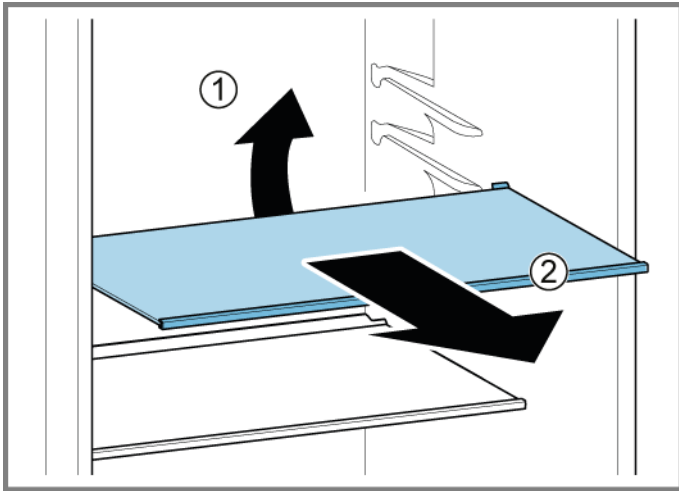

➡ A prateleira está removida.

4.7.2 Instalar a prateleira

- ▶ Instale pela ordem inversa.

4.8 Substituir o suporte para garrafas

Pré-requisito:

- ✔ A porta está aberta.

4.8.1 Remover o suporte para garrafas

- ▶ Puxe para fora o suporte para garrafas.

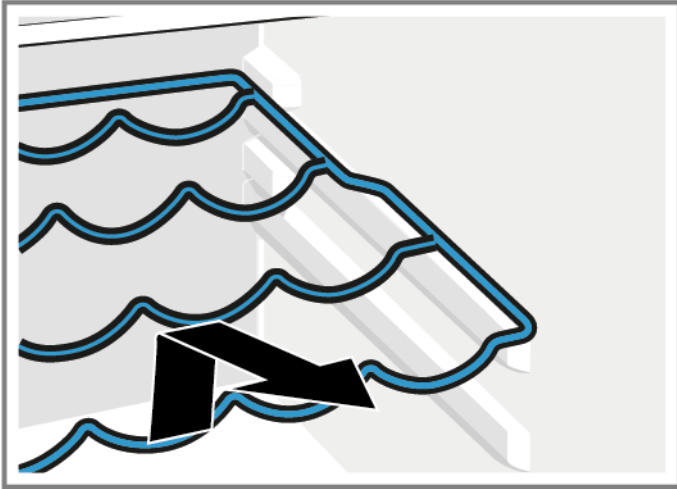

- ➡ O suporte para garrafas está removido.

4.8.2 Instalar o suporte para garrafas

- ▶ Instale pela ordem inversa.

4.9 Substituir a prateleira da porta

Pré-requisito:

- ✔ A porta está aberta.

4.9.1 Remover a prateleira da porta

- ▶ Levante a prateleira da porta.

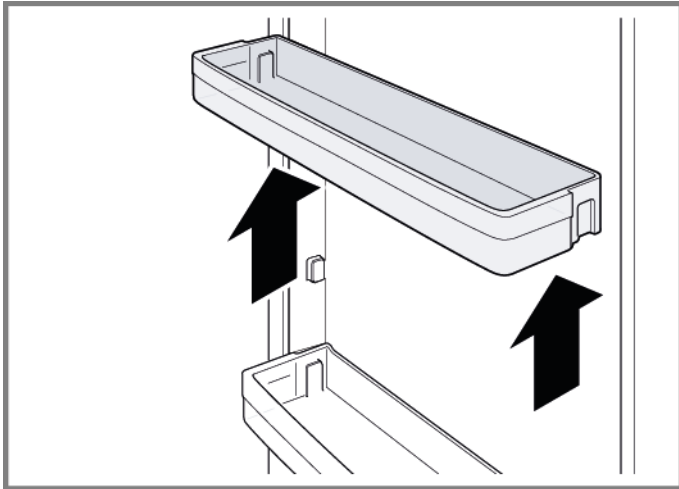

➡ A prateleira da porta está removida.

4.9.2 Instalar a prateleira da porta

- ▶ Instale pela ordem inversa.

4.10 Substituir o recipiente de armazenamento

Pré-requisito:

- ✔ A porta está aberta.

4.10.1 Remover o recipiente de armazenamento

1. Puxe o recipiente de armazenamento para fora até ao máximo.
2. 1. Levante o recipiente de armazenamento à frente (1).
2. Remova o recipiente (2).

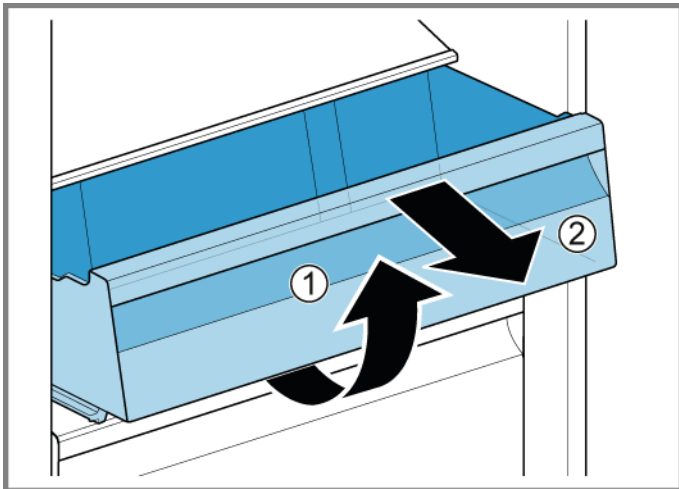

- ➔ O recipiente de armazenamento está removido.

4.10.2 Instalar o recipiente de armazenamento

- ▶ Instale pela ordem inversa.

4.11 Substituir o recipiente para fruta e vegetais

Pré-requisito:

- ✔ A porta está aberta.

4.11.1 Remover o recipiente para fruta e vegetais

1. Puxe o recipiente para fruta e vegetais para fora até ao máximo.
2. 1. Levante o recipiente para fruta e vegetais à frente (1).
2. Remova o recipiente (2).

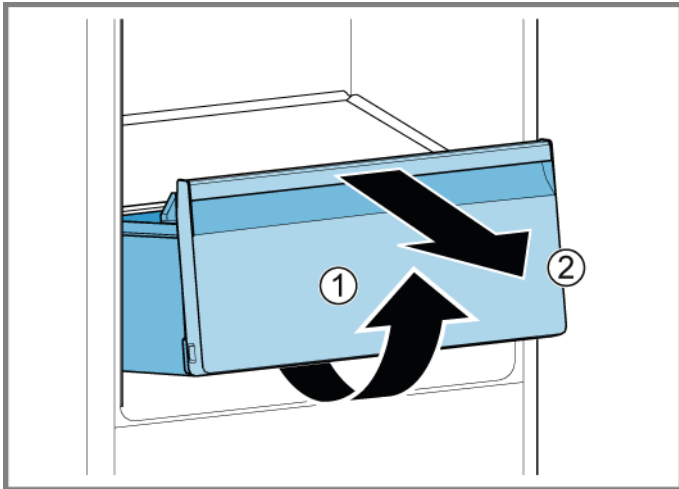

- ➡ O recipiente para fruta e vegetais está removido.

4.11.2 Instalar o recipiente para fruta e vegetais

- ▶ Instale pela ordem inversa.

4.12 Substituir a prateleira sobre o recipiente para fruta e vegetais

Pré-requisito:

- ✔ A porta está aberta.
- ✔ [O recipiente para fruta e vegetais está removido.→527](#)

4.12.1 Remover a prateleira sobre o recipiente para fruta e vegetais

1. Empurre a estrutura de vedação para cima e para fora.

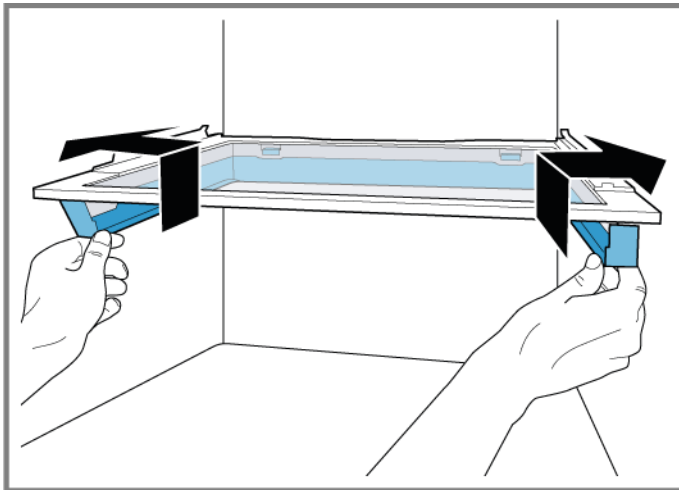

- ➡ Os ganchos laterais estão soltos.

2. Levante a estrutura de vedação e deslize-a para trás.

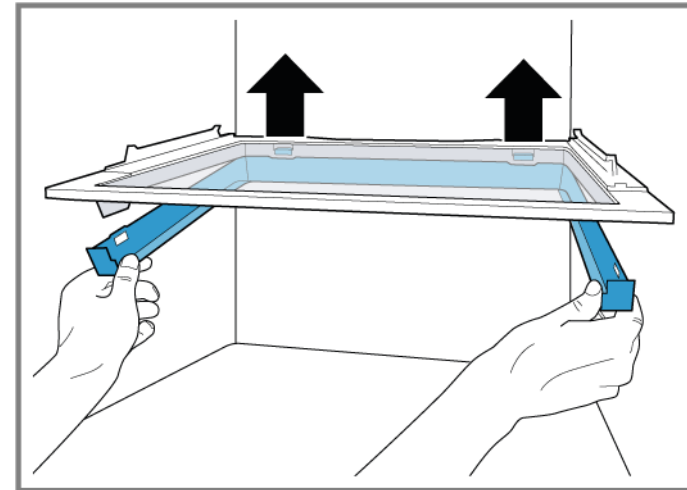

- ➡ Os ganchos traseiros estão soltos.

3. Remova a estrutura de vedação.
4. Levante a prateleira por cima do recipiente para fruta e vegetais e gire-a para fora lateralmente.

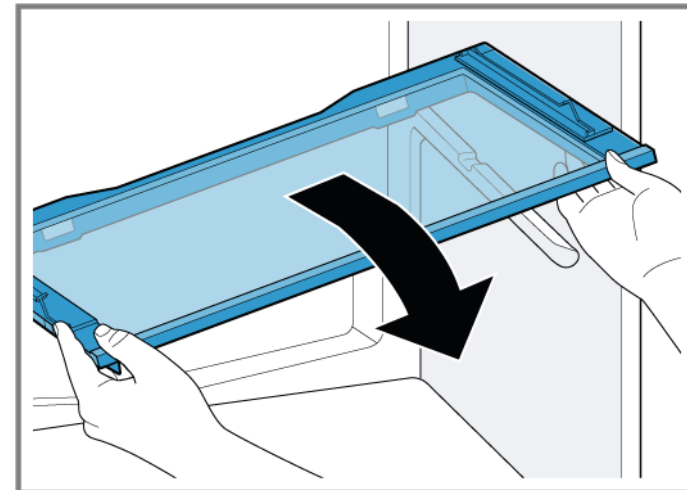

- ➡ A prateleira por cima do recipiente para fruta e vegetais está removida.

4.12.2 Instalar a prateleira por cima do recipiente para fruta e vegetais

- ▶ Instale pela ordem inversa.

4.13 Substituir o recipiente para alimentos congelados

Pré-requisito:

- ✔ A porta está aberta.

4.13.1 Remover o recipiente para alimentos congelados

- ▶ 1. Puxe o recipiente para alimentos congelados inteiramente para fora (1).
- ▶ 2. Remova o recipiente para alimentos (2).

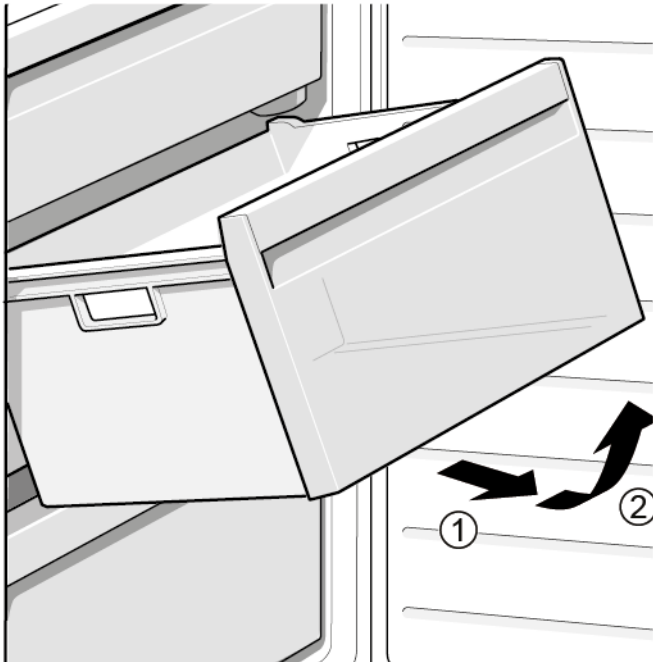

- ➡ O recipiente para alimentos congelados está removido.

4.13.2 Instalar o recipiente para alimentos congelados

- ▶ Instale pela ordem inversa.

4.14 Substituir a lâmpada LED superior

Ferramentas necessárias:

 Ferramenta especial

[00342180]



O seu aparelho dispõe de uma iluminação LED isenta de manutenção. Estas iluminações só podem ser reparadas pelo serviço de apoio ao consumidor ou por técnicos autorizados!



PERIGO

Risco de choque elétrico devido a partes sob tensão!

Risco de vida devido a choque elétrico em caso de reparação inadequada

- ▶ As partes elétricas devem ser reparadas por um electricista qualificado.
- ▶ Após a reparação, solicite a realização de um teste de segurança de acordo com VDE 0701 ou os regulamentos específicos do país.



PERIGO

Risco de choque elétrico devido a partes sob tensão!

Morte por eletrocussão

- ▶ Desligue os aparelhos da alimentação elétrica pelo menos 60 segundos antes de iniciar as reparações.





CUIDADO

Arestas vivas!

Lesões por corte

- ▶ Use luvas de proteção.

Pré-requisito:

-  O aparelho está desligado da energia.
-  A porta está aberta.

4.14.1 Remover a lâmpada LED superior

1. Deslize a ferramenta de desmontagem entre a lâmpada LED superior e o revestimento interno do compartimento de refrigeração para soltar os ganchos da lâmpada (1).
2. Remova a lâmpada LED superior (2).

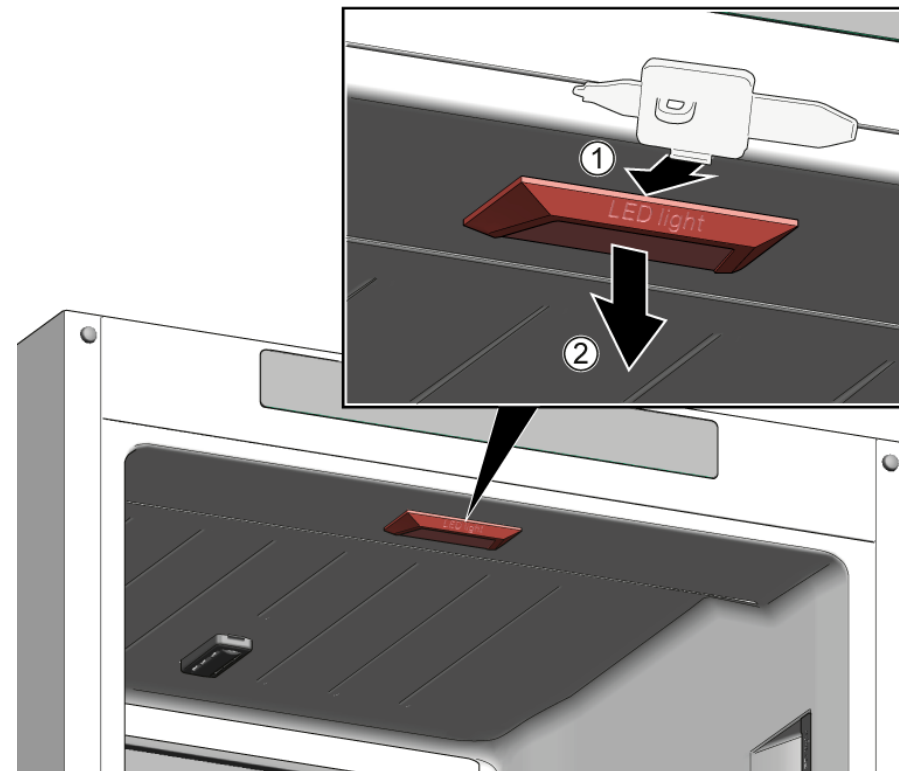

2. Desconecte a ligação elétrica da lâmpada LED superior.
-  A lâmpada LED superior está removida.

4.14.2 Instalar a lâmpada LED superior

- ▶ Instale pela ordem inversa.

4.15 Substituir a lâmpada LED lateral

Ferramentas necessárias:

 Ferramenta especial [00342180]

	O seu aparelho dispõe de uma iluminação LED isenta de manutenção. Estas iluminações só podem ser reparadas pelo serviço de apoio ao consumidor ou por técnicos autorizados!
---	---



	PERIGO Risco de choque elétrico devido a partes sob tensão! Risco de vida devido a choque elétrico em caso de reparação inadequada <ul style="list-style-type: none">▶ As partes elétricas devem ser reparadas por um electricista qualificado.▶ Após a reparação, solicite a realização de um teste de segurança de acordo com VDE 0701 ou os regulamentos específicos do país.
--	---

	PERIGO Risco de choque elétrico devido a partes sob tensão! Morte por eletrocussão <ul style="list-style-type: none">▶ Desligue os aparelhos da alimentação elétrica pelo menos 60 segundos antes de iniciar as reparações.
--	---

	CUIDADO Arestas vivas! Lesões por corte <ul style="list-style-type: none">▶ Use luvas de proteção.
---	--

	ATENÇÃO! Risco de danos em componentes electrostaticamente sensíveis (ESDs)! Danos nos componentes <ul style="list-style-type: none">▶ Antes de tocar em ESDs, usar um sistema de proteção eletrostático (pulseira com ficha de proteção de terra).▶ Não toque em ligações e percursos condutores dos módulos.▶ Apenas transporte os ESDs em materiais condutores ou na embalagem original.▶ Mantenha os ESDs afastados dos materiais que possam ser carregados electrostaticamente (por exemplo: plástico).
---	---

Pré-requisito:

-  O aparelho está desligado da energia.
-  A porta está aberta.
-  As fixações interiores do RC estão removidas.

4.15.1 Remover a lâmpada LED lateral

1. Deslize a ferramenta de desmontagem entre o difusor da lâmpada e a caixa para soltar o gancho (1).
2. Retire o difusor da lâmpada (2).
3. Solte os ganchos de fixação do difusor subsequentes da mesma forma.

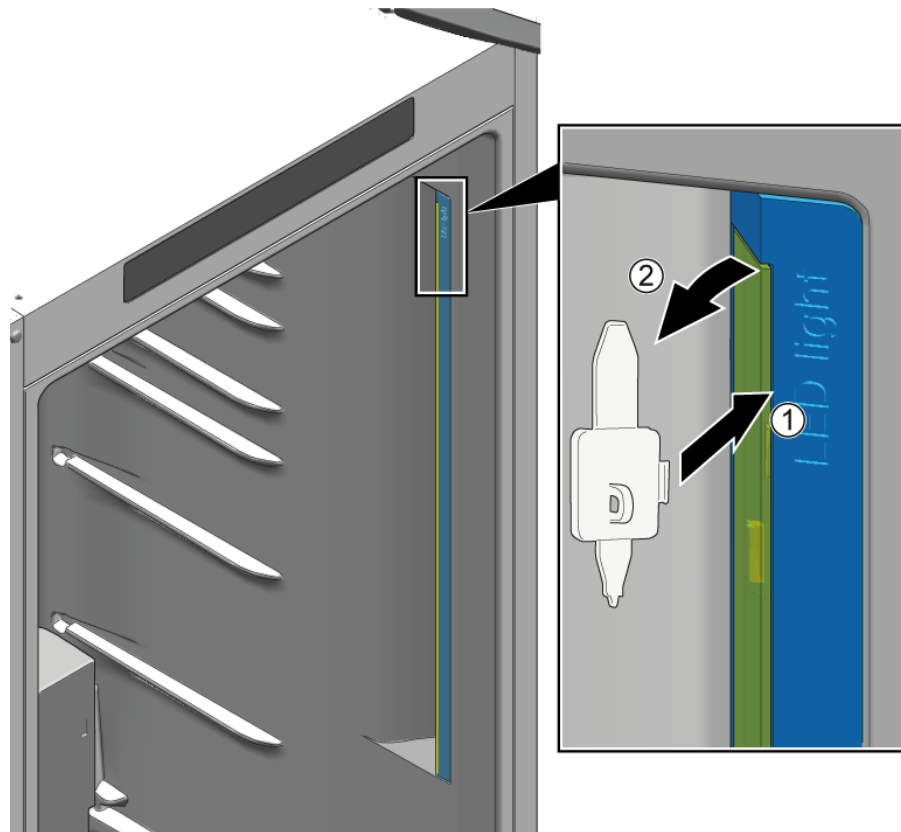

 O difusor da lâmpada está removido.

1. Pressione os ganchos de fixação para o soltar (1).
2. Desloque o módulo LED para cima aprox. 1 cm para remover, a fim de o desligar da tomada elétrica (2).
3. Remova o módulo LED (3).

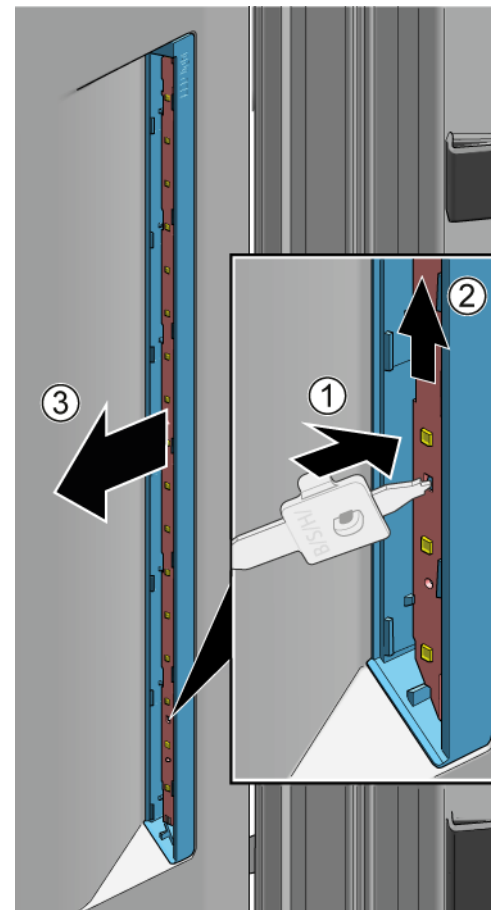

 A lâmpada LED lateral está removida.

4.15.2 Instalar a lâmpada LED lateral



Uma vez que os ganchos do difusor da lâmpada quebram facilmente durante o processo de remoção, a lâmpada LED sobressalente é o conjunto que inclui o módulo LED e o difusor da lâmpada.

Reparação

1. Deslize a ferramenta de desmontagem entre o difusor da lâmpada e a caixa para soltar o gancho (1).
2. Retire o difusor da lâmpada (2).
3. Solte os ganchos de fixação do difusor subsequentes da mesma forma.

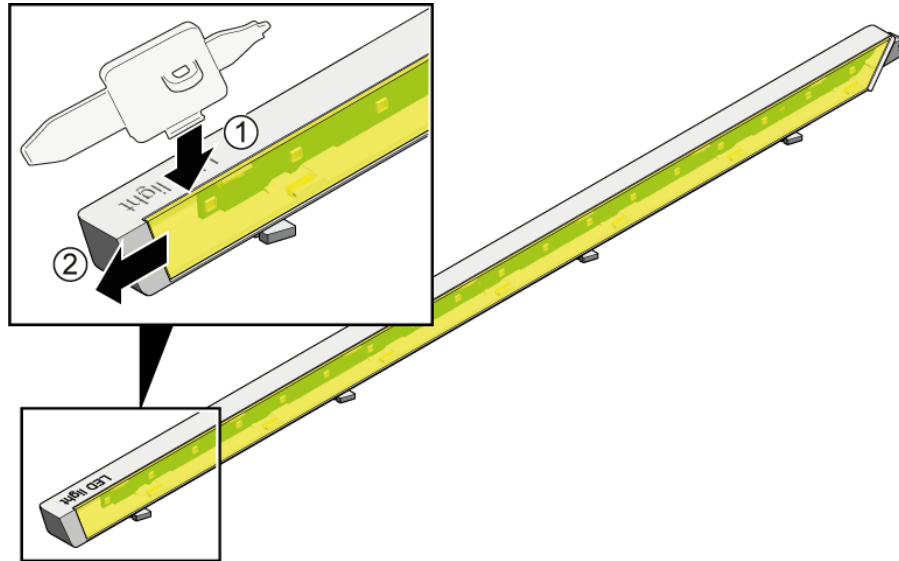

2. 1. Pressione os ganchos de fixação para o soltar (1).
2. Deslize o módulo LED para cima e para fora da caixa.
3. Descarte a caixa do módulo LED que é usada por razões de segurança no transporte de peças sobressalentes (3).

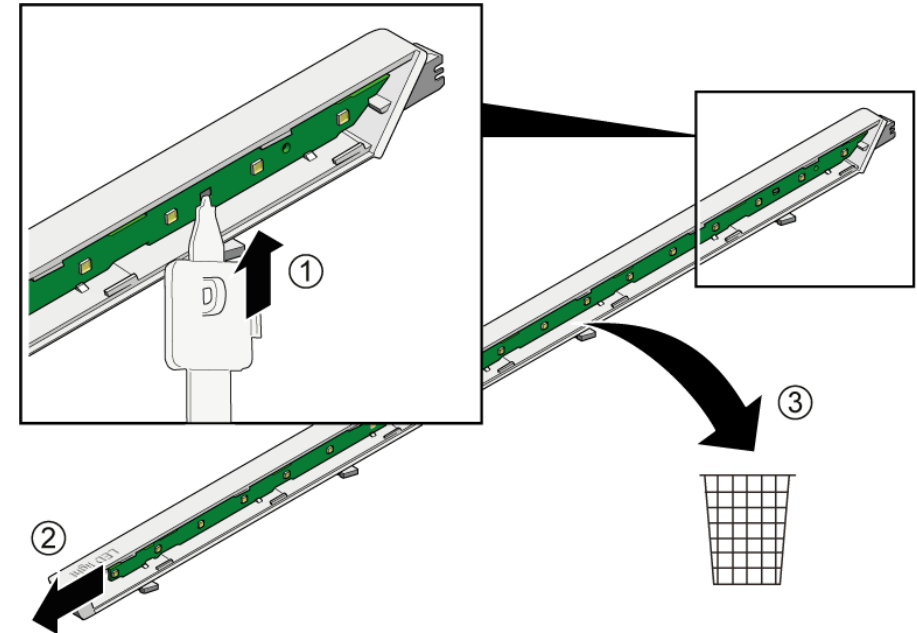

3. Instale o módulo LED e o difusor da lâmpada pela ordem inversa à da remoção.

4.16 Substituir a lâmpada LED do congelador

Ferramentas necessárias:

Ferramenta especial [00342180]



O seu aparelho dispõe de uma iluminação LED isenta de manutenção. Estas iluminações só podem ser reparadas pelo serviço de apoio ao consumidor ou por técnicos autorizados!



PERIGO

Risco de choque elétrico devido a partes sob tensão!

Risco de vida devido a choque elétrico em caso de reparação inadequada

- ▶ As partes elétricas devem ser reparadas por um electricista qualificado.
- ▶ Após a reparação, solicite a realização de um teste de segurança de acordo com VDE 0701 ou os regulamentos específicos do país.



PERIGO

Risco de choque elétrico devido a partes sob tensão!

Morte por eletrocussão

- ▶ Desligue os aparelhos da alimentação elétrica pelo menos 60 segundos antes de iniciar as reparações.



CUIDADO

Arestas vivas!

Lesões por corte

- ▶ Use luvas de proteção.

Pré-requisito:

- ✔ O aparelho está desligado da energia.
- ✔ A porta está aberta.

4.16.1 Remover a lâmpada LED do congelador

- ▶ 1. Deslize a ferramenta de desmontagem entre a lâmpada e o invólucro do lado da lâmpada para criar uma separação (1).
- ▶ 2. Deslize a ferramenta de desmontagem do outro lado do gancho de fixação da lâmpada e rode-a para a frente (2).
- ▶ 3. Remova a lâmpada LED do congelador (3).

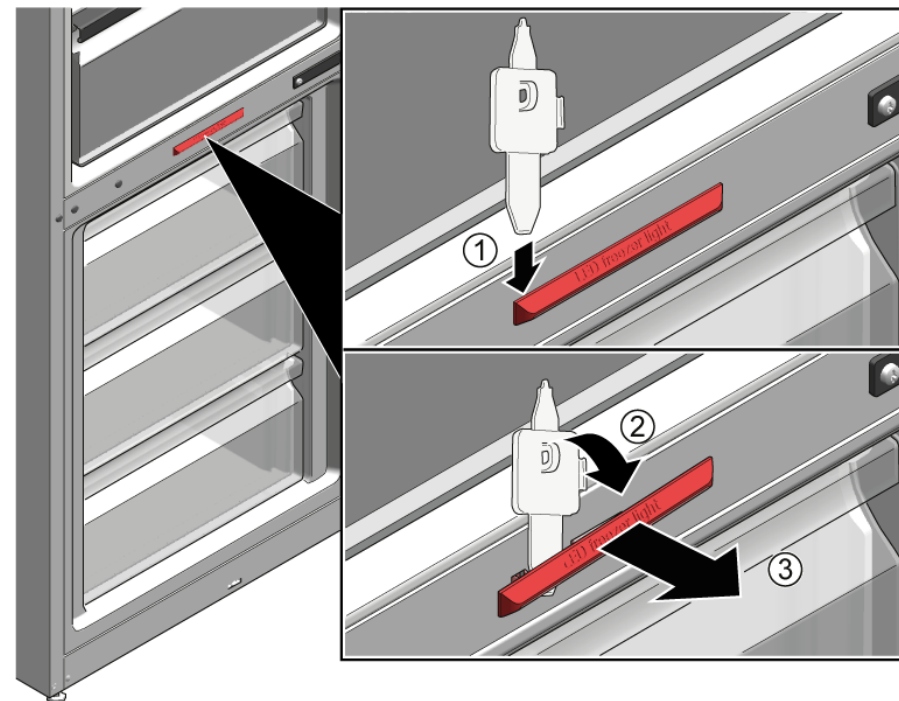

- ➡ A lâmpada LED do congelador está desconectada.
- ➡ A lâmpada LED do congelador está removida.

4.16.2 Instalar a lâmpada LED do congelador

- ▶ Instale pela ordem inversa.

Indicii pentru reparații - Combinație aparat de răcire/congelare

Referitor la acest document..... 537

1.1	Informații importante	537
1.1.1	Aplicabilitatea	537
1.2	Explicația simbolurilor	537
1.2.1	Nivelurile de pericol	537
1.2.2	Simbolurile de pericol	537
1.2.3	Structura avertismentelor	538
1.2.4	Simbolurile generale	538

Siguranța..... 539

2.1	Instrucțiuni generale de siguranță	539
2.1.1	Toate aparatele electrocasnice	539

Instrumente și materiale utile..... 540

Repararea..... 541

4.1	Înlocuirea garniturii ușii	541
4.1.1	Demontarea garniturii ușii	541
4.1.2	Montarea garniturii ușii	541
4.2	Înlocuirea mânerului ușii	544
4.2.1	Demontarea mânerului ușii	544
4.2.2	Montarea mânerului ușii	544
4.3	Înlocuirea balamalei de sus a ușii	545
4.3.1	Demontarea balamalei de sus a ușii	545
4.3.2	Montarea balamalei de sus a ușii	546
4.4	Înlocuirea balamalei de sus a ușii (ușă cu afișaj)	547
4.4.1	Demontarea balamalei de sus a ușii	548
4.4.2	Montarea balamalei de sus a ușii	549
4.5	Înlocuirea balamalei din mijloc a ușii	550
4.5.1	Demontarea balamalei din mijloc a ușii	550
4.5.2	Montarea balamalei din mijloc a ușii	551
4.6	Înlocuirea balamalei de jos a ușii	552
4.6.1	Demontarea balamalei de jos a ușii	552
4.6.2	Montarea balamalei de jos a ușii	552
4.7	Repoziționarea raftului	553
4.7.1	Demontarea raftului	553
4.7.2	Montarea raftului	553

4.8	Repoziționarea suportului pentru sticle	554
4.8.1	Demontarea suportului pentru sticle	554
4.8.2	Montarea suportului pentru sticle	554
4.9	Repoziționarea raftului pentru ușă	555
4.9.1	Demontarea raftului pentru ușă	555
4.9.2	Montarea raftului pentru ușă	555
4.10	Repoziționarea containerului de depozitare	556
4.10.1	Demontarea containerului de depozitare	556
4.10.2	Montarea containerului de depozitare	556
4.11	Repoziționarea containerului pentru fructe și legume	557
4.11.1	Demontarea containerului pentru fructe și legume	557
4.11.2	Montarea containerului pentru fructe și legume	557
4.12	Repoziționarea raftului de deasupra containerului pentru fructe și legume	558
4.12.1	Demontarea raftului de deasupra containerului pentru fructe și legume	558
4.12.2	Montarea raftului de deasupra containerului pentru fructe și legume	559
4.13	Repoziționarea containerului pentru alimente înghețate	560
4.13.1	Demontarea containerului pentru alimente înghețate	560
4.13.2	Montarea containerului pentru alimente înghețate	560
4.14	Înlocuirea lămpii LED de sus	561
4.14.1	Demontarea lămpii LED de sus	561
4.14.2	Montarea lămpii LED de sus	561
4.15	Înlocuirea lămpii LED laterale	562
4.15.1	Demontarea lămpii LED laterale	563
4.15.2	Montarea lămpii LED laterale	563
4.16	Înlocuirea lămpii LED din congelator	565
4.16.1	Demontarea lămpii LED din congelator	565
4.16.2	Montarea lămpii LED din congelator	565

i Referitor la acest document

1.1 Informații importante

1.1.1 Aplicabilitatea

Aceste instrucțiuni de reparare îl ajută pe client să își repare singur aparatele, în conformitate cu normele de proiectare ecologică aplicabile (începând cu 03/2021).



Acestea conțin informații privind modul de înlocuire a pieselor de schimb specifice, inclusiv avertismente și pericole.

Dacă aveți întrebări, vă rugăm să luați legătura cu serviciul relații clienți. Ne asumăm răspunderea pentru daune numai dacă instrucțiunile de reparare au fost respectate pe deplin.

1.2 Explicația simbolurilor

1.2.1 Nivelurile de pericol

Nivelurile de alertă sunt reprezentate printr-un simbol și un cuvânt de avertizare. Cuvântul de avertizare indică gravitatea pericolului.





Nivelul de alertă	Semnificație
 PERICOL	Nerespectarea mesajului de avertizare va provoca accidente grave sau decesul.
 AVERTISMENT	Nerespectarea mesajului de avertizare ar putea provoca accidente grave sau decesul.
 ATENȚIONARE	Nerespectarea mesajului de avertizare ar putea provoca accidente ușoare.
ATENȚIE!	Nerespectarea mesajului de avertizare ar putea provoca daune asupra proprietății.

Tabel 1: Nivelurile de pericol



1.2.2 Simbolurile de pericol

Simbolurile de pericol sunt reprezentări simbolice care indică tipul de pericol.

În acest document sunt utilizate simbolurile de pericol de mai jos:

Simbol de pericol	Semnificație
	Mesaj de avertizare general
	Pericol din cauza tensiunii electrice
	Pericol de explozie
	Pericol de tăiere
	Pericol de zdrobire

i Referitor la acest document

Simbol de pericol	Semnificație
	Pericol din cauza suprafețelor fierbinți
	Pericol din cauza câmpului magnetic puternic
	Pericol din cauza radiației neionizante

Tabel 2: Simbolurile de pericol

1.2.3 Structura avertismentelor

Avertismentele din acest document au un aspect și o structură standard.



	<div style="background-color: red; color: white; padding: 2px; text-align: center;">⚠ PERICOL</div> <p>Tipul și sursa pericolului! Consecințele posibile ale ignorării pericolului/avertismentului.</p> <ul style="list-style-type: none"> ▶ Măsuri și interdicții pentru prevenirea pericolului.
--	--









Exemplul următor prezintă un avertisment privind electrocutarea din cauza pieselor sub tensiune. Se menționează măsura necesară pentru a evita pericolul.

	<div style="background-color: red; color: white; padding: 2px; text-align: center;">⚠ PERICOL</div> <p>Pericol de electrocutare din cauza pieselor sub tensiune! Deces prin electrocutare</p> <ul style="list-style-type: none"> ▶ Deconectați aparatele de la sursa de alimentare cu tensiune cu cel puțin 60 de secunde înainte de a începe reparațiile.
---	---

1.2.4 Simbolurile generale

În acest document sunt utilizate simbolurile generale de mai jos:

Simbol general	Semnificație
	Identificarea unei recomandări speciale (text și/sau grafică)
	Identificarea unei recomandări simple (numai text)

Simbol general	Semnificație
	Identificarea unui link spre un videoclip instructiv
	Identificarea sculelor necesare
	Identificarea condițiilor preliminare necesare
	Identificarea unei stări (dacă..., apoi...)
	Identificarea unui rezultat
	Identificarea unei taste sau a unui buton
	Identificarea unui număr de serie
	Identificarea unui text/unei ferestre afișate (pe ecranul aparatului)

Tabel 3: Simbolurile generale

2.1 Instrucțiuni generale de siguranță

2.1.1 Toate aparatele electrocasnice

Pericol de electrocutare din cauza pieselor sub tensiune!

- Erorile care au loc în timpul reparațiilor efectuate la componentele electrice pot să ducă la electrocutări!
- Deconectați aparatul de la sursa de alimentare cu tensiune cu cel puțin 60 de secunde înainte de a începe lucrările.
- După reparație, este obligatorie efectuarea unei verificări de siguranță conform cu VDE 0701 sau cu reglementările naționale respective.

Pericol de rănire din cauza muchiilor ascuțite!

- Purtați mănuși de protecție.

Pericol de zdrobire în timpul lucrărilor de reparație, întreținere, depanare și service, din cauza componentelor grele și mobile

- Purtați încălțăminte de protecție.
- Fixați componentele grele împotriva căderii.
- Nu vă sprijiniți cu părți ale corpului de componentele mobile.

Pericol pentru siguranța/funcționarea aparatului!

- Utilizați numai piese de schimb originale.

Pericol de deteriorare a componentelor sensibile la electricitatea statică (ESD)!

- Nu atingeți modulele, inclusiv conexiunile și căile conductorilor.

Instrumente și materiale utile

Desemnare	Detalii	Imagini
Cap torx TX20 [00340865]	6,3 mm (1/4")	
Instrument special [00342180]		

4.1 Înlocuirea garniturii ușii

Cerință:

-  Ușa este deschisă.

4.1.1 Demontarea garniturii ușii

1. Îndepărtați garnitura ușii din canelura colțurilor din dreapta și stânga.



2. Demontați garnitura ușii din canelură.



-  Garnitura ușii este demontată.

4.1.2 Montarea garniturii ușii



Grosimea garniturii noi a ușii poate fi ușor diferită față de grosimea garniturii vechi a ușii. Acest lucru nu va afecta comportamentul de închidere și funcționarea pe termen lung.

Dacă aparatul dumneavoastră are balamale reglabile sau accesorii pentru balamale, puteți optimiza comportamentul de închidere în consecință.

Orificiile de mici dimensiuni practicate în garnitura ușii au rol funcțional (sunt necesare pentru ventilație). Ele nu sunt defecte ale produsului.

Repararea

1. Verificați canelura pentru montarea garniturii și asigurați-vă că nu prezintă defecte.

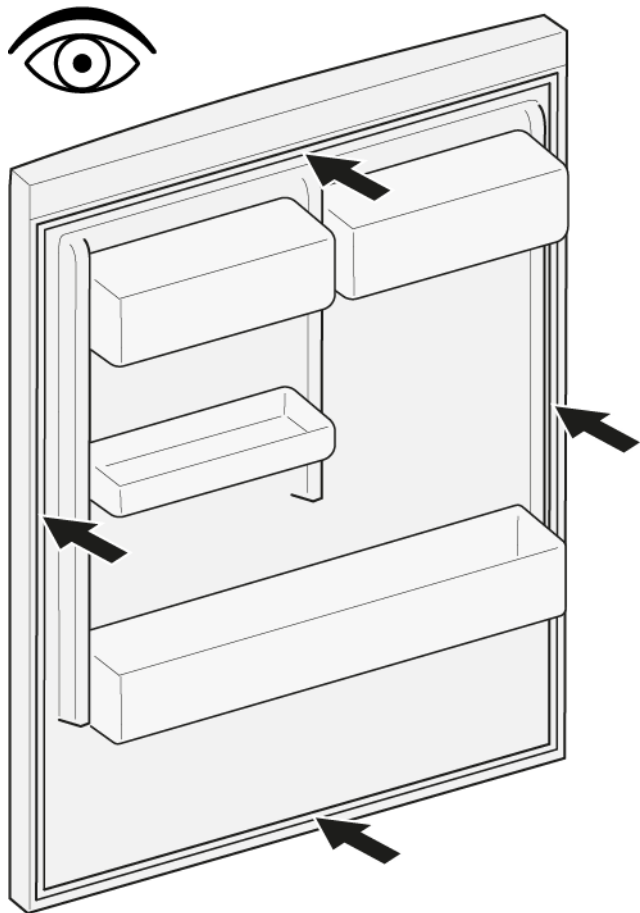

4. Împingeți colțurile de sus și de jos ale garniturii în canelură.

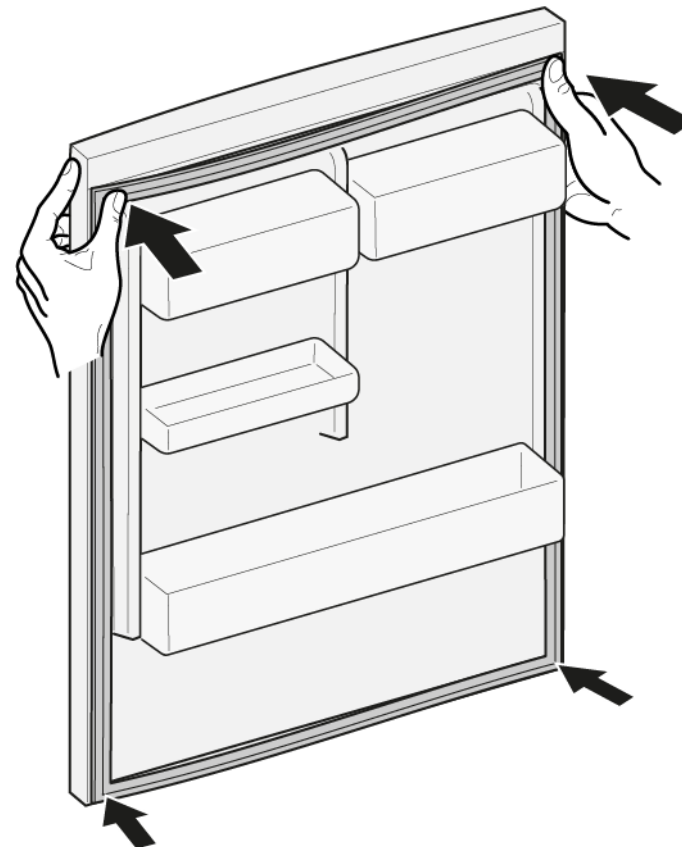

2.  Dacă canelura pentru montarea garniturii prezintă defecte, este deteriorată.
- Contactați departamentul de service pentru clienți.

3.  O deformare ușoară a garniturii ușii este normală și nu afectează funcționarea acesteia. Se recomandă să îndreptați garnitura ușii înainte de a o introduce în aparat.

Încălziți garnitura ușii cu un uscător de păr sau cu apă fierbinte și remodelați-o cu mâna.

Repararea

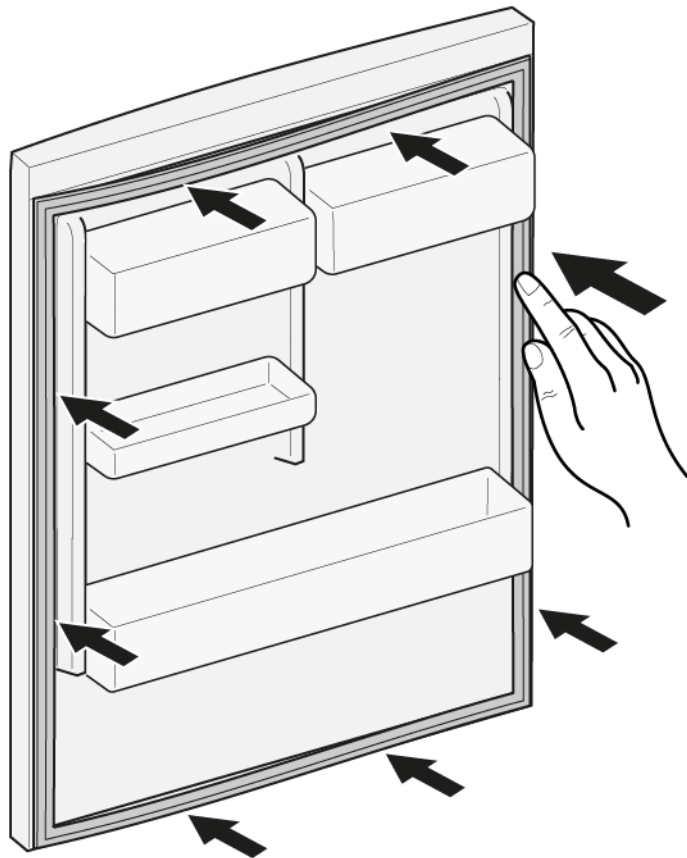

5. Apăsați întreaga garnitură în canelură, pas cu pas.



 Garnitura ușii este montată.

4.2 Înlocuirea mânerului ușii

Scule speciale:

-  Cap torx TX20 6,3 mm (1/4") [00340865]
-  Șurubelniță plată Lamă de 10 mm x 1,6 mm x 200 mm

Cerință:

-  Aparatul este deconectat de la sursa de energie electrică.
-  Ușa este deschisă.

4.2.1 Demontarea mânerului ușii

- ▶ 1. Demontați două capace de șuruburi (1).
- ▶ 2. Deșurubați două șuruburi (2).
- ▶ 3. Demontați mânerul ușii (3).

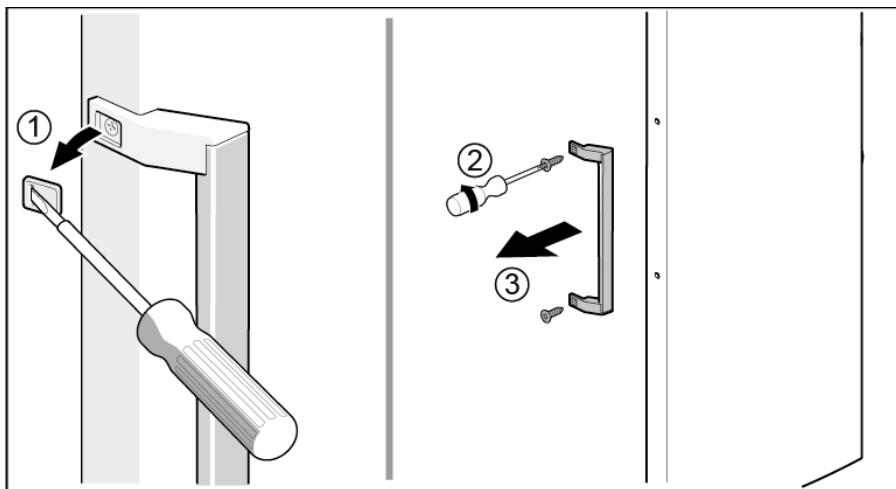

 Mânerul ușii este demontat.



Mânerul ușii pentru cea de-a doua ușă poate fi demontat în același mod.

4.2.2 Montarea mânerului ușii

- ▶ Montați urmând procedura de demontare în ordine inversă.

4.3 Înlocuirea balamalei de sus a ușii

Scule speciale:

Cap torx TX20

6,3 mm (1/4")

[00340865]

	AVERTISMENT
Aparate grele, masive!	
Accidentarea spatelui și leziuni musculare	
<ul style="list-style-type: none"> ▶ Operația de demontare a ușii aparatului trebuie efectuată numai de specialiști instruiți. ▶ Pentru deplasarea aparatului sunt necesare două persoane. ▶ Utilizați numai instrumente și echipamente adecvate. 	

	ATENȚIONARE
Marginea ascuțită!	
Rănire prin tăiere	
<ul style="list-style-type: none"> ▶ Purtați mănuși de protecție. 	

	AVERTISMENT
Alunecarea aparatelor înclinate!	
Fracturi/zdrobiri	
<ul style="list-style-type: none"> ▶ Fixați aparatele împotriva alunecării. 	

	ATENȚIONARE
Pericol din cauza pieselor care cad pentru că șuruburile sunt slăbite!	
Accidente din cauza pieselor care cad.	
<ul style="list-style-type: none"> ▶ Fixați componenta împotriva căderii. 	

	ATENȚIE!
Pericol din cauza pieselor care cad pentru că șuruburile sunt slăbite!	
Deteriorarea altor piese ale aparatului sau a casei clientului, de exemplu, partea de jos.	
<ul style="list-style-type: none"> ▶ Fixați componenta împotriva căderii. 	

Cerință:

- ✓ Aparatul este deconectat de la sursa de energie electrică.
- ✓ Fitingurile interioare ale aparatului sunt demontate.

4.3.1 Demontarea balamalei de sus a ușii

1. Glisați suportul sub secțiunea de bază.

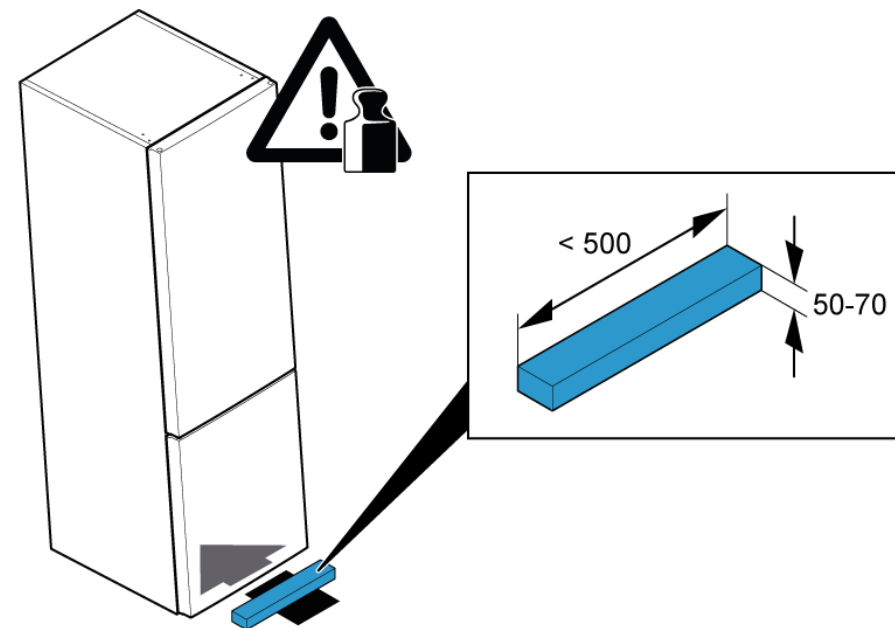

2.
 1. Demontați capacul balamalei de sus (1).
 2. Deșurubați două șuruburi (2).
 3. Demontați balamaua de sus (3).

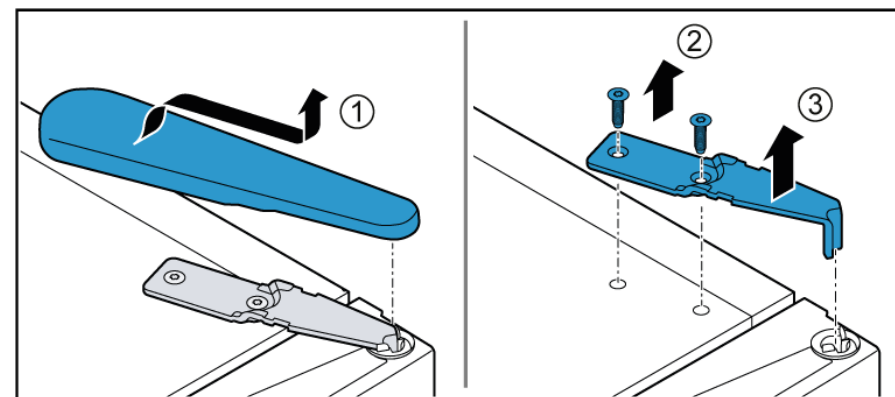

3. Demontați ușa de sus.

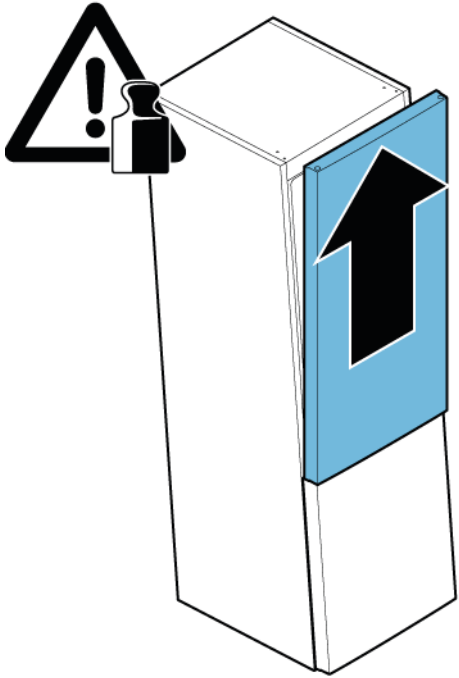

 Balamaua de sus este demontată.

4.3.2 Montarea balamalei de sus a ușii

▶ Montați urmând procedura de demontare în ordine inversă.

4.4 Înlocuirea balamalei de sus a ușii (ușă cu afișaj)

Scule speciale:

 Cap torx TX20 6,3 mm (1/4") [00340865]

	⚠️ AVERTISMENT
	<p>Aparate grele, masive! Accidentarea spatelui și leziuni musculare</p> <ul style="list-style-type: none"> ▶ Operația de demontare a ușii aparatului trebuie efectuată numai de specialiști instruiți. ▶ Pentru deplasarea aparatului sunt necesare două persoane. ▶ Utilizați numai instrumente și echipamente adecvate.

	⚠️ ATENȚIONARE
	<p>Marginea ascuțită! Rănire prin tăiere</p> <ul style="list-style-type: none"> ▶ Purtați mănuși de protecție.

	⚠️ AVERTISMENT
	<p>Alunecarea aparatelor înclinate! Fracturi/zdrobiri</p> <ul style="list-style-type: none"> ▶ Fixați aparatele împotriva alunecării.



	⚠️ ATENȚIONARE
	<p>Pericol din cauza pieselor care cad pentru că șuruburile sunt slăbite! Accidente din cauza pieselor care cad.</p> <ul style="list-style-type: none"> ▶ Fixați componenta împotriva căderii.

	ATENȚIE!
	<p>Pericol din cauza pieselor care cad pentru că șuruburile sunt slăbite! Deteriorarea altor piese ale aparatului sau a casei clientului, de exemplu, partea de jos.</p> <ul style="list-style-type: none"> ▶ Fixați componenta împotriva căderii.

	⚠️ PERICOL
	<p>Pericol de electrocutare din cauza pieselor sub tensiune! Pericol de moarte prin electrocutare în cazul unei reparații necorespunzătoare</p> <ul style="list-style-type: none"> ▶ Componentele electrice trebuie reparate de către electricieni calificați. ▶ După reparație, este obligatorie efectuarea unei verificări de siguranță conform cu VDE 0701 sau cu reglementările naționale respective.

	⚠️ PERICOL
	<p>Pericol de electrocutare din cauza pieselor sub tensiune! Deces prin electrocutare</p> <ul style="list-style-type: none"> ▶ Deconectați aparatele de la sursa de alimentare cu tensiune cu cel puțin 60 de secunde înainte de a începe reparațiile.

Cerință:

-  Aparatul este deconectat de la sursa de energie electrică.
-  Fitingurile interioare ale aparatului sunt demontate.

4.4.1 Demontarea balamalei de sus a ușii

1. Glisați suportul sub secțiunea de bază.

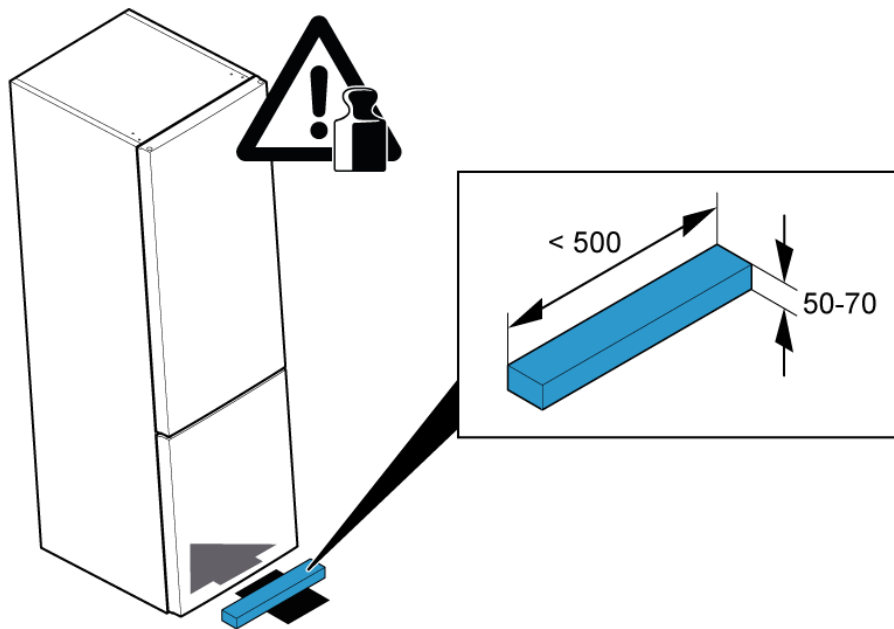

2. 1. Demontați capacul balamalei de sus (1).
2. Deconectați conexiunea electrică (2).
3. Deșurubați șurubul conexiunii de împământare (3).

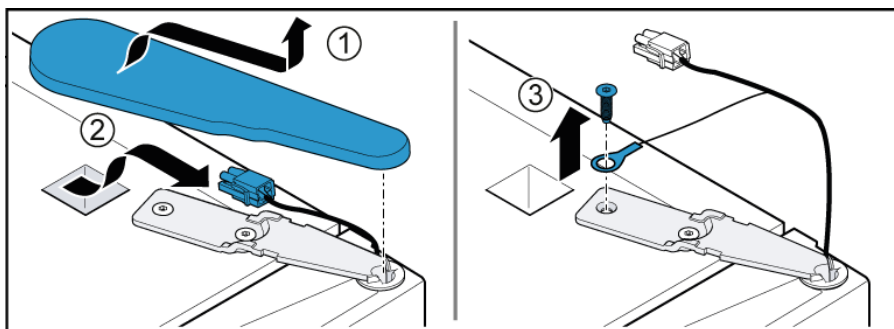

3. 1. Deșurubați șurubul (1).
2. Demontați balamaua de sus (2).

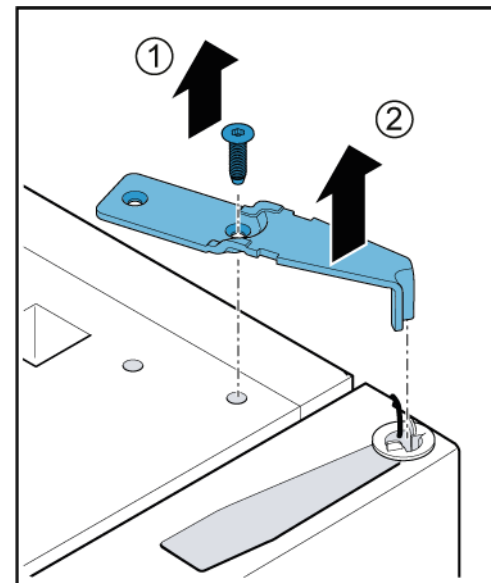

4. Demontați ușa de sus.

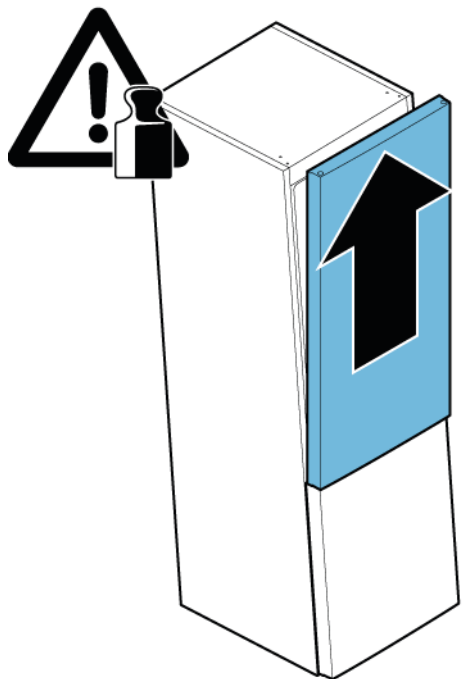

➡ Balamaua de sus este demontată.

4.4.2 Montarea balamalei de sus a ușii

- ▶ Montați urmând procedura de demontare în ordine inversă.

4.5 Înlocuirea balamalei din mijloc a ușii

Scule speciale:

🌀 Cap torx TX20

6,3 mm (1/4")

[00340865]

	⚠️ AVERTISMENT
	Aparate grele, masive! Accidentarea spatelui și leziuni musculare <ul style="list-style-type: none">▶ Operația de demontare a ușii aparatului trebuie efectuată numai de specialiști instruiți.▶ Pentru deplasarea aparatului sunt necesare două persoane.▶ Utilizați numai instrumente și echipamente adecvate.

	⚠️ ATENȚIONARE
	Marginea ascuțită! Rănire prin tăiere <ul style="list-style-type: none">▶ Purtați mănuși de protecție.

	⚠️ AVERTISMENT
	Alunecarea aparatelor înclinate! Fracturi/zdrobiri <ul style="list-style-type: none">▶ Fixați aparatele împotriva alunecării.

	⚠️ ATENȚIONARE
	Pericol din cauza pieselor care cad pentru că șuruburile sunt slăbite! Accidente din cauza pieselor care cad. <ul style="list-style-type: none">▶ Fixați componenta împotriva căderii.

	ATENȚIE!
	Pericol din cauza pieselor care cad pentru că șuruburile sunt slăbite! Deteriorarea altor piese ale aparatului sau a casei clientului, de exemplu, partea de jos. <ul style="list-style-type: none">▶ Fixați componenta împotriva căderii.

Cerință:

- ✔️ Aparatul este deconectat de la sursa de energie electrică.
- ✔️ Fitingurile interioare ale aparatului sunt demontate.

✔️ Balamaua de sus a ușii este demontată.

✔️ Ușa de sus este demontată.

4.5.1 Demontarea balamalei din mijloc a ușii

1. Deșurubați două șuruburi (1).
2. Scoateți balamaua din mijloc (2).

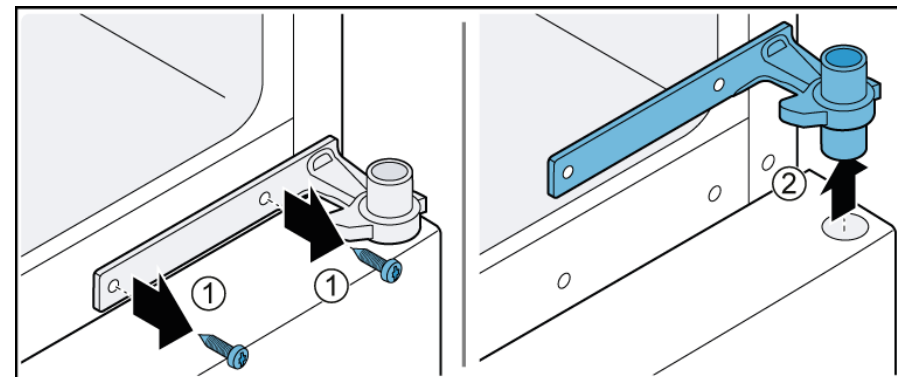

2. Demontați ușa de jos.

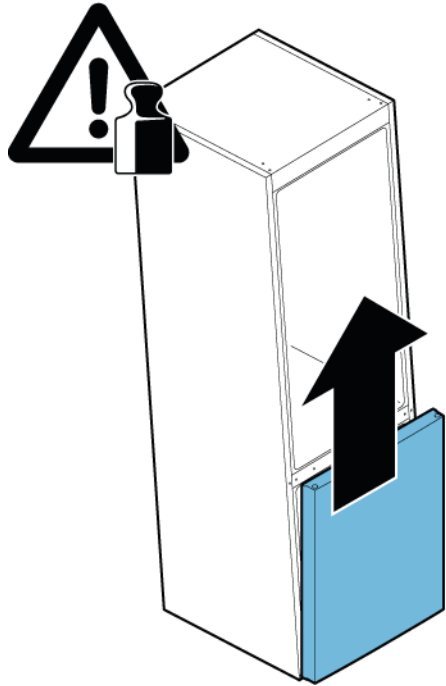

➡ Balamaua din mijloc este demontată.

4.5.2 Montarea balamalei din mijloc a ușii

- ▶ Montați urmând procedura de demontare în ordine inversă.

4.6 Înlocuirea balamalei de jos a ușii

Scule speciale:

🔩 Cap torx TX20

6,3 mm (1/4")

[00340865]

	⚠️ AVERTISMENT
	Aparate grele, masive! Accidentarea spatelui și leziuni musculare <ul style="list-style-type: none">▶ Operația de demontare a ușii aparatului trebuie efectuată numai de specialiști instruiți.▶ Pentru deplasarea aparatului sunt necesare două persoane.▶ Utilizați numai instrumente și echipamente adecvate.

	⚠️ ATENȚIONARE
	Marginea ascuțită! Rănire prin tăiere <ul style="list-style-type: none">▶ Purtați mănuși de protecție.

	⚠️ AVERTISMENT
	Alunecarea aparatelor înclinate! Fracturi/zdrobiri <ul style="list-style-type: none">▶ Fixați aparatele împotriva alunecării.

	⚠️ ATENȚIONARE
	Pericol din cauza pieselor care cad pentru că șuruburile sunt slăbite! Accidente din cauza pieselor care cad. <ul style="list-style-type: none">▶ Fixați componenta împotriva căderii.

	ATENȚIE!
	Pericol din cauza pieselor care cad pentru că șuruburile sunt slăbite! Deteriorarea altor piese ale aparatului sau a casei clientului, de exemplu, partea de jos. <ul style="list-style-type: none">▶ Fixați componenta împotriva căderii.

Cerință:

- ✔️ Aparatul este deconectat de la sursa de energie electrică.
- ✔️ Fitingurile interioare ale aparatului sunt demontate.

- ✔️ Balamaua de sus este demontată.
- ✔️ Balamaua din mijloc este demontată.

4.6.1 Demontarea balamalei de jos a ușii

- ▶ 1. Deșurubați două șuruburi (1).
- ▶ 2. Demontați balamaua de jos (2).

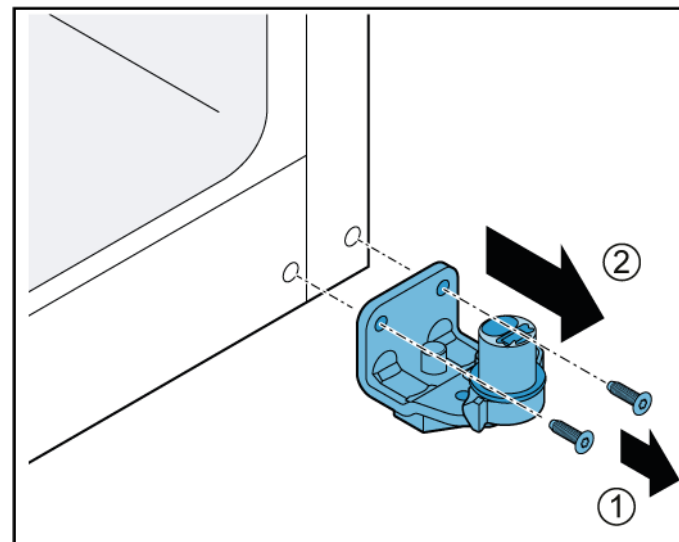

- ➡️ Balamaua de jos a ușii este demontată.

4.6.2 Montarea balamalei de jos a ușii

- ▶ Montați urmând procedura de demontare în ordine inversă.

4.7 Repoziționarea raftului

Cerință:

- ✔ Ușa este deschisă.

4.7.1 Demontarea raftului

- ▶ 1. Ridicați raftul de partea din spate (1).
- ▶ 2. Decuplați raftul (2).

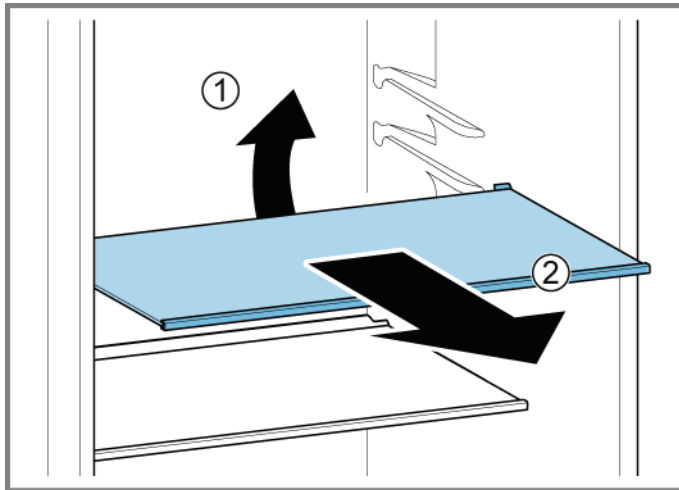

➡ Raftul este demontat.

4.7.2 Montarea raftului

- ▶ Montați urmând procedura de demontare în ordine inversă.

4.8 Repoziționarea suportului pentru sticle

Cerință:

- ✓ Ușa este deschisă.

4.8.1 Demontarea suportului pentru sticle

- ▶ Trageți suportul pentru sticle pentru a-l scoate.

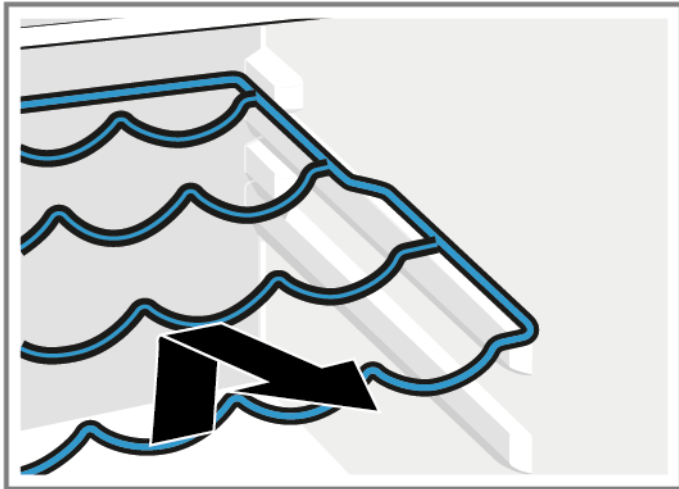

- ➡ Suportul pentru sticle este demontat.

4.8.2 Montarea suportului pentru sticle

- ▶ Montați urmând procedura de demontare în ordine inversă.

4.9 Repoziționarea raftului pentru ușă

Cerință:

- ✔ Ușa este deschisă.

4.9.1 Demontarea raftului pentru ușă

- ▶ Ridicați raftul pentru ușă.

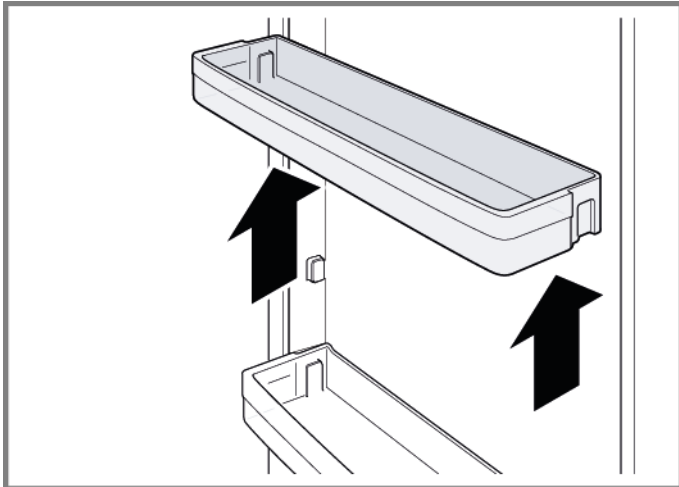

- ➡ Raftul pentru ușă este demontat.

4.9.2 Montarea raftului pentru ușă

- ▶ Montați urmând procedura de demontare în ordine inversă.

4.10 Repoziționarea containerului de depozitare

Cerință:

- ✔ Ușa este deschisă.

4.10.1 Demontarea containerului de depozitare

1. Trageți în afară containerul de depozitare atât cât este posibil.
2. 1. Ridicați containerul de depozitare de partea din față (1).
2. Scoateți containerul (2).

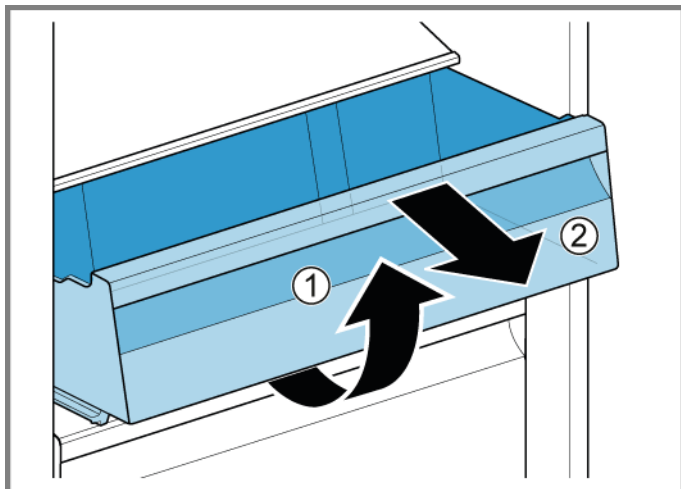

- ➔ Containerul de depozitare este demontat.

4.10.2 Montarea containerului de depozitare

- ▶ Montați urmând procedura de demontare în ordine inversă.

4.11 Repoziționarea containerului pentru fructe și legume

Cerință:

- ✓ Ușa este deschisă.

4.11.1 Demontarea containerului pentru fructe și legume

1. Trageți în afară containerul pentru fructe și legume atât cât este posibil.
2. 1. Ridicați containerul pentru fructe și legume de partea din față (1).
2. Scoateți containerul (2).

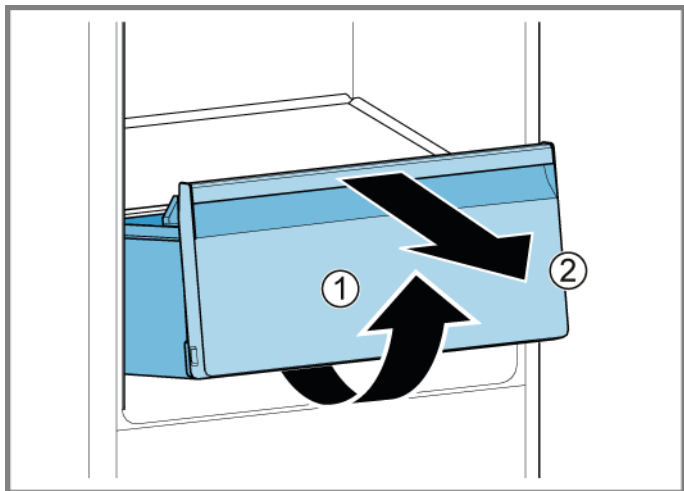

- ➔ Containerul pentru fructe și legume este demontat.

4.11.2 Montarea containerului pentru fructe și legume

- ▶ Montați urmând procedura de demontare în ordine inversă.

4.12 Repoziționarea raftului de deasupra containerului pentru fructe și legume

Cerință:

- ✓ Ușa este deschisă.
- ✓ [Containerul pentru fructe și legume este demontat.](#) →557

4.12.1 Demontarea raftului de deasupra containerului pentru fructe și legume

1. Împingeți în sus și în afară cadrul de etanșare.

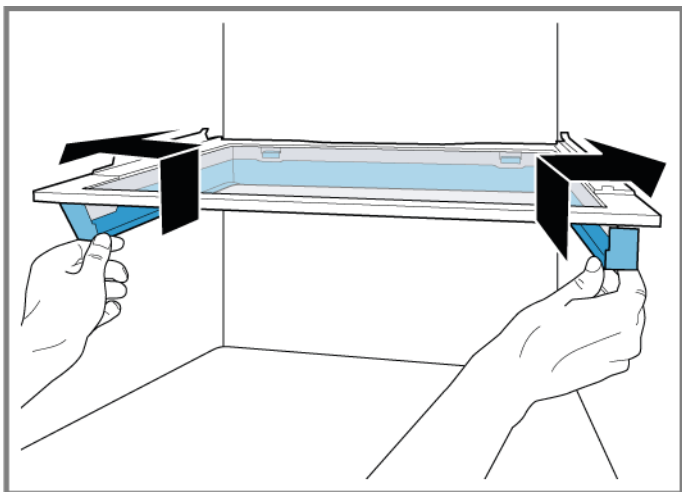

- ➡ Cârlițele laterale sunt decuplate.

2. Ridicați cadrul de etanșare și glisați-l invers.

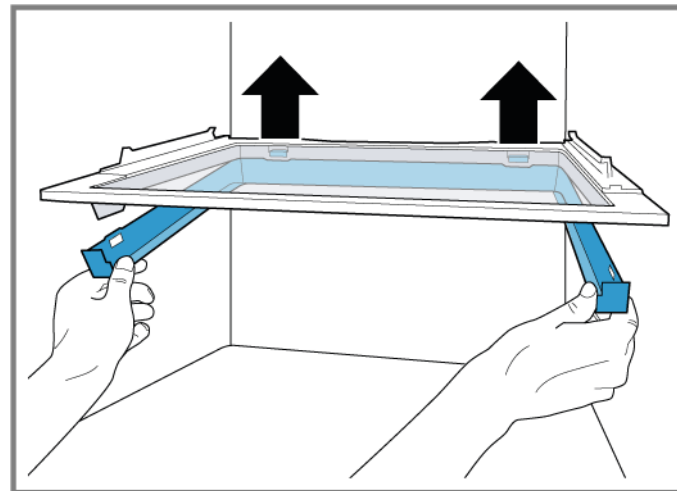

- ➡ Cârlițele din spate sunt decuplate.

3. Scoateți cadrul de etanșare.
4. Ridicați raftul de deasupra containerului pentru fructe și legume și scoateți-l răsucindu-l pe o parte.

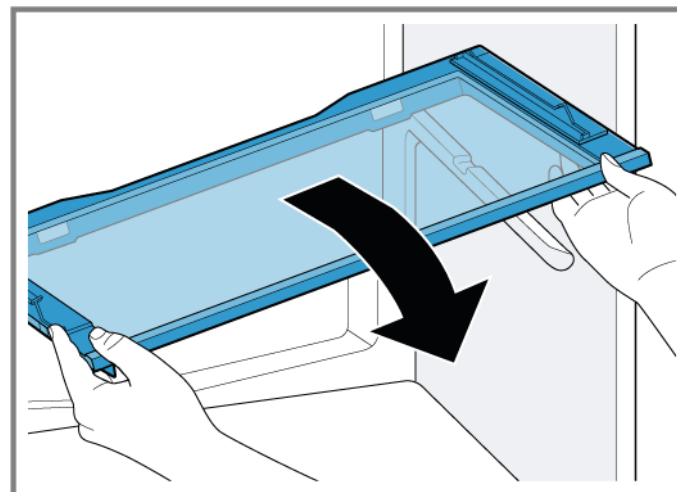

- ➡ Raftul de deasupra containerul pentru fructe și legume este demontat.

4.12.2 Montarea raftului de deasupra containerului pentru fructe și legume

- ▶ Montați urmând procedura de demontare în ordine inversă.

4.13 Repoziționarea containerului pentru alimente înghețate

Cerință:

- ✔ Ușa este deschisă.

4.13.1 Demontarea containerului pentru alimente înghețate

- ▶ 1. Extrageți complet containerul pentru alimente înghețate (1).
- ▶ 2. Demontați containerul pentru alimente (2).

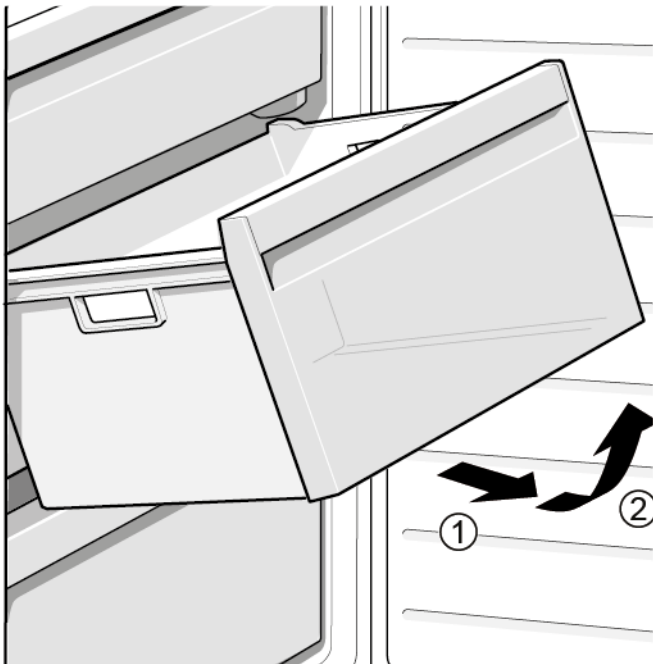

- ➡ Containerul pentru alimente înghețate este demontat.

4.13.2 Montarea containerului pentru alimente înghețate

- ▶ Montați urmând procedura de demontare în ordine inversă.

4.14 Înlocuirea lămpii LED de sus

Scule speciale:

 Instrument special

[00342180]



Aparatul dumneavoastră este echipat cu o lampă LED care nu necesită întreținere.
Aceste lămpi pot fi înlocuite numai de către departamentul de service pentru clienți sau de către tehnicieni autorizați!



PERICOL

Pericol de electrocutare din cauza pieselor sub tensiune!

Pericol de moarte prin electrocutare în cazul unei reparații necorespunzătoare

- ▶ Componentele electrice trebuie reparate de către electricieni calificați.
- ▶ După reparație, este obligatorie efectuarea unei verificări de siguranță conform cu VDE 0701 sau cu reglementările naționale respective.



PERICOL

Pericol de electrocutare din cauza pieselor sub tensiune!

Deces prin electrocutare

- ▶ Deconectați aparatele de la sursa de alimentare cu tensiune cu cel puțin 60 de secunde înainte de a începe reparațiile.





ATENȚIONARE

Marginea ascuțite!

Rănire prin tăiere

- ▶ Purtați mănuși de protecție.

Cerință:

-  Aparatul este deconectat de la sursa de energie electrică.
-  Ușa este deschisă.

4.14.1 Demontarea lămpii LED de sus

1. Glisați unealta de dezasamblare între lampa LED de sus și stratul intermediar al compartimentului frigiderului pentru a decupla cârligele lămpii (1).
2. Demontați lampa LED de sus (2).

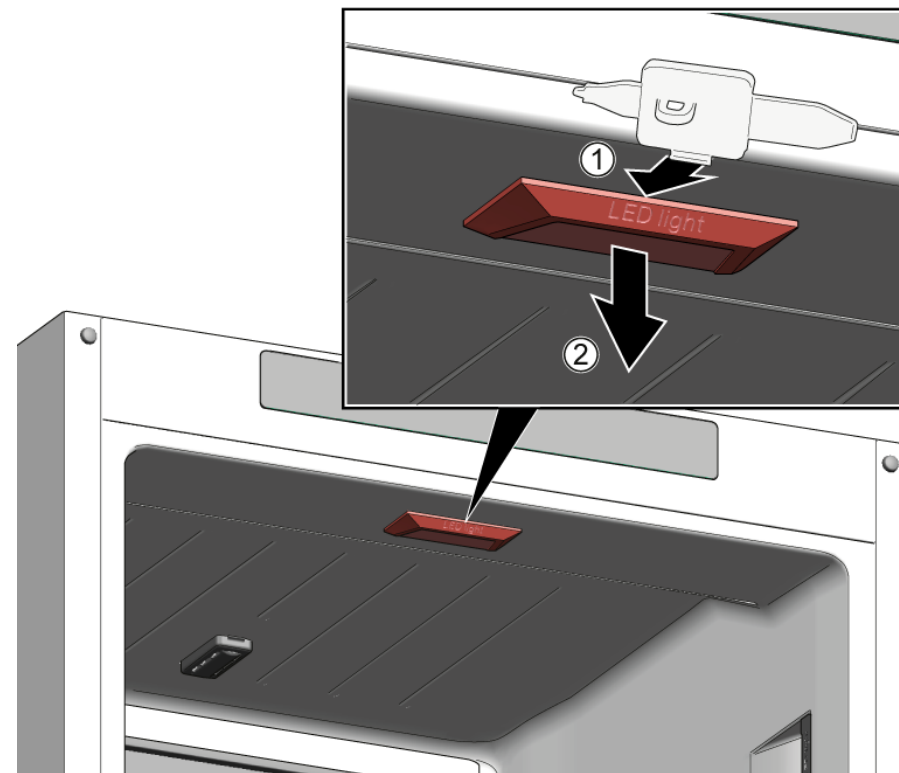

2. Deconectați conexiunea electrică a lămpii LED de sus.
-  Lampa LED de sus este demontată.

4.14.2 Montarea lămpii LED de sus

- ▶ Montați urmând procedura de demontare în ordine inversă.

4.15 Înlocuirea lămpii LED laterale

Scule speciale:

 Instrument special [00342180]

	<p>Aparatul dumneavoastră este echipat cu o lampă LED care nu necesită întreținere.</p> <p>Aceste lămpi pot fi înlocuite numai de către departamentul de service pentru clienți sau de către tehnicieni autorizați!</p>
---	---



	<p>⚠ PERICOL</p> <p>Pericol de electrocutare din cauza pieselor sub tensiune! Pericol de moarte prin electrocutare în cazul unei reparații necorespunzătoare</p> <ul style="list-style-type: none">▶ Componentele electrice trebuie reparate de către electricieni calificați.▶ După reparație, este obligatorie efectuarea unei verificări de siguranță conform cu VDE 0701 sau cu reglementările naționale respective.
--	---

	<p>⚠ PERICOL</p> <p>Pericol de electrocutare din cauza pieselor sub tensiune! Deces prin electrocutare</p> <ul style="list-style-type: none">▶ Deconectați aparatele de la sursa de alimentare cu tensiune cu cel puțin 60 de secunde înainte de a începe reparațiile.
--	--

	<p>⚠ ATENȚIONARE</p> <p>Marginea ascuțite! Rănire prin tăiere</p> <ul style="list-style-type: none">▶ Purtați mănuși de protecție.
--	--

	<p>ATENȚIE!</p> <p>Pericol de deteriorare a componentelor sensibile la electricitatea statică (ESD)! Deteriorarea componentelor</p> <ul style="list-style-type: none">▶ Înainte de a începe lucrul la componentele sensibile la electricitatea statică, folosiți un sistem de protecție împotriva electricității statice (o brățară cu împământare).▶ Nu atingeți conexiunile și căile conductorilor de la module.▶ Transportați componentele sensibile la electricitatea statică numai în materiale conductoare sau în ambalajul original.▶ Păstrați aceste componente departe de materiale care s-ar putea descărca electrostatic (adică plastic).
---	---

Cerință:

-  Aparatul este deconectat de la sursa de energie electrică.
-  Ușa este deschisă.
-  Fitingurile interioare RC sunt demontate.

4.15.1 Demontarea lămpii LED laterale

1. Glisați unealta de dezasamblare între difuzorul lămpii și carcasă pentru a elibera cârligul (1).
2. Scoateți difuzorul lămpii (2).
3. Eliberați următoarele cârlige de fixare ale difuzorului urmând aceeași procedură.

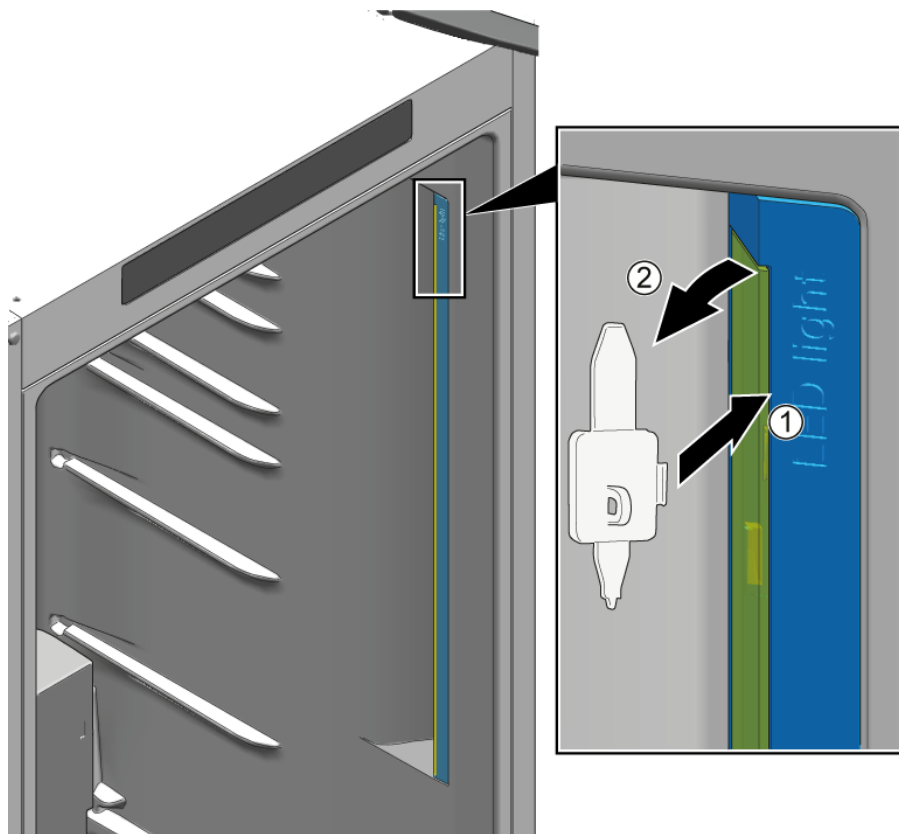

 Difuzorul lămpii este demontat.

2. 1. Apăsați pe cârligul de fixare pentru a-l elibera (1).
2. Mutați modulul LED în sus aproximativ 1 cm pentru a-l scoate din priză (2).
3. Demontați modulul LED (3).

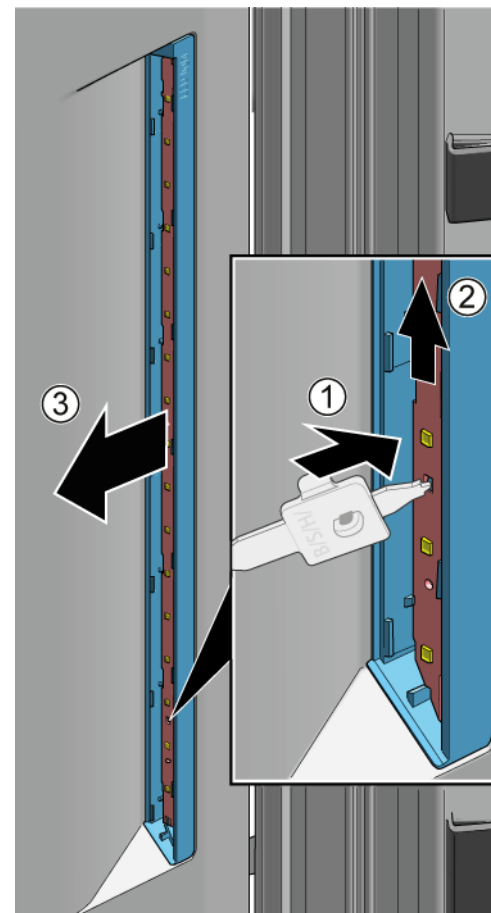

 Lampa LED laterală este demontată.

4.15.2 Montarea lămpii LED laterale



Deoarece cârligele difuzorului lămpii se pot sparge ușor în timpul procesului de demontare, lampa LED laterală de schimb este un set care include modulul LED și difuzorul lămpii.

Repararea

1. Glisați unealta de dezasamblare între difuzorul lămpii și carcasă pentru a elibera cârligul (1).
2. Scoateți difuzorul lămpii (2).
3. Eliberați următoarele cârlige de fixare ale difuzorului urmând aceeași procedură.

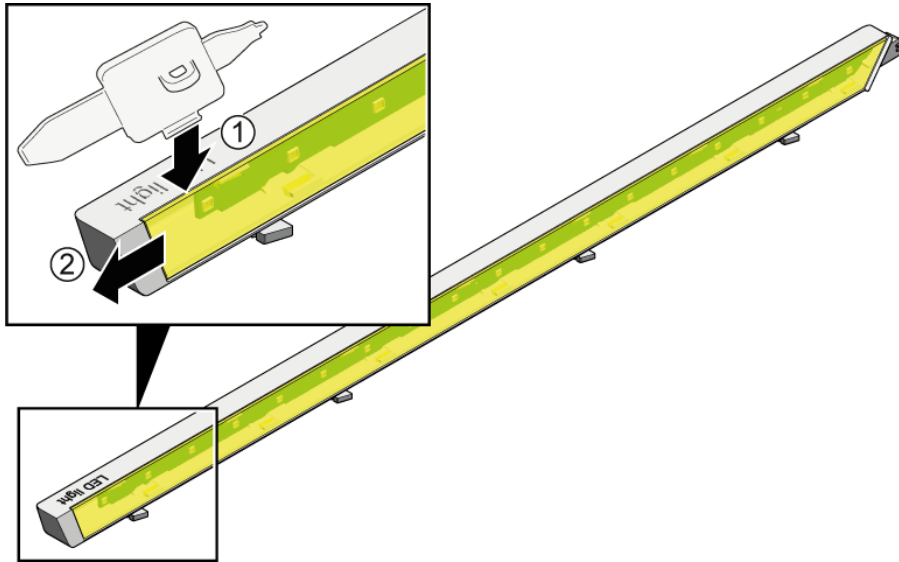

2. 1. Apăsați pe cârligul de fixare pentru a-l elibera (1).
2. Glisați modulul LED în sus pentru a-l scoate din carcasă.
3. Îndepărtați carcasa modulului LED care este folosită pentru transportarea pieselor de schimb din motive de siguranță (3).

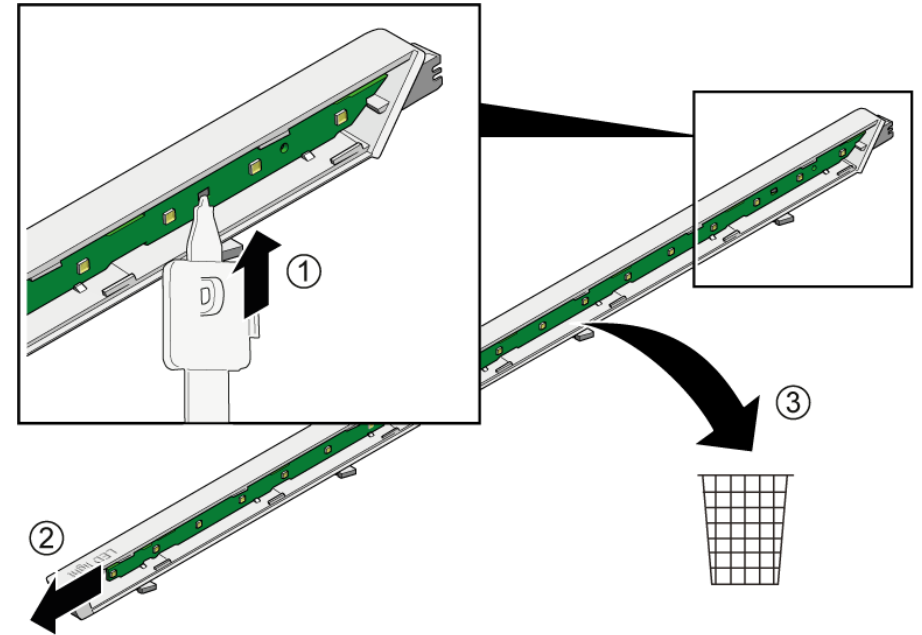



3. Montați modulul LED și difuzorul lămpii urmând procedura de demontare în ordine inversă.

4.16 Înlocuirea lămpii LED din congelator

Scule speciale:

🔧 Instrument special [00342180]

	<p>Aparatul dumneavoastră este echipat cu o lampă LED care nu necesită întreținere.</p> <p>Aceste lămpi pot fi înlocuite numai de către departamentul de service pentru clienți sau de către tehnicieni autorizați!</p>
---	---

	<p style="text-align: center;">⚠️ PERICOL</p> <p>Pericol de electrocutare din cauza pieselor sub tensiune! Pericol de moarte prin electrocutare în cazul unei reparații necorespunzătoare</p> <ul style="list-style-type: none">▶ Componentele electrice trebuie reparate de către electricieni calificați.▶ După reparație, este obligatorie efectuarea unei verificări de siguranță conform cu VDE 0701 sau cu reglementările naționale respective.
--	--

	<p style="text-align: center;">⚠️ PERICOL</p> <p>Pericol de electrocutare din cauza pieselor sub tensiune! Deces prin electrocutare</p> <ul style="list-style-type: none">▶ Deconectați aparatele de la sursa de alimentare cu tensiune cu cel puțin 60 de secunde înainte de a începe reparațiile.
--	---

	<p style="text-align: center;">⚠️ ATENȚIONARE</p> <p>Marginea ascuțite! Rănire prin tăiere</p> <ul style="list-style-type: none">▶ Purtați mănuși de protecție.
--	---

Cerință:

- ✔ Aparatul este deconectat de la sursa de energie electrică.
- ✔ Ușa este deschisă.

4.16.1 Demontarea lămpii LED din congelator

- ▶ 1. Glisați unealta de dezasamblare între lampă și carcasa din partea laterală a lămpii pentru a crea un spațiu liber (1).
- ▶ 2. Glisați unealta de dezasamblare pe cârligul de fixare din partea cealaltă a lămpii și rotiți-l înainte (2).
- ▶ 3. Demontați lampa LED din congelator (3).

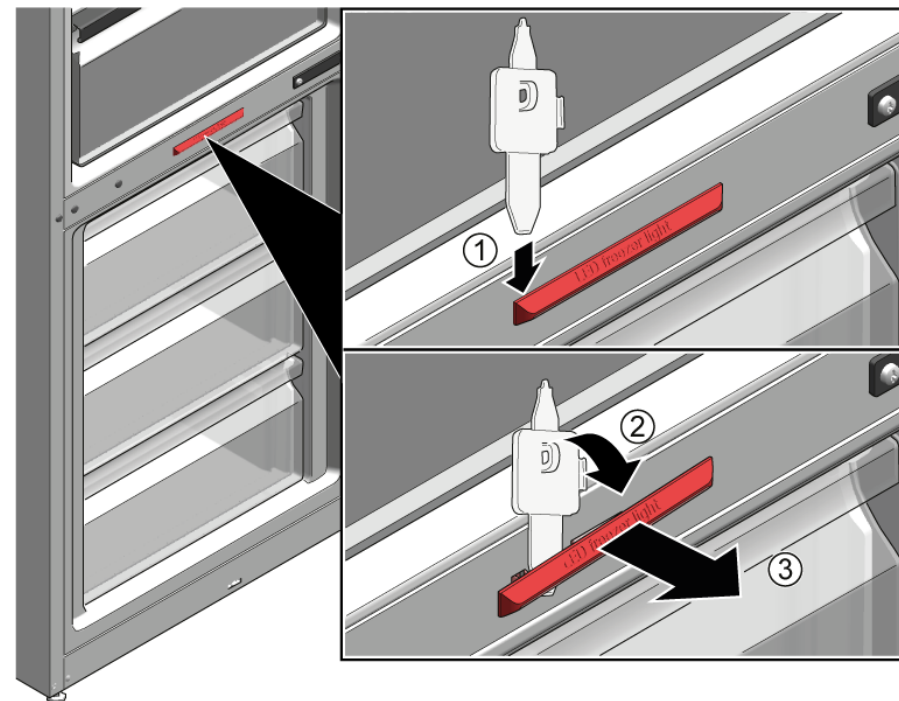





- ➡ Lampa LED din congelator este deconectată.
- ➡ Lampa LED din congelator este demontată.

4.16.2 Montarea lămpii LED din congelator

- ▶ Montați urmând procedura de demontare în ordine inversă.

Poznámky k opravám - Kombinácia chladničky a mrazničky

 O tomto dokumente	567		
1.1 Dôležité informácie	567		
1.1.1 Účel	567		
1.2 Vysvetlenie symbolov	567		
1.2.1 Úrovne nebezpečenstva	567		
1.2.2 Symboly označujúce riziká	567		
1.2.3 Štruktúra varovaní	568		
1.2.4 Všeobecné symboly	568		
 Bezpečnosť	569		
2.1 Všeobecné bezpečnostné pokyny	569		
2.1.1 Všetky domáce spotrebiče	569		
 Nástroje a pomôcky	570		
 Oprava	571		
4.1 Výmena tesnenia dvierok	571		
4.1.1 Odoberanie tesnenia dvierok	571		
4.1.2 Montáž tesnenia dvierok	571		
4.2 Výmena dverovej úchytky	574		
4.2.1 Odoberanie dverovej úchytky	574		
4.2.2 Montáž dverovej úchytky	574		
4.3 Výmena horného závesu dverí	575		
4.3.1 Odoberanie horného závesu dvierok	575		
4.3.2 Montáž horného závesu dvierok	576		
4.4 Výmena horného závesu dvierok (dvierka s displejom)	577		
4.4.1 Odoberanie horného závesu dvierok	578		
4.4.2 Montáž horného závesu dvierok	579		
4.5 Výmena prostredného závesu dverí	580		
4.5.1 Odoberanie prostredného závesu dverí	580		
4.5.2 Montáž prostredného závesu dverí	581		
4.6 Výmena spodného závesu dvierok	582		
4.6.1 Odoberanie spodného závesu dverí	582		
4.6.2 Montáž spodného závesu dvierok	582		
4.7 Výmena odkladacej plochy	583		
4.7.1 Odoberanie odkladacej plochy	583		
4.7.2 Montáž odkladacej plochy	583		
4.8 Výmena odkladacieho priestoru na fľaše	584		
4.8.1 Odoberanie odkladacieho priestoru na fľaše	584		
4.8.2 Montáž odkladacieho priestoru na fľaše	584		
4.9 Výmena poličky v dvierkach	585		
4.9.1 Odoberanie poličky v dvierkach	585		
4.9.2 Montáž poličky do dvierok	585		
4.10 Výmena úložnej nádoby	586		
4.10.1 Odoberanie úložnej nádoby	586		
4.10.2 Montáž úložnej nádoby	586		
4.11 Výmena nádoby na ovocie a zeleninu	587		
4.11.1 Odoberanie nádoby na ovocie a zeleninu	587		
4.11.2 Montáž nádoby na ovocie a zeleninu	587		
4.12 Výmena odkladacej plochy nad nádobou na ovocie a zeleninu	588		
4.12.1 Odoberanie odkladacej plochy nad nádobou na ovocie a zeleninu	588		
4.12.2 Montáž odkladacej plochy nad nádobu na ovocie a zeleninu	589		
4.13 Výmena nádoby na zmrazené potraviny	590		
4.13.1 Odoberanie nádoby na zmrazené potraviny	590		
4.13.2 Montáž nádoby na zmrazené potraviny	590		
4.14 Výmena hornej LED žiarovky	591		
4.14.1 Odoberanie hornej LED žiarovky	591		
4.14.2 Montáž hornej LED žiarovky	591		
4.15 Výmena bočnej LED žiarovky	592		
4.15.1 Odoberanie bočnej LED žiarovky	592		
4.15.2 Montáž bočnej LED žiarovky	593		
4.16 Výmena LED žiarovky v mrazničke	595		
4.16.1 Odoberanie LED žiarovky v mrazničke	595		
4.16.2 Montáž LED žiarovky v mrazničke	595		

i O tomto dokumente

1.1 Dôležité informácie

1.1.1 Účel

Tieto pokyny pre opravu pomáhajú spotrebiteľovi pri vlastnej oprave spotrebičov podľa nariadenia o ekodizajne (z marca 2021).

Obsahujú informácie o výmene určených náhradných dielov vrátane varovaní a rizík.

Ak máte otázky, kontaktujte náš zákaznicky servis. Za poškodenia ručíme len vtedy, ak pokyny boli dodržané správne.

1.2 Vysvetlenie symbolov

1.2.1 Úrovne nebezpečenstva

Úroveň varovania obsahuje symbol a signalizačné slovo. Signalizačné slovo naznačuje mieru nebezpečenstva.





Úroveň varovania	Význam
 NEBEZPEČENSTVO	Následkom nerešpektovania varovného hlásenia je úmrtie alebo vážne zranenia.
 VAROVANIE	Možným následkom nerešpektovania varovného hlásenia je úmrtie alebo vážne zranenia.
 UPOZORNENIE	Možným následkom nerešpektovania varovného hlásenia sú mierne zranenia.
 POZOR!	Možným následkom nerešpektovania varovného hlásenia je poškodenie majetku.

Tabuľka 1: Úrovne nebezpečenstva



1.2.2 Symboly označujúce riziká

Symboly označujúce riziká sú symbolické znázornenia, ktoré naznačujú druh nebezpečenstva.

V tomto dokumente sa používajú nasledujúce symboly označujúce riziká:

Symbol označujúci riziko	Význam
	Všeobecné varovné hlásenie
	Nebezpečenstvo v súvislosti s elektrickým napätím
	Nebezpečenstvo výbuchu
	Nebezpečenstvo porezania
	Nebezpečenstvo pomliaždenia

i O tomto dokumente

Symbol označujúci riziko	Význam
	Nebezpečenstvo v súvislosti s horúcimi povrchmi
	Nebezpečenstvo v súvislosti s magnetickým poľom
	Nebezpečenstvo v súvislosti s neionizujúcou radiáciou

Tabuľka 2: Symboly označujúce riziká

1.2.3 Štruktúra varovaní

Varovania v tomto dokumente majú štandardný vzhľad a štandardnú štruktúru.



	<p>⚠ NEBEZPEČENSTVO</p> <p>Druh a zdroj nebezpečenstva! Možné následky pri ignorovaní nebezpečenstva/varovania.</p> <ul style="list-style-type: none"> ▶ Opatrenia a zákazy na zabránenie nebezpečenstvu.
--	--





Nasledujúci príklad znázorňuje varovanie pred zásahom elektrickým prúdom pri dotyku s časťami pod napätím. Je uvedené opatrenie na predídenie nebezpečenstvu.

	<p>⚠ NEBEZPEČENSTVO</p> <p>Nebezpečenstvo úrazu elektrickým prúdom pri dotyku s časťami pod napätím! Úmrtie v dôsledku zásahu elektrickým prúdom</p> <ul style="list-style-type: none"> ▶ Odpojte spotrebiče od elektrického zdroja aspoň 60 sekúnd pred začiatkom opráv.
---	--

1.2.4 Všeobecné symboly

V tomto dokumente sa používajú nasledujúce všeobecné symboly:

Všeob. symbol	Význam
	Označenie špeciálneho pokynu (textové a/alebo grafické)
	Označenie jednoduchého pokynu (len textové)

Všeob. symbol	Význam
	Označenie prepojenia na videonávod
	Označenie požadovaných nástrojov
	Označenie požadovaných podmienok
	Označenie podmienky (ak ..., potom ...)
	Označenie výsledku
[Spustenie]	Označenie klávesu alebo tlačidla
[00123456]	Označenie čísla materiálu
Stav	Označenie zobrazeného textu/okna (na displeji spotrebiča)

Tabuľka 3: Všeobecné symboly

2.1 Všeobecné bezpečnostné pokyny

2.1.1 Všetky domáce spotrebiče

Nebezpečenstvo úrazu elektrickým prúdom pri dotyku s časťami pod napätím!

- Chyby pri opravách na elektrických komponentoch môžu spôsobiť zásah elektrickým prúdom!
- Odpojte spotrebič od elektrickej siete aspoň 60 sekúnd pred začiatkom práce.
- Po oprave zariadenia vykonajte bezpečnostný test v súlade s nariadením VDE 0701 alebo s miestnymi nariadeniami.

Riziko poranenia na ostrých hranách!

- Noste ochranné rukavice.

Riziko pomliaždenia počas opravy, údržby, riešenia problémov a servisu na ťažkých a pohybujúcich sa komponentoch

- Noste ochrannú obuv.
- Zaisťte ťažké komponenty proti pádu.
- Nesiahajte končatinami do pohybujúcich sa komponentov.

Riziko ohrozenia bezpečnosti/funkčnosti spotrebiča!

- Používajte len originálne náhradné diely.

Riziko poškodenia elektrostaticky citlivých komponentov (ESD)!

- Nedotýkajte sa modulov vrátane prípojok a vedení vodičov.

Nástroje a pomôcky

Označenie	Detaily	Snímky
Bit Torx TX20 [00340865]	6,3 mm (1/4")	
Špeciálny nástroj [00342180]		

4.1 Výmena tesnenia dvierok

Požiadavka:

- ✔ Dvierka sú otvorené.

4.1.1 Odoberanie tesnenia dvierok

1. Uvoľnite tesnenie dvierok z drážky na pravom a ľavom rohu.



2. Vytiahnite tesnenie z drážky.



- ➡ Tesnenie dvierok je odobraté.

4.1.2 Montáž tesnenia dvierok



Hrúbka nového tesnenia dvierok sa môže mierne odlišovať od hrúbky starého tesnenia dvierok. Neovplyvní to zatváranie ani funkčnosť z dlhodobého hľadiska.

Ak má váš spotrebič nastaviteľné závesy alebo závesové úchytky, postupne môžete optimalizovať spôsob zatvárania.

Malé bočné dierky v tesnení dvierok majú svoju funkciu (sú potrebné na vetranie). Nie sú výrobnu chybou.

1. Skontrolujte poškodenie drážky na tesnenie.



4. Hore a dole vtláčte rohy tesnenia do drážky.

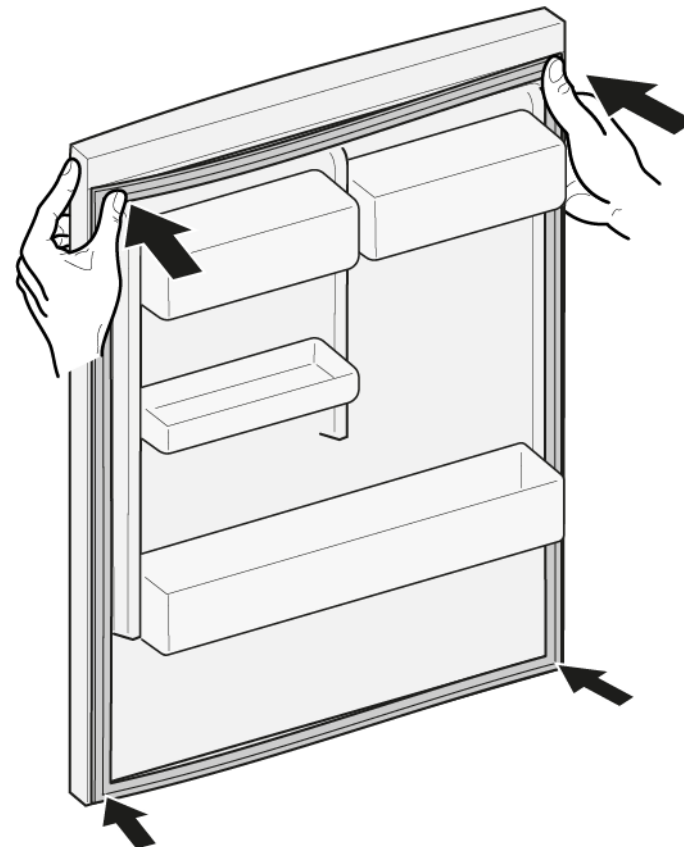

2.  Ak je drážka tesnenia je poškodená.
- Kontaktujte zákaznícky servis.

3.  Mierna deformácia tesnenia dvierok je normálna a neovplyvňuje jeho funkciu. Odporúča sa vyrovnať tesnenie pred jeho vloženíím do spotrebiča.

Nahrejte tesnenie dvierok použitím fénu alebo horúcej vody a manuálne ho vytvarujte.

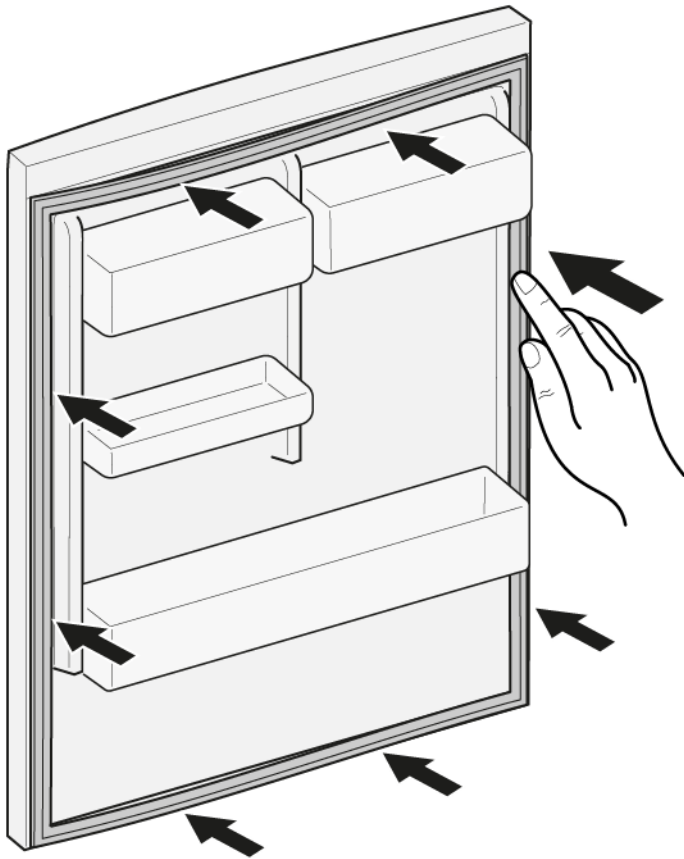

5. Jedno miesto po druhom vtlačte celé tesnenie do drážky.





-  Tesnenie dvierok je namontované.

4.2 Výmena dverovej úchytky

Špeciálne nástroje:

-  Bit Torx TX20 6,3 mm (1/4") [00340865]
-  Plochý skrutkovač Čepel' 10 mm x 1,6 mm x 200 mm

Požiadavka:

-  Spotrebič je odpojený od elektrického napájania.
-  Dvierka sú otvorené.

4.2.1 Odoberanie dverovej úchytky

- ▶ 1. Odoberte dve krytky skrutiek (1).
- ▶ 2. Odskrutkujte dve skrutky (2).
- ▶ 3. Odoberte dverovú úchytку (3).

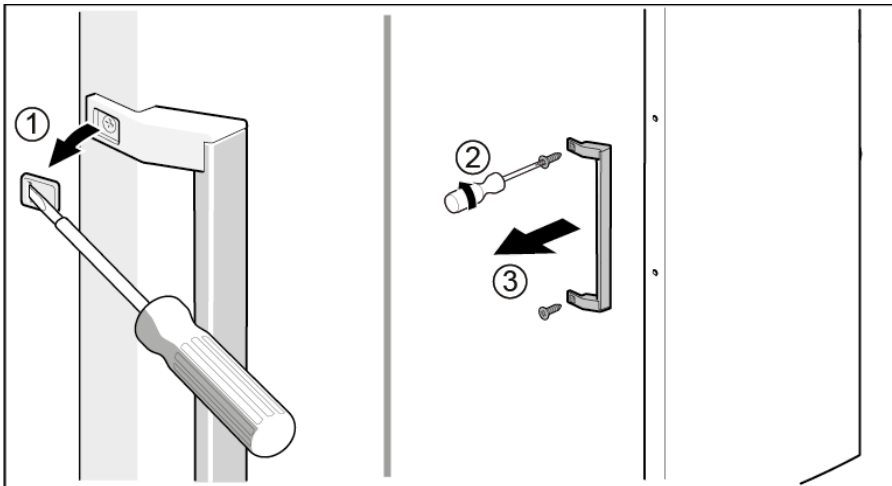

 Dverová úchytka je odobratá.



Dverová úchytka druhých dvierok sa dá odobrať rovnakým spôsobom.

4.2.2 Montáž dverovej úchytky

- ▶ Pri montáži postupujte v opačnom poradí krokov demontáže.

4.3 Výmena horného závesu dverí

Špeciálne nástroje:

 Bit Torx TX20 6,3 mm (1/4") [00340865]

	<p>VAROVANIE</p> <p>Ťažké, objemné spotrebiče! Poranenie chrbta a svalov</p> <ul style="list-style-type: none"> ▶ Proces odobrania dvierok spotrebiča by mal vykonávať školený odborník. ▶ Na presunutie spotrebiča sa vyžadujú dve osoby. ▶ Použite vhodné nástroje a vybavenie.
--	--



	<p>UPOZORNENIE</p> <p>Ostré hrany! Rezné poranenia</p> <ul style="list-style-type: none"> ▶ Noste ochranné rukavice.
--	---

	<p>VAROVANIE</p> <p>Zošmyknutie naklonených spotrebičov! Zlomeniny/pomliaždenia</p> <ul style="list-style-type: none"> ▶ Zaistite spotrebiče proti zošmyknutiu.
--	--

	<p>UPOZORNENIE</p> <p>Riziko pádu dielov po uvoľnení skrutiek! Zranenie padajúcimi dielmi.</p> <ul style="list-style-type: none"> ▶ Zaistite komponent proti pádu.
---	---

	<p>POZOR!</p> <p>Riziko pádu dielov po uvoľnení skrutiek! Poškodenie iných častí spotrebiča alebo domácnosti zákazníka, napr. podlahy.</p> <ul style="list-style-type: none"> ▶ Zaistite komponent proti pádu.
--	---

Požiadavka:

-  Spotrebič je odpojený od elektrického napájania.
-  Tvarovky z interiéru spotrebiča sú odobraté.

4.3.1 Odoberanie horného závesu dvierok

1. Posuňte nosnú časť pod základnú časť.

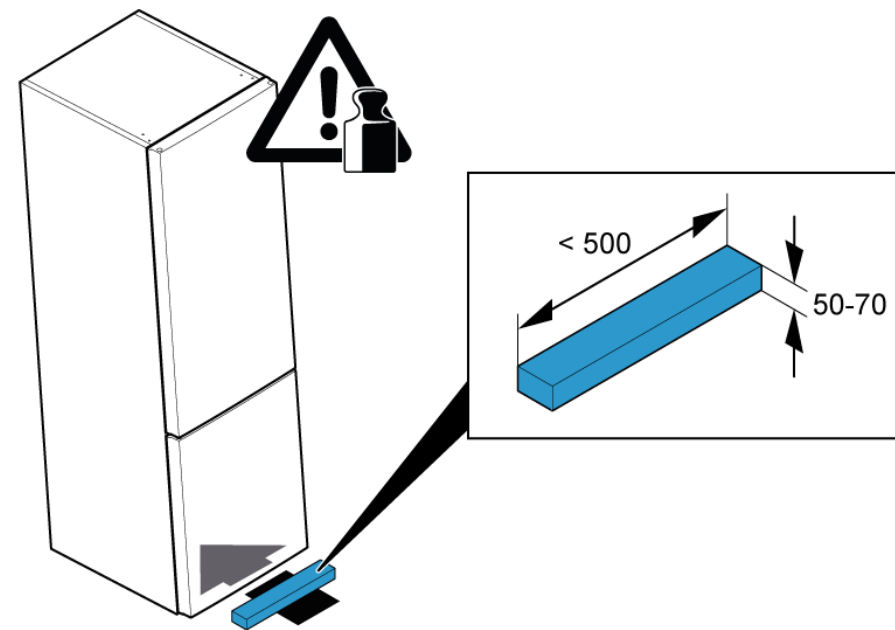

2. 1. Odoberte kryt horného závesu (1).
2. Odskrutkujte dve skrutky (2).
3. Odoberte horný záves (3).

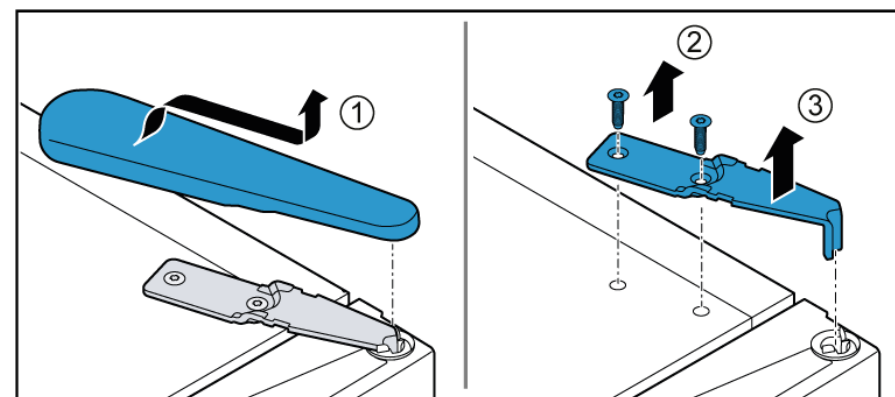

3. Odoberte horné dvierka.

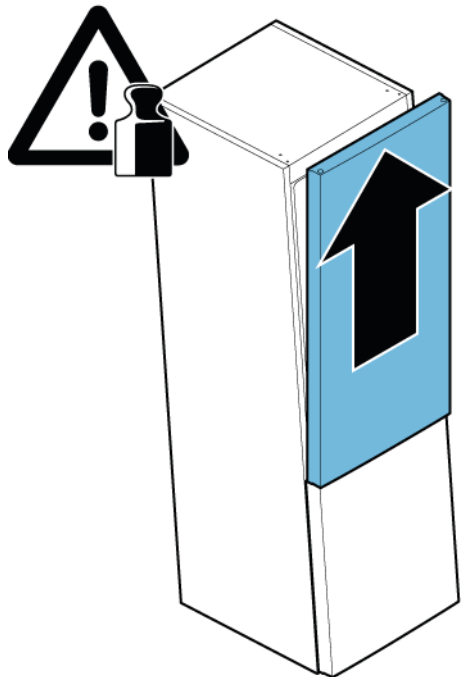

 Horný záves je odobratý.

4.3.2 Montáž horného závesu dvierok

► Pri montáži postupujte v opačnom poradí krokov demontáže.

4.4 Výmena horného závesu dvierok (dvierka s displejom)

Špeciálne nástroje:

 Bit Torx TX20 6,3 mm (1/4") [00340865]

	VAROVANIE
	<p>Ťažké, objemné spotrebiče! Poranenie chrbta a svalov</p> <ul style="list-style-type: none"> ▶ Proces odoberania dvierok spotrebiča by mal vykonávať školený odborník. ▶ Na presunutie spotrebiča sa vyžadujú dve osoby. ▶ Použite vhodné nástroje a vybavenie.

	UPOZORNENIE
	<p>Ostré hrany! Rezné poranenia</p> <ul style="list-style-type: none"> ▶ Noste ochranné rukavice.

	VAROVANIE
	<p>Zošmyknutie naklonených spotrebičov! Zlomeniny/pomliaždenia</p> <ul style="list-style-type: none"> ▶ Zaistite spotrebiče proti zošmyknutiu.



	UPOZORNENIE
	<p>Riziko pádu dielov po uvoľnení skrutiek! Zranenie padajúcimi dielmi.</p> <ul style="list-style-type: none"> ▶ Zaistite komponent proti pádu.

	POZOR!
	<p>Riziko pádu dielov po uvoľnení skrutiek! Poškodenie iných častí spotrebiča alebo domácnosti zákazníka, napr. podlahy.</p> <ul style="list-style-type: none"> ▶ Zaistite komponent proti pádu.

	NEBEZPEČENSTVO
	<p>Nebezpečenstvo úrazu elektrickým prúdom pri dotyku s časťami pod napätím! Ohrozenie života spôsobené elektrickým zásahom v prípade nesprávnej opravy</p> <ul style="list-style-type: none"> ▶ Elektrické diely má opravovať kvalifikovaný elektrikár. ▶ Po oprave zariadte vykonanie bezpečnostného testu v súlade s nariadením VDE 0701 alebo s miestnymi nariadeniami.

	NEBEZPEČENSTVO
	<p>Nebezpečenstvo úrazu elektrickým prúdom pri dotyku s časťami pod napätím! Úmrtie v dôsledku zásahu elektrickým prúdom</p> <ul style="list-style-type: none"> ▶ Odpojte spotrebiče od elektrického zdroja aspoň 60 sekúnd pred začiatkom opráv.

Požiadavka:

-  Spotrebič je odpojený od elektrického napájania.
-  Tvarovky z interiéru spotrebiča sú odobraté.

4.4.1 Odoberanie horného závesu dvierok

1. Posuňte nosnú časť pod základnú časť.

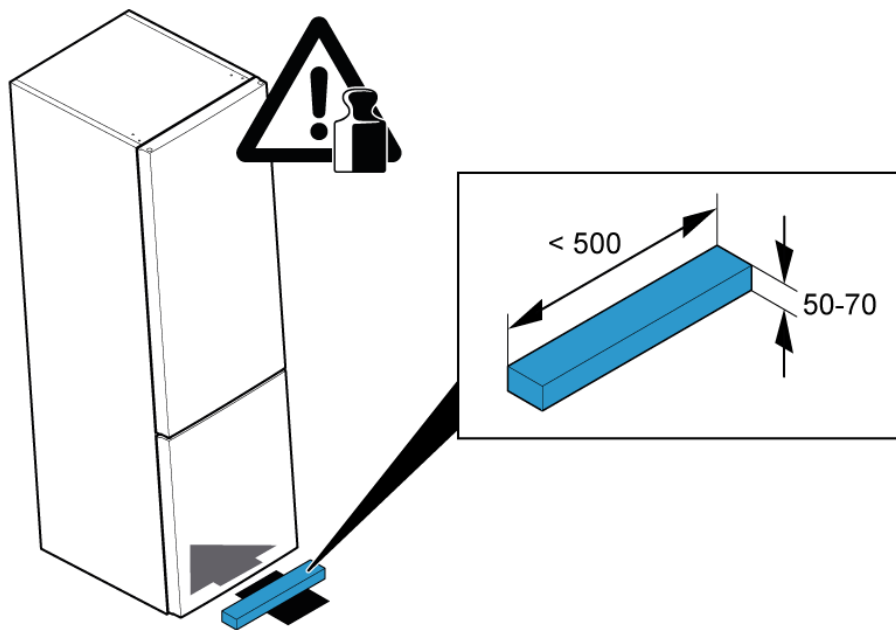

2. 1. Odoberte kryt horného závesu (1).
2. Odpojte elektrické pripojenie (2).
3. Odskrutkujte skrutku uzemňovacieho pripojenia (3).

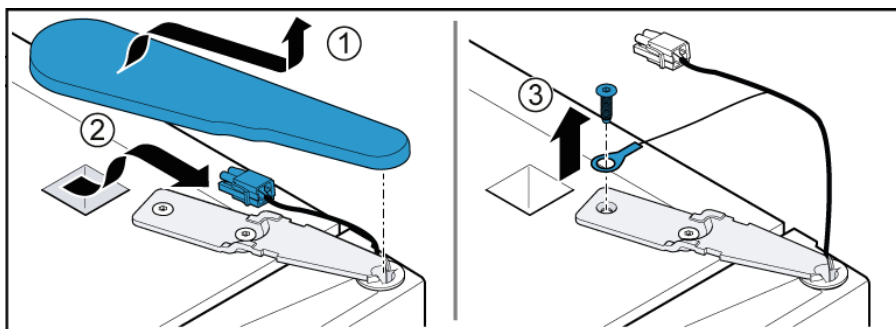

3. 1. Odskrutkujte skrutku (1).
2. Odoberte horný záves (2).

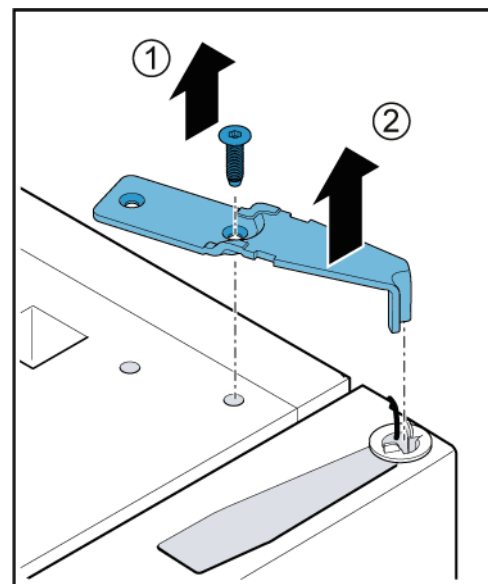

4. Odoberte horné dvierka.

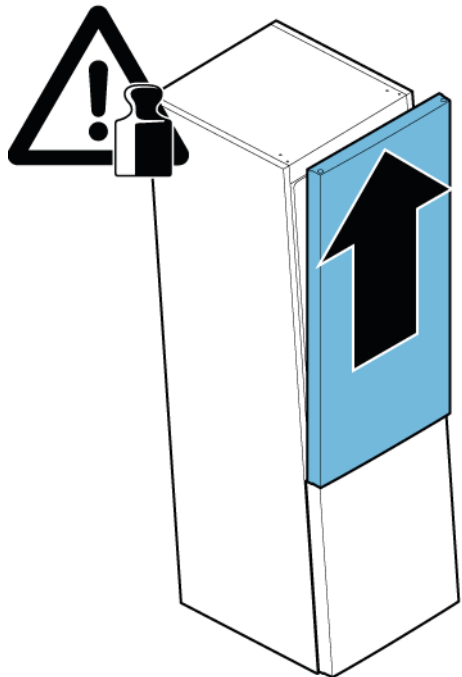

 Horný záves je odobratý.

4.4.2 Montáž horného závesu dvierok

- ▶ Pri montáži postupujte v opačnom poradí krokov demontáže.

4.5 Výmena prostredného závesu dverí

Špeciálne nástroje:

 Bit Torx TX20 6,3 mm (1/4") [00340865]

	VAROVANIE
	<p>Ťažké, objemné spotrebiče! Poranenie chrbta a svalov</p> <ul style="list-style-type: none"> ▶ Proces odobrania dverí spotrebiča by mal vykonávať školený odborník. ▶ Na presunutie spotrebiča sa vyžadujú dve osoby. ▶ Použite vhodné nástroje a vybavenie.



	UPOZORNENIE
	<p>Ostré hrany! Rezné poranenia</p> <ul style="list-style-type: none"> ▶ Noste ochranné rukavice.

	VAROVANIE
	<p>Zošmyknutie naklonených spotrebičov! Zlomeniny/pomliaždenia</p> <ul style="list-style-type: none"> ▶ Zaistite spotrebiče proti zošmyknutiu.

	UPOZORNENIE
	<p>Riziko pádu dielov po uvoľnení skrutiek! Zranenie padajúcimi dielmi.</p> <ul style="list-style-type: none"> ▶ Zaistite komponent proti pádu.

	POZOR!
	<p>Riziko pádu dielov po uvoľnení skrutiek! Poškodenie iných častí spotrebiča alebo domácnosti zákazníka, napr. podlahy.</p> <ul style="list-style-type: none"> ▶ Zaistite komponent proti pádu.

Požiadavka:

-  Spotrebič je odpojený od elektrického napájania.
-  Tvarovky z interiéru spotrebiča sú odobraté.
-  Horný záves dverí je odobratý.

-  Horné dverka sú odobraté.

4.5.1 Odoberanie prostredného závesu dverí

1. 1. Odskrutkujte dve skrutky (1).
2. 2. Odoberte prostredný záves (2).

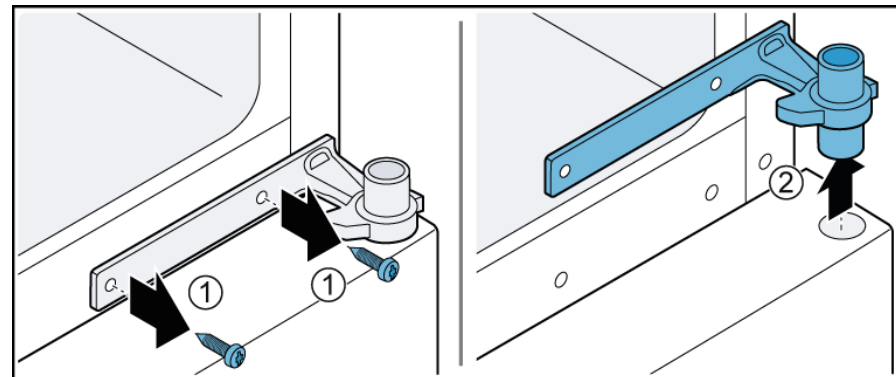

2. Odoberte spodné dvierka.

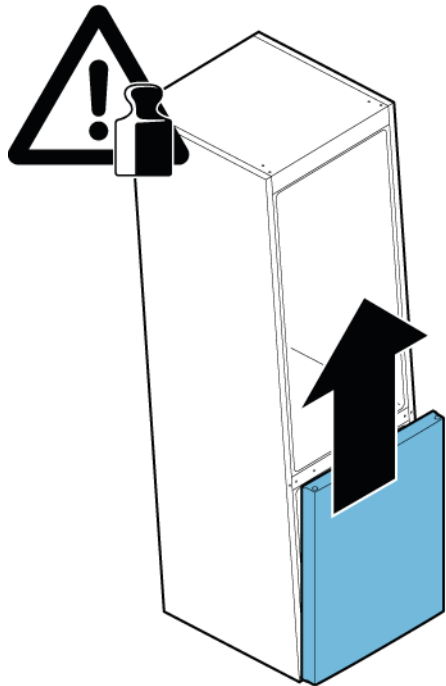

➡ Prostredný záves je odobratý.

4.5.2 Montáž prostredného závesu dverí

- ▶ Pri montáži postupujte v opačnom poradí krokov demontáže.

4.6 Výmena spodného závesu dvierok

Špeciálne nástroje:

 Bit Torx TX20 6,3 mm (1/4") [00340865]

	VAROVANIE
	<p>Ťažké, objemné spotrebiče! Poranenie chrbta a svalov</p> <ul style="list-style-type: none"> ▶ Proces odoberania dvierok spotrebiča by mal vykonávať školený odborník. ▶ Na presunutie spotrebiča sa vyžadujú dve osoby. ▶ Použite vhodné nástroje a vybavenie.



	UPOZORNENIE
	<p>Ostré hrany! Rezné poranenia</p> <ul style="list-style-type: none"> ▶ Noste ochranné rukavice.

	VAROVANIE
	<p>Zošmyknutie naklonených spotrebičov! Zlomeniny/pomliaždenia</p> <ul style="list-style-type: none"> ▶ Zaistite spotrebiče proti zošmyknutiu.

	UPOZORNENIE
	<p>Riziko pádu dielov po uvoľnení skrutiek! Zranenie padajúcimi dielmi.</p> <ul style="list-style-type: none"> ▶ Zaistite komponent proti pádu.

	POZOR!
	<p>Riziko pádu dielov po uvoľnení skrutiek! Poškodenie iných častí spotrebiča alebo domácnosti zákazníka, napr. podlahy.</p> <ul style="list-style-type: none"> ▶ Zaistite komponent proti pádu.

Požiadavka:

-  Spotrebič je odpojený od elektrického napájania.
-  Tvarovky z interiéru spotrebiča sú odobraté.
-  Horný záves je odobratý.

-  Prostredný záves je odobratý.

4.6.1 Odoberanie spodného závesu dverí

- ▶ 1. Odskrutkujte dve skrutky (1).
- ▶ 2. Odoberte spodný záves (2).

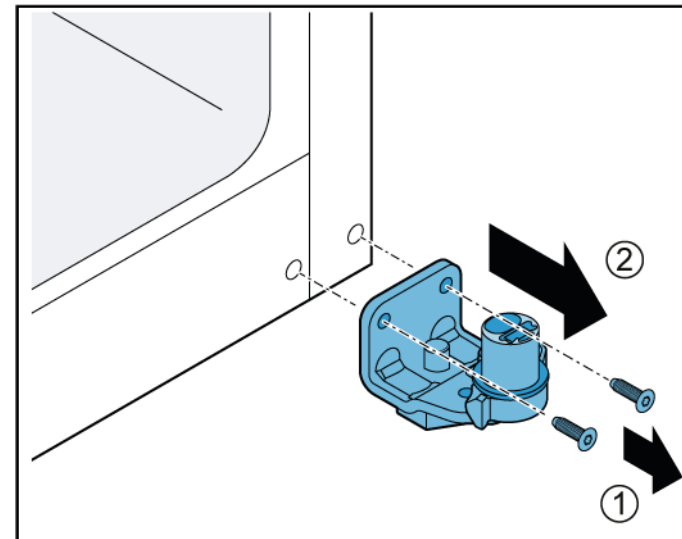

-  Spodný záves dverí je odobratý.

4.6.2 Montáž spodného závesu dverí

- ▶ Pri montáži postupujte v opačnom poradí krokov demontáže.

4.7 Výmena odkladacej plochy

Požiadavka:

- ✔ Dvierka sú otvorené.

4.7.1 Odoberanie odkladacej plochy

- ▶ 1. Nadvihnite odkladaciu plochu za zadnú časť (1).
- ▶ 2. Uvoľnite odkladaciu plochu (2).

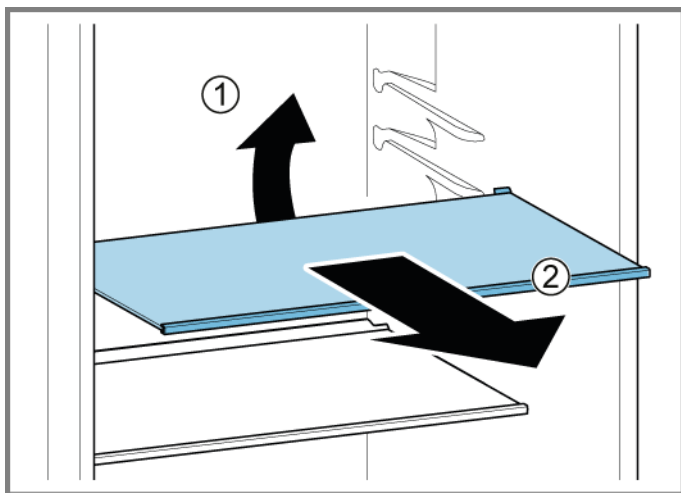

- ➡ Odkladacia plocha je odobratá.

4.7.2 Montáž odkladacej plochy

- ▶ Pri montáži postupujte v opačnom poradí krokov demontáže.

4.8 Výmena odkladacieho priestoru na fľaše

Požiadavka:

- ✔ Dvierka sú otvorené.

4.8.1 Odobratie odkladacieho priestoru na fľaše

- ▶ Vytiahnite odkladací priestor na fľaše.

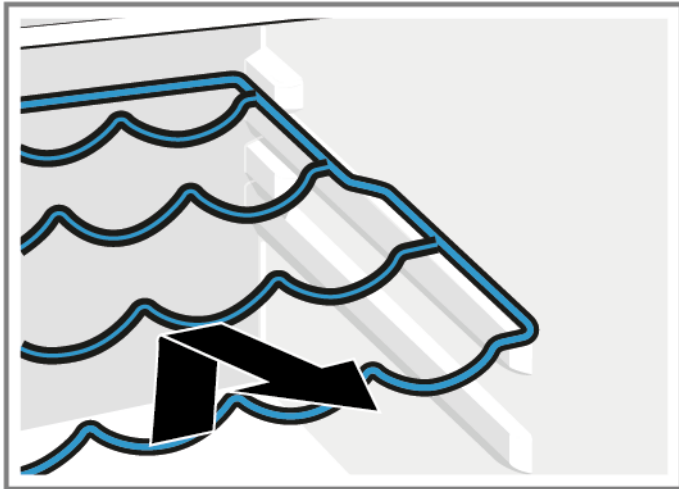

- ➡ Odkladací priestor na fľaše je odobratý.

4.8.2 Montáž odkladacieho priestoru na fľaše

- ▶ Pri montáži postupujte v opačnom poradí krokov demontáže.

4.9 Výmena poličky v dvierkach

Požiadavka:

- ✔ Dvierka sú otvorené.

4.9.1 Odobratie poličky v dvierkach

- ▶ Poličku v dvierkach zodvihnite smerom nahor.

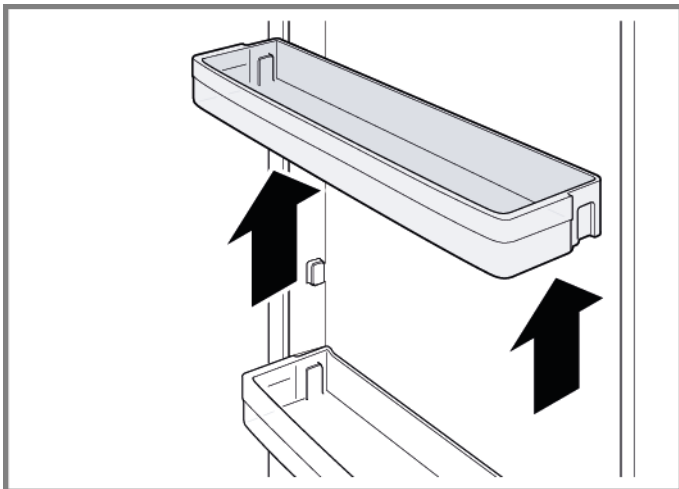

- ➡ Polička v dvierkach je odobratá.

4.9.2 Montáž poličky do dvierok

- ▶ Pri montáži postupujte v opačnom poradí krokov demontáže.

4.10 Výmena úložnej nádoby

Požiadavka:

- ✔ Dvierka sú otvorené.

4.10.1 Odobratie úložnej nádoby

1. Čo najviac vytiahnite úložnú nádobu.
2. 1. Nadvihnite úložnú nádobu za prednú časť (1).
2. Odoberte nádobu (2).

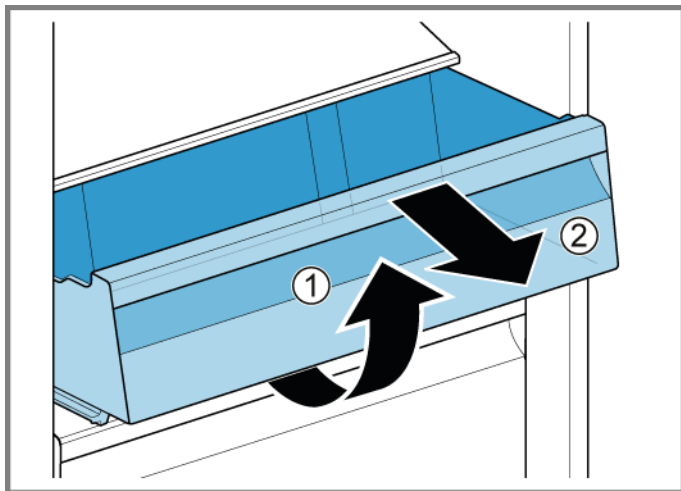

- ⚠ Úložná nádoba je odobratá.

4.10.2 Montáž úložnej nádoby

- ▶ Pri montáži postupujte v opačnom poradí krokov demontáže.

4.11 Výmena nádoby na ovocie a zeleninu

Požiadavka:

- ✔ Dvierka sú otvorené.

4.11.1 Odobratie nádoby na ovocie a zeleninu

1. Čo najviac vyťahnite nádobu na ovocie a zeleninu.
2. 1. Nadvihnite nádobu na ovocie a zeleninu za prednú časť (1).
2. Odoberte nádobu (2).

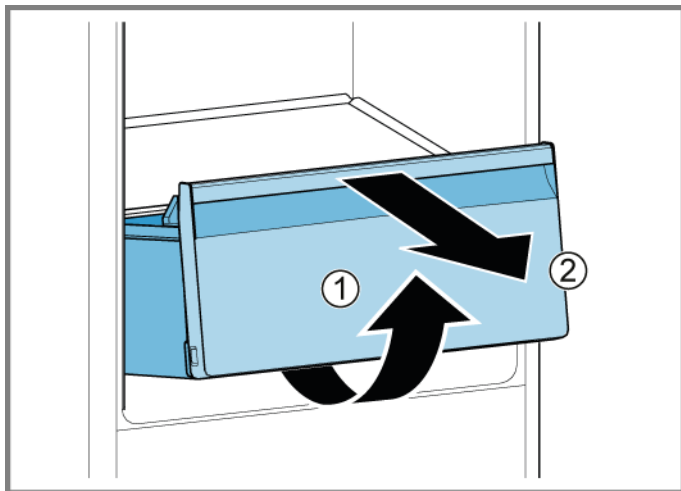

- ➡ Nádobu na ovocie a zeleninu je odobratá.

4.11.2 Montáž nádoby na ovocie a zeleninu

- ▶ Pri montáži postupujte v opačnom poradí krokov demontáže.

4.12 Výmena odkladacej plochy nad nádobou na ovocie a zeleninu

Požiadavka:

- ✔ Dvierka sú otvorené.
- ✔ [Nádoba na ovocie a zeleninu je odobratá.→587](#)

4.12.1 Odobratie odkladacej plochy nad nádobou na ovocie a zeleninu

1. Zatlačte tesniaci rám hore a von.

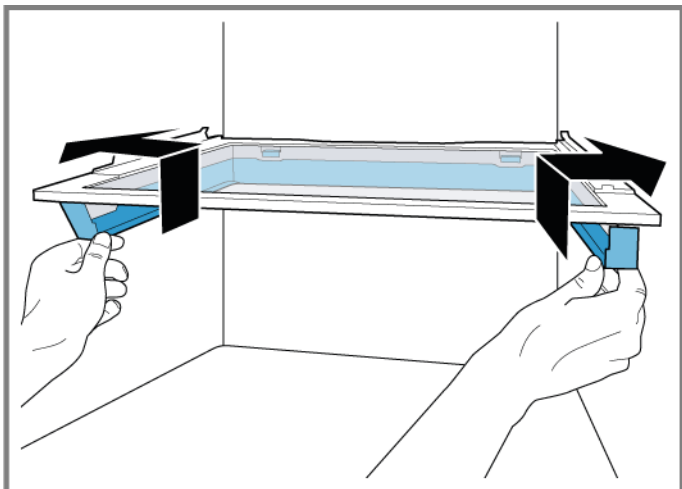

➡ Bočné háčiky sú uvoľnené.

2. Nadvihnite tesniaci rám a posuňte ho smerom dozadu.

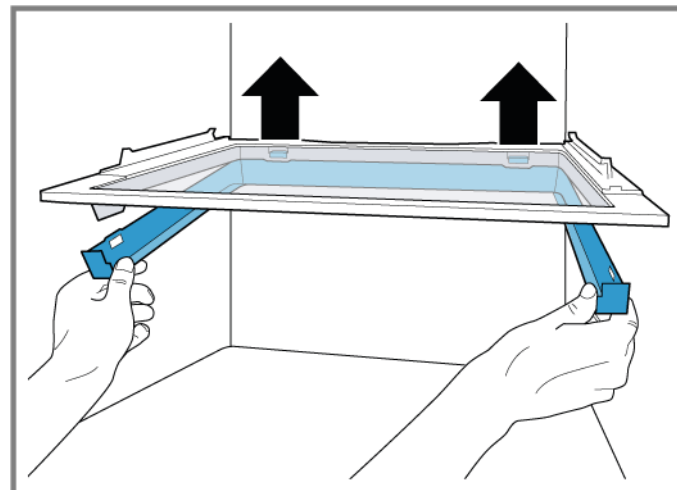

➡ Zadné háčiky sú uvoľnené.

3. Odoberte tesniaci rám.
4. Nadvihnite odkladaciu plochu nad nádobou na ovocie a zeleninu a vyklopte ju na bok.

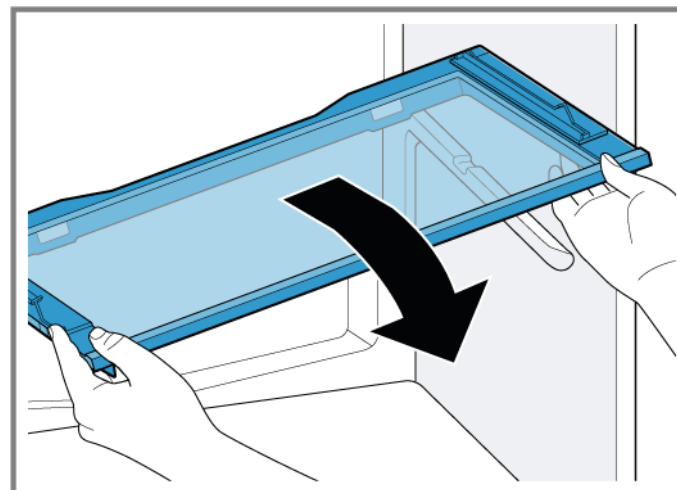

➡ Odkladacia plocha nad nádobou na ovocie a zeleninu je odobratá.

4.12.2 Montáž odkladacej plochy nad nádobu na ovocie a zeleninu

- ▶ Pri montáži postupujte v opačnom poradí krokov demontáže.

4.13 Výmena nádoby na zmrazené potraviny

Požiadavka:

- ✔ Dvierka sú otvorené.

4.13.1 Odobratie nádoby na zmrazené potraviny

- ▶ 1. Úplne vytiahnite nádobu na zmrazené potraviny (1).
- ▶ 2. Odoberte nádobu na varené potraviny (2).

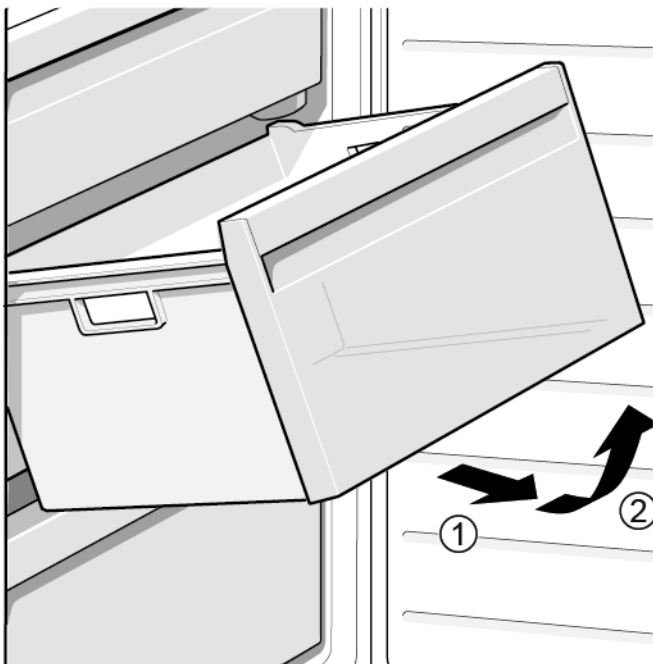

- ➡ Nádobu na zmrazené potraviny je odobratá.

4.13.2 Montáž nádoby na zmrazené potraviny

- ▶ Pri montáži postupujte v opačnom poradí krokov demontáže.

4.14 Výmena hornej LED žiarovky

Špeciálne nástroje:

 Špeciálny nástroj [00342180]

 Vo výbave vášho spotrebiča je bezúdržbové LED svetlo.
Tieto svetlá môže opravovať len zákaznícky servis alebo oprávnený technik!

 **NEBEZPEČENSTVO**
Nebezpečenstvo úrazu elektrickým prúdom pri dotyku s časťami pod napätím!
Ohrozenie života spôsobené elektrickým zásahom v prípade nesprávnej opravy

- ▶ Elektrické diely má opravovať kvalifikovaný elektrikár.
- ▶ Po oprave zariadenie vykonať bezpečnostný test v súlade s nariadením VDE 0701 alebo s miestnymi nariadeniami.



 **NEBEZPEČENSTVO**
Nebezpečenstvo úrazu elektrickým prúdom pri dotyku s časťami pod napätím!
Úmrtie v dôsledku zásahu elektrickým prúdom

- ▶ Odpojte spotrebiče od elektrického zdroja aspoň 60 sekúnd pred začiatkom opráv.

 **UPOZORNENIE**
Ostré hrany!
Rezné poranenia

- ▶ Noste ochranné rukavice.

Požiadavka:

-  Spotrebič je odpojený od elektrického napájania.
-  Dvierka sú otvorené.

4.14.1 Odobratie hornej LED žiarovky

1. Na uvoľnenie háčikov žiarovky (1) zasuňte nástroj na demontáž medzi hornú LED žiarovku a vnútornú priehradku v chladničke.
2. Odoberte hornú LED žiarovku (2).

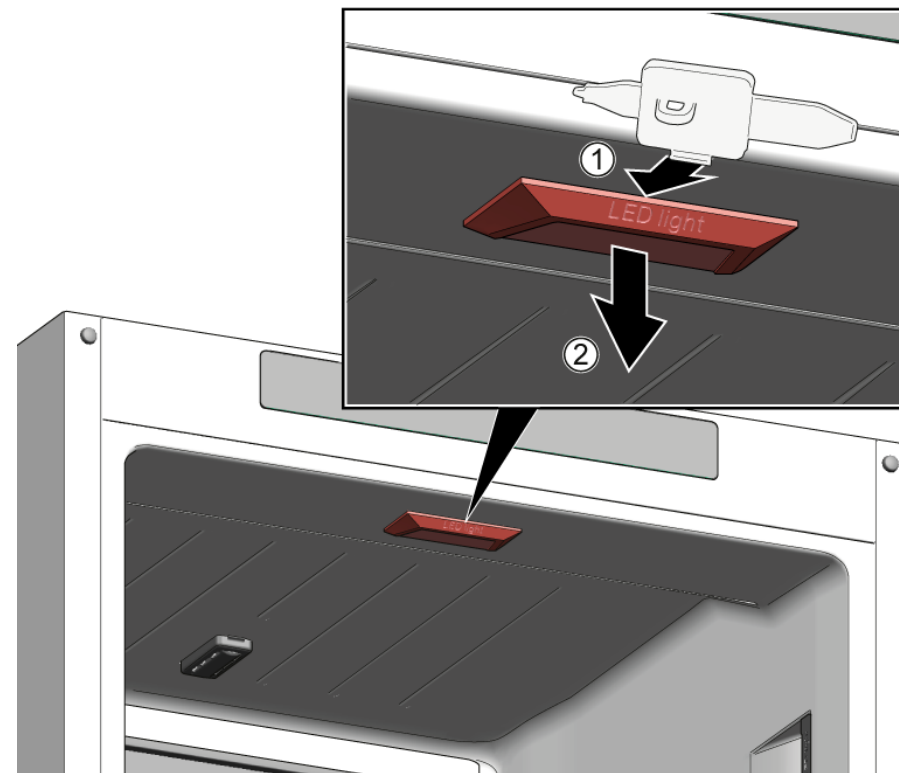

2. Odpojte elektrické pripojenie hornej LED žiarovky.
-  Horná LED žiarovka je odobratá.

4.14.2 Montáž hornej LED žiarovky

- ▶ Pri montáži postupujte v opačnom poradí krokov demontáže.

4.15 Výmena bočnej LED žiarovky

Špeciálne nástroje:

 Špeciálny nástroj [00342180]

	Vo výbave vášho spotrebiča je bezúdržbové LED svetlo. Tieto svetlá môže opravovať len zákaznícky servis alebo oprávnený technik!
---	---



	⚠ NEBEZPEČENSTVO
	Nebezpečenstvo úrazu elektrickým prúdom pri dotyku s časťami pod napätím! Ohrozenie života spôsobené elektrickým zásahom v prípade nesprávnej opravy <ul style="list-style-type: none"> ▶ Elektrické diely má opravovať kvalifikovaný elektrikár. ▶ Po oprave zariadenie vykonať bezpečnostný test v súlade s nariadením VDE 0701 alebo s miestnymi nariadeniami.

	⚠ NEBEZPEČENSTVO
	Nebezpečenstvo úrazu elektrickým prúdom pri dotyku s časťami pod napätím! Úmrtie v dôsledku zásahu elektrickým prúdom <ul style="list-style-type: none"> ▶ Odpojte spotrebiče od elektrického zdroja aspoň 60 sekúnd pred začiatkom opráv.

	⚠ UPOZORNENIE
	Ostré hrany! Rezné poranenia <ul style="list-style-type: none"> ▶ Noste ochranné rukavice.

	POZOR!
	Riziko poškodenia elektrostaticky citlivých komponentov (ESD)!! Poškodenie komponentov <ul style="list-style-type: none"> ▶ Pred dotknutím ESD použite systém elektrostatickej ochrany (náramok s uzemňovacou zástrčkou). ▶ Nedotýkajte sa prípojok a vedení vodičov modulov. ▶ ESD prepravujte iba vo vodivých materiáloch alebo v originálnom balení. ▶ ESD udržiavajte mimo materiálov, ktoré tvoria elektrostatický výboj (napr. plast).

Požiadavka:

-  Spotrebič je odpojený od elektrického napájania.
-  Dvierka sú otvorené.
-  RC tvarovky z interiéru sú odobraté.

4.15.1 Odobratie bočnej LED žiarovky

1. 1. Zasuňte nástroj na demontáž medzi difúzor žiarovky a plášť, čím uvoľníte háčik (1).
2. 2. Odsuňte difúzor žiarovky (2).
3. 3. Postupne rovnakým spôsobom uvoľníte upevňovacie háčiky difúzora.

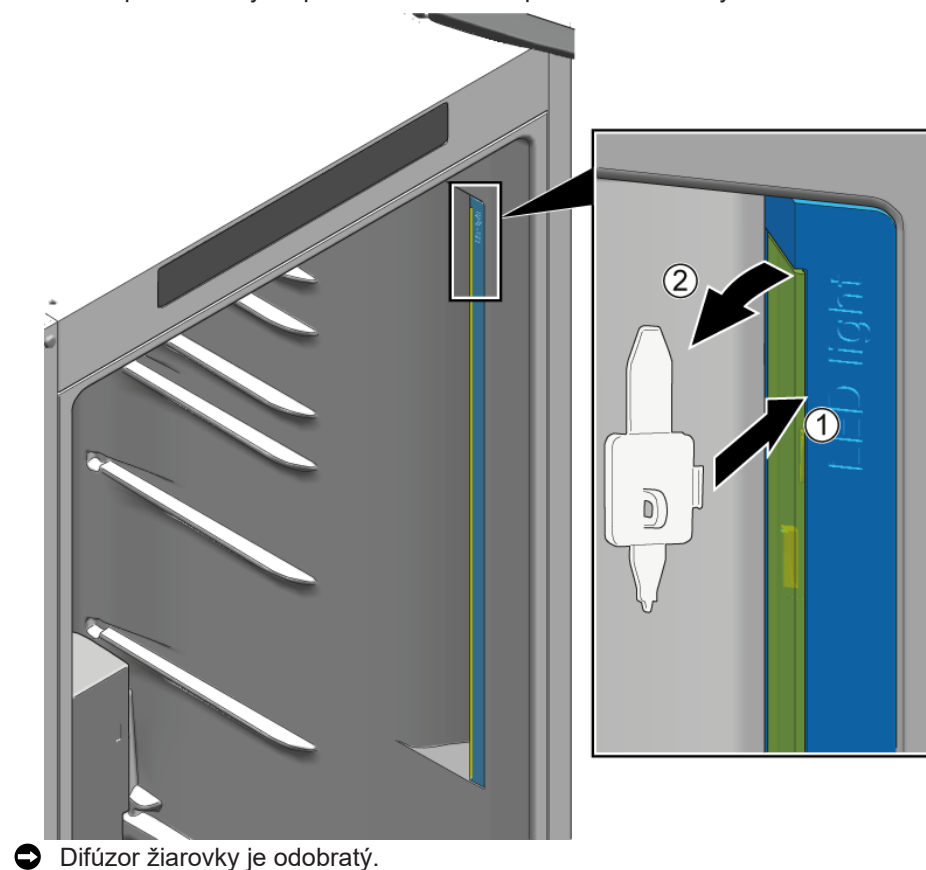

1. Stlačte upevňovací háčik a uvoľnite ho (1).
2. Na odobratie LED modulu a odpojenie z elektrickej zásuvky (2) ho posuňte nahor približne o 1 cm.
3. Odoberte LED modul (3).

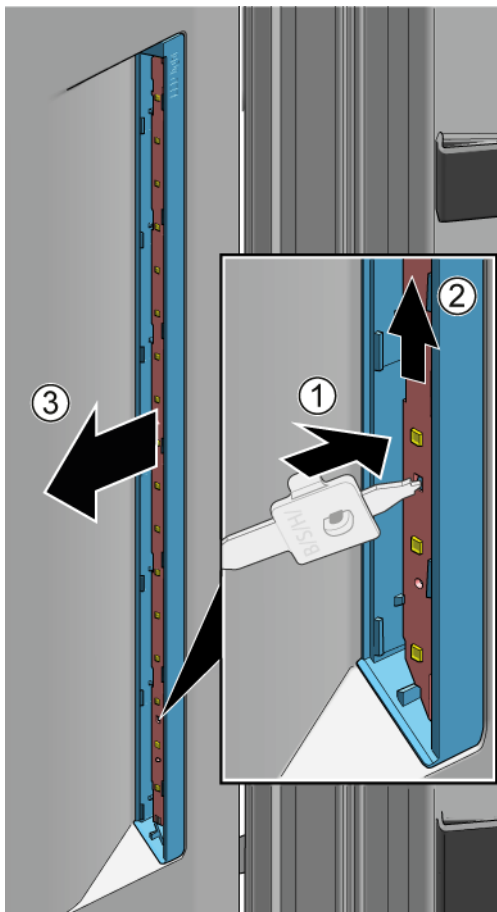

 Bočná LED žiarovka je odobratá.

4.15.2 Montáž bočnej LED žiarovky



Keďže háčiky difúzora žiarovky sú náchylné na zlomenie počas procesu odobrania, náhradný diel bočnej LED žiarovky je súprava, ktorá obsahuje LED modul a difúzor žiarovky.

1. Zasuňte nástroj na demontáž medzi difúzor žiarovky a plášť, čím uvoľníte háčik (1).
2. Odsuňte difúzor žiarovky (2).
3. Postupne rovnakým spôsobom uvoľnite upevňovacie háčiky difúzora.

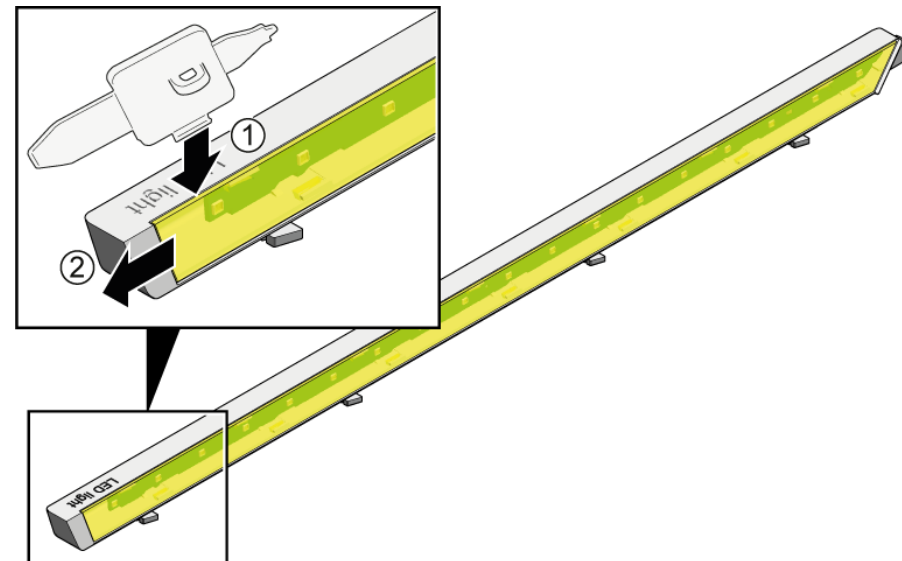

Oprava

1. Stlačte upevňovací háčik a uvoľnite ho (1).
2. Posuňte LED modul nahor smerom z krytu.
3. Kryt LED modulu, ktorý sa používa na prepravu náhradných dielov z bezpečnostných dôvodov zlikvidujte (3).

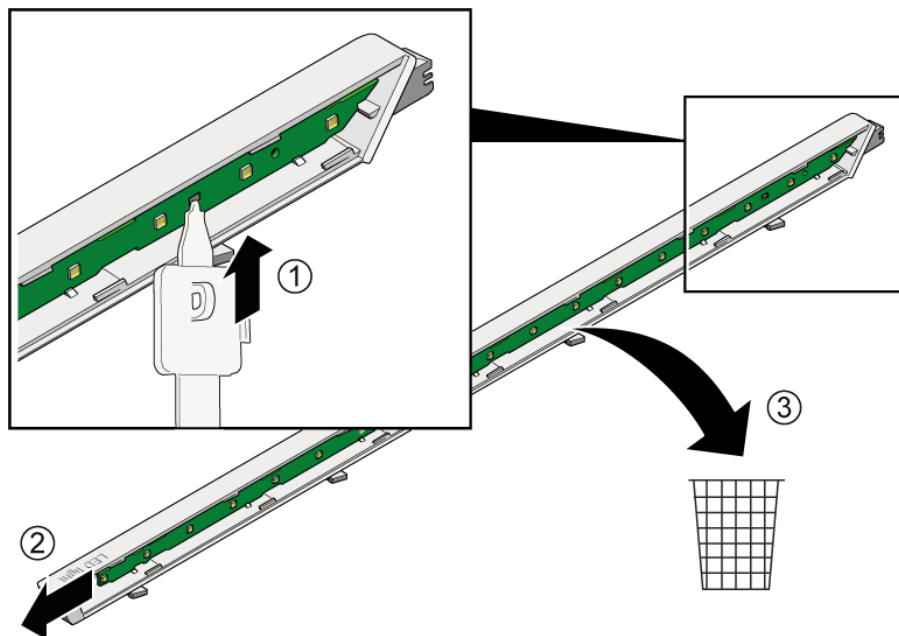



3. Pri odobratí LED modulu postupujte v opačnom poradí krokov montáže.

4.16 Výmena LED žiarovky v mrazničke

Špeciálne nástroje:

 Špeciálny nástroj [00342180]

 Vo výbave vášho spotrebiča je bezúdržbové LED svetlo. Tieto svetlá môže opravovať len zákaznícky servis alebo oprávnený technik!

 **NEBEZPEČENSTVO**
Nebezpečenstvo úrazu elektrickým prúdom pri dotyku s časťami pod napätím!
 Ohrozenie života spôsobené elektrickým zásahom v prípade nesprávnej opravy

- ▶ Elektrické diely má opravovať kvalifikovaný elektrikár.
- ▶ Po oprave zariadenie vykonať bezpečnostný test v súlade s nariadením VDE 0701 alebo s miestnymi nariadeniami.



 **NEBEZPEČENSTVO**
Nebezpečenstvo úrazu elektrickým prúdom pri dotyku s časťami pod napätím!
 Úmrtie v dôsledku zásahu elektrickým prúdom

- ▶ Odpojte spotrebiče od elektrického zdroja aspoň 60 sekúnd pred začiatkom opráv.

 **UPOZORNENIE**
Ostré hrany!
 Rezné poranenia

- ▶ Noste ochranné rukavice.



Požiadavka:

-  Spotrebič je odpojený od elektrického napájania.
-  Dvierka sú otvorené.

4.16.1 Odobratie LED žiarovky v mrazničke

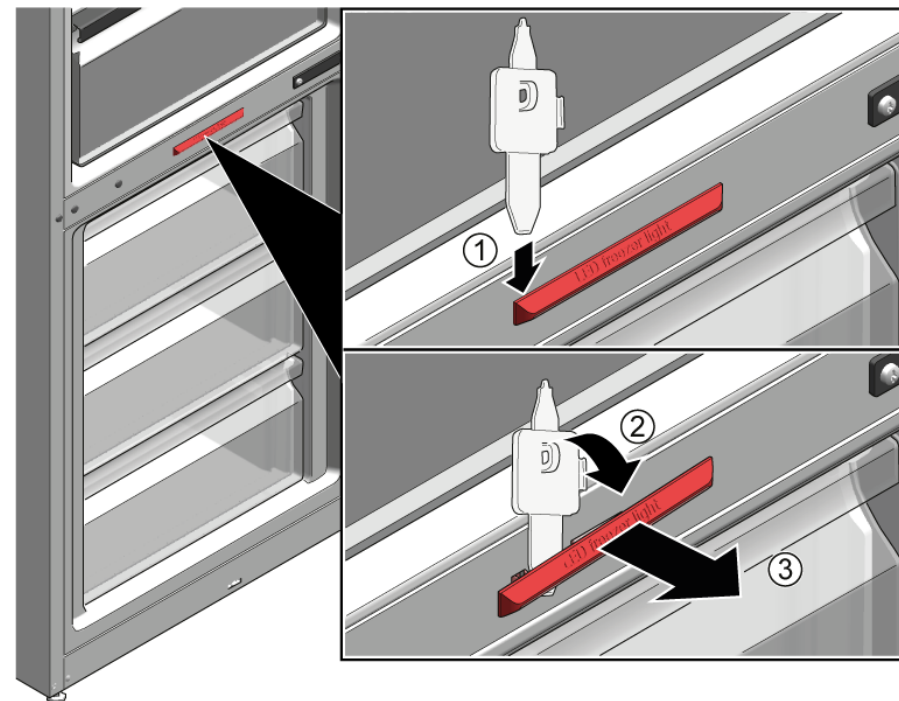
- ▶ 1. Na vytvorenie medzery zasunúť nástroj na demontáž medzi žiarovku a plášť na strane žiarovky (1).
- ▶ 2. Zasunúť nástroj na demontáž na druhej strane upevňovacieho háčika žiarovky a otočiť ho smerom dopredu (2).
- ▶ 3. Odobrať LED žiarovku v mrazničke (3).







-  LED žiarovka v mrazničke je odpojená.
-  LED žiarovka v mrazničke je odobratá.

4.16.2 Montáž LED žiarovky v mrazničke

- ▶ Pri montáži postupujte v opačnom poradí krokov demontáže.

Nasveti za popravilo - Hladilno-zamrzovalna kombinacija

 V zvezi s tem dokumentom	597		
1.1 Pomembne informacije	597		
1.1.1 Namen	597		
1.2 Razlaga simbolov	597		
1.2.1 Stopnje nevarnosti	597		
1.2.2 Simboli za nevarnost	597		
1.2.3 Struktura opozoril	598		
1.2.4 Splošni simboli	598		
 Varnost.....	599		
2.1 Splošna varnostna navodila	599		
2.1.1 Vsi gospodinjski aparati	599		
 Orodja in pripomočki.....	600		
 Popravilo	601		
4.1 Zamenjava tesnila vrat	601		
4.1.1 Odstranjevanje tesnila vrat	601		
4.1.2 Namestitev tesnila vrat	601		
4.2 Zamenjava ročaja vrat	604		
4.2.1 Odstranjevanje ročaja vrat	604		
4.2.2 Namestitev ročaja vrat	604		
4.3 Zamenjava zgornjega tečaja vrat	605		
4.3.1 Odstranjevanje zgornjega tečaja vrat	605		
4.3.2 Namestitev zgornjega tečaja vrat	606		
4.4 Zamenjava zgornjega tečaja vrat (vrata s prikazovalnikom).....	607		
4.4.1 Odstranjevanje zgornjega tečaja vrat	608		
4.4.2 Namestitev zgornjega tečaja vrat	609		
4.5 Zamenjava srednjega tečaja vrat	610		
4.5.1 Odstranjevanje srednjega tečaja vrat	610		
4.5.2 Namestitev srednjega tečaja vrat	611		
4.6 Zamenjava spodnjega tečaja vrat	612		
4.6.1 Odstranjevanje spodnjega tečaja vrat	612		
4.6.2 Namestitev spodnjega tečaja vrat	612		
4.7 Zamenjava police	613		
4.7.1 Odstranjevanje police	613		
4.7.2 Namestitev police	613		
4.8 Zamenjava nosilca za steklenice	614		
4.8.1 Odstranjevanje nosilca za steklenice	614		
4.8.2 Namestitev nosilca za steklenice	614		
4.9 Zamenjava vratnega predala	615		
4.9.1 Odstranjevanje vratnega predala	615		
4.9.2 Namestitev vratnega predala	615		
4.10 Zamenjava posode za shranjevanje	616		
4.10.1 Odstranjevanje posode za shranjevanje	616		
4.10.2 Namestitev posode za shranjevanje	616		
4.11 Zamenjava predala za sadje in zelenjavo	617		
4.11.1 Odstranjevanje predala za sadje in zelenjavo	617		
4.11.2 Namestitev predala za sadje in zelenjavo	617		
4.12 Zamenjava police nad predalom za sadje in zelenjavo	618		
4.12.1 Odstranjevanje police nad predalom za sadje in zelenjavo	618		
4.12.2 Namestitev police nad predalom za sadje in zelenjavo	619		
4.13 Zamenjava predala za zamrznjena živila	620		
4.13.1 Odstranjevanje predala za zamrznjena živila	620		
4.13.2 Namestitev predala za zamrznjena živila	620		
4.14 Zamenjava zgornje luči LED	621		
4.14.1 Odstranjevanje zgornje luči LED	621		
4.14.2 Namestitev zgornje luči LED	621		
4.15 Zamenjava stranske luči LED	622		
4.15.1 Odstranjevanje stranske luči LED	622		
4.15.2 Namestitev stranske luči LED	623		
4.16 Zamenjava luči LED v zamrzovalniku	625		
4.16.1 Odstranjevanje luči LED v zamrzovalniku	625		
4.16.2 Namestitev luči LED v zamrzovalniku	625		

i V zvezi s tem dokumentom

1.1 Pomembne informacije

1.1.1 Namen

Ti namigi za popravila uporabnika podpirajo pri lastnoročnem popravilu aparatov skladno z veljavno direktivo glede okoljsko primerne zasnove (od marca 2021).

Vsebujejo informacije o tem, kako zamenjati določene rezervne dele, vključno z opozorili in tveganji.

Če imate kakšna vprašanja, se obrnite na našo servisno službo. Za škodo bomo odgovorni le, če ste namige za popravila upoštevali pravilno.

1.2 Razlaga simbolov

1.2.1 Stopnje nevarnosti

Stopnje opozoril so sestavljene iz simbola in signalne besede. Signalna beseda označuje stopnjo nevarnosti.

Stopnja opozorila	Pomen
 NEVARNOST	Neupoštevanje opozorilnega sporočila bo povzročilo smrt ali hude poškodbe.
 OPOZORILO	Neupoštevanje opozorilnega sporočila lahko povzroči smrt ali hude poškodbe.
 PREVIDNO	Neupoštevanje opozorilnega sporočila lahko povzroči manjše poškodbe.
 POZOR!	Neupoštevanje opozorilnega sporočila lahko povzroči škodo na lastnini.

Preglednica 1: Stopnje nevarnosti



1.2.2 Simboli za nevarnost

Simboli za nevarnost so simbolni prikazi, ki podajajo informacije o vrsti nevarnosti.

V tem dokumentu so uporabljeni naslednji simboli za nevarnost:

Simbol za nevarnost	Pomen
	Splošno opozorilno sporočilo
	Nevarnost zaradi električne napetosti
	Nevarnost eksplozije
	Nevarnost ureznin
	Nevarnost zmečkanin

i V zvezi s tem dokumentom

Simbol za nevarnost	Pomen
	Nevarnost zaradi vročih površin
	Nevarnost zaradi močnega magnetnega polja
	Nevarnost zaradi neionizirajočega sevanja

Preglednica 2: Simboli za nevarnost

1.2.3 Struktura opozoril

Opozorila v tem dokumentu imajo standardiziran videz in standardizirano strukturo.



	<div style="background-color: red; color: white; padding: 2px; display: inline-block;">NEVARNOST</div> <p>Vrsta in vir nevarnosti! Morebitne posledice ob neupoštevanju nevarnosti/opozorila.</p> <ul style="list-style-type: none"> ▶ Ukrepi in prepovedi za preprečevanje nevarnosti.
--	--





V naslednjem primeru je prikazano opozorilo, ki opozarja pred električnim udarom zaradi delov pod napetostjo. Naveden je ukrep za preprečevanje nevarnosti.

	<div style="background-color: red; color: white; padding: 2px; display: inline-block;">NEVARNOST</div> <p>Nevarnost električnega udara zaradi delov pod napetostjo! Smrt zaradi električnega udara</p> <ul style="list-style-type: none"> ▶ Izključite aparate iz električnega omrežja vsaj 60 sekund pred začetkom popravil.
---	--

1.2.4 Splošni simboli

V tem dokumentu so uporabljeni naslednji splošni simboli:

Splošni simbol	Pomen
	Identifikacija posebnega nasveta (besedilo in/ali slika)
	Identifikacija preprostega nasveta (samo besedilo)
	Identifikacija povezave na video vadnico

Splošni simbol	Pomen
	Identifikacija potrebnih orodij
	Identifikacija potrebnih predpogojev
	Identifikacija pogoja (če ..., potem ...)
	Identifikacija rezultata
Začetek	Identifikacija tipke ali gumba
[00123456]	Identifikacija številke dela
Stanje	Identifikacija prikazanega besedila/okna (na zaslonu aparata)

Preglednica 3: Splošni simboli

2.1 Splošna varnostna navodila

2.1.1 Vsi gospodinjski aparati

Nevarnost električnega udara zaradi delov pod napetostjo!

- Napake zaradi popravil električnih komponent lahko povzročijo električni udar!
- Aparat izključite iz električnega omrežja vsaj 60 sekund pred začetkom del.
- Po popravilu je treba izvesti preizkus varnosti v skladu z VDE 0701 ali predpisi, ki veljajo za posamezno državo.

Nevarnost poškodb zaradi ostrih robov!

- Uporabljajte zaščitne rokavice.

Nevarnost zmečkanin med popravili, vzdrževanjem, odpravljanjem težav ali servisom zaradi težkih in premikajočih se komponent

- Uporabljajte zaščitne čevlje.
- Težke komponente zavarujte pred padanjem.
- Delov telesa ne vstavljajte v premikajoče se komponente.

Tveganje za varnost/delovanje aparata!

- Uporabljajte le originalne nadomestne dele.

Tveganje poškodb elektrostatično občutljivih komponent (ESD)!

- Ne dotikajte se modulov, vključno s povezavami in potmi vodnika.

Orodja in pripomočki

Oznaka	Podrobnosti	Slike
Nastavek Torx TX20 [00340865]	6,3 mm (1/4")	
Posebno orodje [00342180]		

4.1 Zamenjava tesnila vrat

Zahteva:

-  Vrata so odprta.

4.1.1 Odstranjevanje tesnila vrat

1. V levem in desnem kotu sprostite tesnilo vrat iz utora.



2. Tesnilo vrat izvlecite iz utora.



-  Tesnilo vrat je odstranjeno.

4.1.2 Namestitvev tesnila vrat



Debelina novega tesnila vrat se lahko nekoliko razlikuje od starega tesnila vrat. To ne vpliva na zapiranje in dolgoročno delovanje aparata.

Če ima aparat nastavljive tečaje ali priključke tečajev, lahko zapiranje naknadno tudi prilagodite.

Majhne stranske luknje v tesnilu vrat imajo svoj namen (potrebne so za prezračevanje). Ne gre za proizvodne napake.

Popravilo

1. Preverite, ali je utor za tesnilo poškodovan.

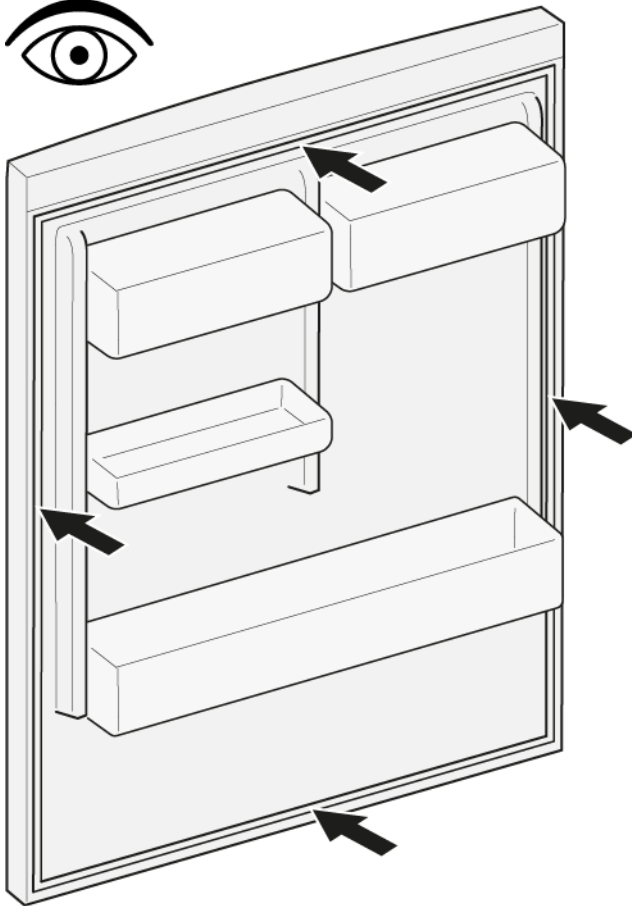

4. Vogale tesnila zgoraj in spodaj potisnite v utor.

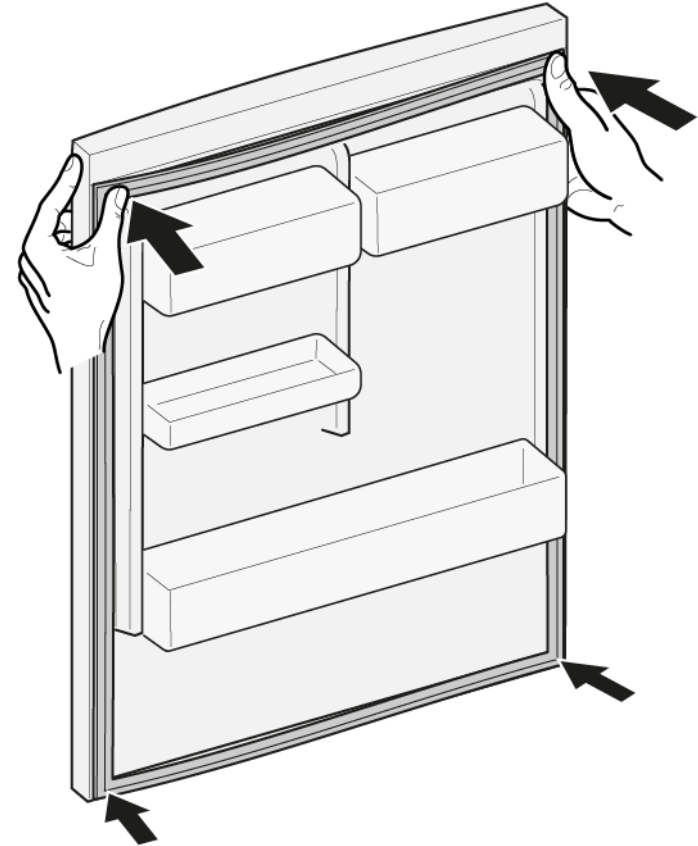

2.  Če je utor za tesnilo poškodovan:
 - se obrnite na našo servisno službo.

3.  Majhna deformacija tesnila vrat je običajna in ne vpliva na njegovo delovanje. Priporočljivo je, da tesnilo vrat pred namestitvijo v aparat poravnate.

Tesnilo vrat lahko segrejete s sušilnikom za lase ali toplo vodo, da ga ročno preoblikujete.

Popravilo



5. Celotno tesnilo korak po koraku potisnite v utor.





 Tesnilo vrat je nameščeno.

4.2 Zamenjava ročaja vrat

Posebna orodja:

-  Nastavek Torx TX20 6,3 mm (1/4") [00340865]
-  Ploščati izvijač Steblo 10 mm x 1,6 mm x 200 mm

Zahteva:

-  Aparat je odklopljen iz omrežne napetosti.
-  Vrata so odprta.

4.2.1 Odstranjevanje ročaja vrat

- ▶ 1. Odstranite dva pokrovčka vijakov (1).
- ▶ 2. Odvijte vijaka (2).
- ▶ 3. Odstranite ročaj vrat (3).

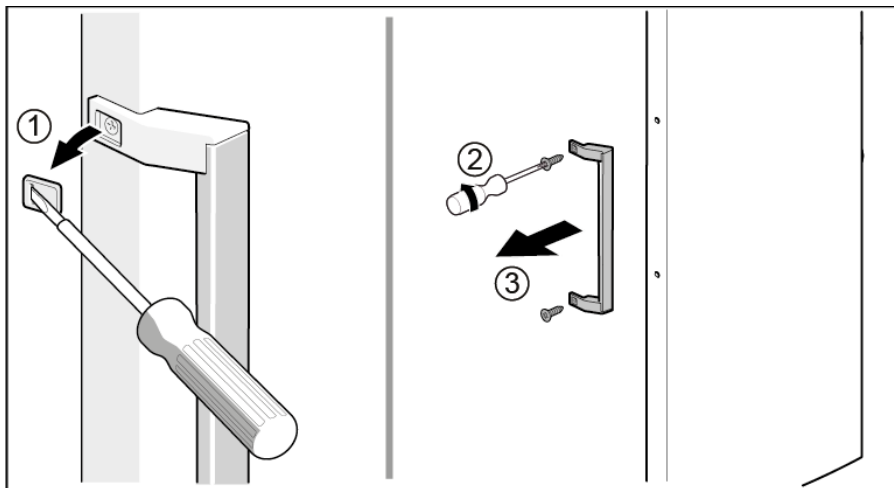

 Ročaj vrat je odstranjen.



Ročaj vrat za druga vrata lahko odstranite na enak način.

4.2.2 Namestitev ročaja vrat

- ▶ Namestite v obratnem vrstnem redu.

4.3 Zamenjava zgornjega tečaja vrat

Posebna orodja:

🔧 Nastavek Torx TX20 6,3 mm (1/4") [00340865]

	⚠️ OPOZORILO
Težki, veliki aparati!	
Poškodbe hrbta in mišic	
<ul style="list-style-type: none"> ▶ Postopek odstranjevanja vrat aparata naj izvaja samo pooblašče-no strokovno osebje. ▶ Za premikanje aparata sta potrebni dve osebi. ▶ Uporabite samo ustrezno orodje in opremo. 	

	⚠️ PREVIDNO
Ostri robovi!	
Ureznine	
<ul style="list-style-type: none"> ▶ Uporablajte zaščitne rokavice. 	

	⚠️ OPOZORILO
Zdrs nagnjenih aparatov!	
Zlomi kosti/zmečkanine	
<ul style="list-style-type: none"> ▶ Aparate zaščitite pred zdrsavanjem. 	

	⚠️ PREVIDNO
Nevarnost padajočih delov zaradi zrahljanih vijakov!	
Poškodbe zaradi padajočih delov.	
<ul style="list-style-type: none"> ▶ Komponento zaščitite pred padcem. 	

	POZOR!
Nevarnost padajočih delov zaradi zrahljanih vijakov!	
Škoda na drugih delih aparata ali pri uporabniku doma, npr. na tleh.	
<ul style="list-style-type: none"> ▶ Komponento zaščitite pred padcem. 	

Zahteva:

- ✔️ Aparat je odklopljen iz omrežne napetosti.
- ✔️ Notranji elementi aparata so odstranjeni.

4.3.1 Odstranjevanje zgornjega tečaja vrat

1. Pod podnožje potisnite podporni del.

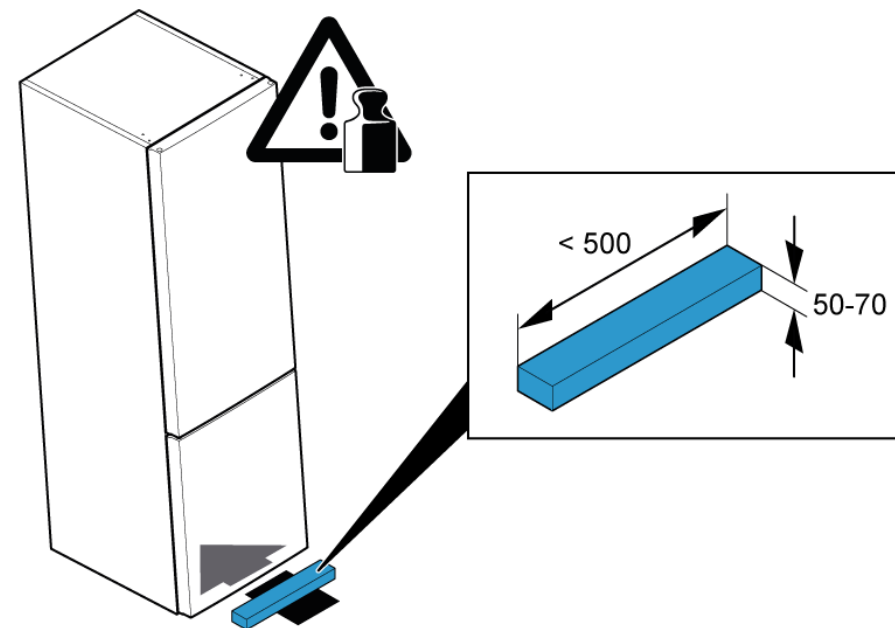

2.
 1. Odstranite pokrovček zgornjega tečaja (1).
 2. Odvijte vijaka (2).
 3. Odstranite zgornji tečaj (3).

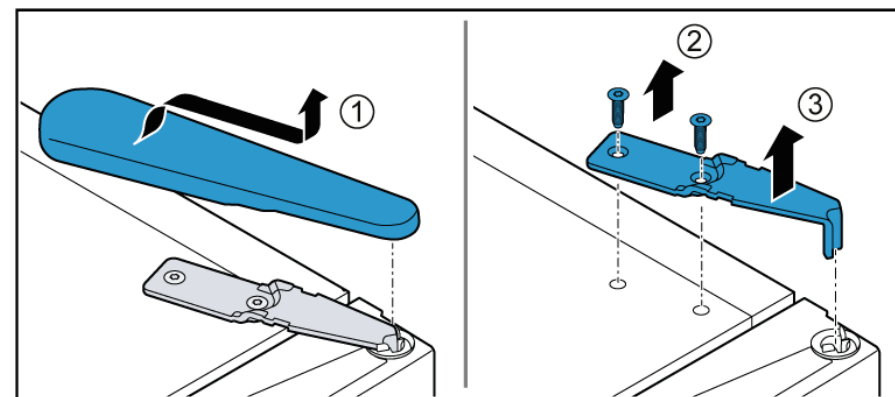

3. Odstranite zgornja vrata.

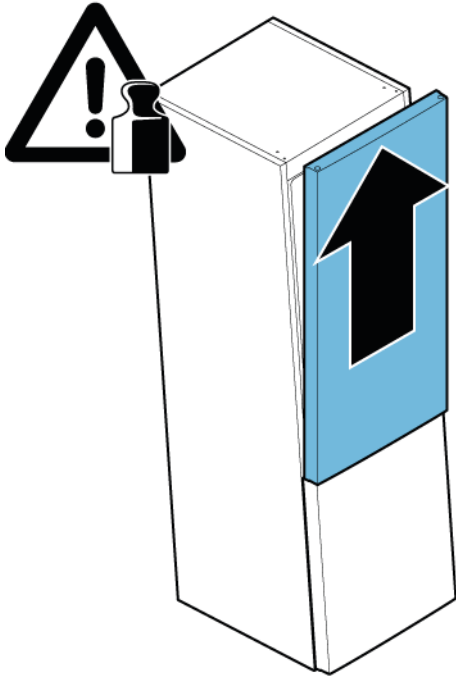

 Zgornji tečaj je odstranjen.



4.3.2 Namestitev zgornjega tečaja vrat



- ▶ Namestite v obratnem vrstnem redu.



4.4 Zamenjava zgornjega tečaja vrat (vrata s prikazovalnikom)



Posebna orodja:

 Nastavek Torx TX20 6,3 mm (1/4") [00340865]

	 OPOZORILO
	<p>Težki, veliki aparati! Poškodbe hrbta in mišic</p> <ul style="list-style-type: none"> ▶ Postopek odstranjevanja vrat aparata naj izvaja samo pooblaščen strokovno osebje. ▶ Za premikanje aparata sta potrebni dve osebi. ▶ Uporabite samo ustrezno orodje in opremo.

	 PREVIDNO
	<p>Ostri robovi! Ureznine</p> <ul style="list-style-type: none"> ▶ Uporabljajte zaščitne rokavice.

	 OPOZORILO
	<p>Zdrs nagnjenih aparatov! Zlomi kosti/zmečkanine</p> <ul style="list-style-type: none"> ▶ Aparate zaščitite pred zdrsavanjem.



	 PREVIDNO
	<p>Nevarnost padajočih delov zaradi zrahljanih vijakov! Poškodbe zaradi padajočih delov.</p> <ul style="list-style-type: none"> ▶ Komponento zaščitite pred padcem.

	POZOR!
	<p>Nevarnost padajočih delov zaradi zrahljanih vijakov! Škoda na drugih delih aparata ali pri uporabniku doma, npr. na tleh.</p> <ul style="list-style-type: none"> ▶ Komponento zaščitite pred padcem.

	 NEVARNOST
	<p>Nevarnost električnega udara zaradi delov pod napetostjo! Življenjska nevarnost zaradi električnega udara v primeru nepravilnega popravila</p> <ul style="list-style-type: none"> ▶ Električne dele mora popraviti kvalificiran električar. ▶ Po popravilu je treba izvesti preizkus varnosti v skladu z VDE 0701 ali predpisi, ki veljajo za posamezno državo.

	 NEVARNOST
	<p>Nevarnost električnega udara zaradi delov pod napetostjo! Smrt zaradi električnega udara</p> <ul style="list-style-type: none"> ▶ Izključite aparate iz električnega omrežja vsaj 60 sekund pred začetkom popravil.

Zahteva:

-  Aparat je odklopljen iz omrežne napetosti.
-  Notranji elementi aparata so odstranjeni.

4.4.1 Odstranjevanje zgornjega tečaja vrat

1. Pod podnožje potisnite podporni del.

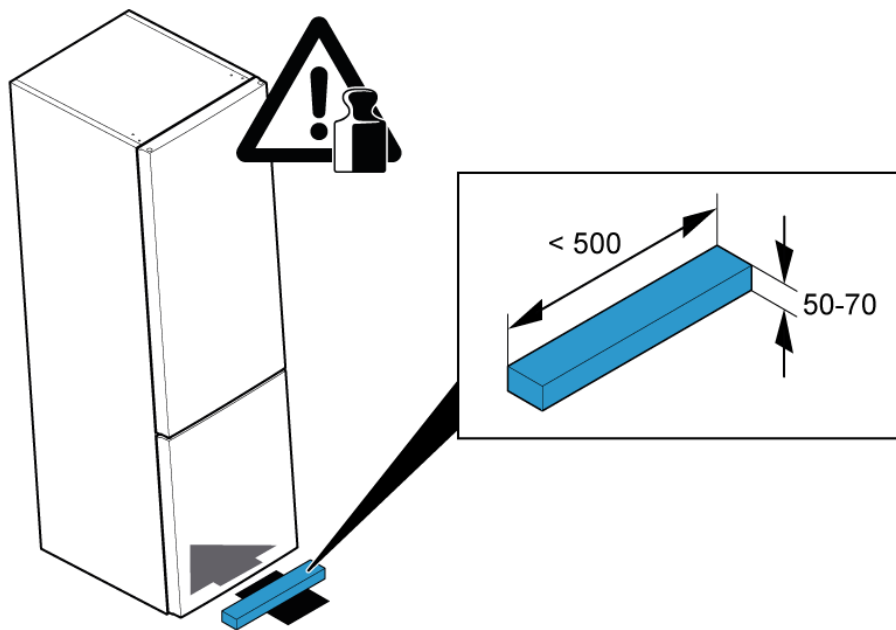

2. 1. Odstranite pokrovček zgornjega tečaja (1).
2. Odklopite električno povezavo (2).
3. Odvijte vijak za ozemljitev (3).

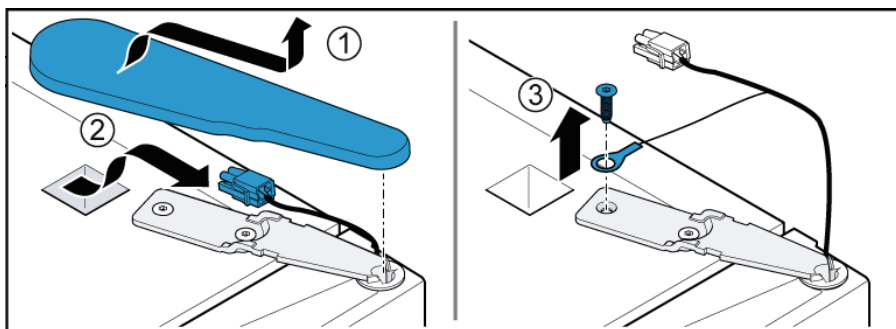

3. 1. Odvijte vijak (1).
2. Odstranite zgornji tečaj (2).

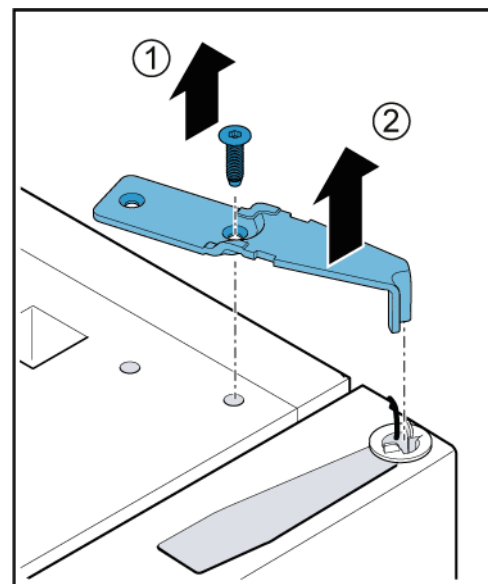

4. Odstranite zgornja vrata.

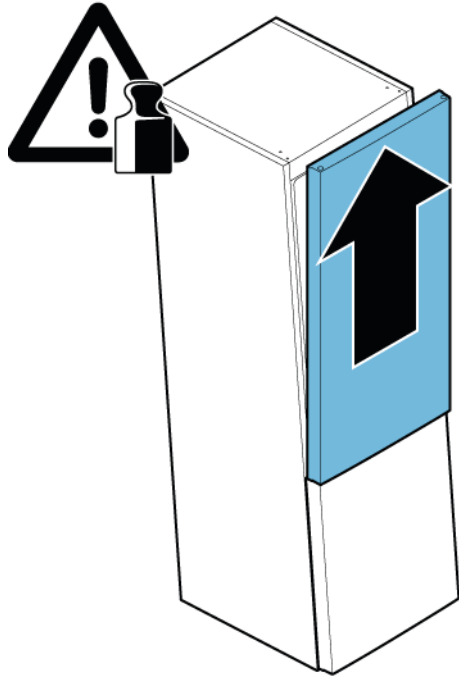

 Zgornji tečaj je odstranjen.

4.4.2 Namestitev zgornjega tečaja vrat

- ▶ Namestite v obratnem vrstnem redu.

4.5 Zamenjava srednjega tečaja vrat

Posebna orodja:

🌀 Nastavek Torx TX20 6,3 mm (1/4") [00340865]

	⚠️ OPOZORILO
	<p>Težki, veliki aparati! Poškodbe hrbta in mišic</p> <ul style="list-style-type: none"> ▶ Postopek odstranjevanja vrat aparata naj izvaja samo pooblašče-no strokovno osebje. ▶ Za premikanje aparata sta potrebni dve osebi. ▶ Uporabite samo ustrezno orodje in opremo.

	⚠️ PREVIDNO
	<p>Ostri robovi! Ureznine</p> <ul style="list-style-type: none"> ▶ Uporablajte zaščitne rokavice.

	⚠️ OPOZORILO
	<p>Zdrs nagnjenih aparatov! Zlomi kosti/zmečkanine</p> <ul style="list-style-type: none"> ▶ Aparate zaščitite pred zdrsavanjem.

	⚠️ PREVIDNO
	<p>Nevarnost padajočih delov zaradi zrahljanih vijakov! Poškodbe zaradi padajočih delov.</p> <ul style="list-style-type: none"> ▶ Komponento zaščitite pred padcem.

	POZOR!
	<p>Nevarnost padajočih delov zaradi zrahljanih vijakov! Škoda na drugih delih aparata ali pri uporabniku doma, npr. na tleh.</p> <ul style="list-style-type: none"> ▶ Komponento zaščitite pred padcem.

Zahteva:

- ✅ Aparat je odklopljen iz omrežne napetosti.
- ✅ Notranji elementi aparata so odstranjeni.
- ✅ Zgornji tečaj vrat je odstranjen.
- ✅ Zgornja vrata so odstranjena.

4.5.1 Odstranjevanje srednjega tečaja vrat

1. 1. Odvijte vijaka (1).
2. Odstranite srednji tečaj (2).

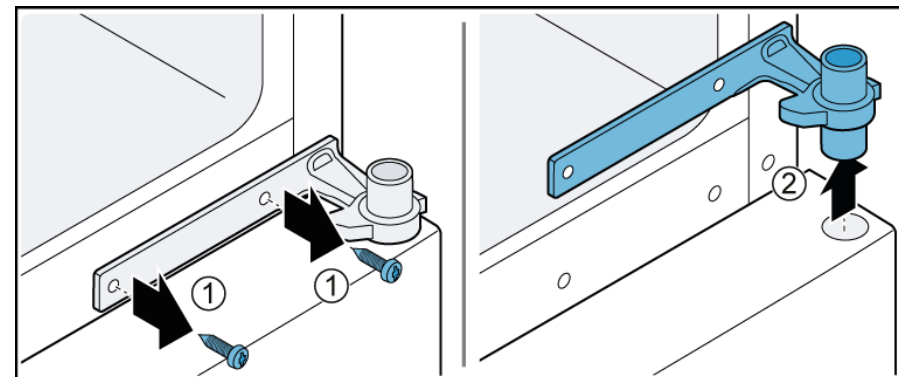

2. Odstranite spodnja vrata.

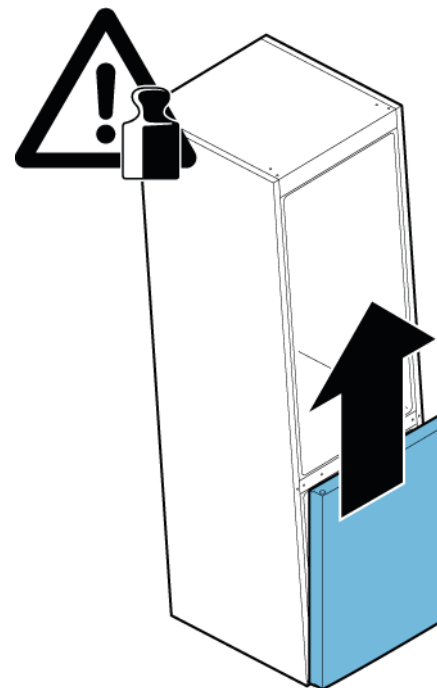

- ➡ Srednji tečaj je odstranjen.

4.5.2 Namestitev srednjega tečaja vrat

- ▶ Namestite v obratnem vrstnem redu.

4.6 Zamenjava spodnjega tečaja vrat

Posebna orodja:

🌀 Nastavek Torx TX20 6,3 mm (1/4") [00340865]

	⚠️ OPOZORILO
	<p>Težki, veliki aparati! Poškodbe hrbta in mišic</p> <ul style="list-style-type: none"> ▶ Postopek odstranjevanja vrat aparata naj izvaja samo pooblašče-no strokovno osebje. ▶ Za premikanje aparata sta potrebni dve osebi. ▶ Uporabite samo ustrezno orodje in opremo.

	⚠️ PREVIDNO
	<p>Ostri robovi! Ureznine</p> <ul style="list-style-type: none"> ▶ Uporabljajte zaščitne rokavice.

	⚠️ OPOZORILO
	<p>Zdrs nagnjenih aparatov! Zlomi kosti/zmečkanine</p> <ul style="list-style-type: none"> ▶ Aparate zaščitite pred zdrsavanjem.

	⚠️ PREVIDNO
	<p>Nevarnost padajočih delov zaradi zrahljanih vijakov! Poškodbe zaradi padajočih delov.</p> <ul style="list-style-type: none"> ▶ Komponento zaščitite pred padcem.

	POZOR!
	<p>Nevarnost padajočih delov zaradi zrahljanih vijakov! Škoda na drugih delih aparata ali pri uporabniku doma, npr. na tleh.</p> <ul style="list-style-type: none"> ▶ Komponento zaščitite pred padcem.

Zahteva:

- ✔️ Aparat je odklopljen iz omrežne napetosti.
- ✔️ Notranji elementi aparata so odstranjeni.
- ✔️ Zgornji tečaj je odstranjen.
- ✔️ Srednji tečaj je odstranjen.

4.6.1 Odstranjevanje spodnjega tečaja vrat

- ▶ 1. Odvijte vijaka (1).
- ▶ 2. Odstranite spodnji tečaj (2).

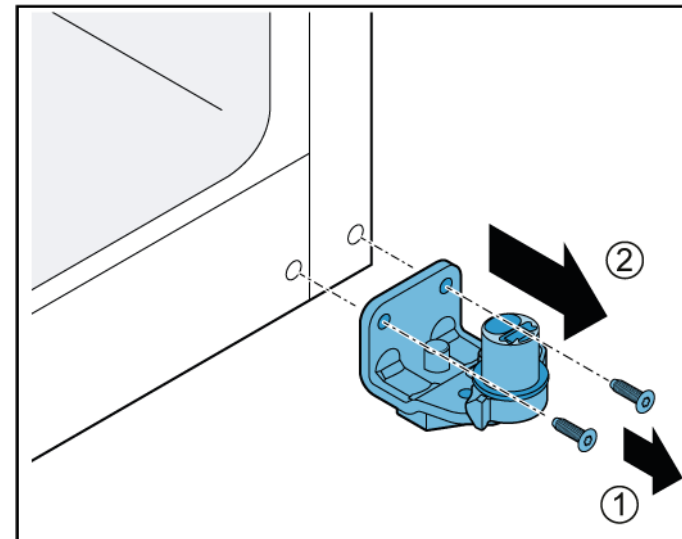

➡ Spodnji tečaj vrat je odstranjen.

4.6.2 Namestitev spodnjega tečaja vrat

- ▶ Namestite v obratnem vrstnem redu.

4.7 Zamenjava police

Zahteva:

- ✔ Vrata so odprta.

4.7.1 Odstranjevanje police

- ▶ 1. Dvignite polico zadaj (1).
- ▶ 2. Izpustite polico (2).

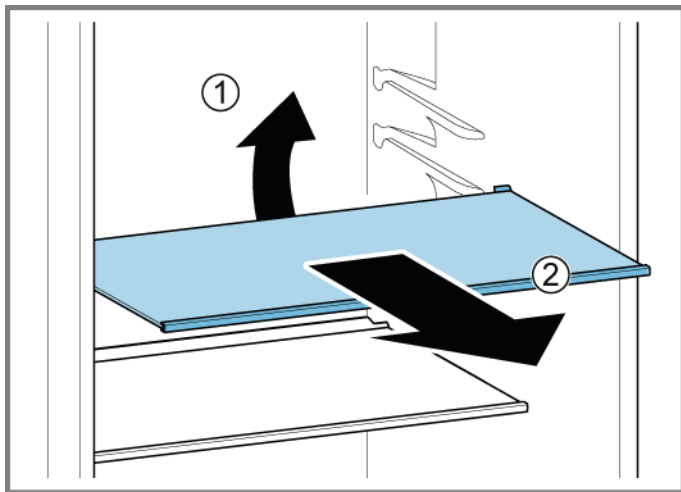

➡ Polica je odstranjena.

4.7.2 Namestitev police

- ▶ Namestite v obratnem vrstnem redu.

4.8 Zamenjava nosilca za steklenice

Zahteva:

- ✔ Vrata so odprta.

4.8.1 Odstranjevanje nosilca za steklenice

- ▶ Izvlecite nosilec za steklenice.

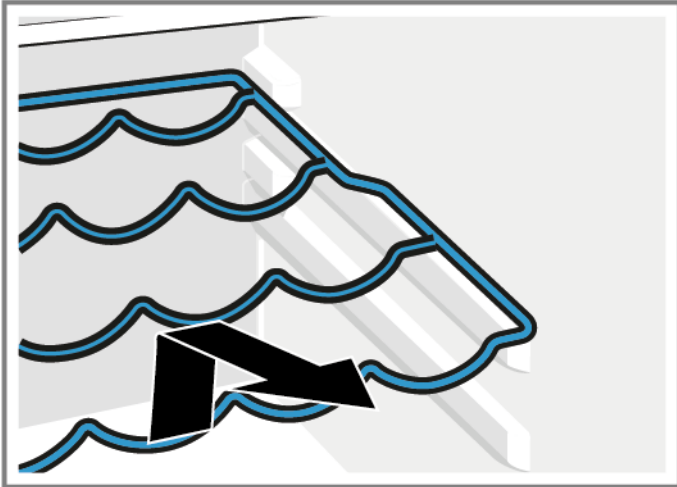

- ➡ Nosilec za steklenice je odstranjen.

4.8.2 Namestitev nosilca za steklenice

- ▶ Namestite v obratnem vrstnem redu.

4.9 Zamenjava vratnega predala

Zahteva:

- ✔ Vrata so odprta.

4.9.1 Odstranjevanje vratnega predala

- ▶ Dvignite vrtni predal navzgor.

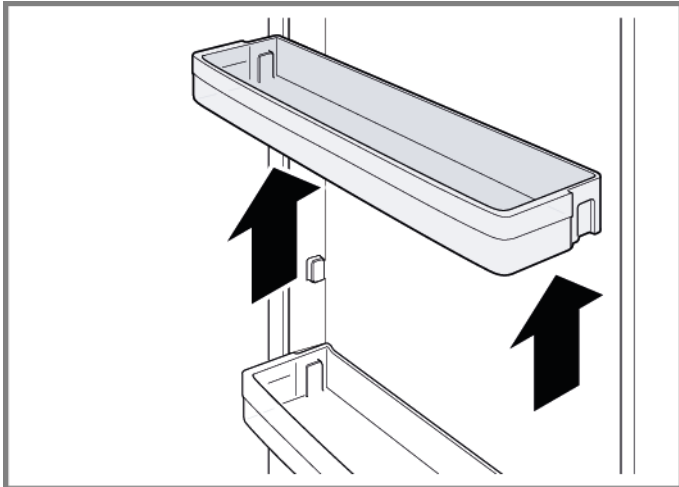

➡ Vratni predal je odstranjen.

4.9.2 Namestitev vratnega predala

- ▶ Namestite v obratnem vrstnem redu.

4.10 Zamenjava posode za shranjevanje

Zahteva:

- ✔ Vrata so odprta.

4.10.1 Odstranjevanje posode za shranjevanje

1. Posodo za shranjevanje izvlecite, kolikor je mogoče.
2. 1. Dvignite posodo za shranjevanje spredaj (1).
2. Predal odstranite (2).

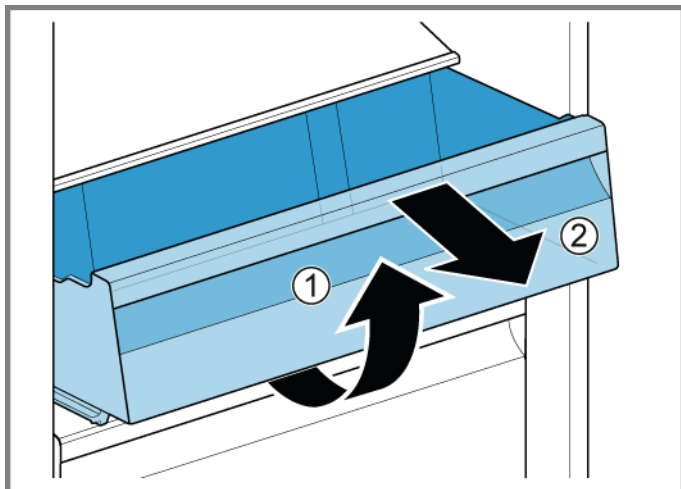

- ➔ Posoda za shranjevanje je odstranjena.

4.10.2 Namestitev posode za shranjevanje

- ▶ Namestite v obratnem vrstnem redu.

4.11 Zamenjava predala za sadje in zelenjavo

Zahteva:

- ✔ Vrata so odprta.

4.11.1 Odstranjevanje predala za sadje in zelenjavo

1. Predal za sadje in zelenjavo izvlecite, kolikor je mogoče.
2. 1. Dvignite predal za sadje in zelenjavo spredaj (1).
2. Predal odstranite (2).

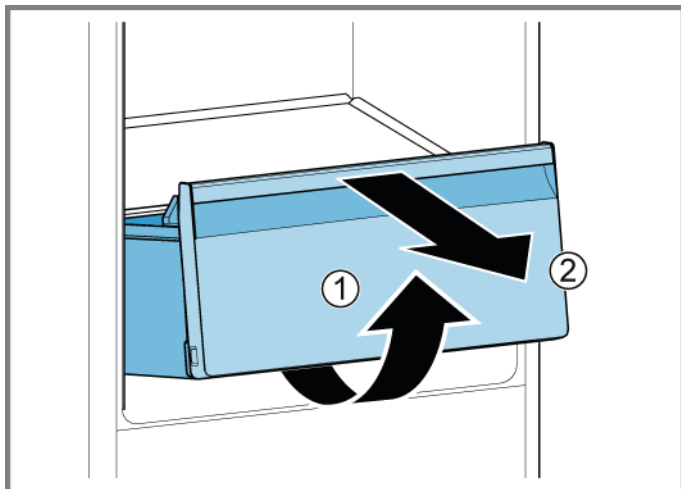

- ➔ Predal za sadje in zelenjavo je odstranjen.

4.11.2 Namestitev predala za sadje in zelenjavo

- ▶ Namestite v obratnem vrstnem redu.

4.12 Zamenjava police nad predalom za sadje in zelenjavo

Zahteva:

- ✔ Vrata so odprta.
- ✔ [Predal za sadje in zelenjavo je odstranjen. → 617](#)

4.12.1 Odstranjevanje police nad predalom za sadje in zelenjavo

1. Potisnite tesnilni okvir navzgor in navzven.

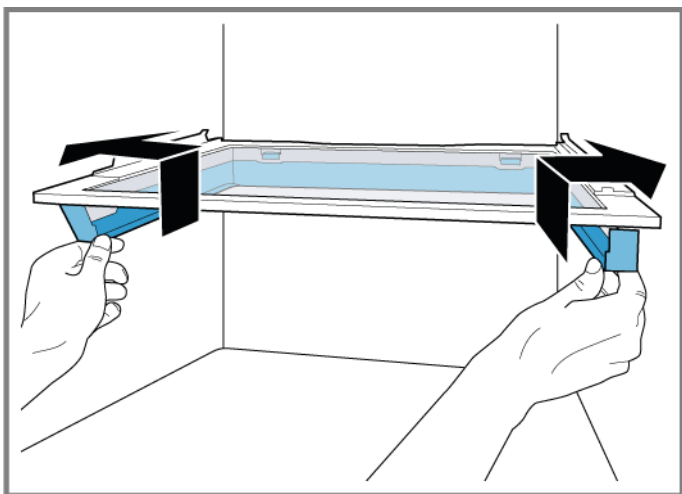

➡ Stranski zatiči se sprostijo.

2. Privzdignite tesnilni okvir in ga potisnite nazaj.

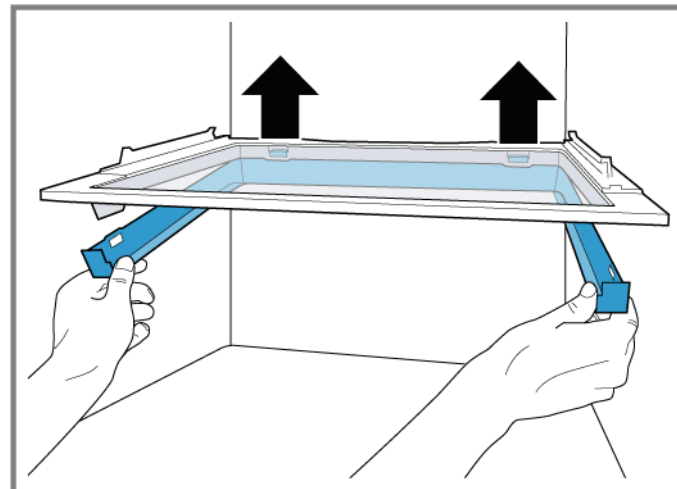

➡ Zadnji zatiči se sprostijo.

3. Odstranite tesnilni okvir.
4. Polico nad predalom za sadje in zelenjavo privzdignite in jo zanihajte na stran.

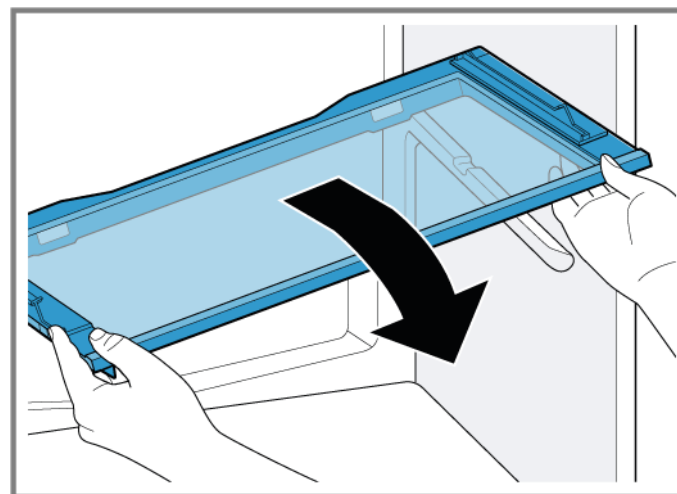

➡ Polica nad predalom za sadje in zelenjavo je odstranjena.

4.12.2 Namestitev police nad predalom za sadje in zelenjavo

- ▶ Namestite v obratnem vrstnem redu.

4.13 Zamenjava predala za zamrznjena živila

Zahteva:

- ✔ Vrata so odprta.

4.13.1 Odstranjevanje predala za zamrznjena živila

- ▶ 1. Predal za zamrznjena živila izvlecite do konca (1).
- ▶ 2. Odstranite predal za živila (2).

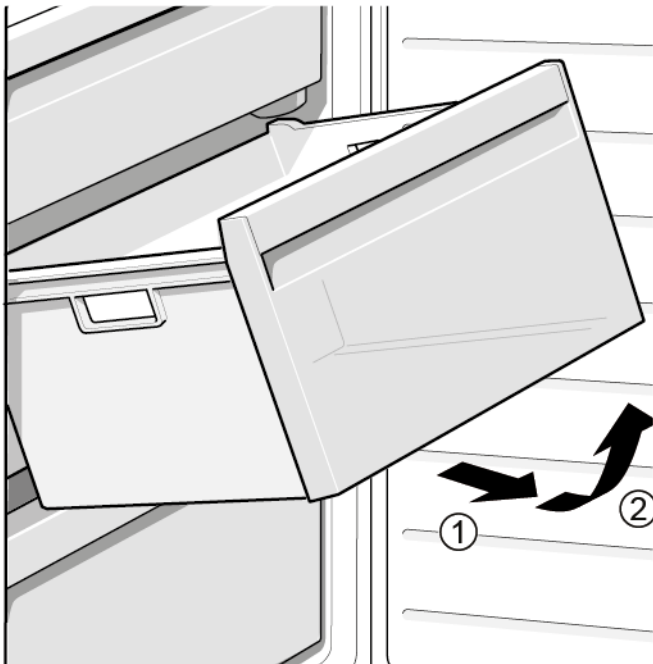

- ➡ Predal za zamrznjena živila je odstranjen.

4.13.2 Namestitev predala za zamrznjena živila

- ▶ Namestite v obratnem vrstnem redu.

4.14 Zamenjava zgornje luči LED

Posebna orodja:

🔧 Posebno orodje [00342180]



Vaš aparat je opremljen z osvetlitvijo LED, ki ne potrebuje vzdrževanja. To vrsto osvetlitve lahko popravi samo servisna služba ali pooblaščen strokovno osebje!



⚠️ NEVARNOST

Nevarnost električnega udara zaradi delov pod napetostjo!
Življenjska nevarnost zaradi električnega udara v primeru nepravilnega popravila

- ▶ Električne dele mora popraviti kvalificiran električar.
- ▶ Po popravilu je treba izvesti preizkus varnosti v skladu z VDE 0701 ali predpisi, ki veljajo za posamezno državo.



⚠️ NEVARNOST

Nevarnost električnega udara zaradi delov pod napetostjo!
Smrt zaradi električnega udara

- ▶ Izključite aparate iz električnega omrežja vsaj 60 sekund pred začetkom popravil.



⚠️ PREVIDNO

Ostri robovi!
Ureznine

- ▶ Uporabljajte zaščitne rokavice.

Zahteva:

- ✔ Aparat je odklopljen iz omrežne napetosti.
- ✔ Vrata so odprta.

4.14.1 Odstranjevanje zgornje luči LED

1. Orodje za demontažo potisnite med zgornjo luč LED in tesnilo hladilne komore tako, da sprostite zatiče luči (1).
2. Odstranite zgornjo luč LED (2).

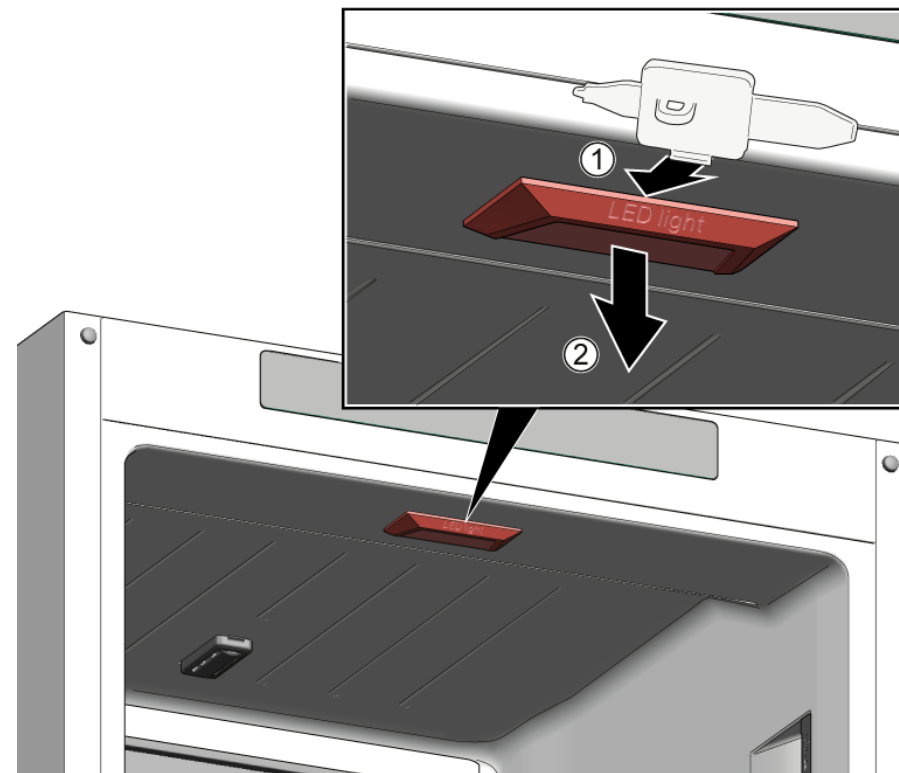

2. Odklopite električni priključek zgornje luči LED.
- ➡ Zgornja luč LED je odstranjena.

4.14.2 Namestitev zgornje luči LED

- ▶ Namestite v obratnem vrstnem redu.

4.15 Zamenjava stranske luči LED

Posebna orodja:

🔧 Posebno orodje

[00342180]



Vaš aparat je opremljen z osvetlitvijo LED, ki ne potrebuje vzdrževanja. To vrsto osvetlitve lahko popravi samo servisna služba ali pooblaščen strokovno osebje!



⚠️ NEVARNOST

Nevarnost električnega udara zaradi delov pod napetostjo!

Življenjska nevarnost zaradi električnega udara v primeru nepravilnega popravila

- ▶ Električne dele mora popraviti kvalificiran električar.
- ▶ Po popravilu je treba izvesti preizkus varnosti v skladu z VDE 0701 ali predpisi, ki veljajo za posamezno državo.



⚠️ NEVARNOST

Nevarnost električnega udara zaradi delov pod napetostjo!

Smrt zaradi električnega udara

- ▶ Izključite aparate iz električnega omrežja vsaj 60 sekund pred začetkom popravil.



⚠️ PREVIDNO

Ostri robovi!

Ureznine

- ▶ Uporabljajte zaščitne rokavice.



⚠️ POZOR!

Tveganje poškodb elektrostatično občutljivih komponent (ESD)!!

Poškodbe komponent

- ▶ Preden se dotaknete komponent ESD, uporabite sistem elektrostatične zaščite (zapestnico z ozemljitvenim priključkom).
- ▶ Ne dotikajte se povezav in poti vodnikov modulov.
- ▶ Komponente ESD transportirajte le v materialih, ki prevajajo tok, ali v originalni embalaži.
- ▶ Poskrbite, da komponente ESD ne bodo prišle v stik z materialom, ki se elektrostatično naelektri (npr. plastika).

Zahteva:

- ✓ Aparat je odklopljen iz omrežne napetosti.
- ✓ Vrata so odprta.
- ✓ Notranji elementi hladilne komore so odstranjeni.

4.15.1 Odstranjevanje stranske luči LED

1. Potisnite orodje za demontažo med pokrovček luči in ohišje, da sprostite kavelj (1).
2. Odstranite pokrovček luči (2).
3. Na isti način sprostite ostale pritrditvene kavlje.

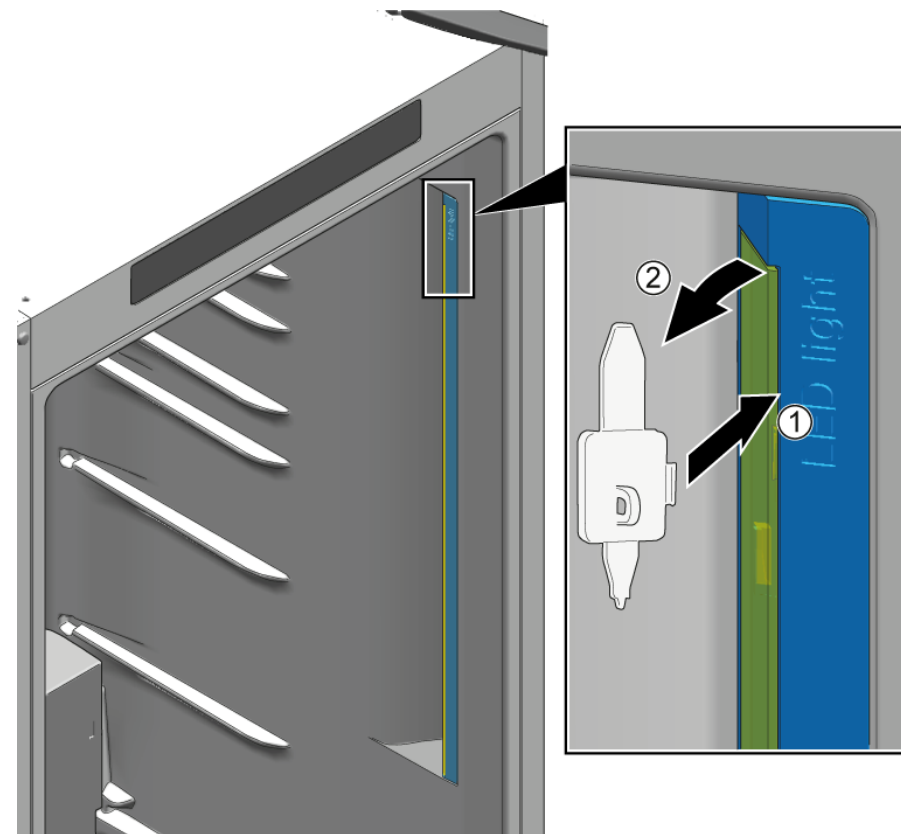

➡ Pokrovček luči je odstranjen.

Popravilo

1. Pritisnite pritrditveni kavelj, da ga sprostite (1).
2. Modul LED premaknite navzgor za pribl. 1 cm, da ga odstranite in odklopite iz električne vtičnice (2).
3. Odstranite modul LED (3).

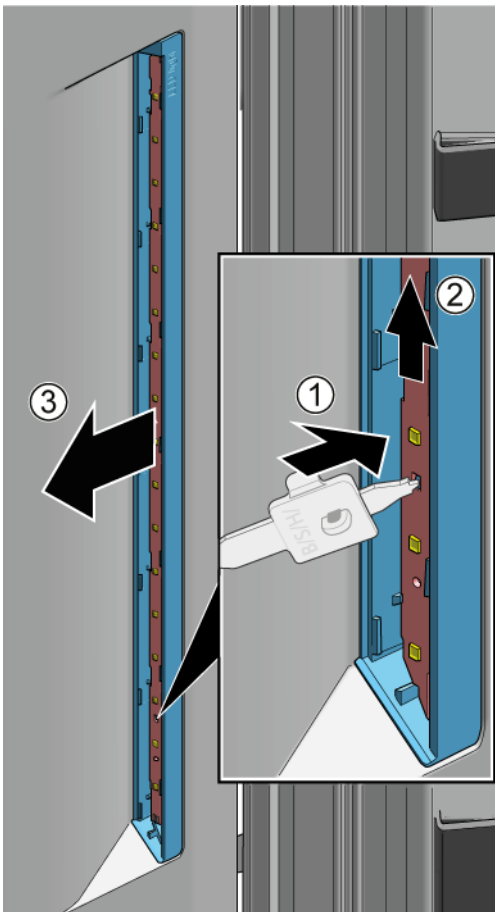

 Stranska luč LED je odstranjena.

4.15.2 Namestitev stranske luči LED



Ker se zatiči pokrovčka luči med postopkom odstranjevanja zlahka zlomijo, vključuje komplet stranske luči LED tako modul LED kot tudi pokrovček luči.

1. Potisnite orodje za demontažo med pokrovček luči in ohišje, da sprostite kavelj (1).
2. Odstranite pokrovček luči (2).
3. Na isti način sprostite ostale pritrditvene kavlje.

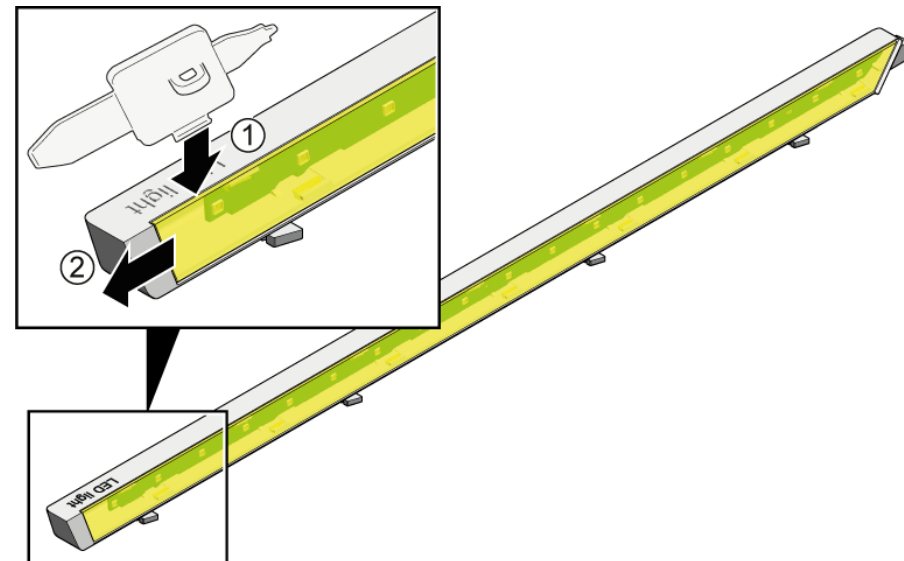

Popravilo

1. Pritisnite pritrditveni kavelj, da ga sprostite (1).
2. Potisnite modul LED navzgor, ven iz ohišja.
3. Ohišje modula LED, ki se varnostno uporabi za transport nadomestnega dela (3).

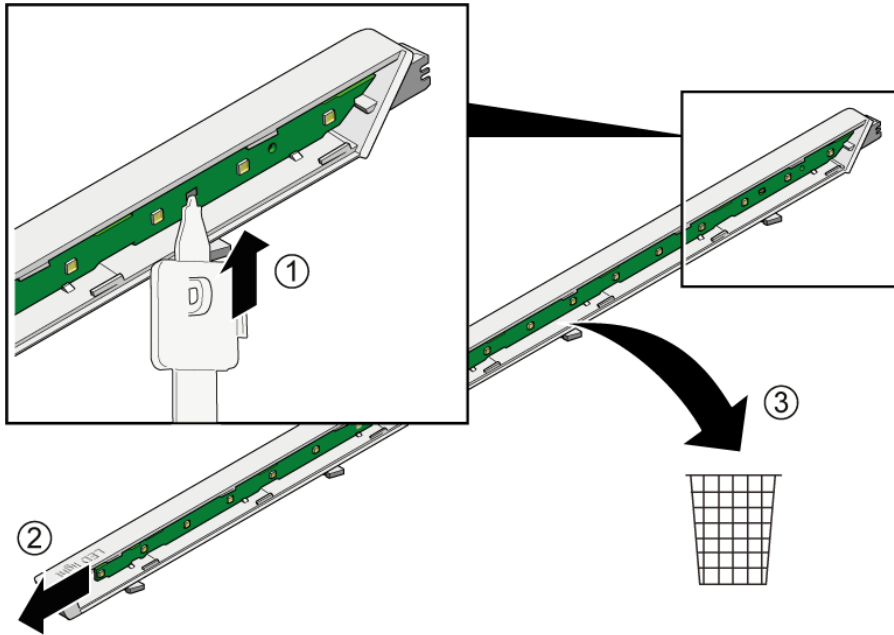

3. Vstavite modul LED in pokrovček luči v obratnem vrstnem redu kot pri demontaži.

4.16 Zamenjava luči LED v zamrzovalniku

Posebna orodja:

🔧 Posebno orodje [00342180]

i Vaš aparat je opremljen z osvetlitvijo LED, ki ne potrebuje vzdrževanja. To vrsto osvetlitve lahko popravi samo servisna služba ali pooblaščen strokovno osebje!

⚠️ NEVARNOST
Nevarnost električnega udara zaradi delov pod napetostjo!
 Življenjska nevarnost zaradi električnega udara v primeru nepravilnega popravila

- ▶ Električne dele mora popraviti kvalificiran električar.
- ▶ Po popravilu je treba izvesti preizkus varnosti v skladu z VDE 0701 ali predpisi, ki veljajo za posamezno državo.

⚠️ NEVARNOST
Nevarnost električnega udara zaradi delov pod napetostjo!
 Smrt zaradi električnega udara

- ▶ Izključite aparate iz električnega omrežja vsaj 60 sekund pred začetkom popravil.

⚠️ PREVIDNO
Ostri robovi!
 Ureznine

- ▶ Uporabljajte zaščitne rokavice.

Zahteva:

- ✔️ Aparat je odklopljen iz omrežne napetosti.
- ✔️ Vrata so odprta.

4.16.1 Odstranjevanje luči LED v zamrzovalniku

- ▶ 1. Potisnite orodje za demontažo med luč in ohišje na strani luči tako, da nastane reža (1).
- ▶ 2. Potisnite orodje za demontažo na drugi strani pritrditvenega zatiča luči in ga potisnite naprej (2).
- ▶ 3. Odstranite luč LED v zamrzovalniku (3).

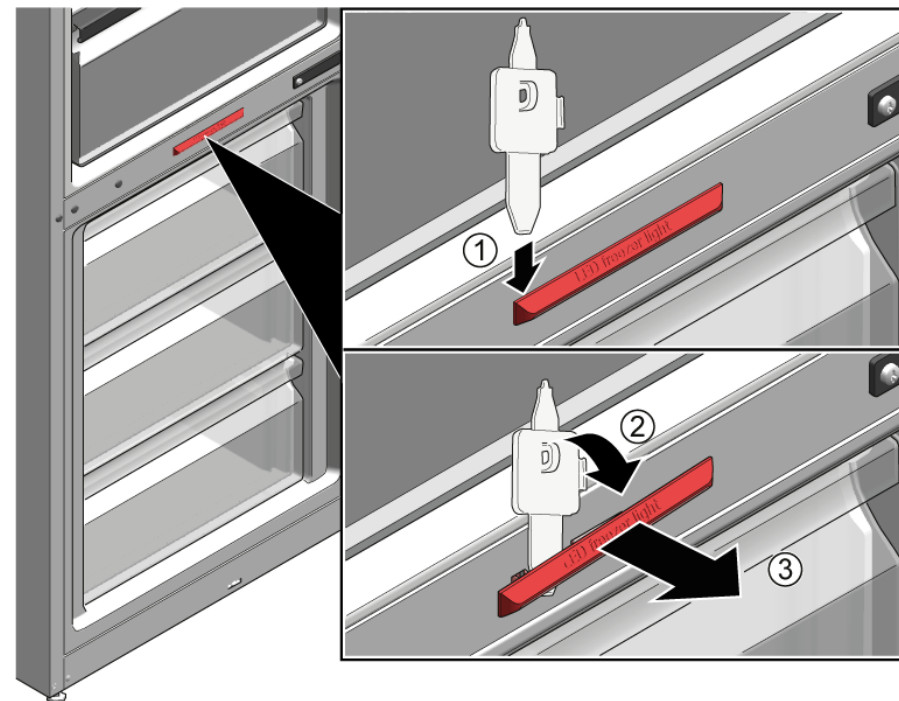





- ➡️ Luč LED v zamrzovalniku je odklopljena.
- ➡️ Luč LED v zamrzovalniku je odstranjena.

4.16.2 Namestitev luči LED v zamrzovalniku

- ▶ Namestite v obratnem vrstnem redu.

Consejos de reparación - Frigorífico / congelador

 En relación con este documento	627
1.1 Información importante	627
1.1.1 Finalidad	627
1.2 Explicación de símbolos generales	627
1.2.1 Niveles de peligrosidad	627
1.2.2 Símbolos de peligro	627
1.2.3 Estructura de las advertencias	628
1.2.4 Símbolos generales	628
 Seguridad	629
2.1 Instrucciones generales de seguridad	629
2.1.1 Todos los aparatos electrodomésticos.....	629
 Herramientas y auxiliares	630
 Reparación	631
4.1 Sustituir la junta de la puerta	631
4.1.1 Retirar la junta de la puerta.....	631
4.1.2 Montar la junta de la puerta	631
4.2 Sustituir el tirador de la puerta.....	634
4.2.1 Retirar el tirador de la puerta	634
4.2.2 Montar el tirador de la puerta	634
4.3 Sustituir la bisagra superior de la puerta	635
4.3.1 Desmontar la bisagra superior de la puerta.....	635
4.3.2 Montar la bisagra superior de la puerta	636
4.4 Sustituir la bisagra superior de la puerta (puerta con display).....	637
4.4.1 Desmontar la bisagra superior de la puerta.....	638
4.4.2 Montar la bisagra superior de la puerta	639
4.5 Sustituir la bisagra central de la puerta	640
4.5.1 Desmontar la bisagra central de la puerta.....	640
4.5.2 Montar la bisagra central de la puerta.....	641
4.6 Sustituir la bisagra inferior de la puerta	642
4.6.1 Desmontar la bisagra inferior de la puerta	642
4.6.2 Montar la bisagra inferior de la puerta	642
4.7 Sustituir el estante	643
4.7.1 Extraer el estante.....	643
4.7.2 Montar el estante	643
4.8 Sustituir la bandeja botellero.....	644
4.8.1 Extraer la bandeja botellero.....	644
4.8.2 Montar la bandeja botellero	644
4.9 Sustituir el estante de la puerta	645
4.9.1 Extraer el estante de la puerta.....	645
4.9.2 Montar el estante de la puerta	645
4.10 Sustituir el cajón de almacenamiento	646
4.10.1 Extraer el cajón de almacenamiento	646
4.10.2 Montar el cajón de almacenamiento	646
4.11 Sustituir el cajón para fruta y verdura	647
4.11.1 Extraer el cajón para fruta y verdura	647
4.11.2 Montar el cajón para fruta y verdura	647
4.12 Sustituir el estante que está encima del cajón para fruta y verdura	648
4.12.1 Retirar el estante que está encima del cajón para fruta y verdura	648
4.12.2 Montar el estante sobre el cajón para fruta y verdura.....	649
4.13 Sustituir el cajón de productos congelados	650
4.13.1 Extraer el cajón de productos congelados.....	650
4.13.2 Montar el cajón de productos congelados	650
4.14 Sustituir la lámpara LED superior	651
4.14.1 Desmontar lámpara LED superior.....	651
4.14.2 Montar la lámpara LED superior	651
4.15 Sustituir la lámpara LED lateral	652
4.15.1 Desmontar la lámpara LED lateral	652
4.15.2 Montar la lámpara LED lateral	653
4.16 Sustituir la lámpara LED del congelador	655
4.16.1 Desmontar la lámpara LED del congelador	655
4.16.2 Montar la lámpara LED del congelador	655

i En relación con este documento

1.1 Información importante

1.1.1 Finalidad

Estas indicaciones de reparación sirven como ayuda al consumidor para reparar aparatos por su cuenta conforme al reglamento aplicable sobre diseño ecológico (a partir de 03/2021).

Contienen información sobre cómo sustituir repuestos determinados e incluye las advertencias y los riesgos.

En caso de dudas, póngase en contacto con nuestro departamento de atención al cliente. Solo asumiremos la responsabilidad por daños si las indicaciones de reparación se han seguido correctamente.

1.2 Explicación de símbolos generales

1.2.1 Niveles de peligrosidad

Los niveles de peligro consisten en un símbolo y una palabra de advertencia. La palabra de advertencia identifica la gravedad del peligro.





Nivel de peligro	Significado
 PELIGRO	Si no se tiene en cuenta la advertencia, ocasionará la muerte o lesiones graves.
 ADVERTENCIA	Si no se tiene en cuenta la advertencia, puede ocasionar la muerte o lesiones graves.
 PRECAUCIÓN	Si no se tiene en cuenta la advertencia, puede ocasionar lesiones de carácter leve.
ATENCIÓN	Si no se tiene en cuenta la advertencia, puede ocasionar daños materiales.

Tabla 1: Niveles de peligrosidad

1.2.2 Símbolos de peligro

Los símbolos de peligro son una representación simbólica que indica el tipo de peligrosidad.

En este documento se utilizan los siguientes símbolos de peligro:

Símbolo de peligro	Significado
	Advertencia general
	Peligro de lesiones por corriente eléctrica
	Riesgo de explosión
	Peligro de lesiones a causa de cortes

En relación con este documento





Símbolo de peligro	Significado
	Peligro de lesiones por aplastamiento
	Peligro de lesiones por superficies calientes
	Peligro a causa de campos magnéticos de gran potencia
	Peligro derivado de radiación no ionizante

Tabla 2: Símbolos de peligro

1.2.3 Estructura de las advertencias

Las advertencias de este documento tienen una apariencia y una estructura uniformes.

	<div style="background-color: red; color: white; padding: 2px; text-align: center;"> PELIGRO</div> <p>¡Tipo y fuente del peligro! Posibles consecuencias de ignorar el peligro / la advertencia.</p> <ul style="list-style-type: none"> ▶ Medidas y prohibiciones para prevenir el peligro.
--	---

El ejemplo siguiente muestra una advertencia de descarga eléctrica a causa de piezas o partes cargadas con tensión. Se menciona la medida para evitar el peligro.

	<div style="background-color: red; color: white; padding: 2px; text-align: center;"> PELIGRO</div> <p>¡Riesgo de descarga eléctrica debido a partes con tensión! Muerte por electrocución</p> <ul style="list-style-type: none"> ▶ Desconectar el aparato de la red al menos 60 segundos antes de comenzar con la reparación.
--	---

1.2.4 Símbolos generales

En este documento se utilizan los siguientes símbolos generales:

Símbolo general	Significado
	Identificación de una indicación especial (texto y/o gráfico)







Símbolo general	Significado
	Identificación de un consejo simple (solo texto)
	Identificación de un enlace a un video tutorial
	Identificación de una herramienta requerida
	Identificación de una condición previa (prerrequisito)
	Identificación de una condición (si ..., entonces ...)
	Identificación de un resultado
Iniciar	Identificación de una tecla o botón
[00123456]	Identificación de un número de material
Estado	Identificación del texto / ventana mostrado (en el display del aparato)

Tabla 3: Símbolos generales

2.1 Instrucciones generales de seguridad

2.1.1 Todos los aparatos electrodomésticos

¡Riesgo de descarga eléctrica debido a piezas con tensión!

- ¡Los errores en las reparaciones que incluyan componentes eléctricos pueden provocar una descarga eléctrica!
- Desconectar el aparato de la red durante al menos 60 segundos antes de comenzar con el trabajo.
- Después de la reparación, encargar una prueba de seguridad conforme a VDE 0701 o los reglamentos específicos del país.

¡Riesgo de lesiones debido a bordes afilados!

- Usar guantes de protección.

Riesgo de aplastamiento durante la reparación, mantenimiento, resolución de problemas y servicio debido a componentes pesados y móviles

- Usar calzado de seguridad.
- Asegure los componentes pesados para que no se caigan.
- No pegue partes del cuerpo en componentes móviles.

¡Riesgo para la seguridad/el funcionamiento del aparato!

- Utilizar únicamente los repuestos originales.

¡Riesgo de daños de los componentes sensibles a cargas electrostáticas (ESD)!

- No tocar los módulos, incluidas las conexiones y las pistas conductoras.

Herramientas y auxiliares

Designacion	Detalles	Imagenes
Punta Torx TX20 [00340865]	6,3 mm (1/4")	
Herramienta espe- cial [00342180]		

4.1 Sustituir la junta de la puerta

Requisito:

- ✔ La puerta está abierta.

4.1.1 Retirar la junta de la puerta

1. Soltar la junta de la puerta de la ranura por las esquinas izquierda y derecha.



2. Sacar la junta de la puerta de la ranura.



- ➡ Se ha retirado la junta de la puerta.

4.1.2 Montar la junta de la puerta



El grosor de la nueva junta de la puerta puede diferir ligeramente del grosor de la junta usada. Esto no afectará al comportamiento de cierre ni al funcionamiento a largo plazo.

Si su aparato tienen bisagras ajustables o accesorios de bisagra, puede optimizar el comportamiento de cierre.

Los pequeños agujeros laterales de la junta de la puerta son funcionales (necesarios para la ventilación). No se trata de un fallo de producción.

Reparación

1. Comprobar si la ranura de la junta presenta daños.

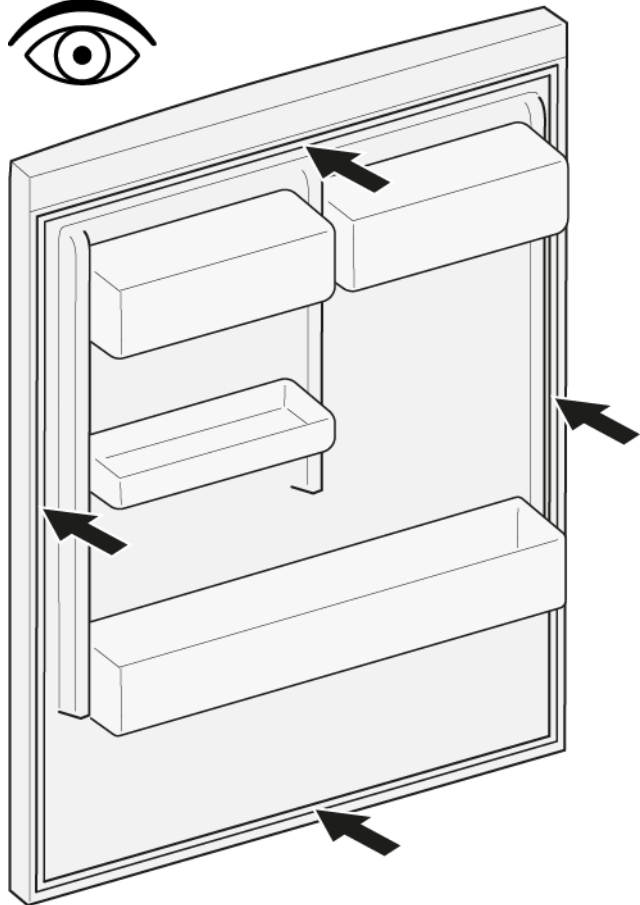

4. Presionar las esquinas de la junta en la parte superior y la inferior de la ranura.



2.  Si la ranura de la junta está dañada.
 - Contactar con el servicio de atención al cliente.

3.

	Una ligera deformación de la junta de la puerta es normal y no afecta a su función. Se recomienda alisar la junta de la puerta antes de insertarla en el aparato.
---	---

Calentar ligeramente la junta de la puerta con un secador de pelo o agua caliente y volver a darle forma con las manos.

Reparación



5. Presionar metiendo toda la junta paso a paso en la ranura.





-  La junta de la puerta está montada.

4.2 Sustituir el tirador de la puerta

Herramientas necesarias:

-  Punta Torx TX20 6,3 mm (1/4") [00340865]
-  Destornillador plano Punta 10 mm x 1,6 mm x 200 mm

Requisito:

-  El aparato está desconectado del suministro eléctrico.
-  La puerta está abierta.

4.2.1 Retirar el tirador de la puerta

- ▶ 1. Retirar las tapas de los dos tornillos (1).
- ▶ 2. Desatornillar los dos tornillos (2).
- ▶ 3. Retirar el tirador de la puerta (3).

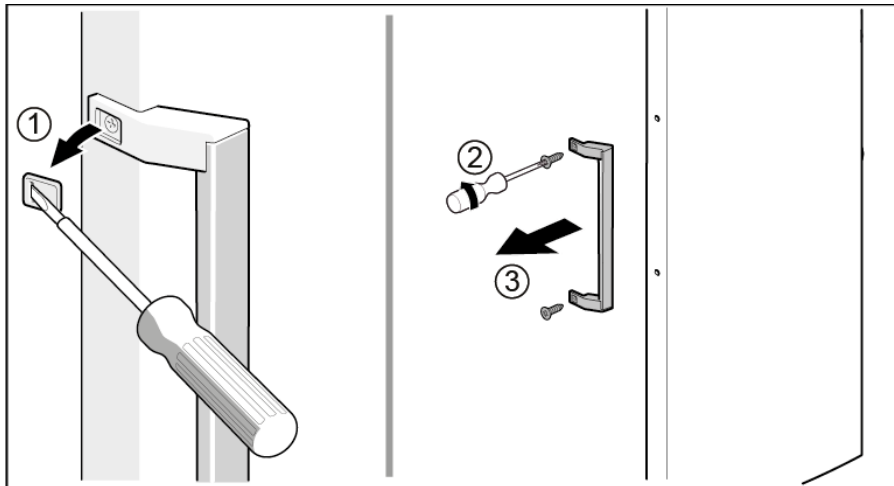

 Se ha retirado el tirador de la puerta.



El tirador de la segunda puerta puede retirarse del mismo modo.

4.2.2 Montar el tirador de la puerta

- ▶ Montar en orden inverso.

4.3 Sustituir la bisagra superior de la puerta

Herramientas necesarias:

🔧 Punta Torx TX20 6,3 mm (1/4") [00340865]

	⚠️ ADVERTENCIA
	<p>¡Aparatos pesados y voluminosos! Espalda y lesiones musculares</p> <ul style="list-style-type: none"> ▶ La operación de extraer la puerta del aparato solo deben llevarla a cabo especialistas formados. ▶ Para mover el aparato se necesitan dos personas. ▶ Utilizar únicamente herramientas y equipos apropiados.

	⚠️ PRECAUCIÓN
	<p>¡Bordes o cantos cortantes! Peligro de cortes</p> <ul style="list-style-type: none"> ▶ Usar guantes de seguridad.

	⚠️ ADVERTENCIA
	<p>¡Deslizamiento de aparatos inclinados! Fracturas óseas / lesiones por aplastamiento</p> <ul style="list-style-type: none"> ▶ Asegurar los electrodomésticos contra deslizamientos.

	⚠️ PRECAUCIÓN
	<p>¡Riesgo de que se caigan piezas debido a los tornillos aflojados! Peligro de lesiones debido a piezas que caigan.</p> <ul style="list-style-type: none"> ▶ Asegure el componente para que no se caiga.

	ATENCIÓN
	<p>¡Riesgo de que se caigan piezas debido a los tornillos aflojados! Daños en otras partes del aparato o en el domicilio del consumidor, p. ej., en la parte inferior.</p> <ul style="list-style-type: none"> ▶ Asegure el componente para que no se caiga.

Requisito:

- ✅ El aparato está desconectado del suministro eléctrico.
- ✅ Se han retirado los accesorios del interior del aparato.

4.3.1 Desmontar la bisagra superior de la puerta

1. Deslizar la pieza de soporte debajo de la sección base.

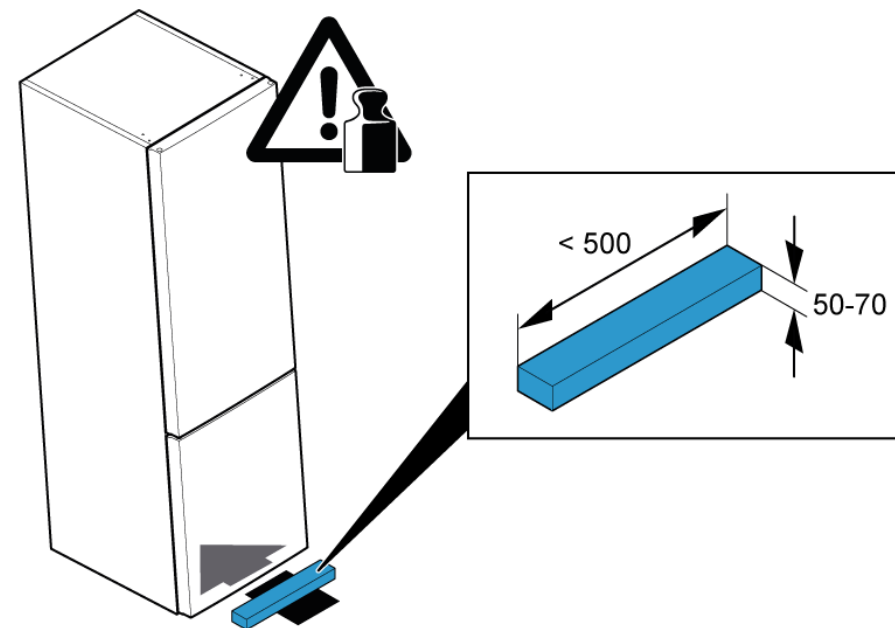

2. 1. Retirar la cubierta de la bisagra superior (1).
2. Desatornillar los dos tornillos (2).
3. Retirar la bisagra superior (3).

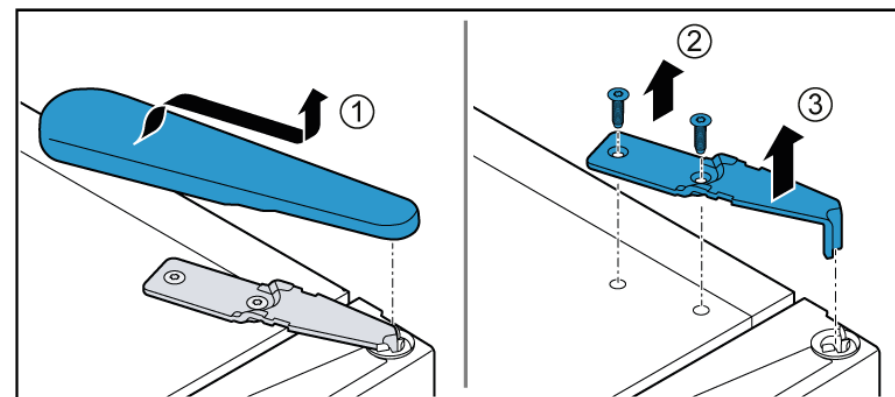

3. Retirar la puerta superior.

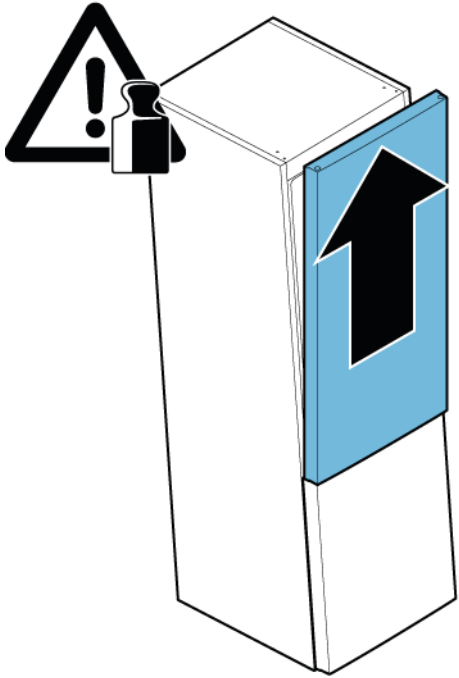

 Se ha retirado la bisagra superior.

4.3.2 Montar la bisagra superior de la puerta

▶ Montar en orden inverso.

4.4 Sustituir la bisagra superior de la puerta (puerta con display)

Herramientas necesarias:

 Punta Torx TX20 6,3 mm (1/4") [00340865]

	⚠ ADVERTENCIA
	<p>¡Aparatos pesados y voluminosos! Espalda y lesiones musculares</p> <ul style="list-style-type: none"> ▶ La operación de extraer la puerta del aparato solo deben llevarla a cabo especialistas formados. ▶ Para mover el aparato se necesitan dos personas. ▶ Utilizar únicamente herramientas y equipos apropiados.

	⚠ PRECAUCIÓN
	<p>¡Bordes o cantos cortantes! Peligro de cortes</p> <ul style="list-style-type: none"> ▶ Usar guantes de seguridad.

	⚠ ADVERTENCIA
	<p>¡Deslizamiento de aparatos inclinados! Fracturas óseas / lesiones por aplastamiento</p> <ul style="list-style-type: none"> ▶ Asegurar los electrodomésticos contra deslizamientos.



	⚠ PRECAUCIÓN
	<p>¡Riesgo de que se caigan piezas debido a los tornillos aflojados! Peligro de lesiones debido a piezas que caigan.</p> <ul style="list-style-type: none"> ▶ Asegure el componente para que no se caiga.

	ATENCIÓN
	<p>¡Riesgo de que se caigan piezas debido a los tornillos aflojados! Daños en otras partes del aparato o en el domicilio del consumidor, p. ej., en la parte inferior.</p> <ul style="list-style-type: none"> ▶ Asegure el componente para que no se caiga.

	⚠ PELIGRO
	<p>¡Riesgo de descarga eléctrica debido a piezas con tensión! Peligro mortal por descarga eléctrica en caso de reparación inadecuada</p> <ul style="list-style-type: none"> ▶ Las piezas eléctricas deberían ser reparadas por electricistas cualificados. ▶ Después de la reparación, encargar una prueba de seguridad conforme a VDE 0701 o los reglamentos específicos del país.

	⚠ PELIGRO
	<p>¡Riesgo de descarga eléctrica debido a partes con tensión! Muerte por electrocución</p> <ul style="list-style-type: none"> ▶ Desconectar el aparato de la red al menos 60 segundos antes de comenzar con la reparación.

Requisito:

-  El aparato está desconectado del suministro eléctrico.
-  Se han retirado los accesorios del interior del aparato.

4.4.1 Desmontar la bisagra superior de la puerta

1. Deslizar la pieza de soporte debajo de la sección base.

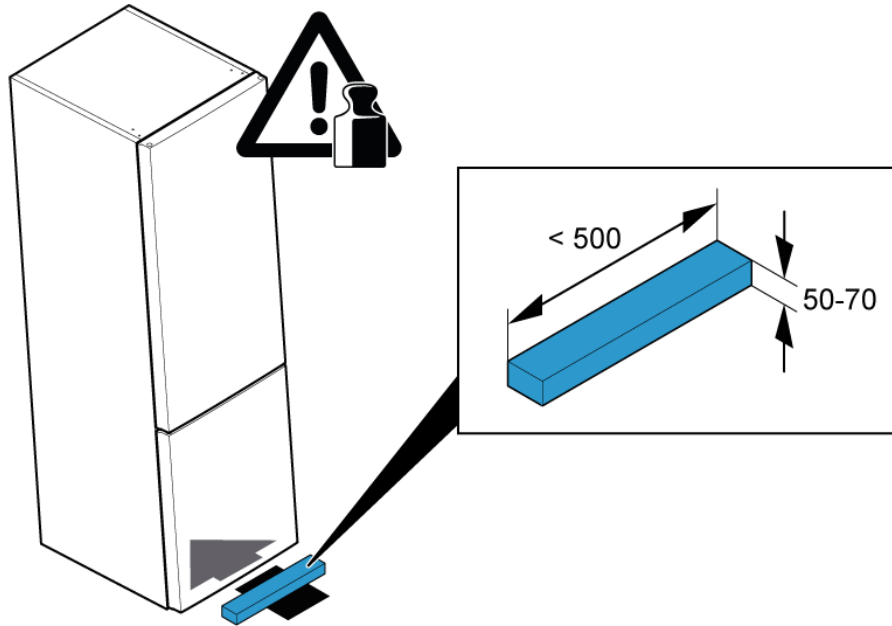

2. 1. Retirar la cubierta de la bisagra superior (1).
2. Desconectar la conexión eléctrica (2).
3. Desatornillar el tornillo de la conexión a tierra (3).

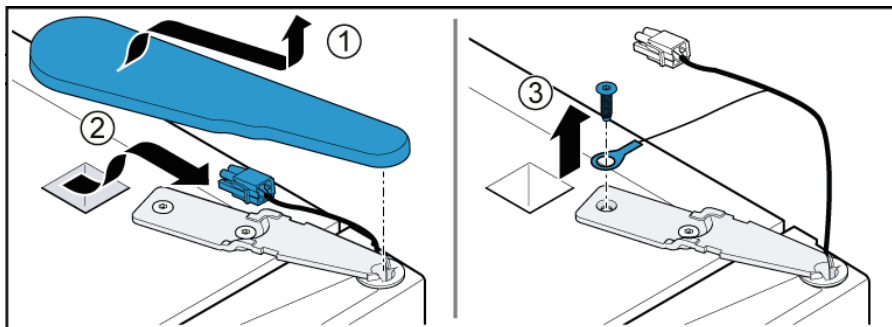

3. 1. Desatornillar el tornillo (1).
2. Retirar la bisagra superior (2).

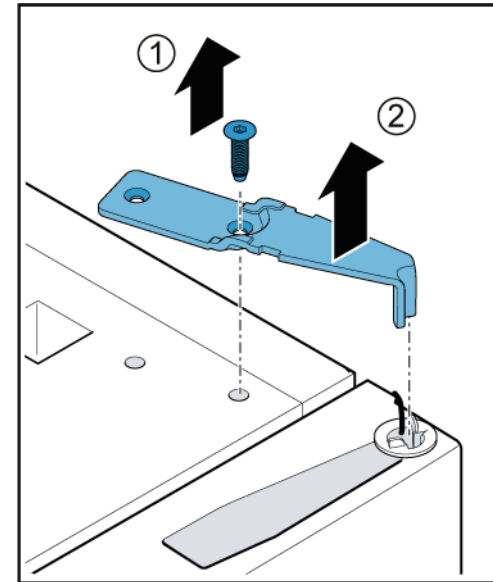

4. Retirar la puerta superior.

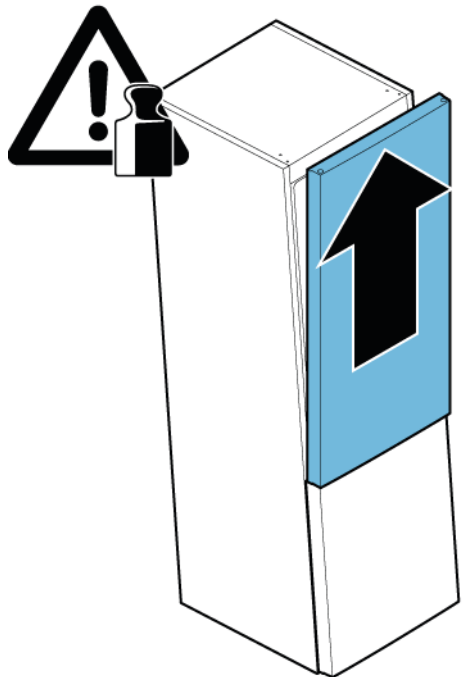

 Se ha retirado la bisagra superior.

4.4.2 Montar la bisagra superior de la puerta

▶ Montar en orden inverso.

4.5 Sustituir la bisagra central de la puerta

Herramientas necesarias:

Punta Torx TX20 6,3 mm (1/4") [00340865]

	⚠ ADVERTENCIA ¡Aparatos pesados y voluminosos! Espalda y lesiones musculares <ul style="list-style-type: none">▶ La operación de extraer la puerta del aparato solo deben llevarla a cabo especialistas formados.▶ Para mover el aparato se necesitan dos personas.▶ Utilizar únicamente herramientas y equipos apropiados.
--	---

	⚠ PRECAUCIÓN ¡Bordes o cantos cortantes! Peligro de cortes <ul style="list-style-type: none">▶ Usar guantes de seguridad.
--	---

	⚠ ADVERTENCIA ¡Deslizamiento de aparatos inclinados! Fracturas óseas / lesiones por aplastamiento <ul style="list-style-type: none">▶ Asegurar los electrodomésticos contra deslizamientos.
--	---

	⚠ PRECAUCIÓN ¡Riesgo de que se caigan piezas debido a los tornillos aflojados! Peligro de lesiones debido a piezas que caigan. <ul style="list-style-type: none">▶ Asegure el componente para que no se caiga.
---	--

	⚠ ATENCION ¡Riesgo de que se caigan piezas debido a los tornillos aflojados! Daños en otras partes del aparato o en el domicilio del consumidor, p. ej., en la parte inferior. <ul style="list-style-type: none">▶ Asegure el componente para que no se caiga.
--	--

Requisito:

- ✔ El aparato está desconectado del suministro eléctrico.
- ✔ Se han retirado los accesorios del interior del electrodoméstico.
- ✔ Se ha retirado la bisagra superior de la puerta.

✔ Se ha retirado la puerta superior.

4.5.1 Desmontar la bisagra central de la puerta

1. Desatornillar los dos tornillos (1).
2. Retirar la bisagra central (2).

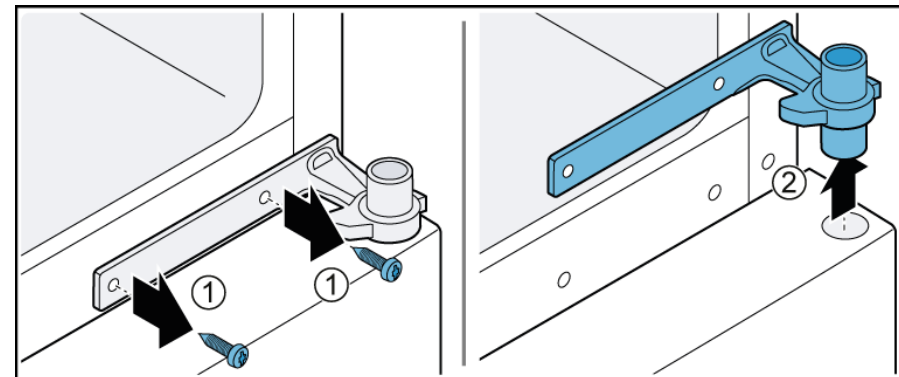

2. Retirar la puerta inferior.

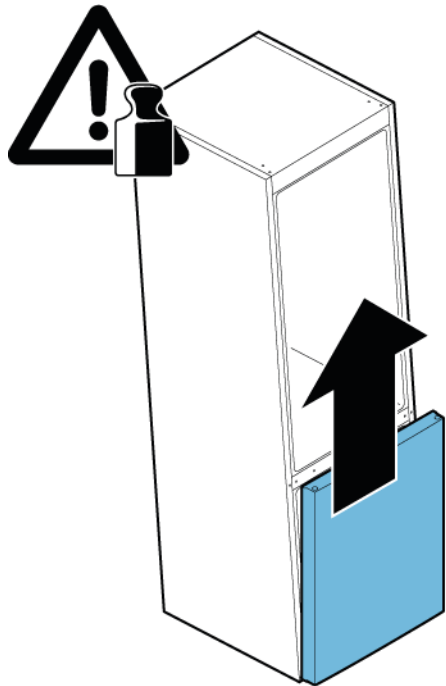

➡ Se ha retirado la bisagra central.

4.5.2 Montar la bisagra central de la puerta

▶ Montar en orden inverso.

4.6 Sustituir la bisagra inferior de la puerta

Herramientas necesarias:

Punta Torx TX20 6,3 mm (1/4") [00340865]

	⚠ ADVERTENCIA ¡Aparatos pesados y voluminosos! Espalda y lesiones musculares <ul style="list-style-type: none">▶ La operación de extraer la puerta del aparato solo deben llevarla a cabo especialistas formados.▶ Para mover el aparato se necesitan dos personas.▶ Utilizar únicamente herramientas y equipos apropiados.
--	---

	⚠ PRECAUCIÓN ¡Bordes o cantos cortantes! Peligro de cortes <ul style="list-style-type: none">▶ Usar guantes de seguridad.
--	---

	⚠ ADVERTENCIA ¡Deslizamiento de aparatos inclinados! Fracturas óseas / lesiones por aplastamiento <ul style="list-style-type: none">▶ Asegurar los electrodomésticos contra deslizamientos.
--	---

	⚠ PRECAUCIÓN ¡Riesgo de que se caigan piezas debido a los tornillos aflojados! Peligro de lesiones debido a piezas que caigan. <ul style="list-style-type: none">▶ Asegure el componente para que no se caiga.
---	--

	⚠ ATENCION ¡Riesgo de que se caigan piezas debido a los tornillos aflojados! Daños en otras partes del aparato o en el domicilio del consumidor, p. ej., en la parte inferior. <ul style="list-style-type: none">▶ Asegure el componente para que no se caiga.
--	--

Requisito:

- ✔ El aparato está desconectado del suministro eléctrico.
- ✔ Se han retirado los accesorios del interior del aparato.
- ✔ Se ha retirado la bisagra superior.

✔ Se ha retirado la bisagra central.

4.6.1 Desmontar la bisagra inferior de la puerta

- ▶ 1. Desatornillar los dos tornillos (1).
- ▶ 2. Retirar la bisagra inferior (2).

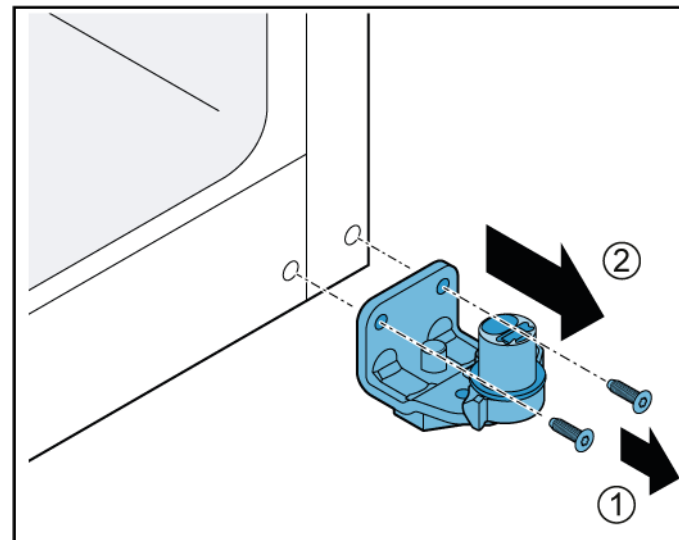

➡ Se ha retirado la bisagra inferior de la puerta.

4.6.2 Montar la bisagra inferior de la puerta

- ▶ Montar en orden inverso.

4.7 Sustituir el estante

Requisito:

- ✔ La puerta está abierta.

4.7.1 Extraer el estante

- ▶ 1. Levantar el estante por detrás (1).
- ▶ 2. Soltar el estante (2).

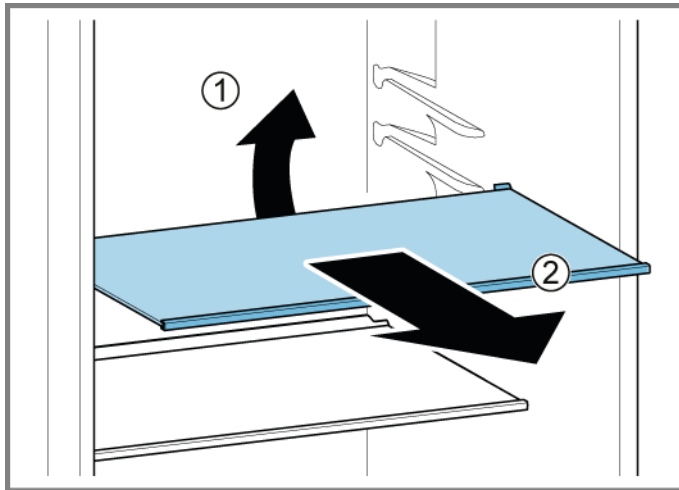

➡ Se ha retirado el estante.

4.7.2 Montar el estante

- ▶ Montar en orden inverso.

4.8 Sustituir la bandeja botellero

Requisito:

- ✔ La puerta está abierta.

4.8.1 Extraer la bandeja botellero

- ▶ Sacar la bandeja botellero.

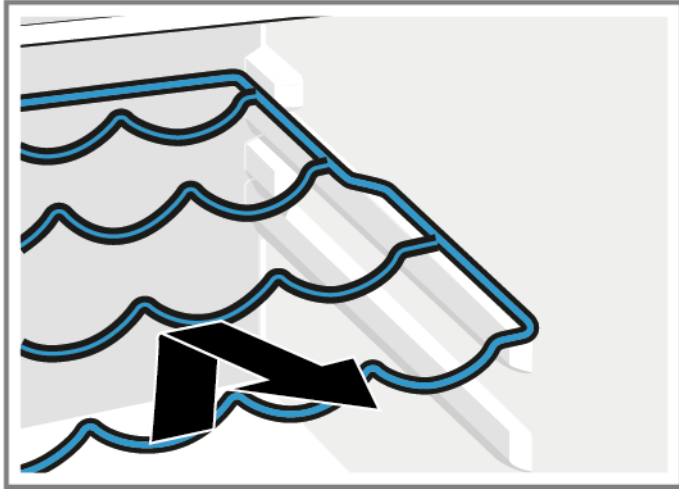

- ➡ Se ha retirado la bandeja botellero.

4.8.2 Montar la bandeja botellero

- ▶ Montar en orden inverso.

4.9 Sustituir el estante de la puerta

Requisito:

- ✔ La puerta está abierta.

4.9.1 Extraer el estante de la puerta

- ▶ Sacar hacia arriba el estante de la puerta.

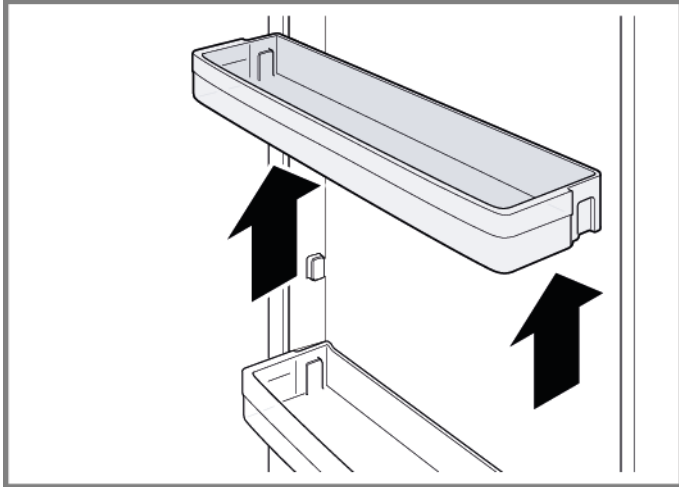

- ➡ Se ha retirado el estante de la puerta.

4.9.2 Montar el estante de la puerta

- ▶ Montar en orden inverso.

4.10 Sustituir el cajón de almacenamiento

Requisito:

- ✔ La puerta está abierta.

4.10.1 Extraer el cajón de almacenamiento

1. Sacar el cajón de almacenamiento tanto como se pueda.
2. 1. Levantar el cajón de almacenamiento por delante (1).
2. Extraer el cajón (2).

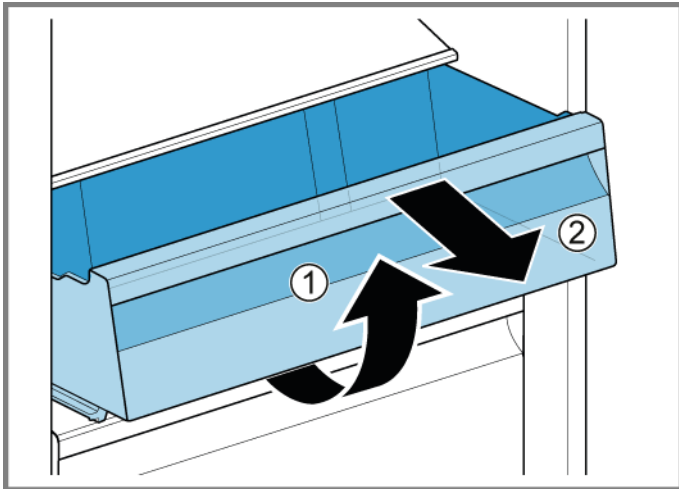

- ➡ Se ha retirado el cajón de almacenamiento.

4.10.2 Montar el cajón de almacenamiento

- ▶ Montar en orden inverso.

4.11 Sustituir el cajón para fruta y verdura

Requisito:

- ✔ La puerta está abierta.

4.11.1 Extraer el cajón para fruta y verdura

1. Sacar el cajón para fruta y verdura tanto como se pueda.
2. 1. Levantar el cajón para fruta y verdura por delante (1).
2. Extraer el cajón (2).

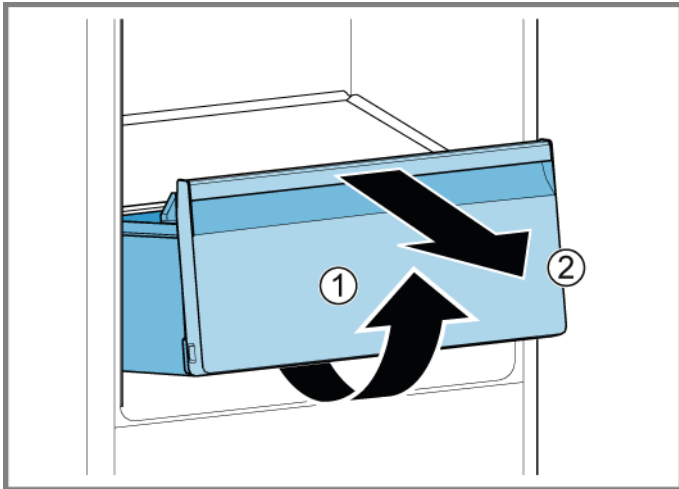

- ➡ Se ha retirado el cajón para fruta y verdura.

4.11.2 Montar el cajón para fruta y verdura

- ▶ Montar en orden inverso.

4.12 Sustituir el estante que está encima del cajón para fruta y verdura

Requisito:

- ✔ La puerta está abierta.
- ✔ [Se ha retirado el cajón para fruta y verdura.→647](#)

4.12.1 Retirar el estante que está encima del cajón para fruta y verdura

1. Tirar del marco hacia arriba y hacia afuera.

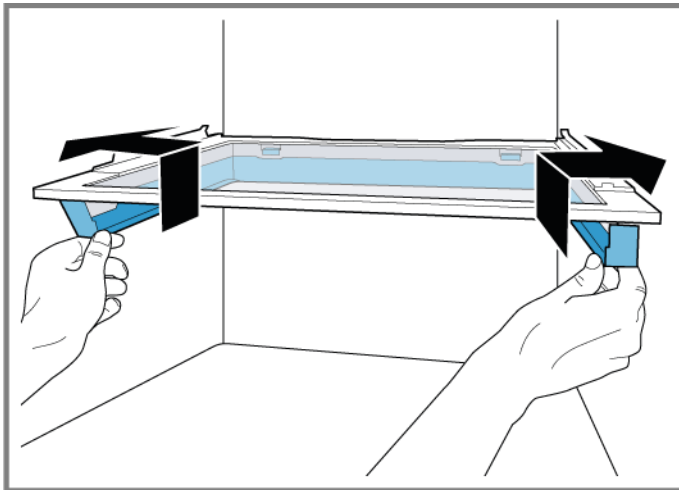

➡ Se han soltado los ganchos laterales.

2. Levantar el marco y deslizarlo hacia atrás.

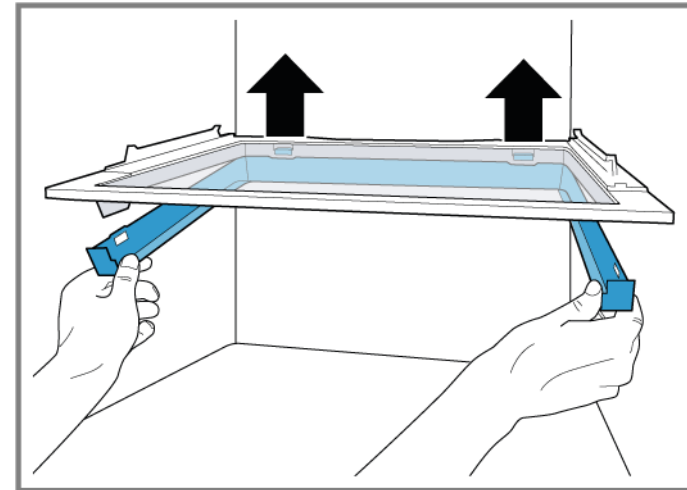

➡ Se han soltado los ganchos traseros.

3. Retirar el marco.
4. Levantar el estante situado sobre el cajón para fruta y verdura e inclinarlo hacia el lado para sacarlo.

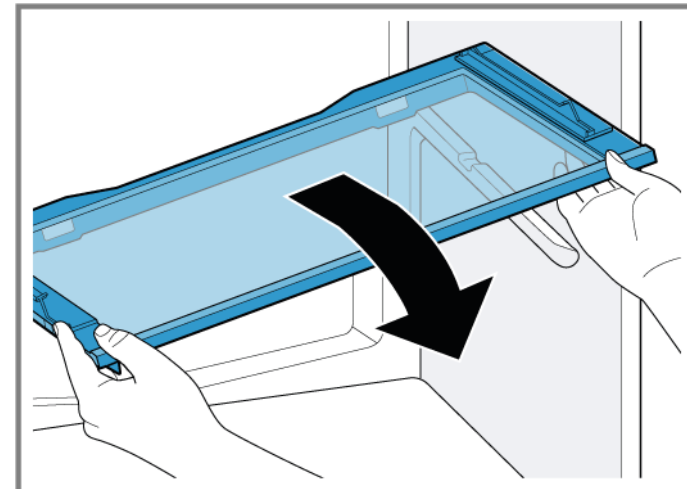

➡ Se ha retirado el estante situado sobre el cajón para fruta y verdura.

4.12.2 Montar el estante sobre el cajón para fruta y verdura

- ▶ Montar en orden inverso.

4.13 Sustituir el cajón de productos congelados

Requisito:

- ✔ La puerta está abierta.

4.13.1 Extraer el cajón de productos congelados

- ▶ 1. Sacar por completo el cajón de productos congelados (1).
- ▶ 2. Extraer el cajón para alimentos (2).

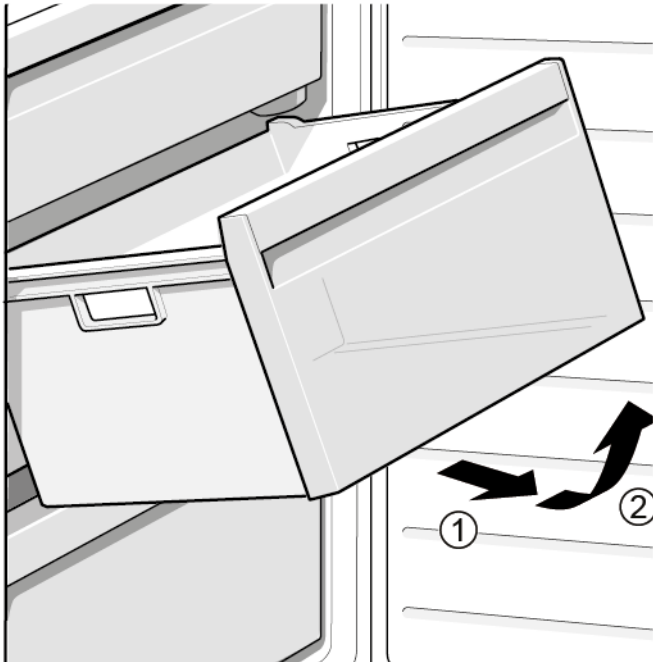

- ➡ Se ha retirado el cajón de productos congelados.

4.13.2 Montar el cajón de productos congelados

- ▶ Montar en orden inverso.

4.14 Sustituir la lámpara LED superior

Herramientas necesarias:

Herramienta especial [00342180]



Su electrodoméstico cuenta con una iluminación LED exenta de mantenimiento.
¡Solo el servicio de atención al cliente o los técnicos autorizados pueden reparar esta iluminación!



PELIGRO

¡Riesgo de descarga eléctrica debido a piezas con tensión!

Peligro mortal por descarga eléctrica en caso de reparación inadecuada

- ▶ Las piezas eléctricas deberían ser reparadas por electricistas cualificados.
- ▶ Después de la reparación, encargar una prueba de seguridad conforme a VDE 0701 o los reglamentos específicos del país.



PELIGRO

¡Riesgo de descarga eléctrica debido a partes con tensión!

Muerte por electrocución

- ▶ Desconectar el aparato de la red al menos 60 segundos antes de comenzar con la reparación.



PRECAUCIÓN

¡Bordes o cantos cortantes!

Peligro de cortes

- ▶ Usar guantes de seguridad.

Requisito:

- ✓ El aparato está desconectado del suministro eléctrico.
- ✓ La puerta está abierta.

4.14.1 Desmontar lámpara LED superior

1. Deslizar la herramienta de desmontaje entre la lámpara LED superior y el revestimiento interior del frigorífico para soltar los ganchos de la lámpara (1).
2. Retirar la lámpara LED superior (2).

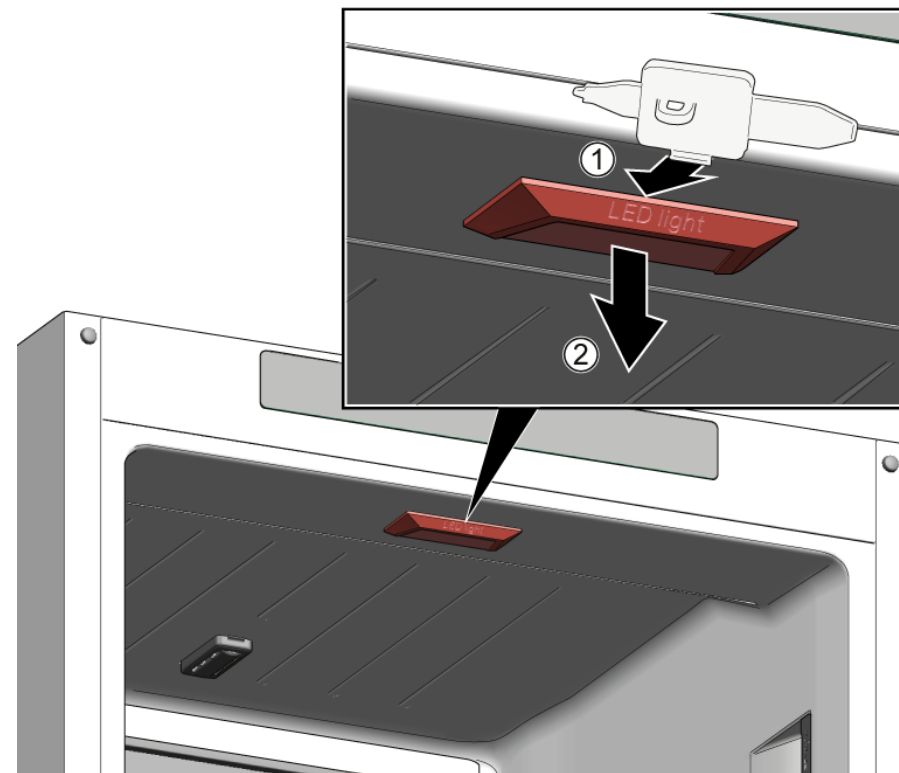

2. Desconectar la conexión eléctrica de la lámpara LED superior.
- ➡ Se ha retirado la lámpara LED superior.

4.14.2 Montar la lámpara LED superior

- ▶ Montar en orden inverso.

4.15 Sustituir la lámpara LED lateral

Herramientas necesarias:

Herramienta especial [00342180]

i Su aparato cuenta con una iluminación LED exenta de mantenimiento. ¡Solo el servicio de atención al cliente o los técnicos autorizados pueden reparar esta iluminación!

⚠ PELIGRO
¡Riesgo de descarga eléctrica debido a piezas con tensión!
 Peligro mortal por descarga eléctrica en caso de reparación inadecuada

- ▶ Las piezas eléctricas deberían ser reparadas por electricistas cualificados.
- ▶ Después de la reparación, encargar una prueba de seguridad conforme a VDE 0701 o los reglamentos específicos del país.

⚠ PELIGRO
¡Riesgo de descarga eléctrica debido a partes con tensión!
 Muerte por electrocución

- ▶ Desconectar el aparato de la red al menos 60 segundos antes de comenzar con la reparación.

⚠ PRECAUCIÓN
¡Bordes o cantos cortantes!
 Peligro de cortes

- ▶ Usar guantes de seguridad.

⚠ ATENCION
¡Riesgo de daños de los componentes sensibles a descargas electrostáticas (ESD)!
 Daños en los componentes

- ▶ Antes de tocar componentes ESD, emplear un sistema de protección electrostática (pulsera de puesta a tierra).
- ▶ No tocar las conexiones ni las pistas conductoras de los módulos.
- ▶ Transportar los componentes ESD únicamente en materiales conductores o en el embalaje original.
- ▶ Mantener los componentes ESD alejados de materiales que puedan cargarse electrostáticamente (por ejemplo, plástico).

Requisito:

- ✓ El aparato está desconectado del suministro eléctrico.
- ✓ La puerta está abierta.
- ✓ Se han retirado los accesorios del interior del frigorífico.

4.15.1 Desmontar la lámpara LED lateral

1. Deslizar la herramienta de desmontaje entre el difusor de la lámpara y la carcasa para soltar el gancho (1).
2. Sacar del todo el difusor de la lámpara (2).
3. Soltar los ganchos de fijación siguientes del difusor de la misma manera.

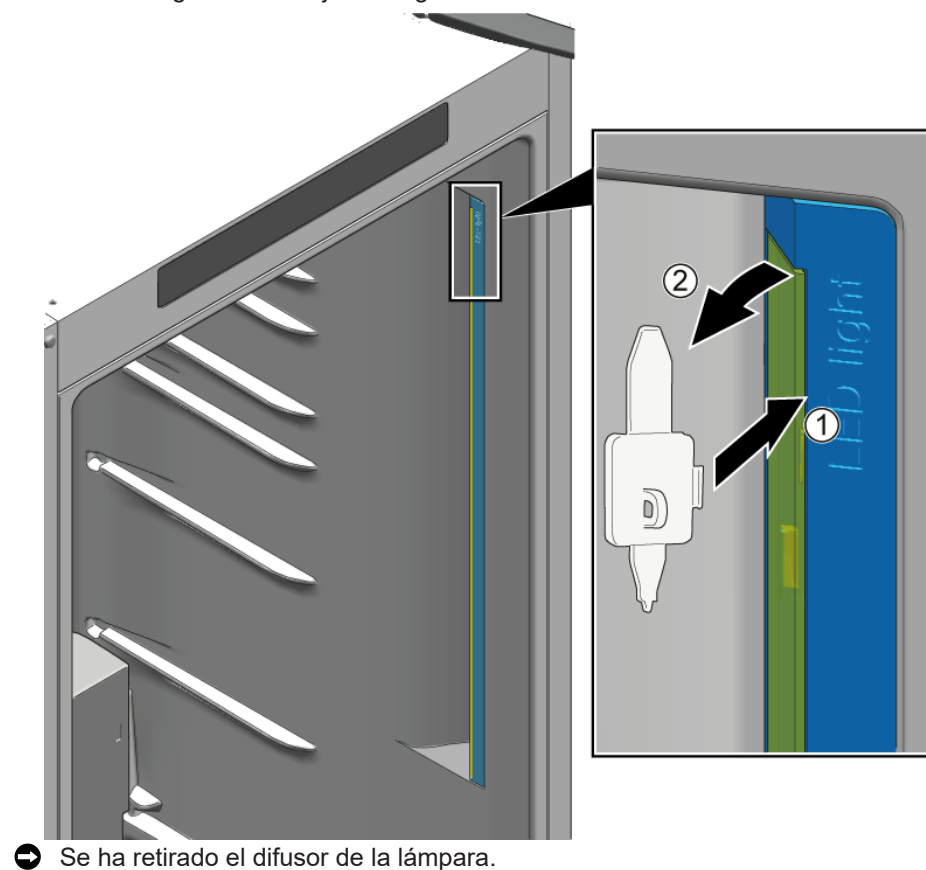

Reparación

1. Presionar el gancho de fijación para soltarlo (1).
2. Mover el módulo LED hacia arriba aprox. 1 cm para desconectar el módulo LED de la toma eléctrica (2).
3. Extraer el módulo LED (3).

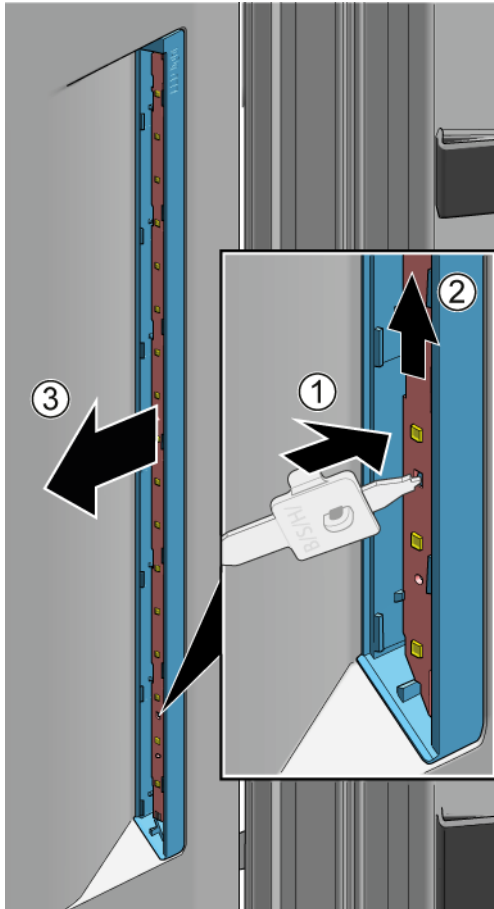

 Se ha extraído la lámpara LED lateral.

4.15.2 Montar la lámpara LED lateral



Debido a que los ganchos del difusor de la lámpara se rompen fácilmente durante el proceso de extracción, el repuesto de la lámpara LED lateral es un conjunto que incluye el módulo LED y el difusor de la lámpara.

1. Deslizar la herramienta de desmontaje entre el difusor de la lámpara y la carcasa para soltar el gancho (1).
2. Sacar del todo el difusor de la lámpara (2).
3. Soltar los ganchos de fijación siguientes del difusor de la misma manera.

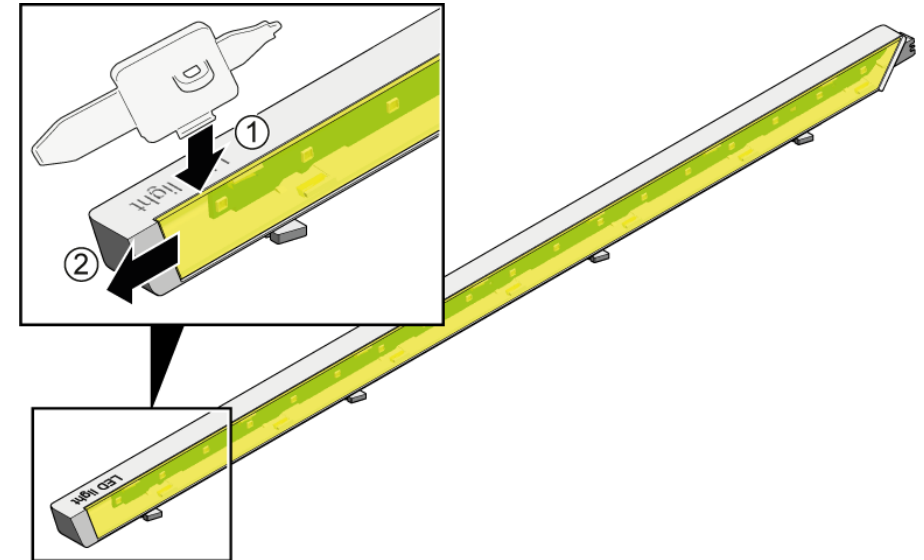

Reparación

2. 1. Presionar el gancho de fijación para soltarlo (1).
2. Deslizar el módulo LED hacia arriba para sacarlo de la carcasa.
3. Desechar la carcasa del módulo LED, que se utiliza por motivos de seguridad en el transporte de piezas de recambio (3).

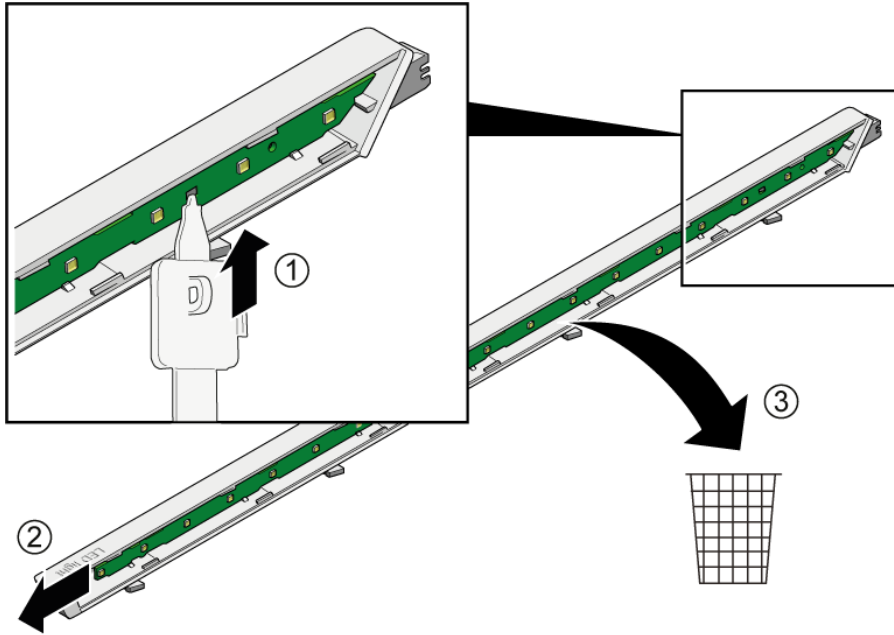

3. Montar el módulo LED y el difusor de la lámpara en orden inverso al del desmontaje.

4.16 Sustituir la lámpara LED del congelador

Herramientas necesarias:

Herramienta especial [00342180]

	<p>Su electrodoméstico cuenta con una iluminación LED exenta de mantenimiento.</p> <p>¡Solo el servicio de atención al cliente o los técnicos autorizados pueden reparar esta iluminación!</p>
---	--

	<p style="text-align: center;">⚠ PELIGRO</p> <p>¡Riesgo de descarga eléctrica debido a piezas con tensión! Peligro mortal por descarga eléctrica en caso de reparación inadecuada</p> <ul style="list-style-type: none"> ▶ Las piezas eléctricas deberían ser reparadas por electricistas cualificados. ▶ Después de la reparación, encargar una prueba de seguridad conforme a VDE 0701 o los reglamentos específicos del país.
--	---

	<p style="text-align: center;">⚠ PELIGRO</p> <p>¡Riesgo de descarga eléctrica debido a partes con tensión! Muerte por electrocución</p> <ul style="list-style-type: none"> ▶ Desconectar el aparato de la red al menos 60 segundos antes de comenzar con la reparación.
--	---

	<p style="text-align: center;">⚠ PRECAUCIÓN</p> <p>¡Bordes o cantos cortantes! Peligro de cortes</p> <ul style="list-style-type: none"> ▶ Usar guantes de seguridad.
---	--

Requisito:

- ✓ El aparato está desconectado del suministro eléctrico.
- ✓ La puerta está abierta.

4.16.1 Desmontar la lámpara LED del congelador

- ▶ 1. Deslizar la herramienta de desmontaje entre la lámpara y la carcasa por el lado de la lámpara para crear un hueco (1).
- ▶ 2. Deslizar la herramienta de desmontaje por el otro lado del gancho de fijación de la lámpara y rotarla hacia delante (2).
- ▶ 3. Retirar la lámpara LED del congelador (3).

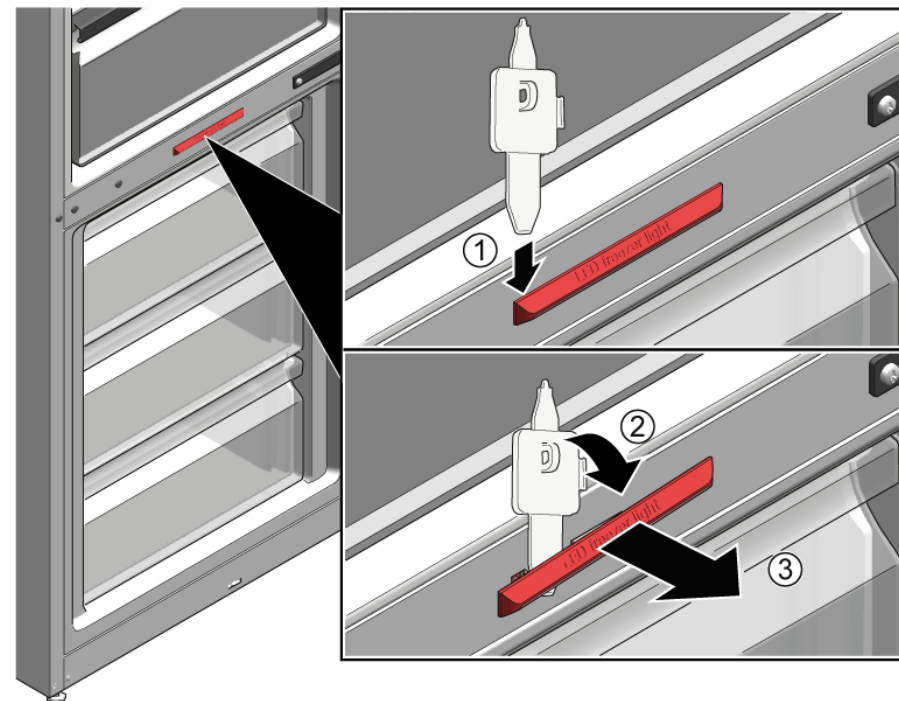





- ➡ La lámpara LED del congelador está desconectada.
- ➡ Se ha extraído la lámpara LED del congelador.

4.16.2 Montar la lámpara LED del congelador

- ▶ Montar en orden inverso.

Reparationsinformation - Kyl-/ fryskombination

 Om detta dokument	657		
1.1 Viktig information.....	657		
1.1.1 Syfte	657		
1.2 Symbolförklaringar.....	657		
1.2.1 Faronivåer	657		
1.2.2 Risksymboler.....	657		
1.2.3 Varningarnas struktur.....	658		
1.2.4 Allmänna symboler.....	658		
 Säkerhet	659		
2.1 Allmänna säkerhetsanvisningar	659		
2.1.1 Alla hushållsmaskiner.....	659		
 Verktyg och hjälpmedel	660		
 Reparation	661		
4.1 Byta dörrpackning.....	661		
4.1.1 Ta bort dörrpackning	661		
4.1.2 Montera dörrpackning	661		
4.2 Byta dörrhandtag.....	664		
4.2.1 Ta bort dörrhandtag	664		
4.2.2 Montera dörrhandtag.....	664		
4.3 Byta dörrens övre gångjärn	665		
4.3.1 Ta bort dörrens övre gångjärn.....	665		
4.3.2 Montera dörrens övre gångjärn	666		
4.4 Byta dörrens övre gångjärn (dörr med display)	667		
4.4.1 Ta bort dörrens övre gångjärn.....	667		
4.4.2 Montera dörrens övre gångjärn	668		
4.5 Byta dörrens mellersta gångjärn	669		
4.5.1 Ta bort dörrens mellersta gångjärn.....	669		
4.5.2 Montera dörrens mellersta gångjärn	670		
4.6 Byta dörrens nedre gångjärn	671		
4.6.1 Ta bort dörrens nedre gångjärn.....	671		
4.6.2 Montera dörrens nedre gångjärn	671		
4.7 Byta hylla	672		
4.7.1 Ta bort hylla.....	672		
4.7.2 Montera hylla.....	672		
4.8 Byta flaskhylla.....	673		
4.8.1 Ta bort flaskhylla	673		
4.8.2 Montera flaskhylla	673		
4.9 Byta dörrhylla.....	674		
4.9.1 Ta bort dörrhylla	674		
4.9.2 Montera dörrhylla	674		
4.10 Byta förvaringsfack.....	675		
4.10.1 Ta bort förvaringsfack	675		
4.10.2 Montera förvaringsfack	675		
4.11 Byta frukt- och grönsakslåda.....	676		
4.11.1 Ta bort frukt- och grönsakslåda	676		
4.11.2 Montera frukt- och grönsakslåda	676		
4.12 Byta hyllan ovanför frukt- och grönsaksfacket	677		
4.12.1 Ta bort hyllan ovanför frukt- och grönsaksfacket.....	677		
4.12.2 Montera hyllan ovanför frukt- och grönsaksfacket	678		
4.13 Byta fack för frysta matvaror	679		
4.13.1 Ta bort fack för frysta matvaror.....	679		
4.13.2 Montera fack för frysta matvaror	679		
4.14 Byta LED-överlampa	680		
4.14.1 Ta bort LED-överlampa.....	680		
4.14.2 Montera LED-överlampa	680		
4.15 Byta LED-sidolampa	681		
4.15.1 Ta bort LED-sidolampa	681		
4.15.2 Montera LED-sidolampa	682		
4.16 Byta LED-fryslampa	684		
4.16.1 Ta bort LED-fryslampa	684		
4.16.2 Montera LED-fryslampa	684		

i Om detta dokument

1.1 Viktig information

1.1.1 Syfte

Dessa reparationstips hjälper kunden att själv reparera maskiner enligt gällande ekodesignbestämmelser (som gäller 03/2021).





De innehåller information om hur vissa reservdelar ska bytas samt tillhörande varningar och risker.

Kontakta vår kundtjänst om du har frågor. Vi åtar oss bara ansvar för skador om reparationstipsen har följts korrekt.

1.2 Symbolförklaringar

1.2.1 Faronivåer

Varningsnivåerna består av en symbol och ett signalord. Signalordet visar hur allvarlig faran är.





Varningsnivå	Innebörd
	Om inte varningsmeddelandet följs kommer det att leda till dödsfall eller allvarliga personskador.
	Om inte varningsmeddelandet följs kan det leda till dödsfall eller allvarliga personskador.
	Om inte varningsmeddelandet följs kan det leda till lättare personskador.
	Om inte varningsmeddelandet följs kan det leda till materialskador.

Grafik 1: Faronivåer



1.2.2 Risksymboler

Risksymboler är symboler som visar typen av fara.

Följande risksymboler används i detta dokument:

Risksymbol	Innebörd
	Allmänt varningsmeddelande
	Fara på grund av elektrisk spänning
	Explosionsrisk
	Fara för skärskador
	Fara för krosskador



i Om detta dokument

Risksymbol	Innebörd
	Fara på grund av heta ytor
	Fara på grund av starka magnetfält
	Fara på grund av icke-joniserande strålning

Grafik 2: Risksymboler

1.2.3 Varningarnas struktur

Varningar i detta dokument har ett standardiserat utseende och en standardiserad struktur.



	<p> FARA!</p> <p>Farans typ och ursprung! Möjliga konsekvenser av att faran/varningen ignoreras.</p> <ul style="list-style-type: none"> ▶ Åtgärder och förbud för att förebygga faran.
--	--





Följande exempel visar en varning som varnar för elstötar från strömförande delar. Det står vilken åtgärd som förebygger faran.

	<p> FARA!</p> <p>Risk för elstötar på grund av strömförande delar! Dödsfall på grund av elstötar</p> <ul style="list-style-type: none"> ▶ Koppla bort maskiner från elförsörjningen minst 60 sekunder innan reparationer påbörjas.
---	---

1.2.4 Allmänna symboler

Följande allmänna symboler används i detta dokument:

Allm. symbol	Innebörd
	Identifiering av ett särskilt tips (text och/eller bild)
	Identifiering av ett enkelt tips (endast text)

Allm. symbol	Innebörd
	Identifiering av en länk till en videohandledning
	Identifiering av verktyg som behövs
	Identifiering av villkor som måste vara uppfyllda
	Identifiering av ett tillstånd (om ..., så ...)
	Identifiering av ett resultat
[Start]	Identifiering av en tangent eller knapp
[00123456]	Identifiering av ett materialnummer
Status	Identifiering av text/fönster som visas (i maskinens display)

Grafik 3: Allmänna symboler

2.1 Allmänna säkerhetsanvisningar

2.1.1 Alla hushållsmaskiner

Risk för elstötar på grund av strömförande delar!

- Fel vid reparationer som berör elkomponenter kan orsaka elstötar!
- Koppla bort maskinen från elnätet minst 60 sekunder innan arbetet påbörjas.
- Låt utföra ett säkerhetstest efter reparationen, i enlighet med VDE 0701 eller landsspecifika regler.

Risk för personskador på grund av vassa kanter!

- Använd skyddshandskar.

Risk för krosskador vid reparation, underhåll, felsökning och service på grund av tunga och rörliga komponenter

- Använd skyddsskor.
- Säkra tunga komponenter så att de inte faller ner.
- Stick inte in kroppsdelar i rörliga komponenter.

Risk för maskinens säkerhet/funktion!

- Använd endast originaldelar.

Risk för skador på komponenter känsliga för statisk elektricitet (ESD)!

- Rör inte modulerna samt anslutningar och strömförande ledningar.

Verkt yg och hj alpmedel

Beteckning	Detaljer	Bilder
Torxbits TX20 [00340865]	6,3 mm (1/4")	
Specialverkt�yg [00342180]		

4.1 Byta dörrpackning

Förutsättning:

- ✔ Dörren är öppen.

4.1.1 Ta bort dörrpackning

1. Lossa dörrpackningen från spåret i högra och vänstra hörnet.

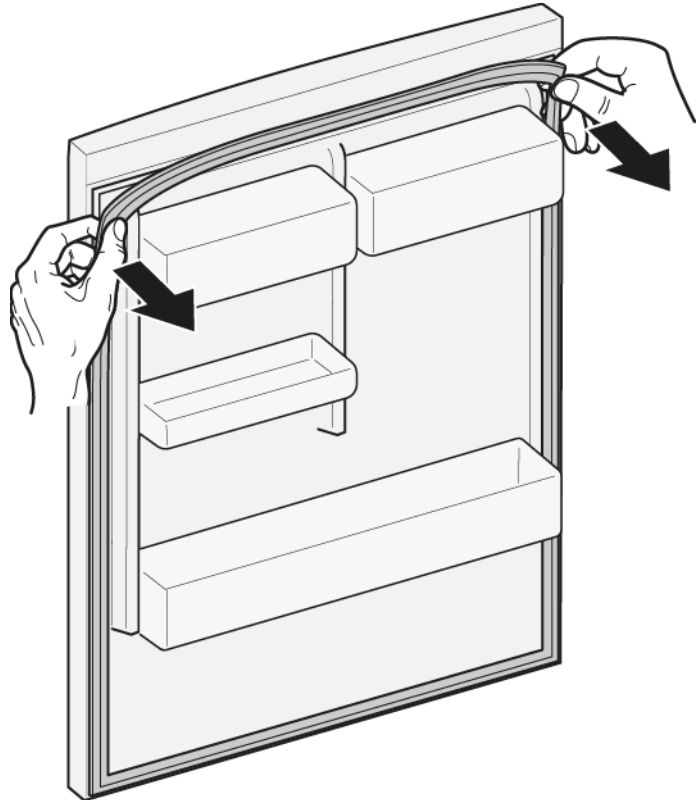

2. Dra ut dörrpackningen från spåret.

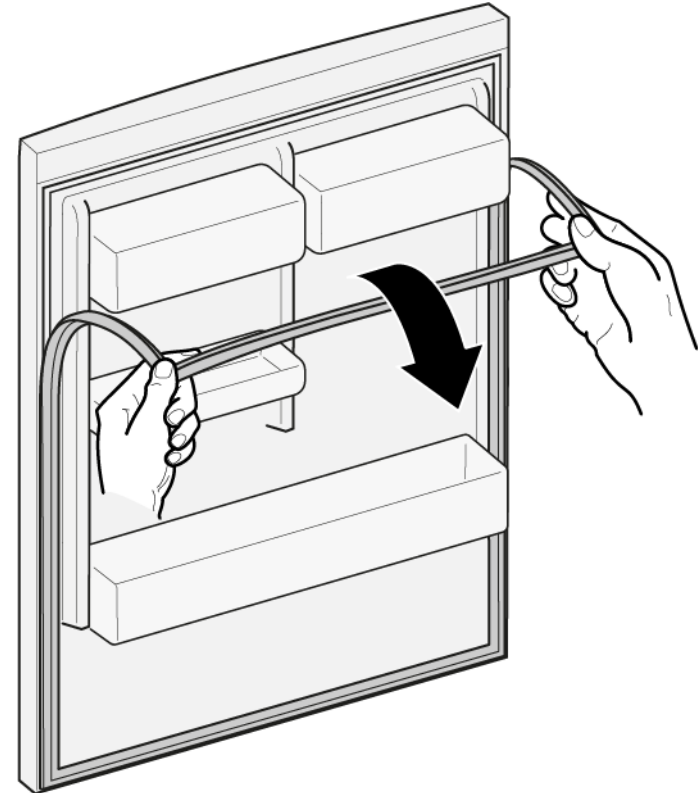

- ➡ Dörrpackningen har tagits bort.

4.1.2 Montera dörrpackning



Den nya dörrpackningens tjocklek kan avvika något från den gamla dörrpackningens tjocklek. Detta kommer inte påverka stängningsegenskaperna eller funktionen långsiktigt.

Om apparaten har justerbara gångjärn eller gångjärnsfästen kan du optimera stängningsegenskaperna senare.

Små sidohål i dörrpackningen fyller en funktion (krävs för ventilation). Dessa utgör inga tillverkningsfel.

Reparation

1. Kontrollera om spåret för packningen har skador.

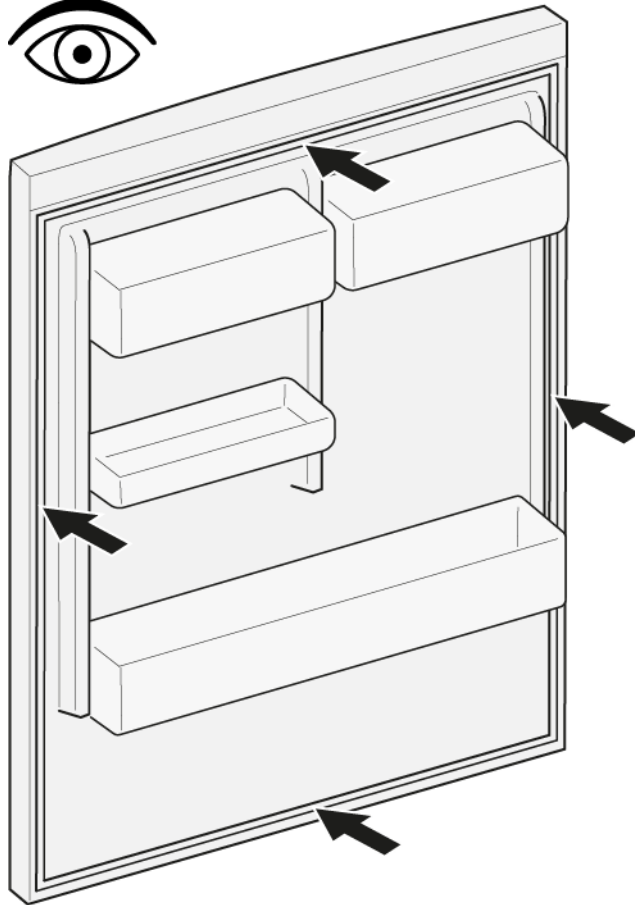

4. Tryck in packningens hörn längst upp och längst ner i spåret.

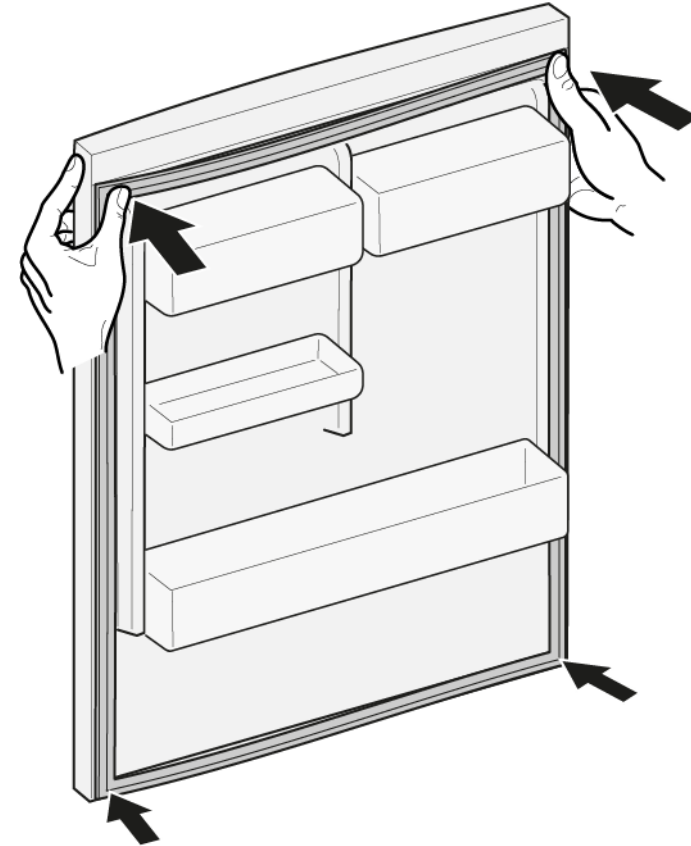

2.  Om spåret för packningen är skadat:
 - Kontakta kundtjänst.

3.  Viss deformation av dörrpackningen är normalt och påverkar inte packningens funktion. Det rekommenderas att man sträcker dörrpackningen innan den sätts in i apparaten.

Värm dörrpackningen med en hårtork eller hett vatten och forma om den med händerna.

Reparation

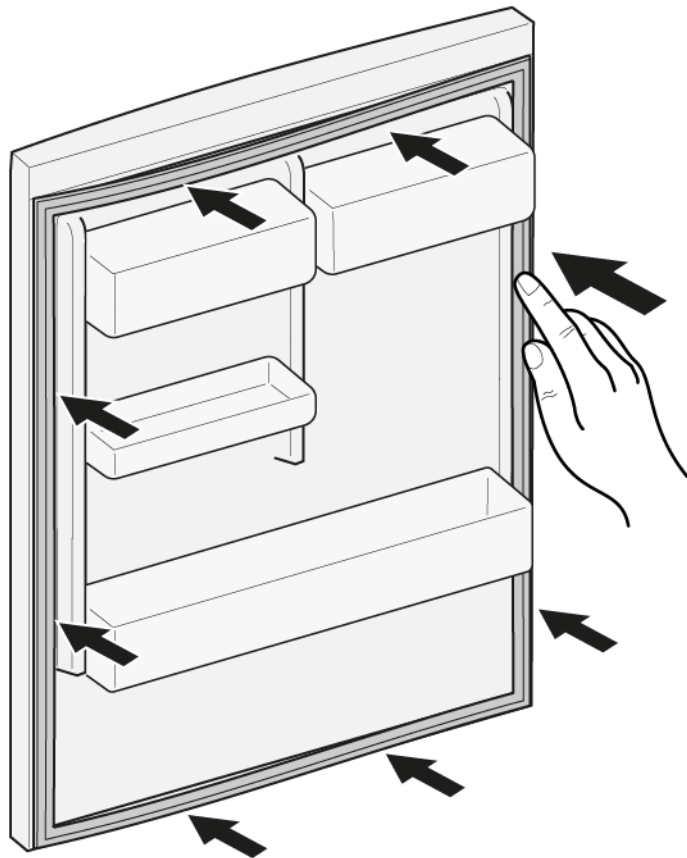

5. Tryck in hela packningen i spåret bit för bit.





 Dörrpackningen är monterad.

4.2 Byta dörrhandtag

Nödvändiga verktyg:

-  Torxbits TX20 6,3 mm (1/4") [00340865]
-  Spårskruvmejsel Blad 10 mm x 1,6 mm x 200 mm

Förutsättning:

-  Apparaten är bortkopplad från strömförsörjning.
-  Dörren är öppen.

4.2.1 Ta bort dörrhandtag

- ▶ 1. Ta bort de två skruvhättorna (1).
- ▶ 2. Skruva ur de två skruvarna (2).
- ▶ 3. Ta bort dörrhandtaget (3).

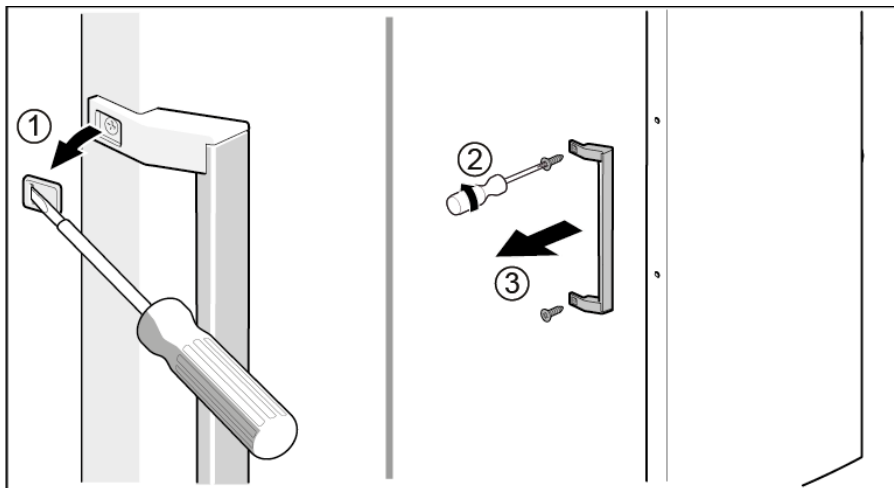

 Dörrhandtaget har tagits bort.



Dörrhandtaget för den andra dörren kan tas bort på samma sätt.

4.2.2 Montera dörrhandtag

- ▶ Montera i omvänd ordning.

4.3 Byta dörrens övre gångjärn

Nödvändiga verktyg:

Torxbits TX20

6,3 mm (1/4")

[00340865]

	<p>⚠ VARNING!</p> <p>Tunga och skrymmande apparater! Rygg- och muskelskador</p> <ul style="list-style-type: none"> ▶ Låt endast utbildad personal ta bort dörren från apparaten. ▶ Det krävs två personer för att flytta apparaten. ▶ Använd endast passande verktyg och utrustning.
	<p>⚠ FÖRSIKTIGT!</p> <p>Vassa kanter! Skärskador</p> <ul style="list-style-type: none"> ▶ Använd skyddshandskar.
	<p>⚠ VARNING!</p> <p>Lutande maskiner kan glida! Frakturer/krosskador</p> <ul style="list-style-type: none"> ▶ Säkra maskiner så att de inte kan glida.
	<p>⚠ FÖRSIKTIGT!</p> <p>Risk för fallande delar på grund av lossade skruvar! Personskador på grund av fallande delar.</p> <ul style="list-style-type: none"> ▶ Säkra komponenter så att de inte faller ner.
	<p>OBS!</p> <p>Risk för fallande delar på grund av lossade skruvar! Materiella skador på andra delar av maskinen eller i kundens hem, t.ex. vid botten.</p> <ul style="list-style-type: none"> ▶ Säkra komponenter så att de inte faller ner.

Förutsättning:

- ✓ Apparaten är bortkopplad från strömförsörjning.
- ✓ Tillbehör inuti apparaten har tagits bort.

4.3.1 Ta bort dörrens övre gångjärn

1. För in stöddelen under sockeldelen.

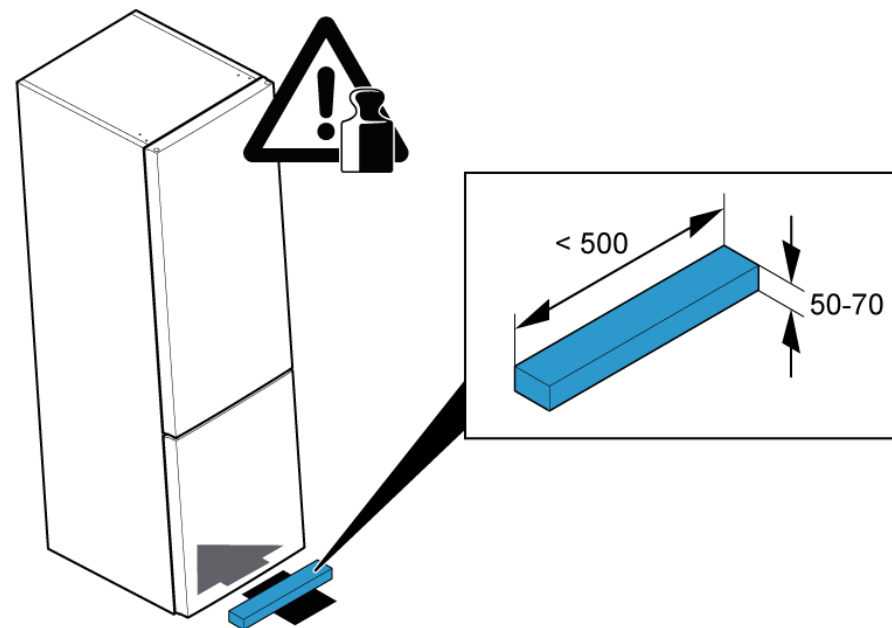

2. 1. Ta bort det övre gångjärnsskyddet (1).
2. Skruva ut de två skruvarna (2).
3. Ta bort det övre gångjärnet (3).

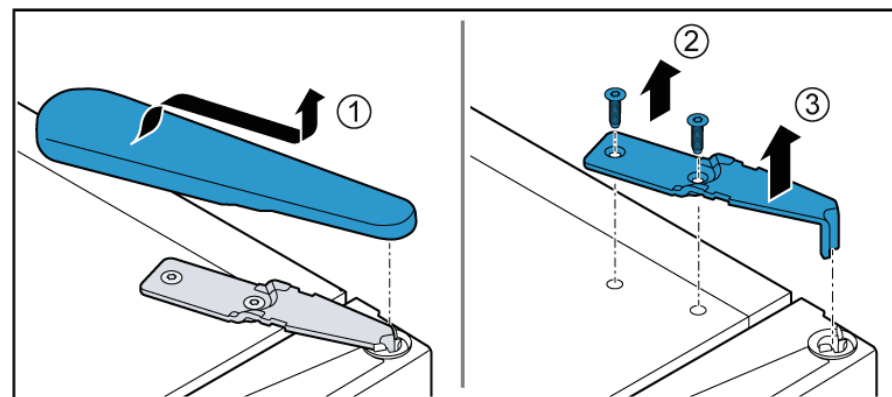

3. Ta bort den övre dörren.

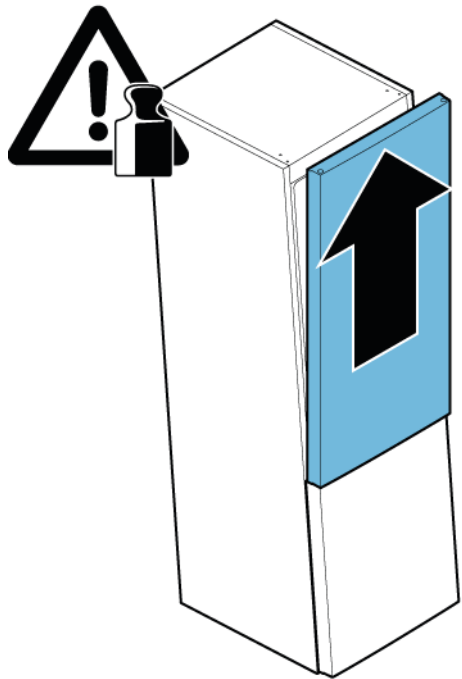

 Det övre gångjärnet har nu tagits bort.

4.3.2 Montera dörrens övre gångjärn

► Montera i omvänd ordning.

4.4 Byta dörrens övre gångjärn (dörr med display)

Nödvändiga verktyg:

Torxbits TX20

6,3 mm (1/4")

[00340865]

	⚠ VARNING! Tunga och skrymmande apparater! Rygg- och muskelskador ▶ Låt endast utbildad personal ta bort dörren från apparaten. ▶ Det krävs två personer för att flytta apparaten. ▶ Använd endast passande verktyg och utrustning.
	⚠ FÖRSIKTIGT! Vassa kanter! Skärskador ▶ Använd skyddshandskar.
	⚠ VARNING! Lutande maskiner kan glida! Frakturer/krosskador ▶ Säkra maskiner så att de inte kan glida.
	⚠ FÖRSIKTIGT! Risk för fallande delar på grund av lossade skruvar! Personskador på grund av fallande delar. ▶ Säkra komponenter så att de inte faller ner.
	OBS! Risk för fallande delar på grund av lossade skruvar! Materiella skador på andra delar av maskinen eller i kundens hem, t.ex. vid botten. ▶ Säkra komponenter så att de inte faller ner.

	⚠ FARA! Risk för elstötar på grund av strömförande delar! Livsfara på grund av elstötar vid felaktiga reparationer ▶ Elektriska delar ska repareras av behörig elektriker. ▶ Låt utföra ett säkerhetstest efter reparationen, i enlighet med VDE 0701 eller landsspecifika regler.
---	--

	⚠ FARA! Risk för elstötar på grund av strömförande delar! Dödsfall på grund av elstötar ▶ Koppla bort maskiner från elförsörjningen minst 60 sekunder innan reparationer påbörjas.
---	---

Förutsättning:

- ✓ Apparaten är bortkopplad från strömförsörjning.
- ✓ Tillbehör inuti apparaten har tagits bort.

4.4.1 Ta bort dörrens övre gångjärn

1. För in stöddelen under sockeldelen.

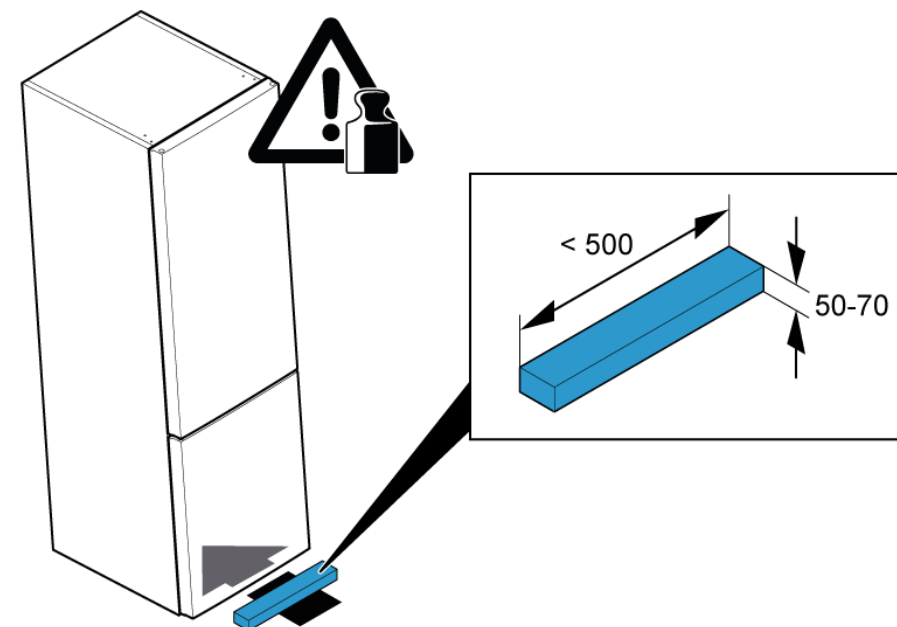

Reparation

1. Ta bort det övre gångjärnsskyddet (1).
2. Lossa elanslutningen (2).
3. Skruva ut jordningsskruven (3).

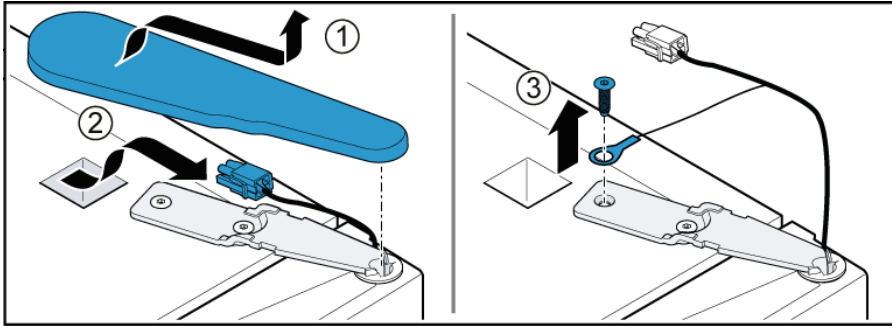

1. Skruva ut skruven (1).
2. Ta bort det övre gångjärnet (2).

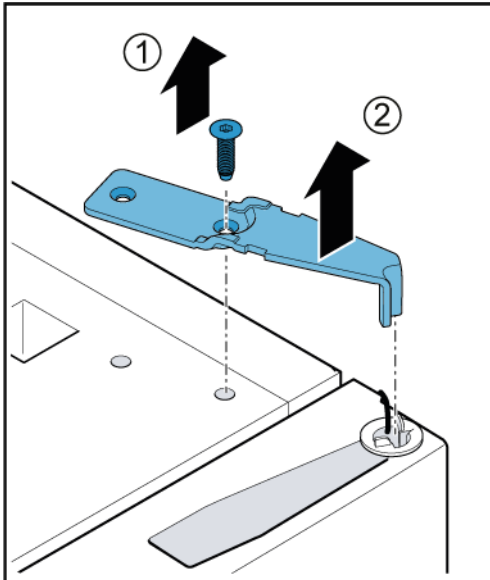

4. Ta bort den övre dörren.

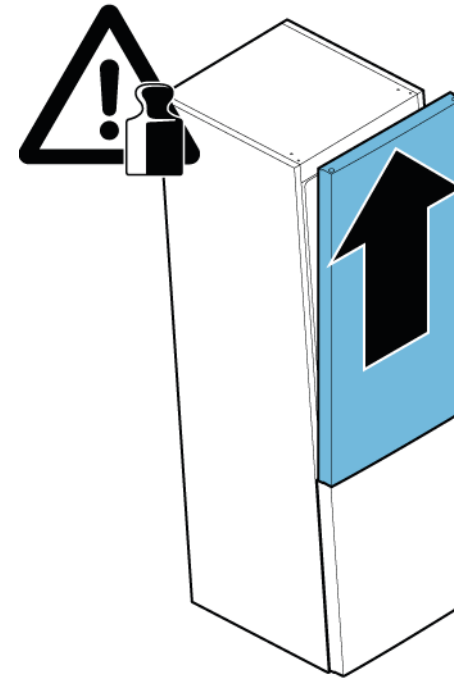

➡ Det övre gångjärnet har nu tagits bort.

4.4.2 Montera dörrens övre gångjärn

- ▶ Montera i omvänd ordning.

4.5 Byta dörrens mellersta gångjärn

Nödvändiga verktyg:

Torxbits TX20

6,3 mm (1/4")

[00340865]

	⚠ VARNING!
	<p>Tunga och skrymmande apparater! Rygg- och muskelskador</p> <ul style="list-style-type: none"> ▶ Låt endast utbildad personal ta bort dörren från apparaten. ▶ Det krävs två personer för att flytta apparaten. ▶ Använd endast passande verktyg och utrustning.

	⚠ FÖRSIKTIGT!
	<p>Vassa kanter! Skärskador</p> <ul style="list-style-type: none"> ▶ Använd skyddshandskar.

	⚠ VARNING!
	<p>Lutande maskiner kan glida! Frakturer/krosskador</p> <ul style="list-style-type: none"> ▶ Säkra maskiner så att de inte kan glida.

	⚠ FÖRSIKTIGT!
	<p>Risk för fallande delar på grund av lossade skruvar! Personskador på grund av fallande delar.</p> <ul style="list-style-type: none"> ▶ Säkra komponenter så att de inte faller ner.

	OBS!
	<p>Risk för fallande delar på grund av lossade skruvar! Materiella skador på andra delar av maskinen eller i kundens hem, t.ex. vid botten.</p> <ul style="list-style-type: none"> ▶ Säkra komponenter så att de inte faller ner.

Förutsättning:

- ✔ Apparaten är bortkopplad från strömförsörjning.
- ✔ Invändiga tillbehör i apparaten har tagits bort.
- ✔ Dörrens övre gångjärn har tagits bort.
- ✔ Den övre dörren har tagits bort.

4.5.1 Ta bort dörrens mellersta gångjärn

1. 1. Skruva ut de två skruvarna (1).
2. Ta bort det mellersta gångjärnet (2).

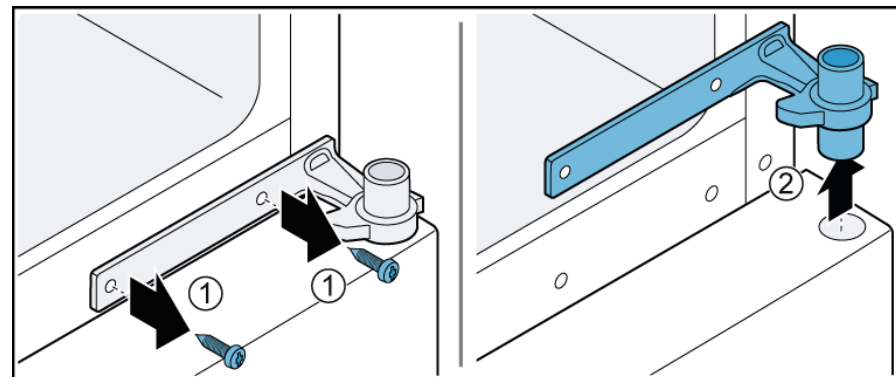

2. Ta bort den nedre dörren.

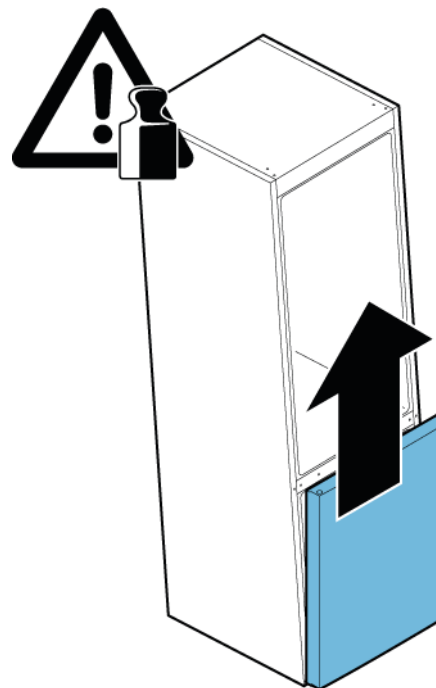

- ➡ Det mellersta gångjärnet har tagits bort.

4.5.2 Montera dörrens mellersta gångjärn

- ▶ Montera i omvänd ordning.

4.6 Byta dörrens nedre gångjärn

Nödvändiga verktyg:

Torxbits TX20

6,3 mm (1/4")

[00340865]

	⚠ VARNING!
	Tunga och skrymmande apparater! Rygg- och muskelskador <ul style="list-style-type: none">▶ Låt endast utbildad personal ta bort dörren från apparaten.▶ Det krävs två personer för att flytta apparaten.▶ Använd endast passande verktyg och utrustning.

	⚠ FÖRSIKTIGT!
	Vassa kanter! Skärskador <ul style="list-style-type: none">▶ Använd skyddshandskar.

	⚠ VARNING!
	Lutande maskiner kan glida! Frakturer/krosskador <ul style="list-style-type: none">▶ Säkra maskiner så att de inte kan glida.

	⚠ FÖRSIKTIGT!
	Risk för fallande delar på grund av lossade skruvar! Personskador på grund av fallande delar. <ul style="list-style-type: none">▶ Säkra komponenter så att de inte faller ner.

	OBS!
	Risk för fallande delar på grund av lossade skruvar! Materiella skador på andra delar av maskinen eller i kundens hem, t.ex. vid botten. <ul style="list-style-type: none">▶ Säkra komponenter så att de inte faller ner.

Förutsättning:

- ✓ Apparaten är bortkopplad från strömförsörjning.
- ✓ Tillbehör inuti apparaten har tagits bort.
- ✓ Det övre gångjärnet har tagits bort.
- ✓ Det mellersta gångjärnet har tagits bort.

4.6.1 Ta bort dörrens nedre gångjärn

- ▶ 1. Skruva ut de två skruvarna (1).
- ▶ 2. Ta bort det nedre gångjärnet (2).

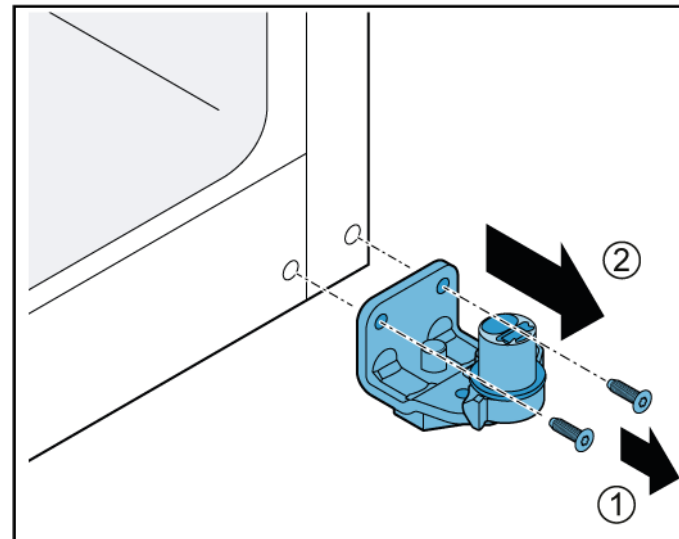

➡ Dörrens nedre gångjärn har tagits bort.

4.6.2 Montera dörrens nedre gångjärn

- ▶ Montera i omvänd ordning.

4.7 Byta hylla

Förutsättning:

- ✔ Dörren är öppen.

4.7.1 Ta bort hylla

- ▶ 1. Lyft upp hyllan baktill (1).
- ▶ 2. Lossa hyllan (2).

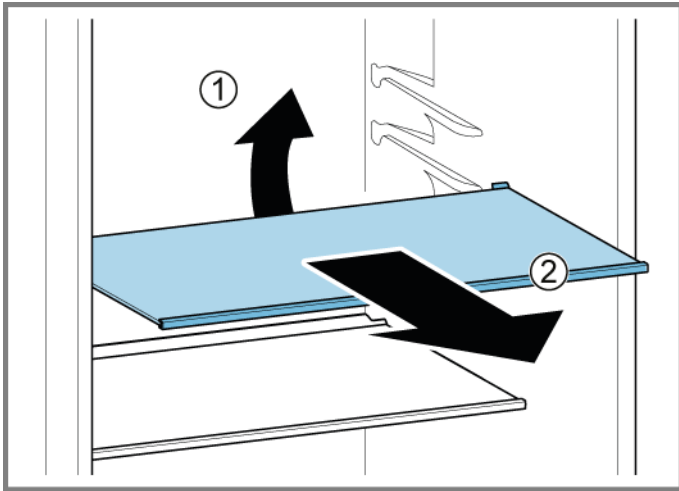

➡ Hyllan har nu tagits bort.

4.7.2 Montera hylla

- ▶ Montera i omvänd ordning.

4.8 Byta flaskhylla

Förutsättning:

- ✓ Dörren är öppen.

4.8.1 Ta bort flaskhylla

- ▶ Dra ut flaskhyllan.

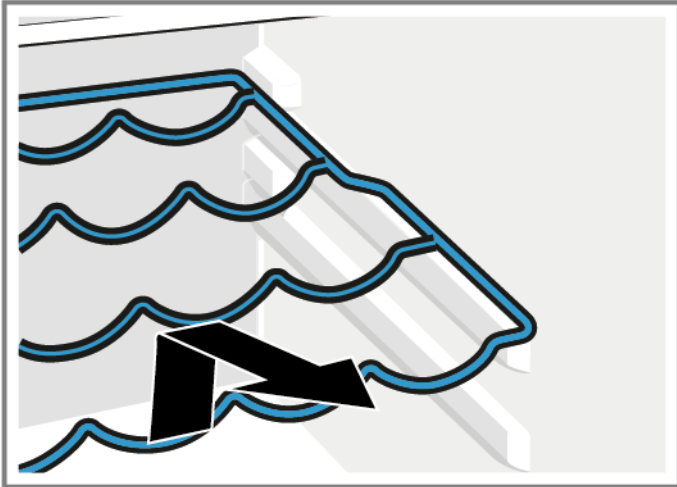

- ➡ Flaskhyllan har tagits bort.

4.8.2 Montera flaskhylla

- ▶ Montera i omvänd ordning.

4.9 Byta dörrhylla

Förutsättning:

- ✔ Dörren är öppen.

4.9.1 Ta bort dörrhylla

- ▶ Lyft dörrhyllan uppåt.

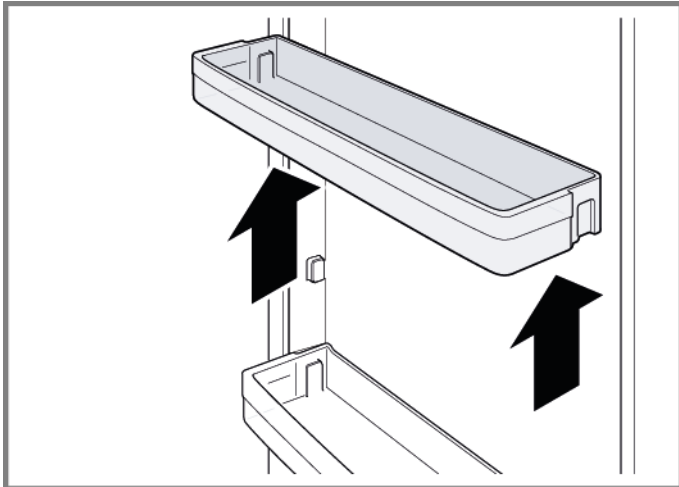

➡ Dörrhyllan har tagits bort.

4.9.2 Montera dörrhylla

- ▶ Montera i omvänd ordning.

4.10 Byta förvaringsfack

Förutsättning:

- ✓ Dörren är öppen.

4.10.1 Ta bort förvaringsfack

1. Dra ut förvaringsfacket så långt det går.
2. 1. Lyft upp förvaringsfacket framtill (1).
2. Ta bort facket (2).

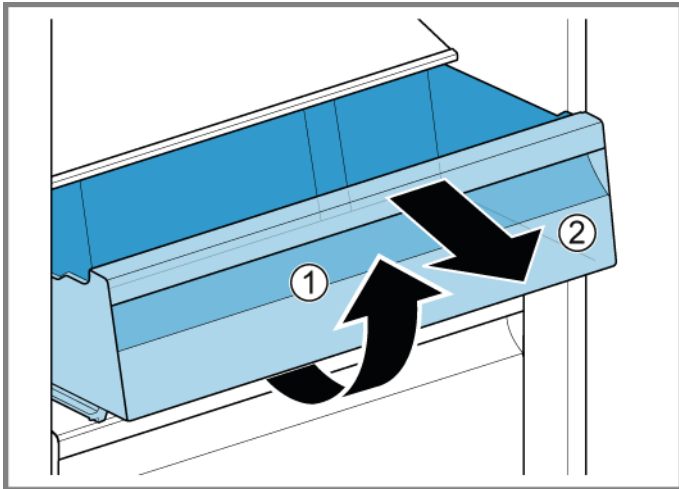

- ➔ Förvaringsfacket har tagits bort.

4.10.2 Montera förvaringsfack

- ▶ Montera i omvänd ordning.

4.11 Byta frukt- och grönsakslåda

Förutsättning:

- ✓ Dörren är öppen.

4.11.1 Ta bort frukt- och grönsakslåda

1. Dra ut frukt- och grönsaksfacket så långt det går.
2. 1. Lyft upp frukt- och grönsaksfacket framtill (1).
2. Ta bort facket (2).

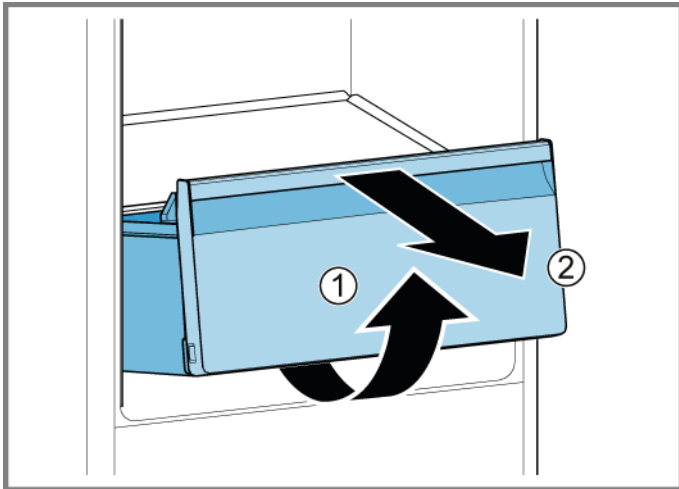

- ➡ Frukt- och grönsaksfacket har tagits bort.

4.11.2 Montera frukt- och grönsakslåda

- ▶ Montera i omvänd ordning.

4.12 Byta hyllan ovanför frukt- och grönsaksfacket

Förutsättning:

- ✔ Dörren är öppen.
- ✔ [Frukt- och grönsaksfacket har tagits bort.](#) → 676

4.12.1 Ta bort hyllan ovanför frukt- och grönsaksfacket

1. Tryck tätningsramen uppåt och utåt.

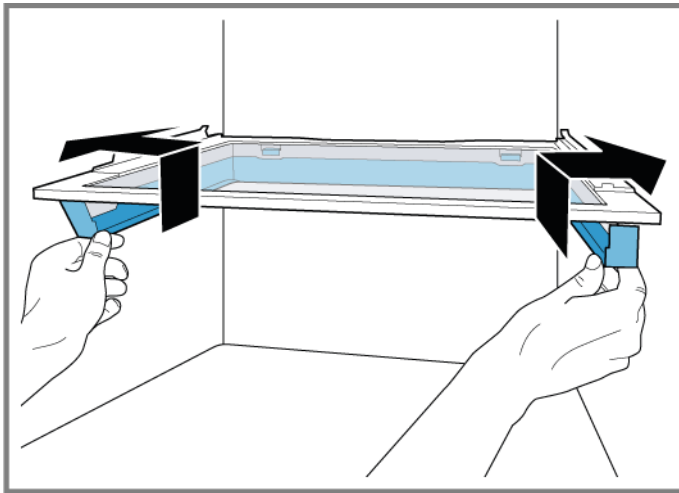

- ➡ Sidohakarna har lossats.

2. Lyft upp tätningsramen och för den bakåt.

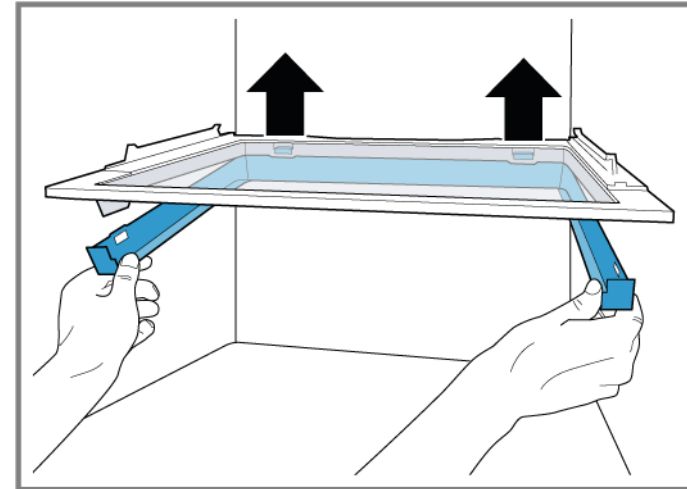

- ➡ Hakarna bak har lossats.

3. Ta bort tätningsramen.
4. Lyft upp hyllan ovanför frukt- och grönsaksfacket och sväng ut den åt sidan.

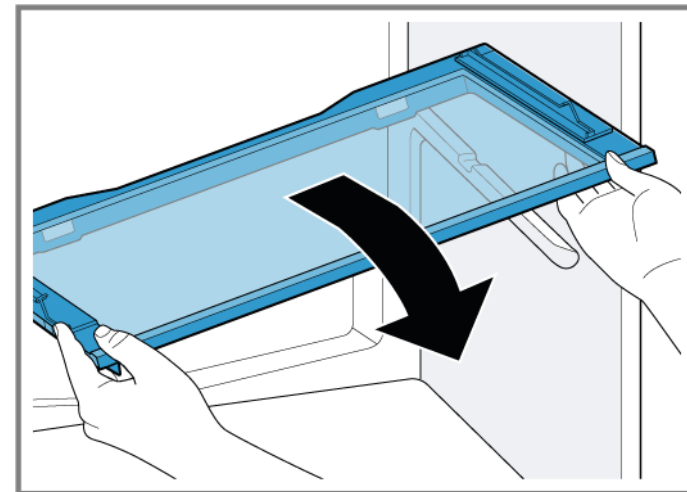

- ➡ Hyllan ovanför frukt- och grönsaksfacket har tagits bort.

4.12.2 Montera hyllan ovanför frukt- och grönsaksfacket

- ▶ Montera i omvänd ordning.

4.13 Byta fack för frysta matvaror

Förutsättning:

- ✔ Dörren är öppen.

4.13.1 Ta bort fack för frysta matvaror

- ▶ 1. Dra ut facket för frysta matvaror helt (1).
- ▶ 2. Ta bort facket för matvaror (2).

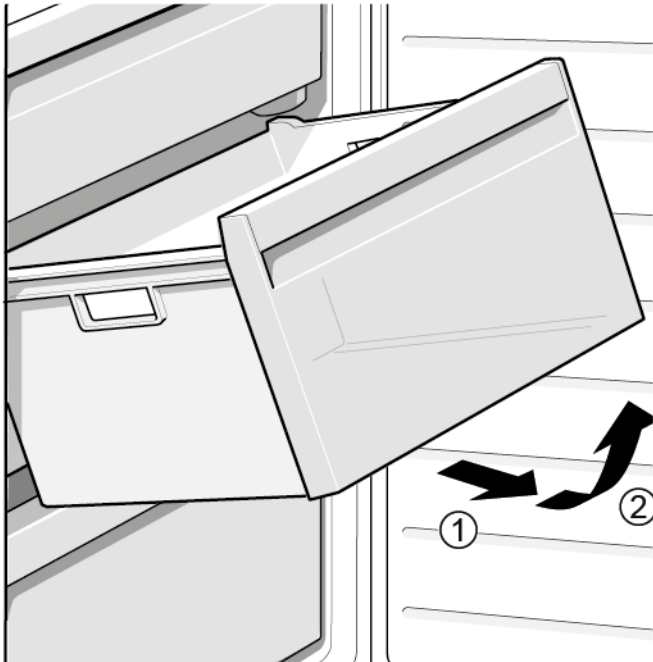

- ➡ Facket för frysta matvaror har tagits bort.

4.13.2 Montera fack för frysta matvaror

- ▶ Montera i omvänd ordning.

4.14 Byta LED-överlampa

Nödvändiga verktyg:

Specialverktyg

[00342180]



Apparaten har en underhållsfri LED-lampa. Sådana lampor får bara bytas av kundtjänsten eller av auktoriserade tekniker!



FARA!

Risk för elstötar på grund av strömförande delar!

Livsfara på grund av elstötar vid felaktiga reparationer

- ▶ Elektriska delar ska repareras av behörig elektriker.
- ▶ Låt utföra ett säkerhetstest efter reparationen, i enlighet med VDE 0701 eller landsspecifika regler.



FARA!

Risk för elstötar på grund av strömförande delar!

Dödsfall på grund av elstötar

- ▶ Koppla bort maskiner från elförsörjningen minst 60 sekunder innan reparationer påbörjas.



FÖRSIKTIGT!

Vassa kanter!

Skärskador

- ▶ Använd skyddshandskar.

Förutsättning:

- ✓ Apparaten är bortkopplad från strömförsörjning.
- ✓ Dörren är öppen.

4.14.1 Ta bort LED-överlampa

1. För demonteringsverktyget mellan LED-överlampan och kylutrymmets innerlinjer för att lossa lamphakarna (1).
2. Ta bort LED-överlampan (2).

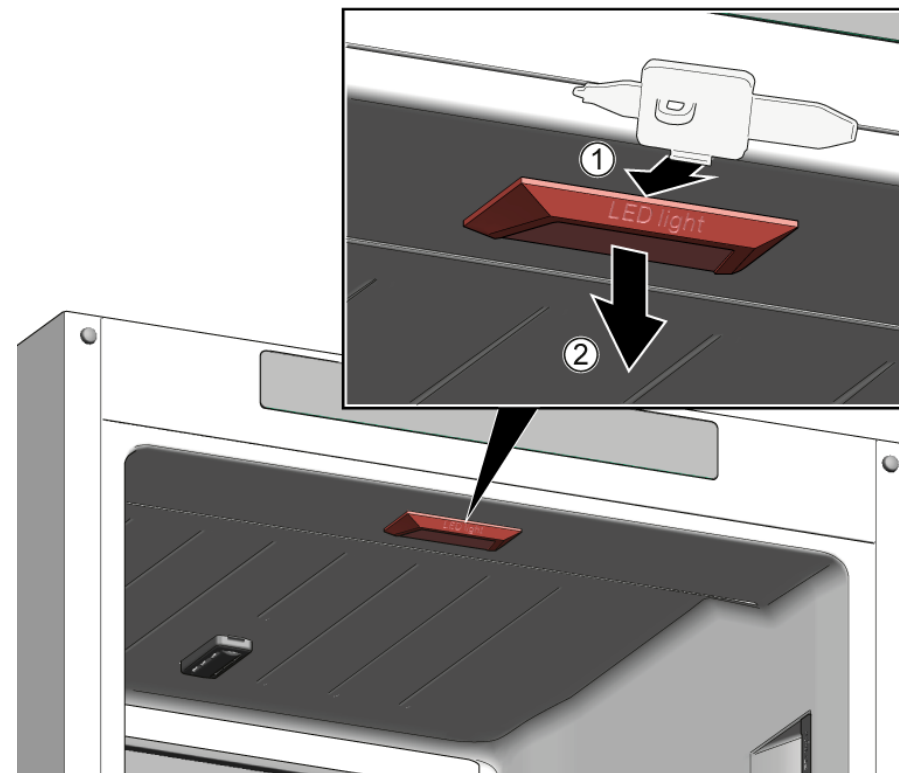

2. Lossa LED-överlampans elanslutning.
- ➡ LED-överlampan har tagits bort.

4.14.2 Montera LED-överlampa

- ▶ Montera i omvänd ordning.

4.15 Byta LED-sidolampa

Nödvändiga verktyg:

Specialverktyg

[00342180]

i Apparaten har underhållsfria LED-lampor. Sådana lampor får bara bytas av kundtjänsten eller av auktoriserade tekniker!

⚠ FARA!
Risk för elstötar på grund av strömförande delar!
Livsfara på grund av elstötar vid felaktiga reparationer

- ▶ Elektriska delar ska repareras av behörig elektriker.
- ▶ Låt utföra ett säkerhetstest efter reparationen, i enlighet med VDE 0701 eller landsspecifika regler.

⚠ FARA!
Risk för elstötar på grund av strömförande delar!
Dödsfall på grund av elstötar

- ▶ Koppla bort maskiner från elförsörjningen minst 60 sekunder innan reparationer påbörjas.

⚠ FÖRSIKTIGT!
Vassa kanter!
Skärskador

- ▶ Använd skyddshandskar.

⚠ OBS!
Risk för skador på komponenter som är känsliga för statisk elektricitet (ESD)!
Skador på komponenter

- ▶ Använd ett elektrostatiskt skyddssystem (ESD-armband) innan du rör en ESD-känslig komponent.
- ▶ Rör inte modulernas anslutningar och strömförande ledningar.
- ▶ Transportera bara ESD-känsliga komponenter i ledande material eller i originalförpackningen.
- ▶ Håll ESD-känsliga komponenter borta från material som kan laddas av statisk elektricitet (t.ex. plast).

Förutsättning:

- ✓ Apparaten är bortkopplad från strömförsörjning.
- ✓ Dörren är öppen.
- ✓ RC-tillbehör inuti apparaten har tagits bort.

4.15.1 Ta bort LED-sidolampa

1. Stick in demonteringsverktyget mellan lampdiffuser och hölje för att lossa haken (1).
2. Ta ut lampdiffusern (2).
3. Lossa efterföljande fästhakar för diffusern på samma sätt.

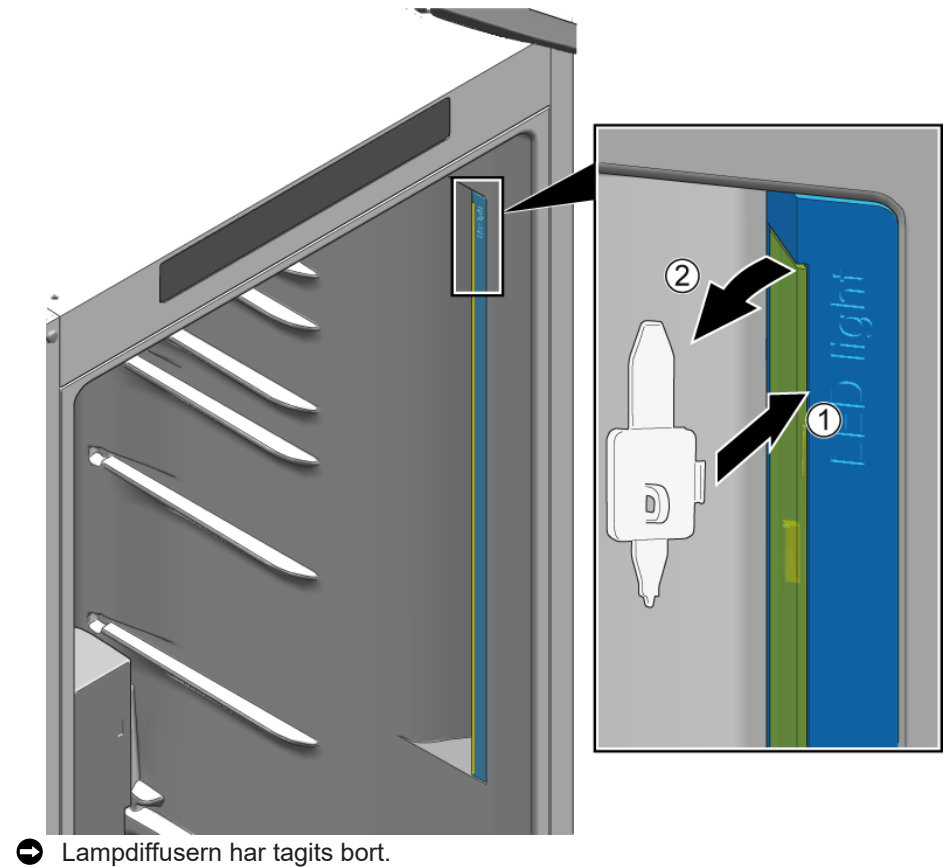

Reparation

1. Tryck på fästhaken för att lossa den (1).
2. Flytta LED-modulen ca 1 cm uppåt för att koppla bort den från eluttaget (2).
3. Ta bort LED-modulen (3).

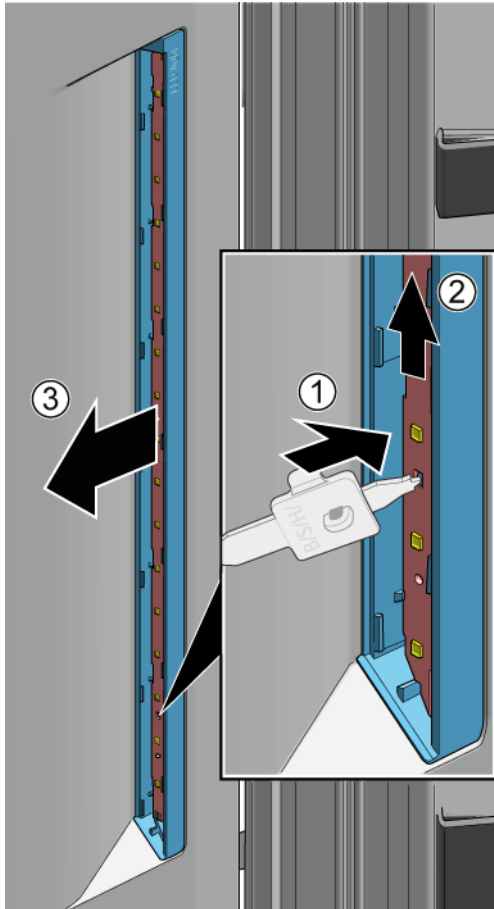

 LED-sidolampan har tagits bort.

4.15.2 Montera LED-sidolampa



På grund av att lampdiffuserns hakar lätt går sönder vid borttagningen, ingår LED-modul och lampdiffuser i reservdelen LED-sidolampa.

1. Stick in demonteringsverktyget mellan lampdiffuser och hölje för att lossa hakarna (1).
2. Ta ut lampdiffusern (2).
3. Lossa efterföljande fästhakar för diffusern på samma sätt.

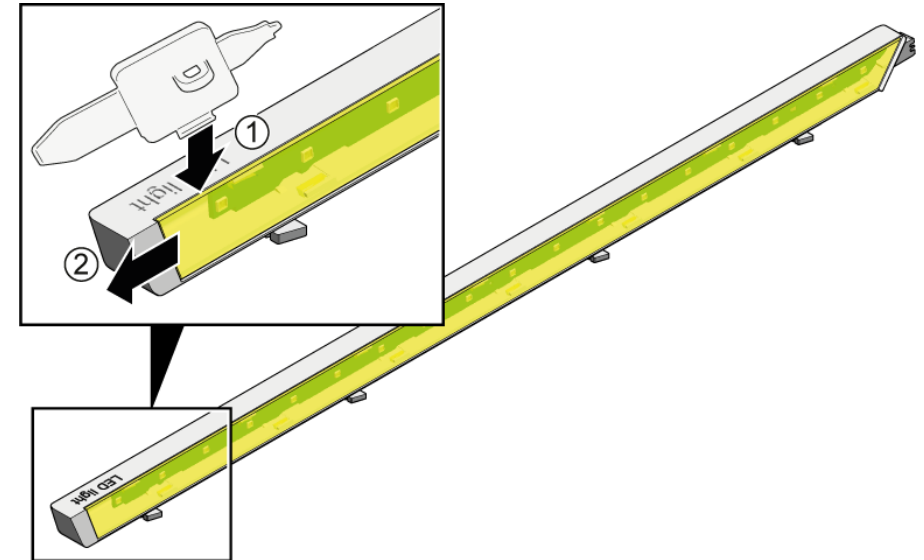

Reparation

1. Tryck på fästhaken för att lossa den (1).
2. Skjut LED-modulen uppåt och ut ur höljet.
3. De LED-modulhöljen som av säkerhetsskäl har använts för transporten av reservdelarna måste kasseras (3).

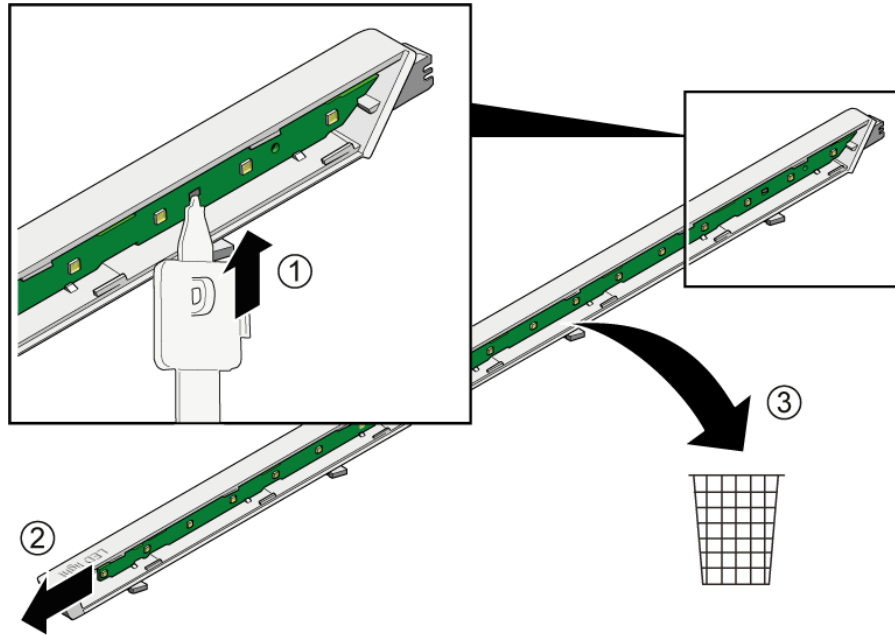

3. Montera LED-modulen och lampdiffusern i omvänd ordning jämfört med demonteringen.

4.16 Byta LED-fryslampa

Nödvändiga verktyg:

Specialverktyg [00342180]

i Apparaten har en underhållsfri LED-lampa. Sådana lampor får bara bytas av kundtjänsten eller av auktoriserade tekniker!

⚠ FARA!
Risk för elstötar på grund av strömförande delar!
Livsfara på grund av elstötar vid felaktiga reparationer

- ▶ Elektriska delar ska repareras av behörig elektriker.
- ▶ Låt utföra ett säkerhetstest efter reparationen, i enlighet med VDE 0701 eller landsspecifika regler.

⚠ FARA!
Risk för elstötar på grund av strömförande delar!
Dödsfall på grund av elstötar

- ▶ Koppla bort maskiner från elförsörjningen minst 60 sekunder innan reparationer påbörjas.

⚠ FÖRSIKTIGT!
Vassa kanter!
Skärskador

- ▶ Använd skyddshandskar.

Förutsättning:

- ✓ Apparaten är bortkopplad från strömförsörjning.
- ✓ Dörren är öppen.

4.16.1 Ta bort LED-fryslampa

- ▶ 1. För demonteringsverktyget mellan lampan och höljet vid sidan av lampan för att skapa ett mellanrum (1).
- ▶ 2. För demonteringsverktyget på andra sidan av lampans fästhake och vrid den framåt (2).
- ▶ 3. Ta bort LED-fryslampen (3).

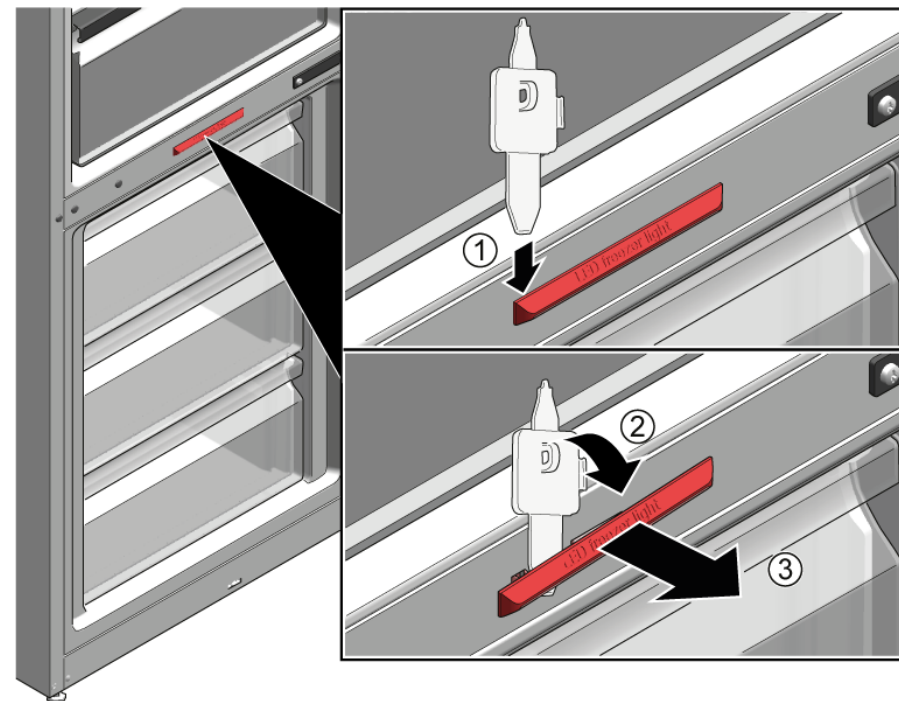

- ➡ LED-fryslampen har lossats.
- ➡ LED-fryslampen har tagits bort.

4.16.2 Montera LED-fryslampa

- ▶ Montera i omvänd ordning.

Onarım İpuçları - Soğutucu/Dondurucu kombine cihazı

i	Bu doküman hakkında	686
1.1	Önemli bilgi	686
1.1.1	Amacı.....	686
1.2	Sembollerinin açıklaması	686
1.2.1	Tehlike kademeleri	686
1.2.2	Tehlike sembolleri	686
1.2.3	İkaz bilgilerinin yapısı	687
1.2.4	Genel semboller.....	687
⚠	Güvenlik.....	688
2.1	Genel Güvenlik bilgileri	688
2.1.1	Tüm ev gereçleri	688
🔧	Ekipman ve yardım.....	689
🔧	Onarım.....	690
4.1	Kapı contasının değiştirilmesi	690
4.1.1	Kapı contasının çıkartılması	690
4.1.2	Kapı contasının takılması	690
4.2	Kapı tutamağının değiştirilmesi.....	693
4.2.1	Kapı tutamağının çıkartılması	693
4.2.2	Kapı tutamağının takılması	693
4.3	Kapının üst menteşesinin değiştirilmesi.....	694
4.3.1	Kapının üst menteşesinin çıkartılması	694
4.3.2	Kapının üst menteşesinin takılması	695
4.4	Kapının üst menteşesinin değiştirilmesi (göstergeli kapı).....	696
4.4.1	Kapının üst menteşesinin çıkartılması	697
4.4.2	Kapının üst menteşesinin takılması	698
4.5	Kapının orta menteşesinin değiştirilmesi	699
4.5.1	Kapının orta menteşesinin çıkartılması	699
4.5.2	Kapının orta menteşesinin takılması.....	700
4.6	Kapının alt menteşesinin değiştirilmesi.....	701
4.6.1	Kapının alt menteşesinin çıkartılması	701
4.6.2	Kapının alt menteşesinin takılması	701
4.7	Raf yüzeyinin değiştirilmesi	702
4.7.1	Raf yüzeyinin çıkartılması	702
4.7.2	Raf yüzeyinin takılması.....	702

4.8	Şişe rafının değiştirilmesi.....	703
4.8.1	Şişe rafının çıkartılması	703
4.8.2	Şişe rafının takılması	703
4.9	Kapı rafının değiştirilmesi	704
4.9.1	Kapı rafının çıkartılması	704
4.9.2	Kapı rafının takılması	704
4.10	Saklama kabını değiştirme.....	705
4.10.1	Saklama kabını çıkarma.....	705
4.10.2	Saklama kabını takma	705
4.11	Meyve-sebze kabının değiştirilmesi.....	706
4.11.1	Meyve-sebze kabının çıkartılması.....	706
4.11.2	Meyve-sebze kabının takılması	706
4.12	Meyve-sebze kabının üzerindeki rafı değiştirme.....	707
4.12.1	Meyve-sebze kabının üzerindeki rafı çıkarma.....	707
4.12.2	Meyve-sebze kabının üzerindeki rafı takma.....	708
4.13	Dondurulacak gıda kabının değiştirilmesi.....	709
4.13.1	Dondurulacak gıda kabının çıkartılması	709
4.13.2	Dondurulacak gıda kabının takılması	709
4.14	LED üst lambayı değiştirme	710
4.14.1	LED üst lambayı çıkarma	710
4.14.2	LED üst lambayı takma	710
4.15	LED yan lambayı değiştirme	711
4.15.1	LED yan lambayı çıkarma	711
4.15.2	LED yan lambayı takma	712
4.16	LED derin dondurucu lambasını değiştirme	714
4.16.1	LED derin dondurucu lambasını çıkarma.....	714
4.16.2	LED derin dondurucu lambasını takma	714

i Bu doküman hakkında

1.1 Önemli bilgi

1.1.1 Amacı

Bu onarım ipuçları, tüketicinin cihazları, geçerli eko-tasarım yönetmeliğine göre (03/2021 itibarıyla) kendi başına onarması için destek sunar.

İpuçları, tanımlanmış yedek parçaların nasıl değiştirilmesi gerektiğine dair bilgiler, uyarılar ve söz konusu riskleri içerir.

Sorularınız varsa, lütfen yetkili servisimizle irtibata geçiniz. Yalnızca onarım ipuçlarına gerektiği gibi uyulduğu takdirde hasarlar için sorumluluk üstleniriz.

1.2 Sembollerinin açıklaması

1.2.1 Tehlike kademeleri

Tehlike kademeleri bir sembolden ve bir sinyal kelimesinden oluşur. Sinyal kelimesi tehlikenin şiddetini ve önemini tanımlar.





Tehlike kademesi	Anlamı
 TEHLİKE	İkaz bilgisinin dikkate alınmaması ölüme veya ağır yaralanmalara sebep olur.
 UYARI	İkaz bilgisinin dikkate alınmaması ölüme veya ağır yaralanmalara sebep olabilir.
 DİKKAT	İkaz bilgisinin dikkate alınmaması hafif yaralanmalara sebep olabilir.
DİKKATI	İkaz bilgisinin dikkate alınmaması maddi hasarların oluşmasına sebep olabilir.

Tablo 1: Tehlike kademeleri



1.2.2 Tehlike sembolleri

Tehlike sembolleri, tehlike türü hakkında bilgi veren anlamlı resimsel gösterimlerdir.

Bu dokümanda aşağıdaki tehlike sembolleri kullanılmıştır:

Tehlike sembolü	Anlamı
	Genel ikaz bilgisi
	Elektrik geriliminden kaynaklanan tehlike
	Patlamadan kaynaklanan tehlike
	Kesmeden dolayı yaralanma tehlikesi
	Sıkışıp ezilmeden dolayı yaralanma tehlikesi

i Bu doküman hakkında

Tehlike sembolü	Anlamı
	Sıcak yüzeylerden kaynaklanan tehlike
	Güçlü elektromanyetik alan tehlikesi
	İyonizasyon olmayan ışınlardan kaynaklanan tehlike

Tablo 2: Tehlike sembolleri

1.2.3 İkaz bilgilerinin yapısı

Bu dokümandaki ikaz bilgilerinin standart olarak görünüşü ve yapısı aynıdır.



	⚠ TEHLİKE Tehlikenin türü ve kaynağı!! Tehlike / ikaz bilgisinin dikkate alınmamasının sonucu. ► Tehlikeye karşı korunmak için yapılacak işlem ve yasaklar.
--	--







Aşağıdaki örnekte, gerilim ileten parçalar nedeniyle oluşabilecek elektrik çarpması tehlikesi hakkında uyarıda bulunan bir ikaz bilgisi gösterilmiştir. Tehlikeyi önlemek için alınması gereken önlemler belirtilmiştir.

	⚠ TEHLİKE Gerilim ileten parçalar nedeniyle elektrik çarpması tehlikesi!! Elektrik çarpması sebebiyle ölüm ► Onarıma başlamadan önce cihazın elektrik şebeke bağlantısını en az 60 saniye süreyle sökün.
--	---

1.2.4 Genel semboller

Bu dokümanda aşağıdaki genel semboller kullanılmıştır:

Genel sembol	Anlamı
	Özel ipucu işareti (metin ve/veya grafik)
	Basit ipucu işareti (yalnızca metin)
	Video linki işareti

Genel sembol	Anlamı
	Gerekli araçlar işareti
	Ön koşulların işareti
	Koşul işareti (... olursa olur)
	Sonuç işareti
	Tuş veya düğme işareti
	Malzeme numarası işareti
	Gösterilen yazı / ekran işareti (cihaz ekranındaki)

Tablo 3: Genel semboller

2.1 Genel Güvenlik bilgileri

2.1.1 Tüm ev gereçleri

Gerilim ileten parçalar nedeniyle elektrik çarpması tehlikesi!

- Elektrikli bileşenlerde yapılan onarımlarda hatalar, elektrik çarpmasına neden olabilir!
- Cihaz çalışmalara başlamadan en az 60 saniye önce elektrik şebekesinden ayrılmalıdır.
- Onarım sonrasında VDE 0701 veya ülkeye özel düzenlemeler uyarınca bir güvenlik testi gerçekleştirilmelidir.

Keskin kenarlar nedeniyle yaralanma tehlikesi!

- Koruyucu eldiven kullanılmalıdır.

Ağır ve hareketli parçaların onarım, bakım, hata arama ve servis işlemlerinde yaratabileceği ezilme riskleri

- Koruyucu ayakkabı giyin.
- Yere düşmemesi için ağır parçaları emniyete alın.
- Hareketli parçaların arasına gövde parçaları koymayın.

Cihaz güvenliğinde / fonksiyonda tehlike!

- Yalnızca orijinal parçalar kullanılmalıdır.

Elektrostatik hassasiyeti olan bileşenlerde hasar tehlikesi (ESD)!

- Bağlantılar ve iletken yolları da dahil olmak üzere modüllere dokunmayın.

Ekipman ve yardım

Tanımlama	Detaylar	Görüntüler
Torx Bit TX20 [00340865]	6,3 mm (1/4")	
Special tool [00342180]		

4.1 Kapı contasının değiştirilmesi

Ön koşul:

- ✓ Kapı açık.

4.1.1 Kapı contasının çıkartılması

1. Kapı contasını sağ ve sol köşedeki oluklardan kurtarın.

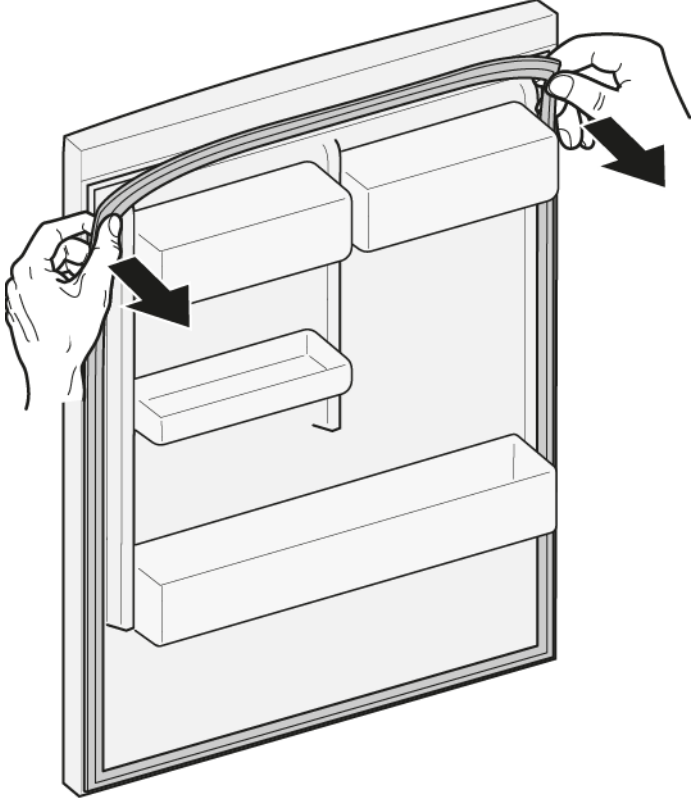

2. Kapı contasını oluktan dışarı çekin.

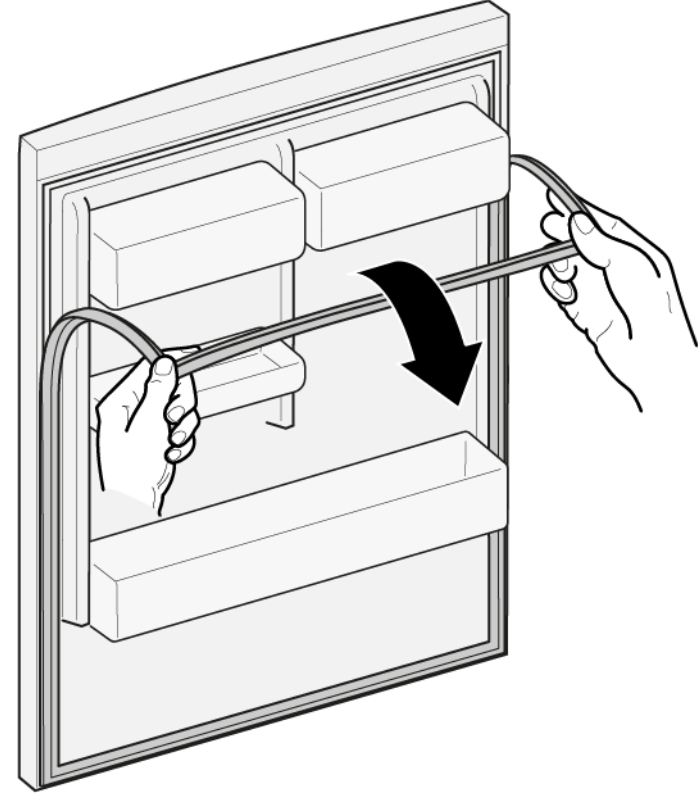

- ➡ Kapı contası çıkartılmıştır.

4.1.2 Kapı contasının takılması



Yeni kapı contasının kalınlığı, eski kapı contasının kalınlığından biraz farklı olabilir. Bu, kapının kapanma özelliğini ve uzun süreli işlevini etkilemez.

Cihazınızda ayarlanabilir menteşeler veya menteşe ekleri varsa, kapının kapanma özelliğini daha sonra optimize edebilirsiniz.

Kapı contasındaki küçük yan delikler işlevseldir (havalandırma için gereklidir). Bunlar üretim hatası değildir.

1. Conta için oluğu hasar bakımından kontrol edin.

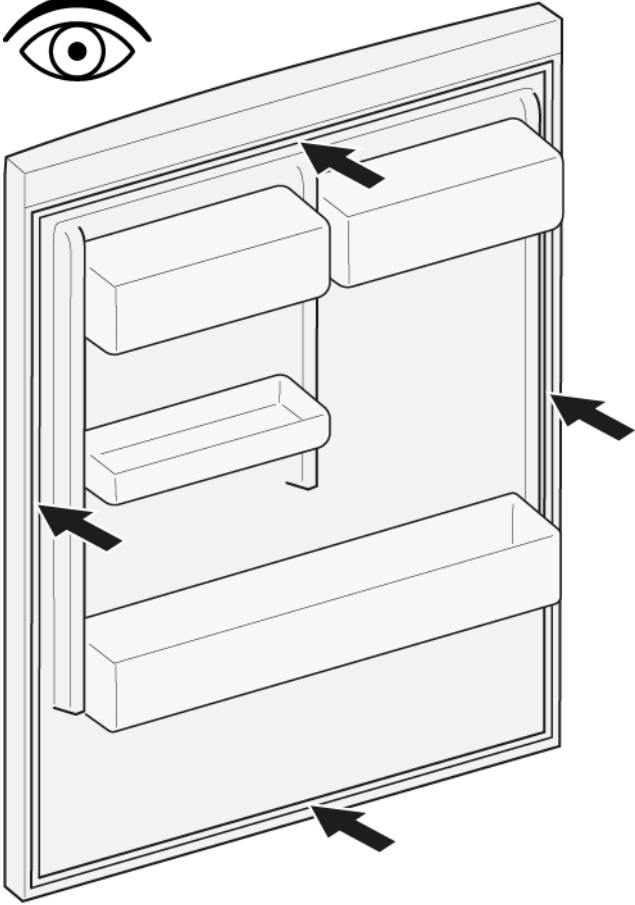

4. Contanın köşelerini üstten ve alttan oluğa itin.

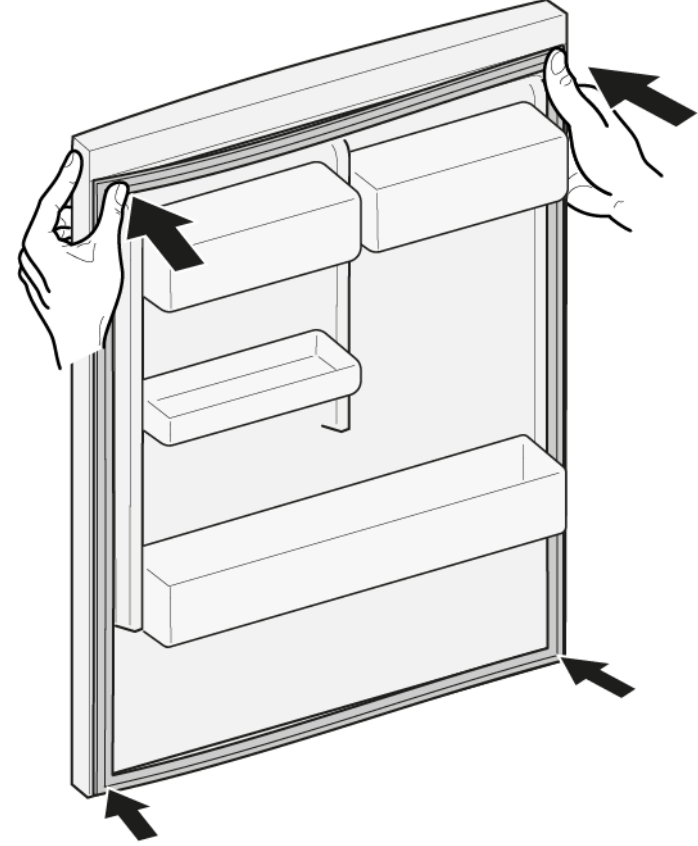



2.  Conta için oluk hasarlı ise,
- Müşteri hizmetleriyle irtibata geçin.

3.  Kapı contasında hafif deformasyon normaldir ve contanın işlevini etkilemez. Kapı contasını cihaza yerleştirmeden önce contanın düzleştirilmesi önerilir.

Kapı contasını bir saç kurutma makinesi veya sıcak suyla ısıtın ve manuel olarak şekillendirin.

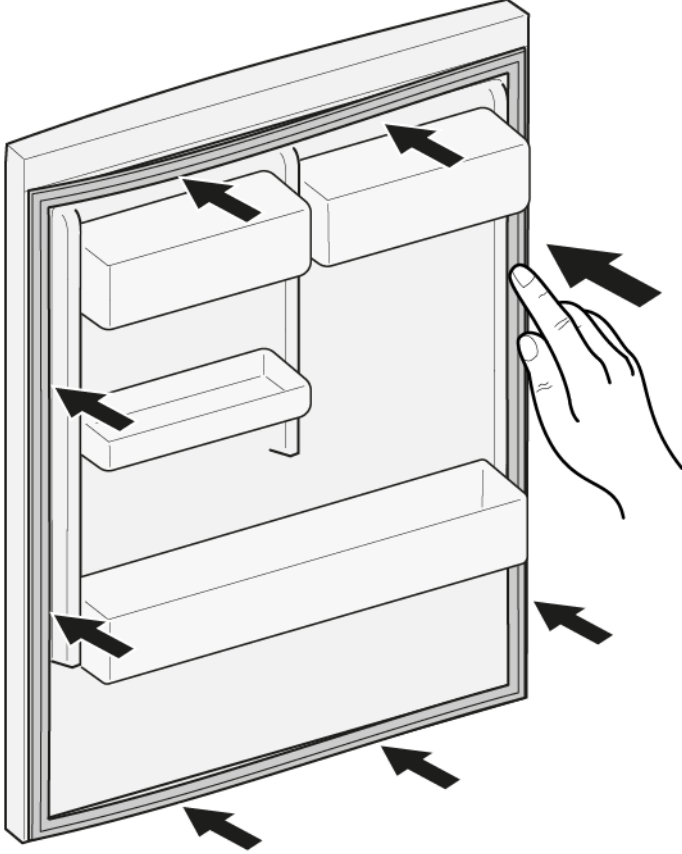

5. Contanın tamamını adım adım oluğun içine bastırın.





 Kapı contası takılmıştır.

4.2 Kapı tutamağının değiştirilmesi

Özel yardımcı ekipman:

-  Torx Bit TX20 6,3 mm (1/4") [00340865]
-  Düz tornavida Bıçak 10 mm x 1,6 mm x 200 mm

Ön koşul:

-  Cihazın fişi çekilir.
-  Kapı açık.

4.2.1 Kapı tutamağının çıkartılması

- ▶ 1. İki vidalı kapağı çıkartın (1).
- ▶ 2. Vidaları sökün (2).
- ▶ 3. Kapı tutamağını çıkartın (3).

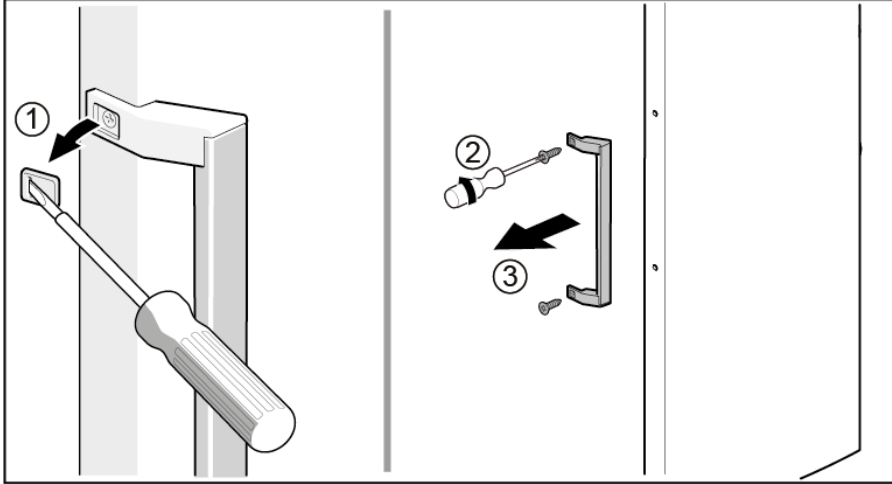

 Kapı tutamağı çıkartılmıştır.



İkinci kapının tutamağı da aynı şekilde çıkartılabilir.

4.2.2 Kapı tutamağının takılması

- ▶ Ters sıra ile monte edin.

4.3 Kapının üst menteşesinin değiştirilmesi

Özel yardımcı ekipman:

Torx Bit TX20

6,3 mm (1/4")

[00340865]



UYARI

Ağır, büyük cihazlar!

Sırt ve kas yaralanmaları

- ▶ Cihaz kapısını çıkarma işlemi sadece eğitimli uzmanlar tarafından gerçekleştirilmelidir.
- ▶ Cihazı hareket ettirmek için iki kişi gereklidir.
- ▶ Sadece uygun aletler ve ekipmanlar kullanın.



DİKKAT

Keskin köşeler!

Kesik yaralanmaları

- ▶ Koruyucu eldiven kullanılmalıdır.



UYARI

Eğilmiş cihazların kayması!

Kemik kırılmaları / çarpma sonucu yaralanmalar

- ▶ Cihazları kaymaya karşı emniyete alın.



DİKKAT

Vidaların gevşetilmesi nedeniyle parçaların düşme tehlikesi!

Düşen parçalar nedeniyle yaralanma.

- ▶ Bileşenleri düşmeye karşı emniyete alın.



DİKKAT!

Vidaların gevşetilmesi nedeniyle parçaların düşme tehlikesi!

Cihazın diğer parçalarında veya müşterinin evinde (örn. zemin) hasarlar.

- ▶ Bileşenleri düşmeye karşı emniyete alın.

Ön koşul:

- ✓ Cihazın fişi çekilir.
- ✓ Cihazın iç donanımları çıkartılmıştır.

4.3.1 Kapının üst menteşesinin çıkartılması

1. Destek parçasını taban bölümünün altına kaydırın.

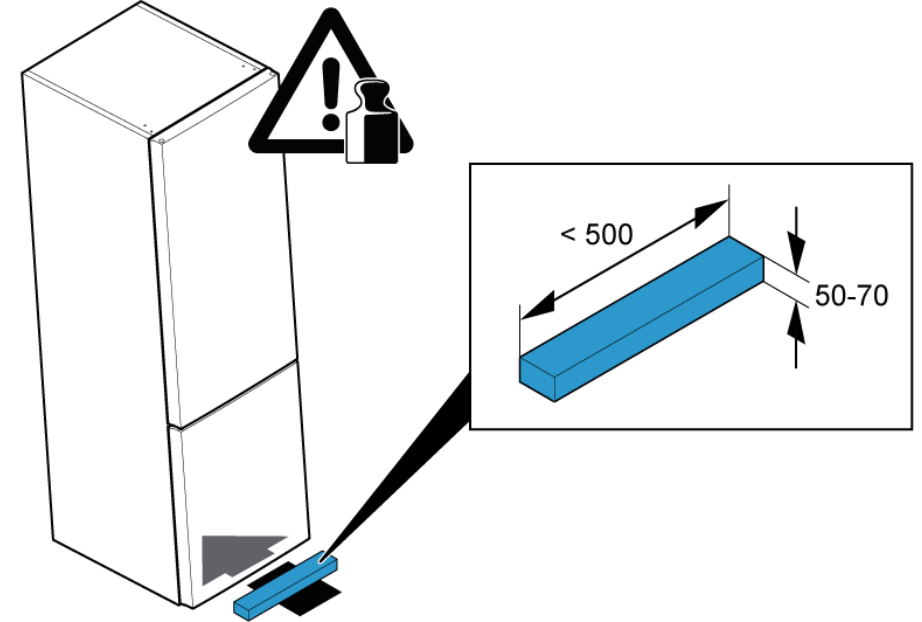

2. 1. Üst menteşe kapağını çıkarın (1).
2. İki vidayı sökün (2).
3. Üst menteşeyi çıkarın (3).

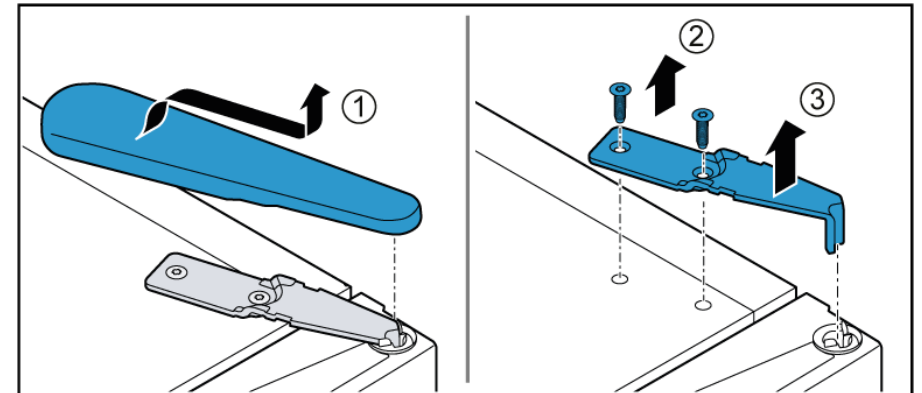

3. Üst kapağı çıkarın.

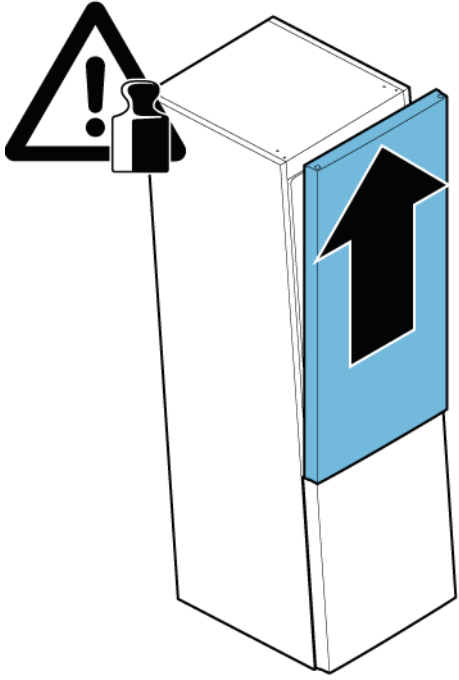

 Üst menteşe çıkartılmıştır.

4.3.2 Kapının üst menteşesinin takılması

► Ters sıra ile monte edin.

4.4 Kapının üst menteşesinin değiştirilmesi (göstergeli kapı)

Özel yardımcı ekipman:

 Torx Bit TX20

6,3 mm (1/4")

[00340865]

	UYARI Ağır, büyük cihazlar! Sırt ve kas yaralanmaları <ul style="list-style-type: none">▶ Cihaz kapısını çıkarma işlemi sadece eğitimli uzmanlar tarafından gerçekleştirilmelidir.▶ Cihazı hareket ettirmek için iki kişi gereklidir.▶ Sadece uygun aletler ve ekipmanlar kullanın.
--	---

	DİKKAT Keskin köşeler! Kesik yaralanmaları <ul style="list-style-type: none">▶ Koruyucu eldiven kullanılmalıdır.
--	--

	UYARI Eğilmiş cihazların kayması! Kemik kırılmaları / çarpma sonucu yaralanmalar <ul style="list-style-type: none">▶ Cihazları kaymaya karşı emniyete alın.
--	---

	DİKKAT Vidaların gevşetilmesi nedeniyle parçaların düşme tehlikesi! Düşen parçalar nedeniyle yaralanma. <ul style="list-style-type: none">▶ Bileşenleri düşmeye karşı emniyete alın.
---	--

	DİKKAT! Vidaların gevşetilmesi nedeniyle parçaların düşme tehlikesi! Cihazın diğer parçalarında veya müşterinin evinde (örn. zemin) hasarlar. <ul style="list-style-type: none">▶ Bileşenleri düşmeye karşı emniyete alın.
--	--

	TEHLİKE Gerilim ileten parçalar nedeniyle elektrik çarpması tehlikesi!! Onarımın düzgün yapılmaması nedeniyle elektrik çarpması sonucu hayati tehlike <ul style="list-style-type: none">▶ Elektrikli parçaların onarımı kalifiye bir elektrik uzmanı tarafından gerçekleştirilmelidir.▶ Onarım sonrasında VDE 0701 veya ülkeye özel düzenlemeler uyarınca bir güvenlik testi gerçekleştirilmelidir.
---	--

	TEHLİKE Gerilim ileten parçalar nedeniyle elektrik çarpması tehlikesi!! Elektrik çarpması sebebiyle ölüm <ul style="list-style-type: none">▶ Onarıma başlamadan önce cihazın elektrik şebeke bağlantısını en az 60 saniye süreyle sökün.
---	--

Ön kontrol:

- Cihazın fişi çekilir.
- Cihazın iç donanımları çıkartılmıştır.

4.4.1 Kapının üst menteşesinin çıkartılması

1. Destek parçasını taban bölümünün altına kaydırın.

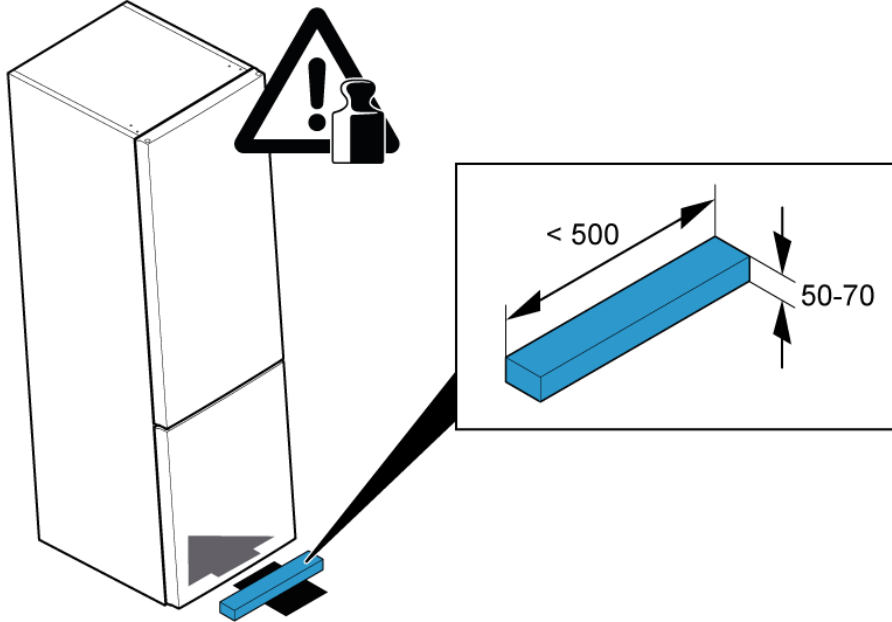

2. 1. Üst menteşe kapağını çıkarın (1).
2. Elektrik bağlantısını kesin (2).
3. Topraklama bağlantısı vidasını sökün (3).

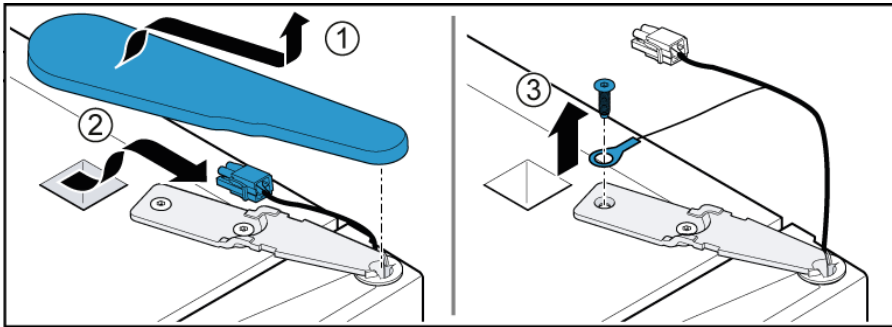

3. 1. Vidayı sökün (1).
2. Üst menteşeyi çıkarın (2).

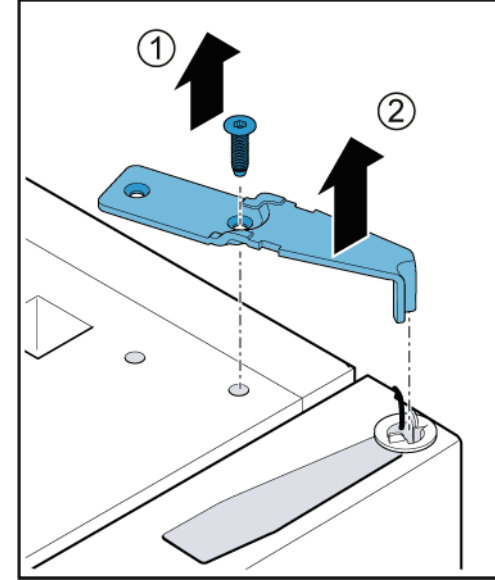

4. Üst kapağı çıkarın.

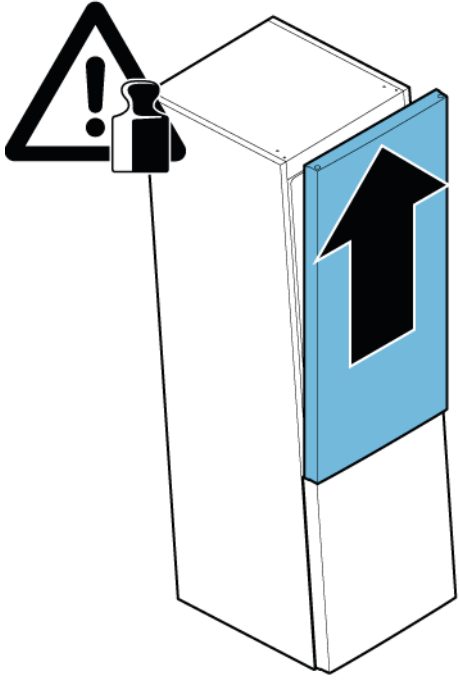

 Üst menteşe çıkartılmıştır.

4.4.2 Kapının üst menteşesinin takılması

► Ters sıra ile monte edin.

4.5 Kapının orta menteşesinin değiştirilmesi

Özel yardımcı ekipman:

Torx Bit TX20

6,3 mm (1/4")

[00340865]



UYARI

Ağır, büyük cihazlar!

Sırt ve kas yaralanmaları

- ▶ Cihaz kapısını çıkarma işlemi sadece eğitimli uzmanlar tarafından gerçekleştirilmelidir.
- ▶ Cihazı hareket ettirmek için iki kişi gereklidir.
- ▶ Sadece uygun aletler ve ekipmanlar kullanın.



DİKKAT

Keskin köşeler!

Kesik yaralanmaları

- ▶ Koruyucu eldiven kullanılmalıdır.



UYARI

Eğilmiş cihazların kayması!

Kemik kırılmaları / çarpma sonucu yaralanmalar

- ▶ Cihazları kaymaya karşı emniyete alın.



DİKKAT

Vidaların gevşetilmesi nedeniyle parçaların düşme tehlikesi!

Düşen parçalar nedeniyle yaralanma.

- ▶ Bileşenleri düşmeye karşı emniyete alın.



DİKKAT!

Vidaların gevşetilmesi nedeniyle parçaların düşme tehlikesi!

Cihazın diğer parçalarında veya müşterinin evinde (örn. zemin) hasarlar.

- ▶ Bileşenleri düşmeye karşı emniyete alın.

Ön koşul:

- ✓ Cihazın fişi çekilir.
- ✓ Cihazın iç donanımları çıkartılmıştır.
- ✓ Kapının üst menteşesi çıkartılmıştır.
- ✓ Üst kapı çıkartılmıştır.

4.5.1 Kapının orta menteşesinin çıkartılması

1. İki vidayı sökün (1).
2. Orta menteşeyi çıkarın (2).

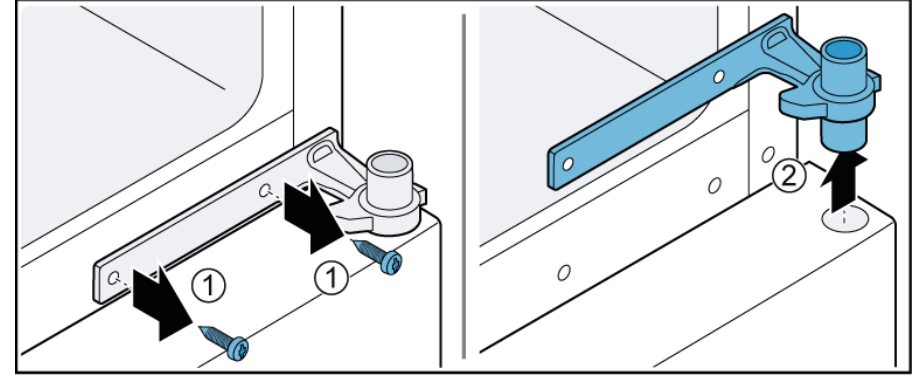

2. Alt kapıyı sökün.

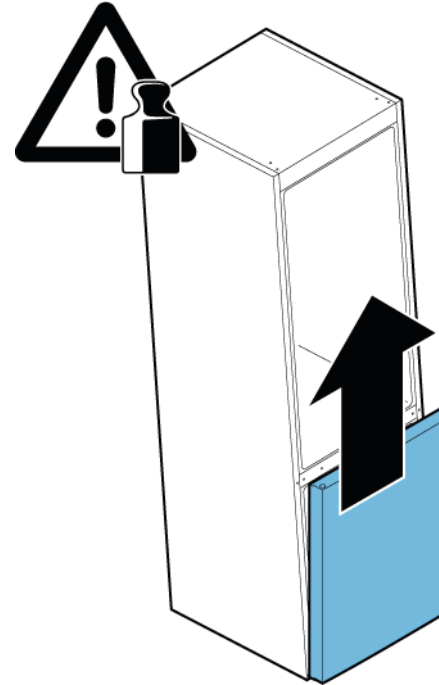

- ➡ Orta menteşe çıkartılmıştır.

4.5.2 Kapının orta menteşesinin takılması

- ▶ Ters sıra ile monte edin.

4.6 Kapının alt menteşesinin değiştirilmesi

Özel yardımcı ekipman:

Torx Bit TX20

6,3 mm (1/4")

[00340865]

	<p>UYARI</p> <p>Ağır, büyük cihazlar! Sırt ve kas yaralanmaları</p> <ul style="list-style-type: none">▶ Cihaz kapısını çıkarma işlemi sadece eğitimli uzmanlar tarafından gerçekleştirilmelidir.▶ Cihazı hareket ettirmek için iki kişi gereklidir.▶ Sadece uygun aletler ve ekipmanlar kullanın.
--	---

	<p>DİKKAT</p> <p>Keskin köşeler! Kesik yaralanmaları</p> <ul style="list-style-type: none">▶ Koruyucu eldiven kullanılmalıdır.
--	--

	<p>UYARI</p> <p>Eğilmiş cihazların kayması! Kemik kırılmaları / çarpma sonucu yaralanmalar</p> <ul style="list-style-type: none">▶ Cihazları kaymaya karşı emniyete alın.
--	---

	<p>DİKKAT</p> <p>Vidaların gevşetilmesi nedeniyle parçaların düşme tehlikesi! Düşen parçalar nedeniyle yaralanma.</p> <ul style="list-style-type: none">▶ Bileşenleri düşmeye karşı emniyete alın.
---	--

	<p>DİKKAT!</p> <p>Vidaların gevşetilmesi nedeniyle parçaların düşme tehlikesi! Cihazın diğer parçalarında veya müşterinin evinde (örn. zemin) hasarlar.</p> <ul style="list-style-type: none">▶ Bileşenleri düşmeye karşı emniyete alın.
--	--

Ön koşul:

- ✓ Cihazın fişi çekilir.
- ✓ Cihazın iç donanımları çıkartılmıştır.
- ✓ Üst menteşe çıkarılır.
- ✓ Orta menteşe çıkartılmıştır.

4.6.1 Kapının alt menteşesinin çıkartılması

- ▶ 1. İki vidayı sökün (1).
- ▶ 2. Alt menteşeyi çıkarın (2).

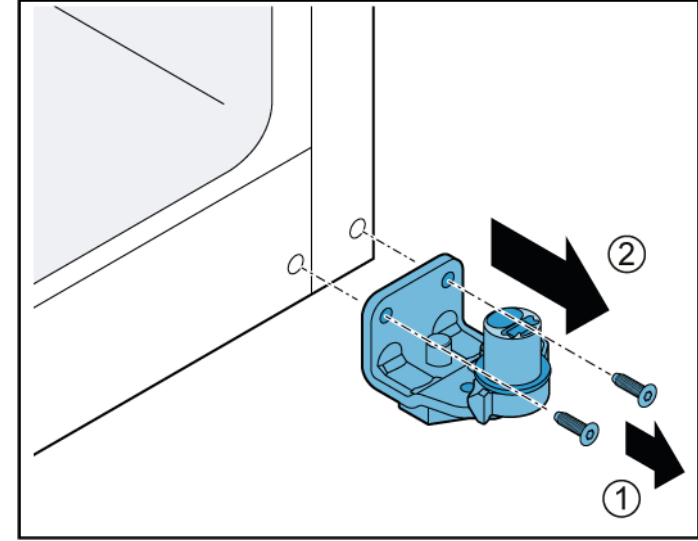

➡ Kapının alt menteşesi çıkartılmıştır.

4.6.2 Kapının alt menteşesinin takılması

- ▶ Ters sıra ile monte edin.

4.7 Raf yüzeyinin değiştirilmesi

Ön koşul:

- ✔ Kapı açık.

4.7.1 Raf yüzeyinin çıkartılması

- ▶ 1. Rafı arka kısımdan kaldırın (1).
- ▶ 2. Rafı çıkarın (2).

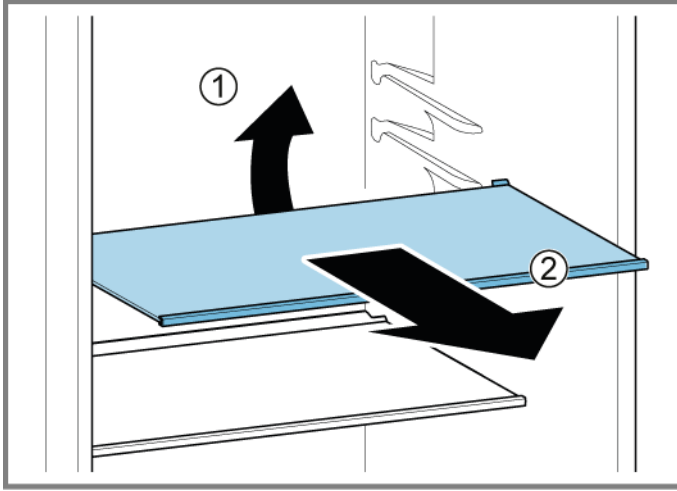

➡ Raf çıkartılmıştır.

4.7.2 Raf yüzeyinin takılması

- ▶ Ters sıra ile monte edin.

4.8 Şiše rafının değiştirilmesi

Ön koşul:

- ✔ Kapı açık.

4.8.1 Şiše rafının çıkartılması

- ▶ Şiše rafını dışarı çekin.

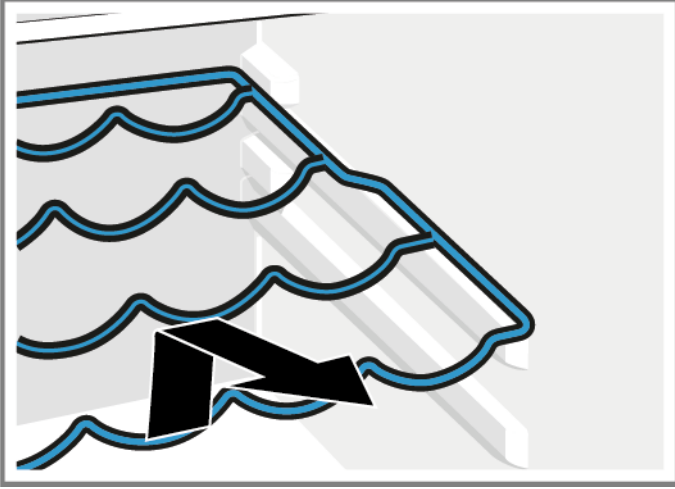

- ➡ Şiše rafı çıkartılmıştır.

4.8.2 Şiše rafının takılması

- ▶ Ters sıra ile monte edin.

4.9 Kapı rafının değiştirilmesi

Ön koşul:

- ✔ Kapı açık.

4.9.1 Kapı rafının çıkartılması

- ▶ Kapı rafını yukarıya doğru kaldırın.

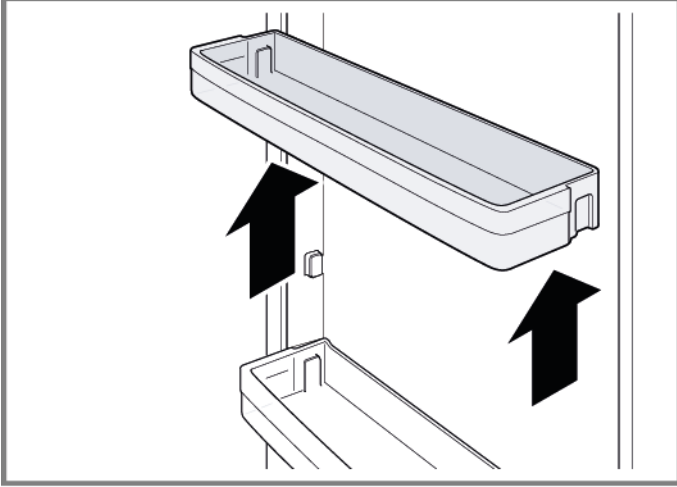

➡ Kapı rafı çıkartılmıştır.

4.9.2 Kapı rafının takılması

- ▶ Ters sıra ile monte edin.

4.10 Saklama kabını deęiřtirme

Ön koşul:

- ✓ Kapı açık.

4.10.1 Saklama kabını çıkarma

1. Saklama kabını gidebildiđi yere kadar dıřarı çekin.
2. 1. Saklama kabını ön kısımdan kaldırın (1).
2. Kabı çıkarın (2).

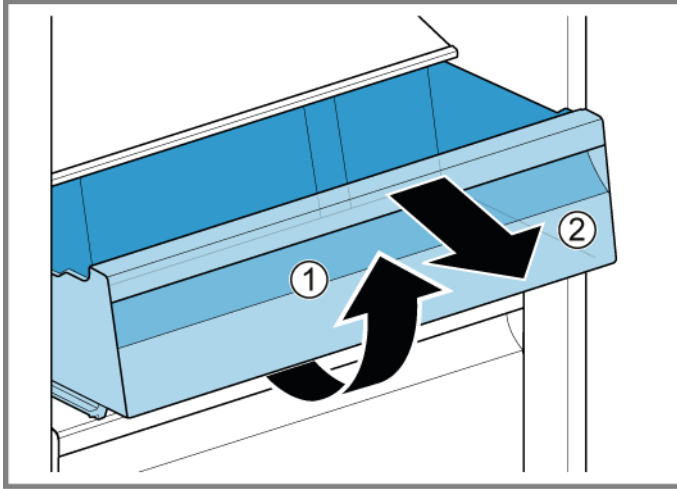

- ➔ Saklama kabı çıkartılmıştır.

4.10.2 Saklama kabını takma

- ▶ Ters sıra ile monte edin.

4.11 Meyve-sebze kabının deęiřtirilmesi

Ön koęul:

- ✓ Kapı açık.

4.11.1 Meyve-sebze kabının ıkartılması

1. Meyve-sebze kabını gidebildięi yere kadar dıřarı ekin.
2. 1. Meyve-sebze kabını ön kısımdan kaldırın (1).
2. Kabı ıkarın (2).

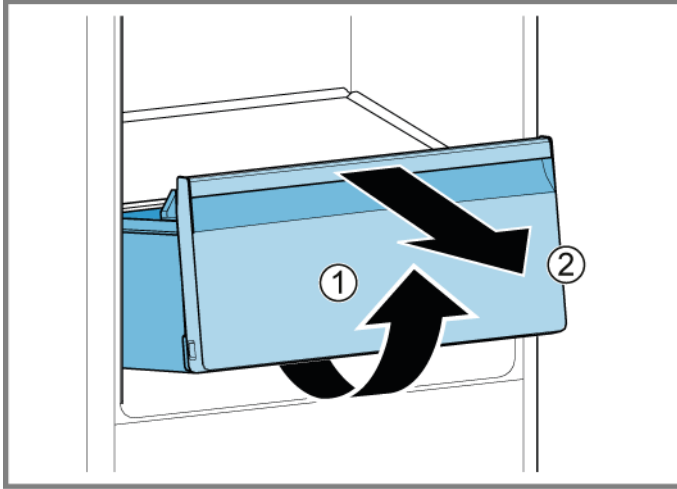

- ➔ Meyve-sebze kabı ıkartılmıřtır.

4.11.2 Meyve-sebze kabının takılması

- ▶ Ters sıra ile monte edin.

4.12 Meyve-sebze kabının üzerindeki rafı deęiřtirme

Ön koşul:

- ✓ Kapı açık.
- ✓ [Meyve-sebze kabı çıkartılmıştır.→706](#)

4.12.1 Meyve-sebze kabının üzerindeki rafı çıkarma

1. Sızdırmazlık çerçevesini yukarı ve dışarı doğru itin.

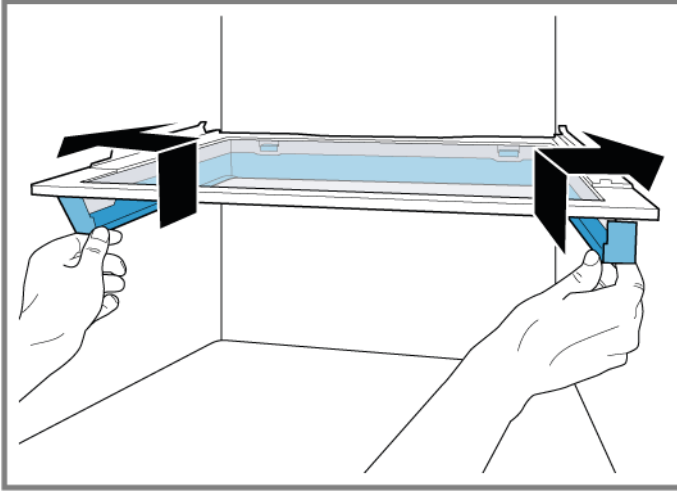

➡ Yan kancalar çözülür.

2. Sızdırmazlık çerçevesini yukarı kaldırın ve geriye doğru kaydırın.

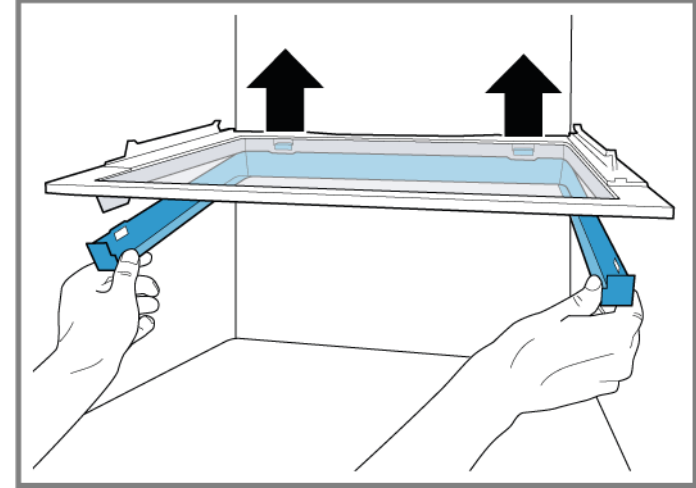

➡ Arka kancalar çözülmüřtür.

3. Sızdırmazlık çerçevesini çıkarın.
4. Meyve-sebze kabının üzerindeki rafı kaldırın ve yana doğru çevirin.

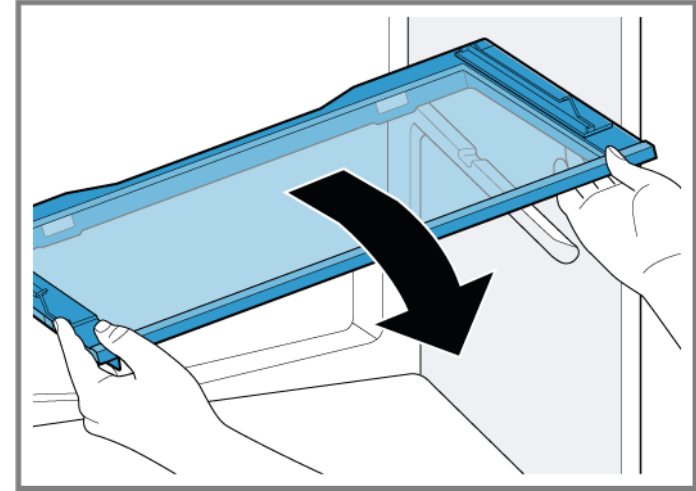

➡ Meyve-sebze kabının üstündeki raf çıkartılmıştır.

4.12.2 Meyve-sebze kabının üzerindeki rafı takma

- ▶ Ters sıra ile monte edin.

4.13 Dondurulacak gıda kabının deęiřtirilmesi

Ön koşul:

- ✓ Kapı açık.

4.13.1 Dondurulacak gıda kabının çıkartılması

- ▶ 1. Dondurulacak gıda kabını tamamen dışarı çekin (1).
- ▶ 2. Gıda kabını çıkartın (2).

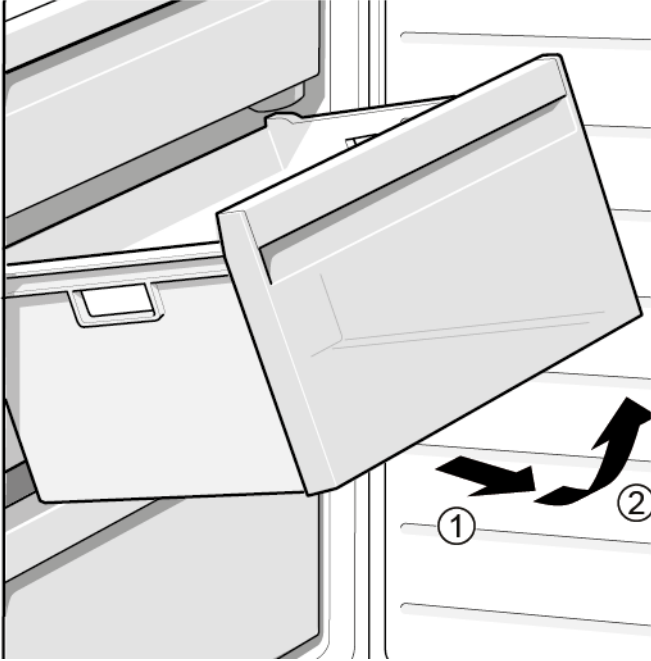

➡ Dondurulacak gıda kabı çıkartılmıştır.

4.13.2 Dondurulacak gıda kabının takılması

- ▶ Ters sıra ile monte edin.

4.14 LED üst lambayı değiştirme

Özel yardımcı ekipman:

Special tool

[00342180]

i Cihazınızda bakım gerektirmeyen bir LED ışık bulunmaktadır.
Bu ışıklar sadece müşteri hizmetleri veya yetkili teknisyenler tarafından onarılabilir!

⚠ TEHLİKE
Gerilim ileten parçalar nedeniyle elektrik çarpması tehlikesi!!
Onarımın düzgün yapılmaması nedeniyle elektrik çarpması sonucu hayati tehlike

- ▶ Elektrikli parçaların onarımı kalifiye bir elektrik uzmanı tarafından gerçekleştirilmelidir.
- ▶ Onarım sonrasında VDE 0701 veya ülkeye özel düzenlemeler uyarınca bir güvenlik testi gerçekleştirilmelidir.

⚠ TEHLİKE
Gerilim ileten parçalar nedeniyle elektrik çarpması tehlikesi!!
Elektrik çarpması sebebiyle ölüm

- ▶ Onarıma başlamadan önce cihazın elektrik şebeke bağlantısını en az 60 saniye süreyle sökün.

⚠ DİKKAT
Keskin köşeler!
Kesik yaralanmaları

- ▶ Koruyucu eldiven kullanılmalıdır.

Ön koşul:

- ✓ Cihazın fişi çekilir.
- ✓ Kapı açık.

4.14.1 LED üst lambayı çıkarma

1. Lamba kancalarını sökmek için sökme aletini LED üst lamba ile soğutucu bölme astarı arasına kaydırın (1).
2. LED üst lambayı çıkarın (2).

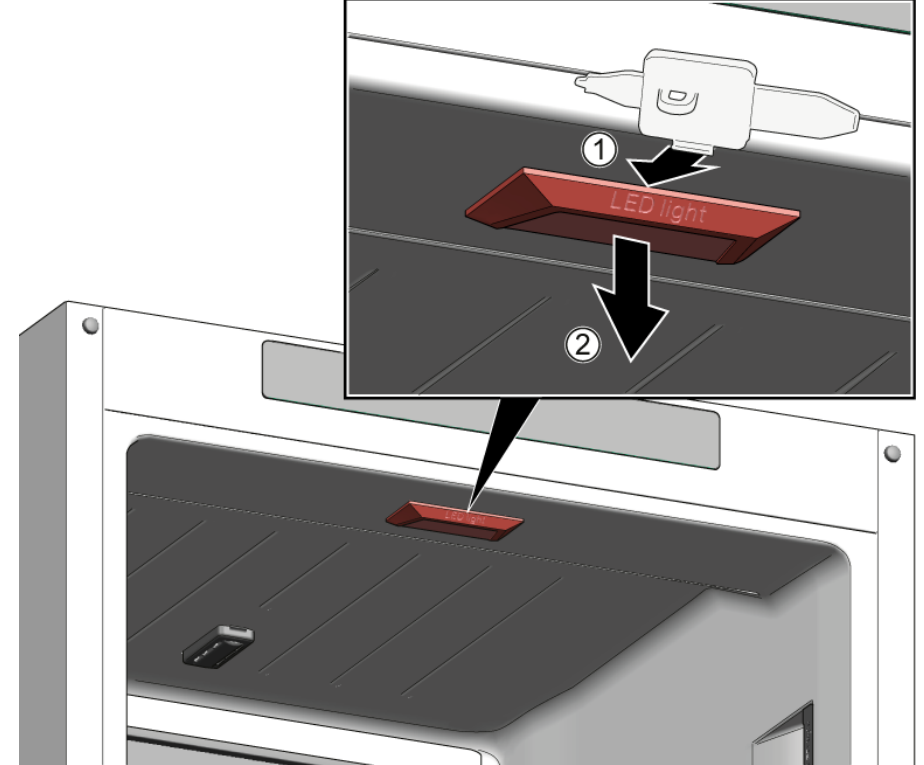

2. LED üst lambanın elektrik bağlantısını ayırın.
- ➡ LED üst lamba çıkartılmıştır.

4.14.2 LED üst lambayı takma

- ▶ Ters sıra ile monte edin.

4.15 LED yan lambayı değiştirme

Özel yardımcı ekipman:

Special tool

[00342180]

 Cihazınızda bakım gerektirmeyen bir LED lamba bulunmaktadır. Bu lambalar sadece müşteri hizmetleri veya yetkili teknisyenler tarafından onarılabilir!

 **TEHLİKE**
Gerilim ileten parçalar nedeniyle elektrik çarpması tehlikesi!!
Onarımın düzgün yapılmaması nedeniyle elektrik çarpması sonucu hayati tehlike

- ▶ Elektrikli parçaların onarımı kalifiye bir elektrik uzmanı tarafından gerçekleştirilmelidir.
- ▶ Onarım sonrasında VDE 0701 veya ülkeye özel düzenlemeler uyarınca bir güvenlik testi gerçekleştirilmelidir.

 **TEHLİKE**
Gerilim ileten parçalar nedeniyle elektrik çarpması tehlikesi!!
Elektrik çarpması sebebiyle ölüm

- ▶ Onarıma başlamadan önce cihazın elektrik şebeke bağlantısını en az 60 saniye süreyle sökün.

 **DİKKAT**
Keskin köşeler!
Kesik yaralanmaları

- ▶ Koruyucu eldiven kullanılmalıdır.

 **DİKKAT!**
Elektrostatik hassasiyeti olan bileşenlerde (ESD'ler) hasar tehlikesi!
Bileşenlerin hasar görmesi

- ▶ Elektrostatik hassasiyeti olan bileşenlere dokunmadan önce bir elektrostatik koruma sistemi (topraklamalı bileklik) takılmalıdır.
- ▶ Modülün bağlantılarına ve iletken yollarına temas edilmemelidir.
- ▶ Elektrostatik hassasiyeti olan bileşenler yalnızca iletken malzemeler içinde veya orijinal ambalajında taşınmalıdır.
- ▶ Elektrostatik hassasiyeti olan bileşenler, elektrostatik olarak yüklenebilecek malzemelerden (örneğin plastiklerden) uzak tutulmalıdır.

Ön kopul:

- ✓ Cihazın fişi çekilir.
- ✓ Kapı açık.
- ✓ RC iç donanımlar çıkartılmıştır.

4.15.1 LED yan lambayı çıkarma

1. Sökme aletini lamba difüzörü ile gövde arasına kaydırarak kancayı serbest bırakın (1).
2. Lamba difüzörünü çıkarın (2).
3. Ardından gelen difüzör sabitleme kancalarını da aynı yolu izleyerek serbest bırakın.

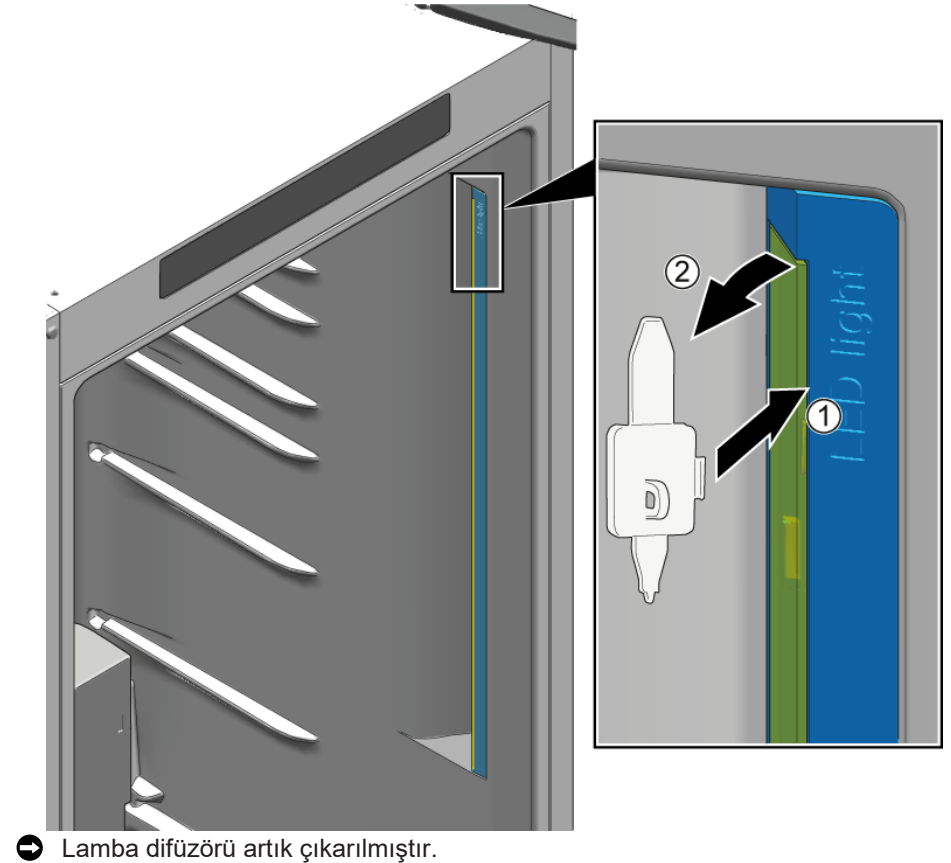

1. Sabitleme kancasını bastırarak serbest bırakın (1).
2. LED modülünü yaklaşık 1 cm yukarı hareket ettirerek çıkarın ve elektrik priziyle arasındaki bağlantıyı kesin (2).
3. LED modülünü çıkarın (3).

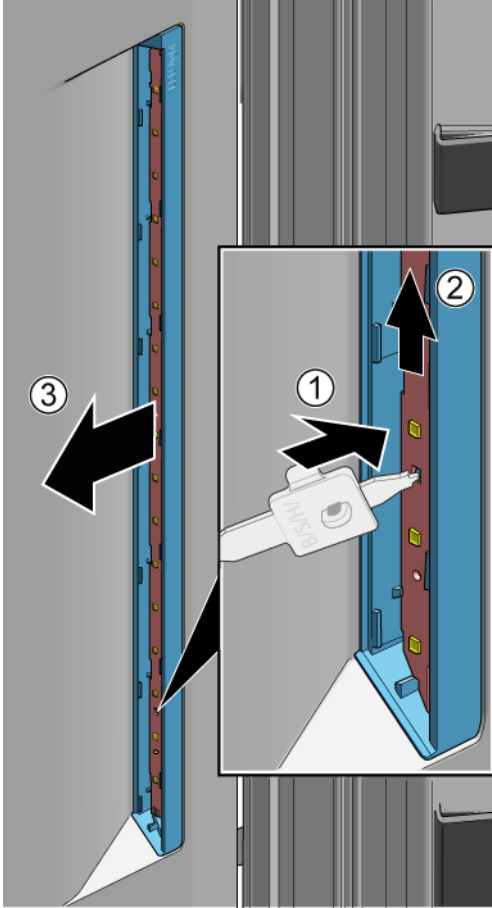

LED yan lamba artık çıkarılmıştır.

4.15.2 LED yan lambayı takma



Lamba difüzör kancalarının sökme işlemi sırasında kolay kırılabilmesi nedeniyle yedek parça LED yan lamba, LED modülünü ve lamba difüzörünü içeren bir set halindedir.

1. Sökme aletini lamba difüzörü ile gövde arasına kaydırarak kancayı serbest bırakın (1).
2. Lamba difüzörünü çıkarın (2).
3. Ardından gelen difüzör sabitleme kancalarını da aynı yolu izleyerek serbest bırakın.

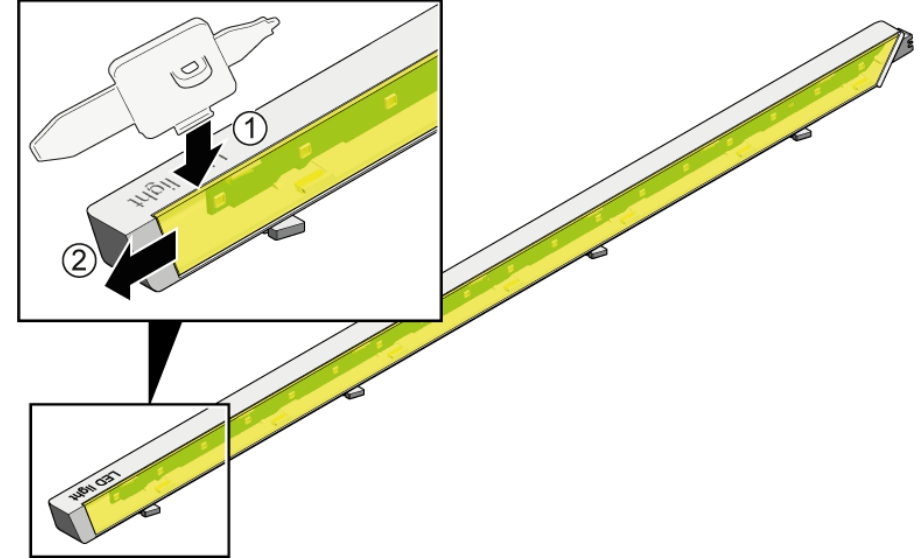

2. 1. Sabitleme kancasını bastırarak serbest bırakın (1).
2. LED modülünü gövdeden çıkana kadar yukarı kaydırın.
3. Yedek parça nakliyesinde kullanılan LED modülü gövdesini güvenlik nedenleriyle ıskartaya çıkarın (3).

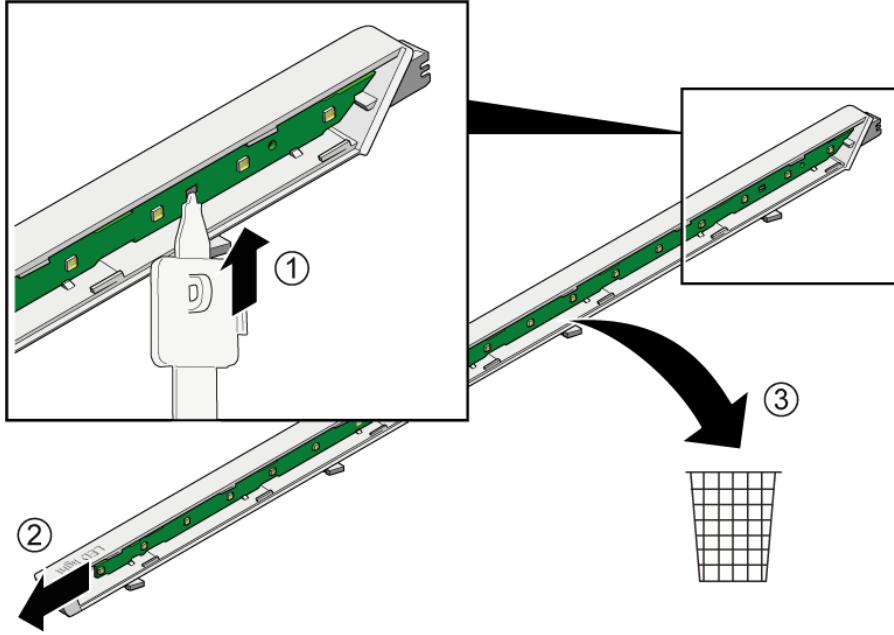

3. LED modülünü ve lamba difüzörünü sökme işleminin tersi sırayla monte edin.

4.16 LED derin dondurucu lambasını deęiřtirme

Özel yardımcı ekipman:

Special tool

[00342180]

i Cihazınızda bakım gerektirmeyen bir LED ışık bulunmaktadır. Bu ışıklar sadece müşteri hizmetleri veya yetkili teknisyenler tarafından onarılabilir!

! TEHLİKE
Gerilim ileten parçalar nedeniyle elektrik çarpması tehlikesi!!
Onarımın düzgün yapılmaması nedeniyle elektrik çarpması sonucu hayati tehlike

- ▶ Elektrikli parçaların onarımı kalifiye bir elektrik uzmanı tarafından gerçekleştirilmelidir.
- ▶ Onarım sonrasında VDE 0701 veya ülkeye özel düzenlemeler uyarınca bir güvenlik testi gerçekleştirilmelidir.

! TEHLİKE
Gerilim ileten parçalar nedeniyle elektrik çarpması tehlikesi!!
Elektrik çarpması sebebiyle ölüm

- ▶ Onarıma başlamadan önce cihazın elektrik şebeke bağlantısını en az 60 saniye süreyle sökün.

! DİKKAT
Keskin köşeler!
Kesik yaralanmaları

- ▶ Koruyucu eldiven kullanılmalıdır.

Ön koşul:

- ✓ Cihazın fiři çekilir.
- ✓ Kapı açık.

4.16.1 LED derin dondurucu lambasını çıkarma

- ▶ 1. Boşluk oluşturmak için sökme aletini lamba ve lambanın yanındaki muhafaza arasına kaydırın (1).
- ▶ 2. Sökme aletini lamba sabitleme kancasının diğer tarafına kaydırın ve ileri doğru döndürün (2).
- ▶ 3. LED derin dondurucu lambasını (3) çıkarın.

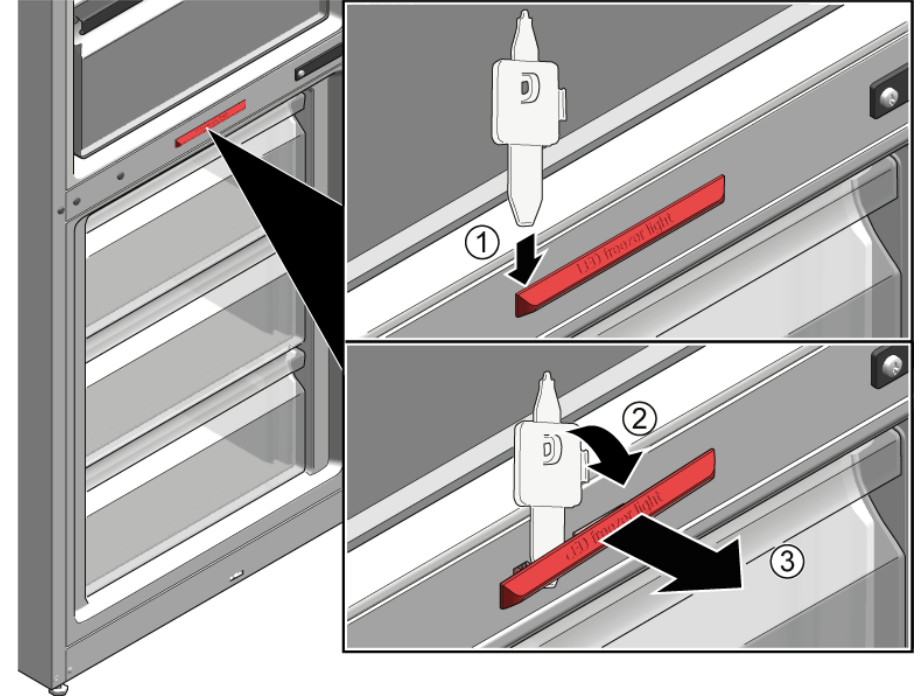

- ➡ LED derin dondurucu lambası bağlı deęil.
- ➡ LED derin dondurucu lambası çıkartılmıştır.

4.16.2 LED derin dondurucu lambasını takma

- ▶ Ters sıra ile monte edin.