

Installation guide for Vented Cooktop, induction hob with integrated hood.



BOSCH

Invented for life



The regulations around ventilation are different between countries.
Please ensure you follow your local rules and regulations.

3 | Cooktop with integrated ventilation module



1. Wall or island design? Ducted or recirculated extraction configuration?

The new cooktop with integrated ventilation module knows no limits. Whether it's a functional, space-saving wall planning or an open-plan living concept with an island design, the possibilities are endless – the new cooktop with integrated ventilation module always fits in seamlessly.

All cooktop with integrated ventilation module variants can be planned with in both ducted and recirculation extraction configurations. This means that classic kitchen planning as well as progressive design-driven concepts – including floating islands installed entirely without air ducts – can be easily realized.



In a ducted extraction configuration, a standard flat duct system discharges the cooking steams and vapours through an opening in the wall in order to eliminate the cooking odours.



In a recirculation configuration, the cooking steam is additionally filtered through powerful and durable active carbon filters that eliminate odours and are comfortably and conveniently accessible from the top of the appliance. Because of their integration into the appliance itself, the recirculation filters don't need to be installed in less accessible areas like the flat duct system or behind the drawers in base cabinet area – which further facilitates plannings and expands the design options. Recirculation configurations are possible as unducted, partly ducted or fully ducted configurations in order to meet any design requirements or preferences.

2. For the first time, cabinet configuration plannings can be realized with 60 cm wide base cabinets.

Appliance variants for 60 cm base cabinets



Appliance variants for ≥ 80 cm base cabinets



60 cm base cabinets

| Appliance variants | Worktop cut-out | Cooktop |
|-------------------------|-----------------|-------------------|
| Serie 8 | | |
| Top mounted plannings | 560 x 490 mm | |
| Flush mounted plannings | 672 x 500 mm | |
| Serie 6 | | |
| Top mounted plannings | 560 x 490 mm | PVQ795F25E |
| Flush mounted plannings | 672 x 500 mm | |
| Serie 4 | | |
| Top mounted plannings | 560 x 490 mm | PIE695B15E |
| Flush mounted plannings | 672 x 500 mm | |

80 cm base cabinets

| Appliance variants | Worktop cut-out | Cooktop |
|-------------------------|-----------------|-------------------|
| Serie 8 | | |
| Top mounted plannings | 750 x 490 mm | PXX895D66E |
| Flush mounted plannings | 780 x 500 mm | PXX821D66E |
| Serie 6 | | |
| Top mounted plannings | 750 x 490 mm | PVQ895F25E |
| Flush mounted plannings | 780 x 500 mm | PVQ821F25E |
| Serie 4 | | |
| Top mounted plannings | 750 x 490 mm | PIE895B15E |
| Flush mounted plannings | 780 x 500 mm | |

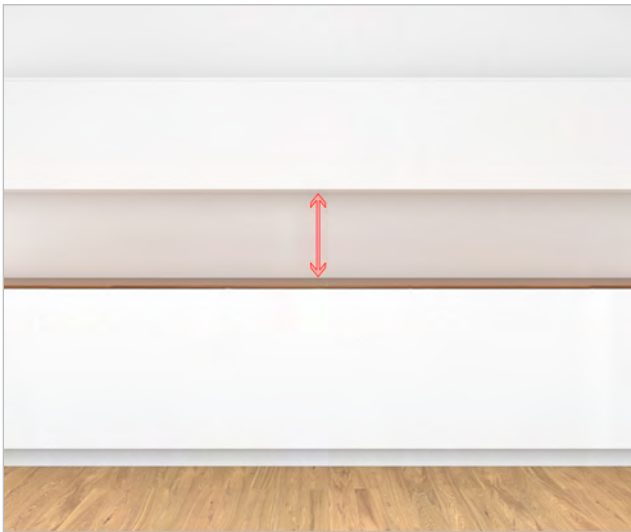

The distance between base cabinets and wall units can be chosen freely.

There are no appliance related requirements – except the easy handling of cookware that shall remain possible.



80 cm wide appliance variants can easily be planned within 60 cm wide base cabinets, too.

As with 80 cm wide cooktops without integrated ventilation module, the sidepanels of the base cabinet have to be adjusted additionally. Only the centralized ventilation chassis immerses with the full depth. The lateral wings of the chassis will enter the neighboring base units which has to be considered while planning respective drawers. It is recommended to not plan additional built-in appliances in the neighboring base units.

3. Unlimited installation accessory options allow for all market-standard configurations.

The appliance is equipped with the accessories for the most common type of installation: recirculation unducted. For other types of installation, the following accessory kits can be ordered separately.

Recirculation unducted



Included in cooktop*:



Included “Plug ‘n Play” accessory for unducted recirculation configurations. When planning a recirculated extraction scenario directly at a non-insulated exterior wall ($\mu \geq 0,5 \text{ W/m}^2 \text{ }^\circ\text{C}$), it is recommended to opt for a party or fully ducted recirculation planning.

The “Plug ‘n Play” system enables very convenient plannings and very convenient and quick installations. It includes

- 4 high-performance CleanAir odor filters with optimized odor reduction performance for cooking applications with complex odour molecules (e.g. fish). Large scale filter surfaces with high odor reduction capabilities and a lifetime of 360 hours of cooking (non-regenerative). Filters are additionally optimized for low-noise with optimized psycho-acoustics.
- A telescopic slider element with a self-gluing fixation frame to easily connect the appliance’s air outlet with the cut-out in backpanel of the furniture.
- A sealing gasquet to ensure air tightness, which can be attached on the telescopic slider or a male flat duct.

A return-flow aperture of $\geq 400 \text{ cm}^2$ is to be respected in the plinth area. This configuration requires a vertical aperture of min. 25 mm behind the backpanel of the furniture. Recommended for ideal ventilation performance are 50 mm.

Ducted extraction



HEZ9VDKE1*



Accessory for ducted extraction configurations. Includes

- 4 high-performance, low-noise acoustic filters for significantly lower noise and strongly improved psycho-acoustics.
- Vertical 90° “S” bow flat duct element (male). Suitable for worktop depths from on 60 cm.
- Connector sleeve (female) to combine male flat duct elements.
- Straight tube element (male, 500 mm).

Further ducting elements must be ordered additionally, according to the customized planning.

Recirculation partly ducted**HEZ9VDKR1 for worktop depths ≥ 60 cm***

Accessory for partly ducted recirculation configurations. Includes

- Vertical 90° "S" bow flat duct element (male). Suitable for worktop depths from on 60 cm.
- 3x Connector sleeve (female) to combine male flat duct elements.
- Straight tube element (male, 500 mm).
- Vertical 90° "L" bow flat duct element (male). Suitable for worktop depths from on 70 cm.
- Diffusor element that can be directly connected to the flat duct elements and that spreads the outflowing air in the plinth area for partly ducted recirculation configurations. The diffusor can also be directly connected to air outlet element with an adhesive tape for fully ducted recirculation configurations.

**HEZ9VDKR0 for worktop depths ≥ 70 cm***

Accessory for partly ducted recirculation configurations. Includes

- 2x Vertical 90° "L" bow flat duct element (male). Suitable for worktop depths from on 70 cm.
- 3x Connector sleeve (female) to combine male flat duct elements.
- Straight tube element (male, 500 mm).
- Diffusor element that can be directly connected to the flat duct elements and that spreads the outflowing air in the plinth area for partly ducted recirculation configurations. The diffusor can also be directly connected to air outlet element with an adhesive tape for fully ducted recirculation configurations.

The elements enable installations in worktop heights up to 960 mm. A return-flow aperture of ≥ 400 cm² is to be respected in the plinth area.

Recirculation fully ducted**Individual configuration**

Pages 11–12 provide an overview of all available flat-duct accessory elements. These can be ordered individually, enabling every customized planning.

A return-flow aperture of ≥ 400 cm² is to be respected in the plinth area.



4. Notes on exterior wall plannings and installations in recirculation configurations.



Next to well-insulated exterior walls ($\mu < 0,5 \text{ W/m}^2 \text{ }^\circ\text{C}$), all recirculation configurations are possible.



Next to uninsulated exterior walls ($\mu \geq 0,5 \text{ W/m}^2 \text{ }^\circ\text{C}$), a partly or fully ducted recirculation configuration is recommended in order to minimize any potential condensation risk.

Next to interior walls and for island designs, all recirculating configurations are also possible.

| Insulation of exterior wall | Device planning | Ducted extraction | Recirculated extraction | | |
|---|----------------------------|-------------------|-------------------------|---------------|----------|
| | | Fully ducted | Fully ducted | Partly ducted | Unducted |
| Non-insulated exterior wall ($\mu \geq 0.5 \text{ W/m}^2\text{ }^\circ\text{C}$) | Exterior wall installation | ● | ● | ● | – |
| | Interior wall installation | ● | ● | ● | ● |
| | Island installation | ● | ● | ● | ● |
| Insulated exterior wall ($\mu < 0.5 \text{ W/m}^2\text{ }^\circ\text{C}$) | Exterior wall installation | ● | ● | ● | ● |
| | Interior wall installation | ● | ● | ● | ● |
| | Island installation | ● | ● | ● | ● |

5. Flat-duct accessory elements from Bosch.

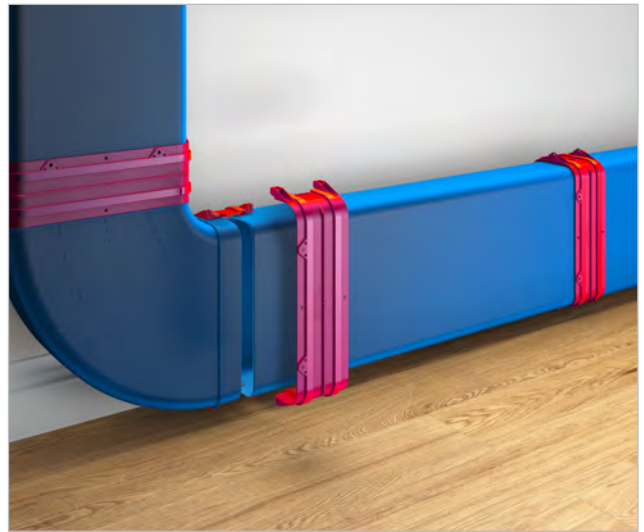

The new Bosch flat duct system offers a maximum of flow-rates and flexibility combined with an unprecedented ease of installation even in complex situations.

The simple basic principle: "Male" parts can be easily and airtightly connected by a two-part, clip-on, "female" connector sleeve element. The integrated seal eliminates the need for the usual adhesive (duct) tapes. The connector sleeves give the system a clear advantage even in complex situations to be able to connect duct elements quickly and easily. Straight elements are easy to cut to size.

The system's elements are designed and optimized for ductings in combination with all offered Bosch ventilation solutions. Aerodynamic optimization provides highest flow rates and ensures ideal appliance performances even with longer ductings.

The materials used in all elements do offer the utmost safety and comply with the highest standards: The Needle Flame Test (according to IEC 60695-11-5) and the B1/B2 building material class (according to DIN 4102-1).

5. Flat-duct accessory elements from Bosch.



HEZ9VDS1
Connector sleeve (female) to combine male flat duct elements.

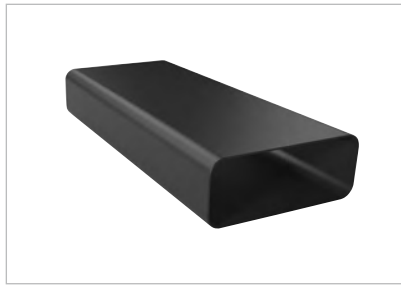

HEZ9VDSM1
Straight tube element (male, 500 mm).

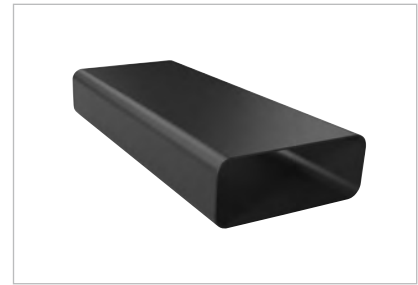

HEZ9VDSM2
Straight tube element (male, 1000 mm).

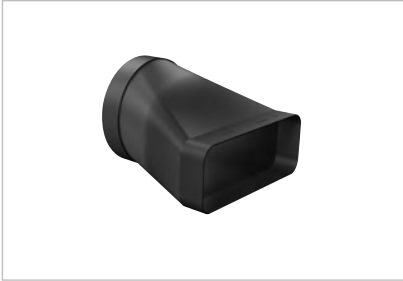

HEZ9VDSI0
Male adaptor element to combine round- and flat duct elements.



HEZ9VDSI1
Male 90° adaptor element to combine round- and flat duct elements.



HEZ9VDSB1
Horizontal 90° bow flat duct element (male).



HEZ9VRPD1
Diffusor element for partly or fully ducted recirculation.



HEZ9VDS2
Flexible, female sleeve element to combine male flat duct elements.



**HEZ9VDSB4**

Vertical 90° "S" bow flat duct element (male).
Suitable for worktop depths from on 60 cm.

**HEZ9VDSB3**

Vertical 90° "M" bow flat duct element (male).
Suitable for worktop depths from on 65 cm.

**HEZ9VDSB2**

Vertical 90° "L" bow flat duct element (male).
Suitable for worktop depths from on 70 cm.

**HEZ9VDSB4**

The vertical 90° "S" bow with a tight radius enables a ducting within the furniture and offers (in respect to the positioning of the worktop) a minimum space of 448 mm for the base unit's drawers.

**HEZ9VDSB3**

The vertical 90° "M" bow with a medium radius enables a ducting (partly) within the furniture and offers (in respect to the positioning of the worktop) a minimum space of 475 mm for the base unit's drawers.

**HEZ9VDSB2**

The vertical 90° "L" bow with a large radius enables a ducting behind backpanel of the furniture and offers (in respect to the positioning of the worktop) maximum space for full drawer depths in the base unit.

6. Notes on drawer depths and countertop depths.



The drawer depth possible and the worktop depth required depend on the selected ducting configuration and – depending on the planning scenario – the vertical 90° flat duct bow element used.

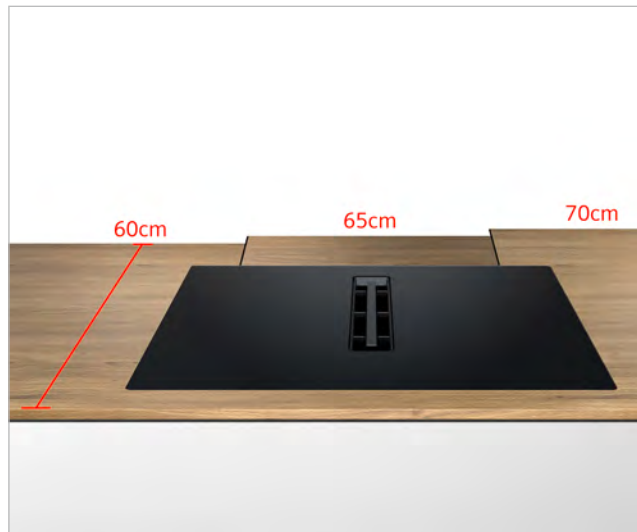

Planning scenarios in unducted recirculation configurations offer most convenient planning options.

The installation accessory with its flexible, telescopic part connects the appliances's air outlet with the backpanel of the furniture. Since there are no further ducting elements necessary, planning is possible with full drawer depths and worktop depths from on 60 cm.

Planning scenarios with ducted configurations do need vertical 90° flat duct bow elements. These elements do offer different characteristics in respect to the bow element chosen.



The vertical 90° "S" bow with a tight radius enables a ducting* within the furniture and offers (in respect to the positioning of the worktop) a minimum space of 448 mm for the base unit's drawers.

This enables worktop depths from on 60 cm. The "S" bow is part of the accessory kit HEZ9VDKR1.

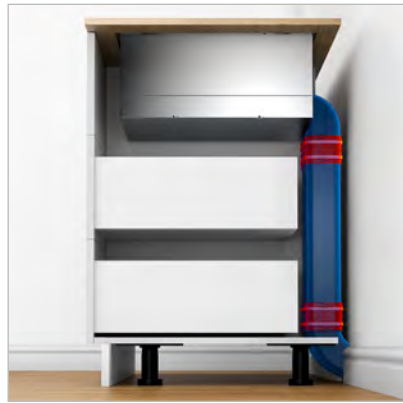

The vertical 90° "M" bow with a medium radius enables a ducting* (partly) within the furniture and offers (in respect to the positioning of the worktop) a minimum space of 475 mm for the base unit's drawers.

This enables worktop depths from on 65 cm.



The vertical 90° "L" bow with a large radius enables a ducting* behind backpanel of the furniture and offers (in respect to the positioning of the worktop) maximum space for full drawer depths in the base unit.

This enables worktop depths from on 70 cm. The "L" bow is part of the accessory kit HEZ9VDKR0.

*The characteristics are applicable for all configurations with ducted air: Partly or fully ducted recirculation and (fully) ducted extraction plannings.

7. Notes on immersion depths and Kitchen matrix systems.

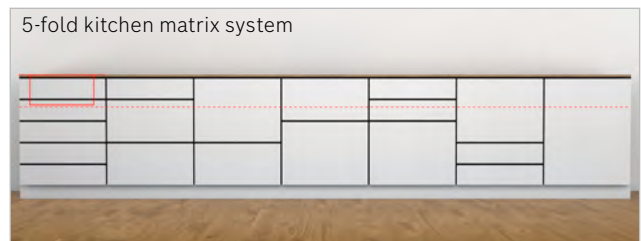
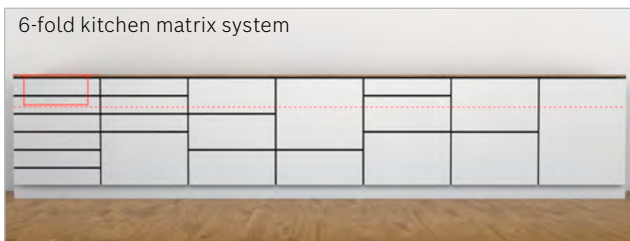

The immersion depth is 223 mm for top mounted installations and 227 mm for flush mounted installations. Generally all standard kitchen matrix systems and dimensions are possible. The installation depth required by the cooktop with integrated ventilation module means that it only blocks the storage space in the top drawer.

In case the immersion depth exceeds the intended dimensions of the top fixed panel, plannings are still possible if the second drawer's frames and side panels and its contents carry less height than the front panel itself. Although the cooktop with integrated ventilation module then extends partway into this area, it doesn't interfere with the drawer's free movement.

If the front panel is the same height as the drawer frames and content, it may not be possible to use the second drawer.



8. Notes on worktop thickness.



Installation of the cooktop with integrated ventilation module requires an installation thickness ≥ 16 mm.



If the countertop is thinner than 16 mm, the cooktop with integrated ventilation module can still be easily installed. Simply ensure that an installation depth ≥ 16 mm is achieved in the installation area – for example, by doubling the material.

The thinner the installation thickness and worktop, the more important it is to ensure its bearing capacity and stability. The cooktop with integrated ventilation module's own weight combined with a full load of pots and their contents can weigh as much as 60 kg. The worktop must be able to provide this level of stability. The worktop manufacturer's structural integrity specifications are to be taken into account.

9. Notes on ducted extraction plannings.



The highly pressure drop resistant blower with modern and efficient BLDC-technology enables longer and more complex ducting scenarios up to 8 meters with 4 90° bow elements and still offer adequate ventilation performance. This covers the majority of all ducted extraction planning. Even longer plannings are also possible, yet will reduce the performance of the integrated ventilation system.

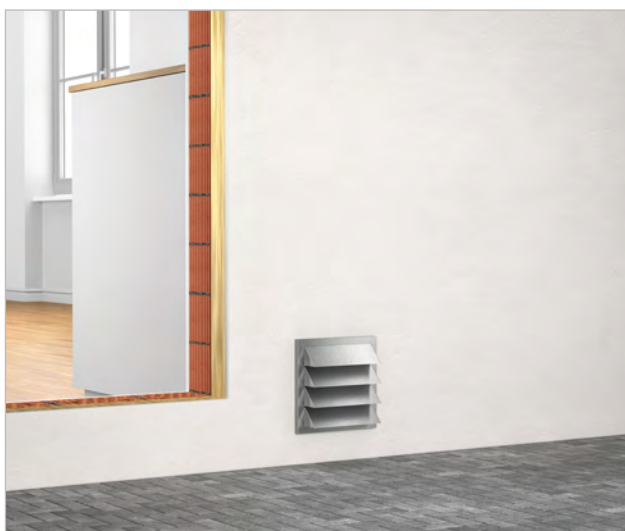

If the exhaust air is led through the outer wall, a mechanical telescopic wall outlet unit (Ø 150 mm) with (integrated) backflow flap should be used. A maximum opening pressure of 65 Pa must be taken into account. The backflow flap and wall box can be obtained from specialist dealers.

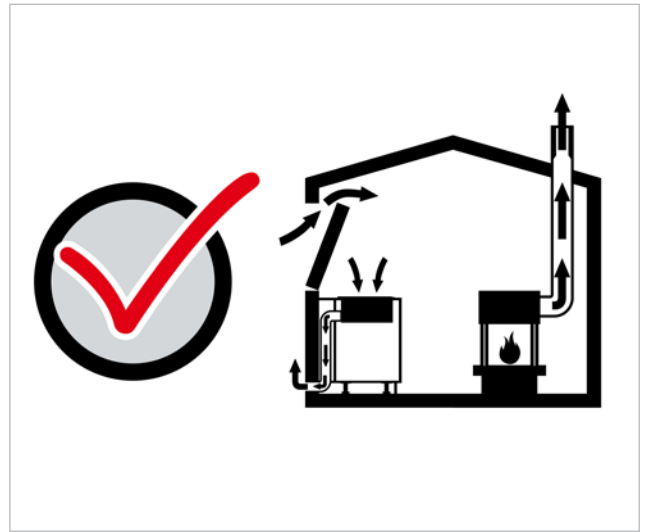

Ensuring sufficient supply air is critical in a room air-dependent fireplace (if the appliance is planned and operated in ducted extraction mode):

Safe operation is only possible if the negative pressure in the room where the fireplace is located does not exceed 4 Pa (0.04 mbar). This can be achieved if, for example, a window contact switch is installed. This device allows the air required for combustion to flow in. The window contact switch can be obtained from specialist dealers. The installation instructions for the window contact switch must be observed.

The cooktop with integrated ventilation module offers a connection option for a window contact switch with a two- or three-phase connection. The supplied connection cable (5G2.5 mm²) is installed, with a phase for a window contact switch available. With a connection 2N/3N, phase L1 (gray) corresponds to the fan motor. Hints can be found on the electrical connection diagram on the device ("fan").

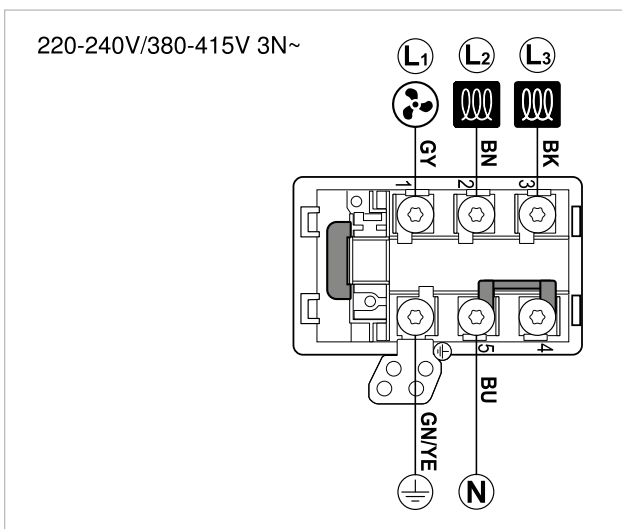

Exemplary connection diagram for a 3-phase electrical connection.

10.1 Dimensional drawings of top mounted cooktop with integrated ventilation module variants.

Cooktop with integrated ventilation module variants for **60 cm** base cabinets

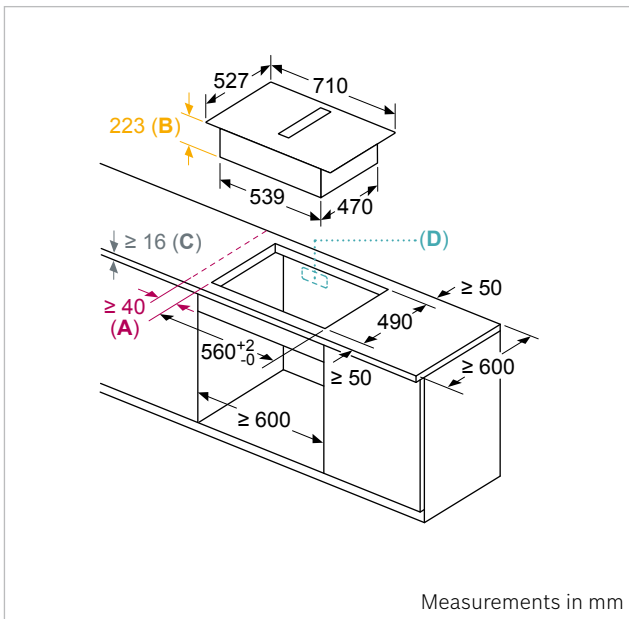

PVQ795F25E

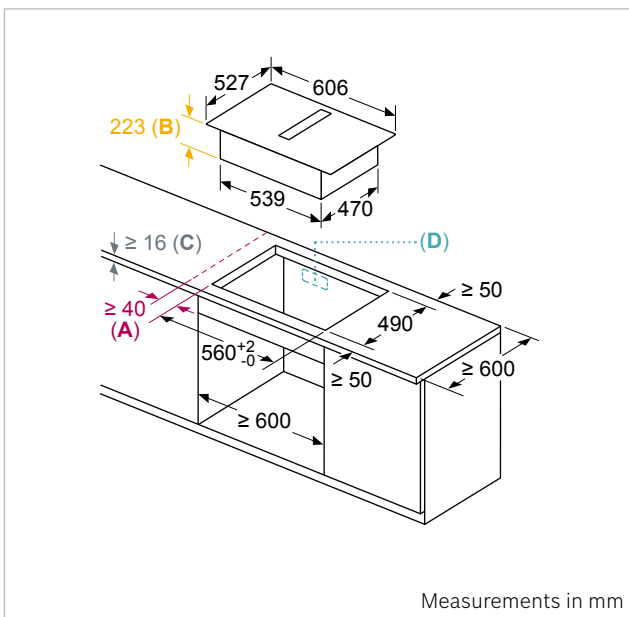

PIE695B15E

A – Minimum distance between cut-out and wall.

B – Immersion depth.

C – The worktop into which the appliance is installed should be able to withstand loads up to approximately 60 kg – if necessary using suitable substructures.

D – A cut-out in the furniture's backpanel is necessary for ductings.
The exact size and position can be taken from specific drawings.

Cooktop with integrated ventilation module variants for
≥ 80 cm base cabinets

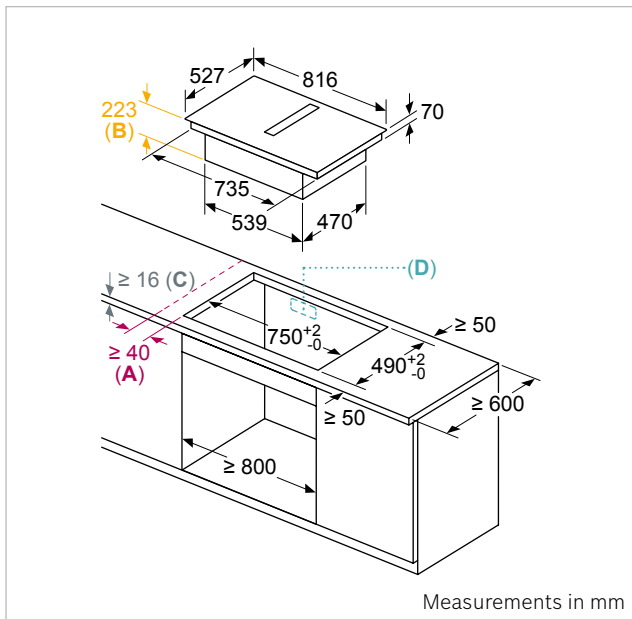

PXX895D66E | PVQ895F25E | PIE895B15E

A – Minimum distance between cut-out and wall.

B – Immersion depth.

C – The worktop into which the appliance is installed should be able to withstand loads up to approximately 60 kg – if necessary using suitable substructures.

D – A cut-out in the furniture's backpanel is necessary for ductings.
 The exact size and position can be taken from specific drawings.

10.2 Dimensional drawings of flush mounted cooktop with integrated ventilation module variants.

Cooktop with integrated ventilation module variants for **60 cm** base cabinets

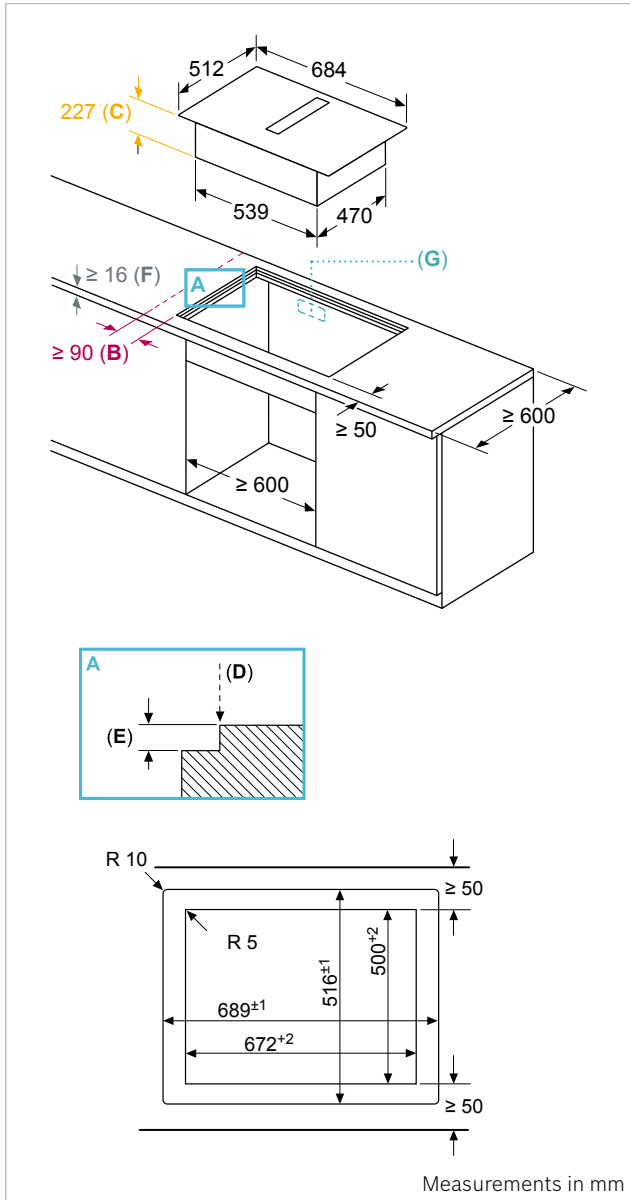

PVQ721F25E

Cooktop with integrated ventilation module variants for **≥ 80 cm** base cabinets

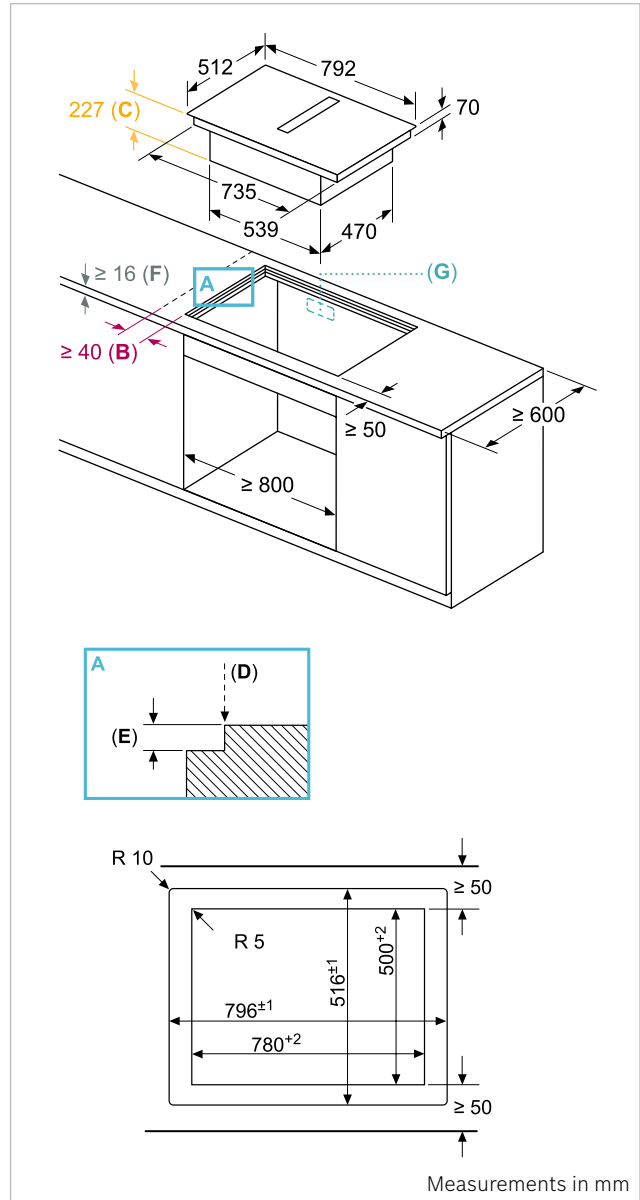

PXX821D66E | PVQ821F25E

A - Detail drawing.

B - Minimum distance between cut-out and wall.

C - Immersion depth.

D - Max. chamfer 1.

E - $6.5^{+0.5}$.

F - The worktop into which the appliance is installed should be able to withstand loads up to approximately 60 kg - if necessary using suitable substructures.

G - A cut-out in the furniture's backpanel is necessary for ductings.

The exact size and position can be taken from specific drawings.

10.3 80 cm cooktop with integrated ventilation module variants in 60 cm base units.

Cooktop with integrated ventilation module variants for **top-mounted** plannings

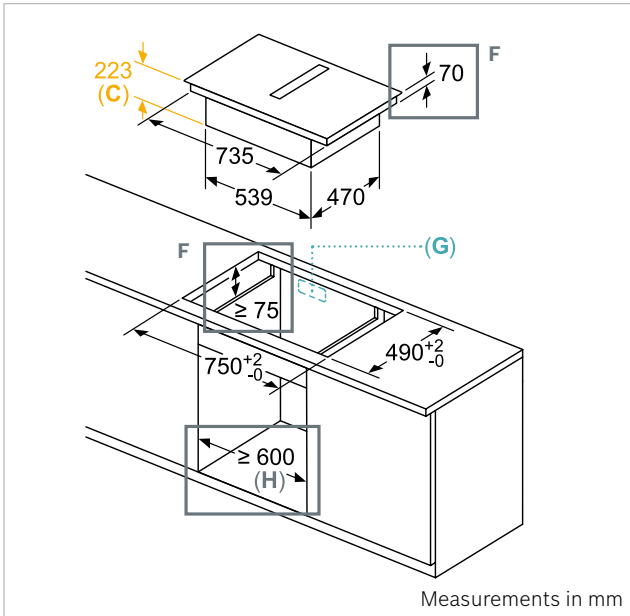

PXX895D66E | PVQ895F25E | PIE895B15E

Cooktop with integrated ventilation module variants for **flush-mounted** plannings

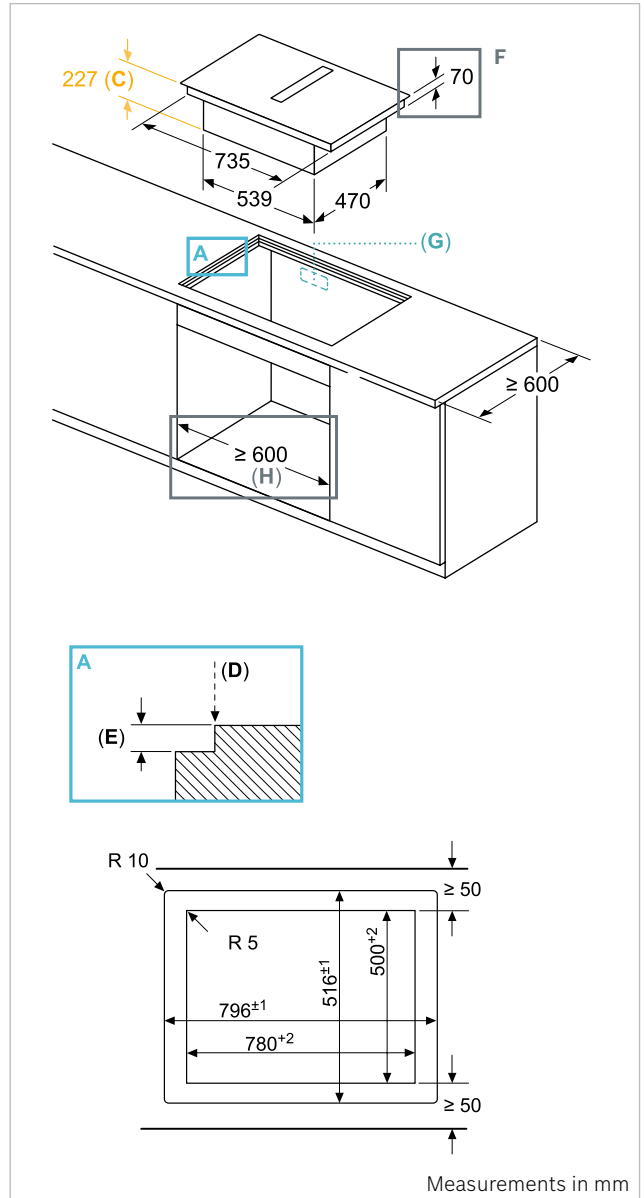

PXX821D66E | PVQ895F25E

A – Detail drawing

B – Minimum distance between cut-out and wall.

C – Immersion depth.

D – Max. chamfer 1.

E – $6.5^{+0.5}$.

F – The worktop into which the appliance is installed should be able to withstand loads up to approximately 60 kg – if necessary using suitable substructures.

G – A cut-out in the furniture's backpanel is necessary for ductings.

The exact size and position can be taken from specific drawings.

H – All 80 cm device variants can be installed in a 60 cm wide base units.

The side panels of the furniture have to be shortened, as only the centralized, 539 mm wide ventilation chassis reaches the full immersion depth.

10.4 Dimensional drawings of the air outlet on cooktop with integrated ventilation module.

Cooktop with integrated ventilation module variants for **60 cm** base cabinets

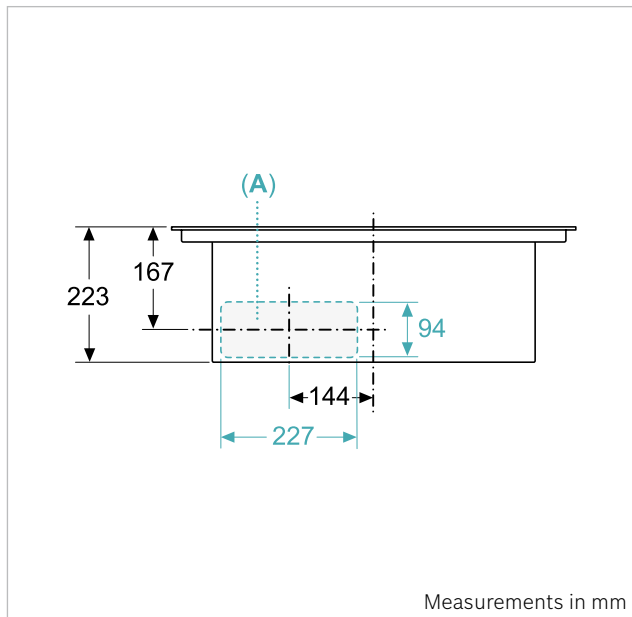

Cooktop with integrated ventilation module variants for **top-mounted** plannings
PVQ795F25E | PIE695B15E

cooktop with integrated ventilation module variants for **≥ 80 cm** base cabinets

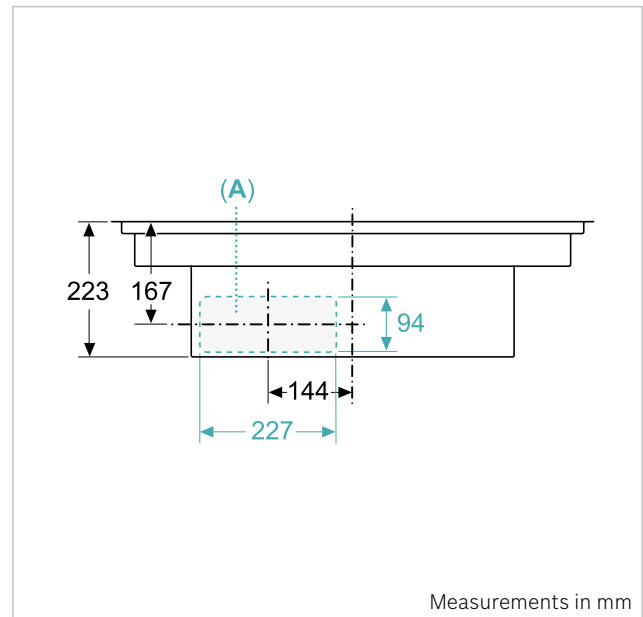

Cooktop with integrated ventilation module variants for **top-mounted** plannings
PXX895D66E | PVQ895F25E | PIE895B15E

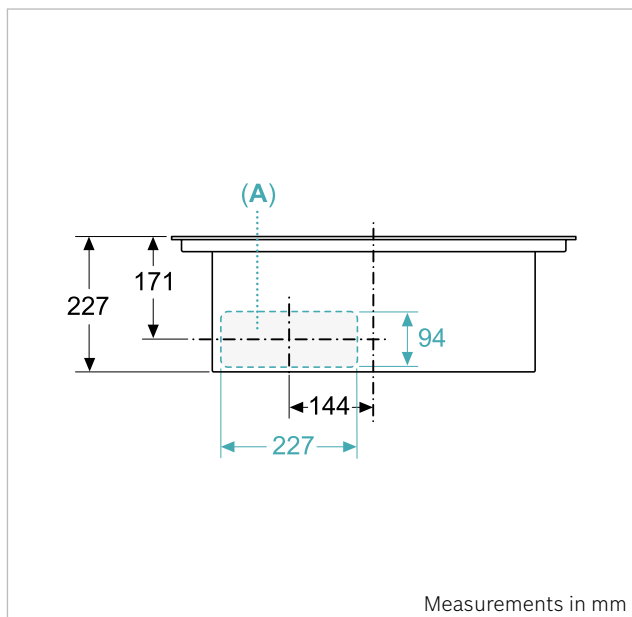

Cooktop with integrated ventilation module variants for **flush-mounted** plannings
PVQ721F25E

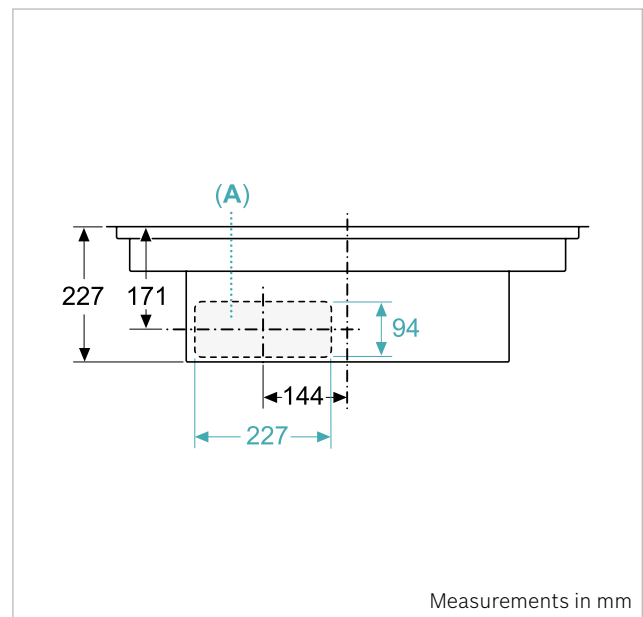

Cooktop with integrated ventilation module variants for **flush-mounted** plannings
PXX821D66E | PVQ821F25E

A – Connected directly at the rear.

10.5 Dimensional drawings for installations in unducted recirculation configurations.

Side view:

cooktop with integrated ventilation module variants for **60 cm** and ≥ 80 cm base cabinets

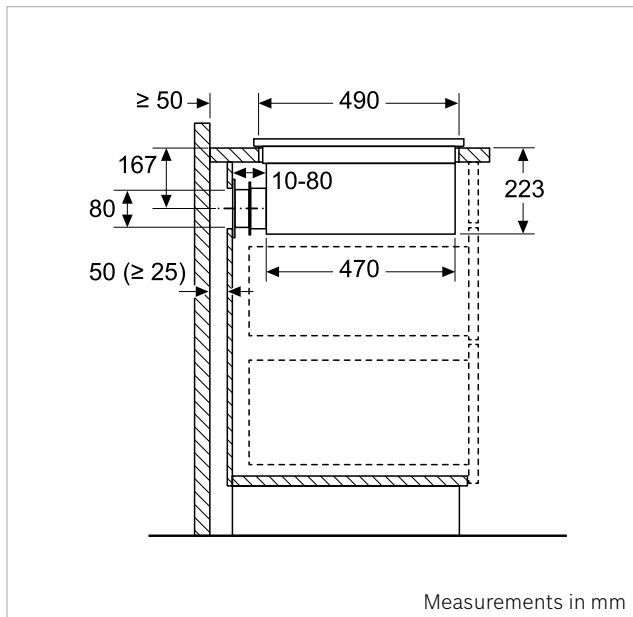

Cooktop with integrated ventilation module variants for **top-mounted** plannings
PIE695B15E | PVQ795F25E | PXX895D66E | PVQ895F25E | PIE811B15E

Position of the cut-out within the backpanel of the furniture:

cooktop with integrated ventilation module variants for **60 cm** and ≥ 80 cm base cabinets

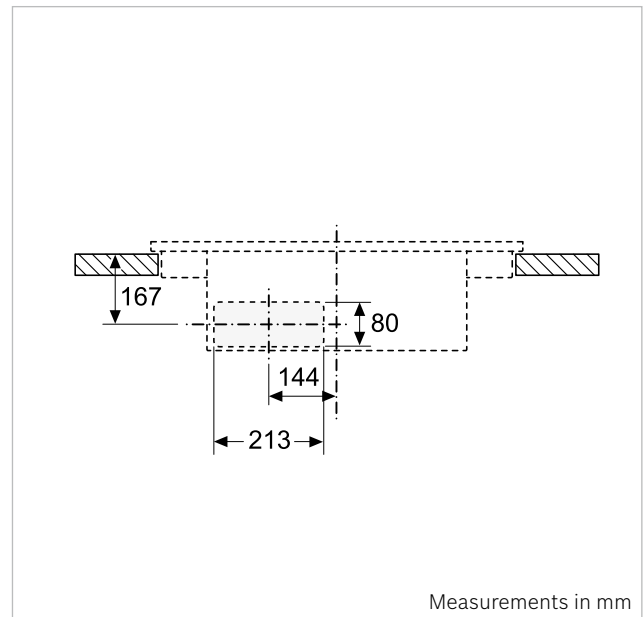

Cooktop with integrated ventilation module variants for **top-mounted** plannings
PIE695B15E | PVQ795F25E | PXX895D66E | PVQ895F25E | PIE811B15E

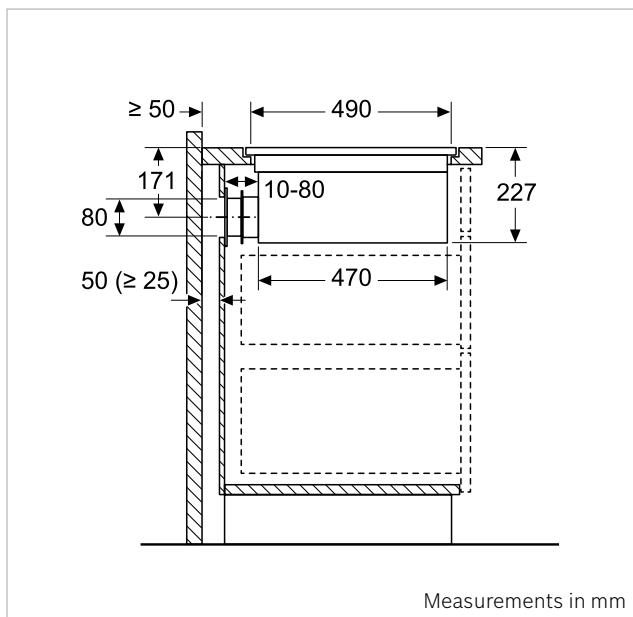

Cooktop with integrated ventilation module variants for **flush-mounted** plannings
PVQ721F25E | PXX821D66E | PVQ821F25E

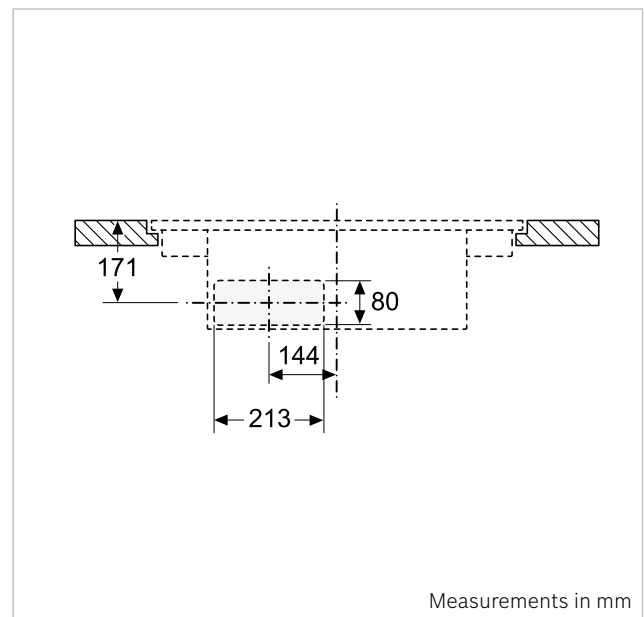

Cooktop with integrated ventilation module variants for **flush-mounted** plannings
PVQ721F25E | PXX821D66E | PVQ821F25E

On non-insulated or poorly insulated exterior walls ($\mu \geq 0,5 \text{ W/m}^2 \text{ } ^\circ\text{C}$), planning in a partly or fully ducted recirculation configuration is recommended in order to minimize the risk of condensation. All types of circulating air planning are possible on well-insulated external walls ($\mu < 0,5 \text{ W/m}^2 \text{ } ^\circ\text{C}$).

10.6.1 Dimensional drawings for installations in (partly) ducted recirculation and ducted extraction configurations with Bosch 90° bows.

Side view:

Cooktop with integrated ventilation module variants for **top-mounted** plannings

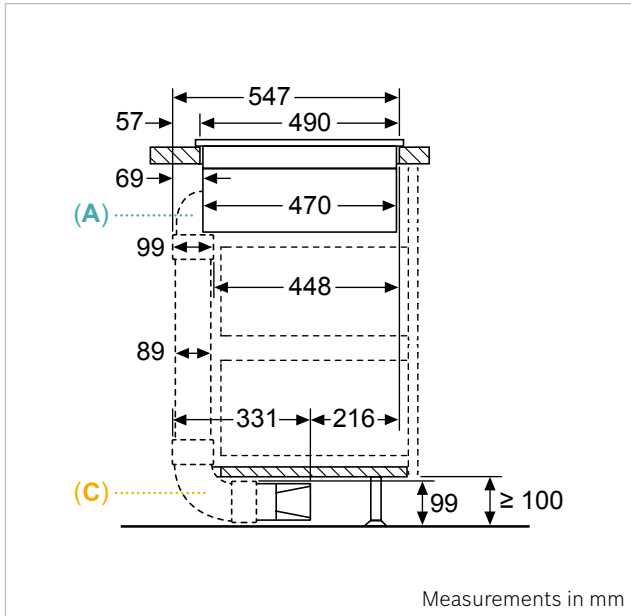

With HZ9VDSB4 (top)

Vertical 90° "S" bow flat duct element (male).

Side view:

Cooktop with integrated ventilation module variants for **flush-mounted** plannings

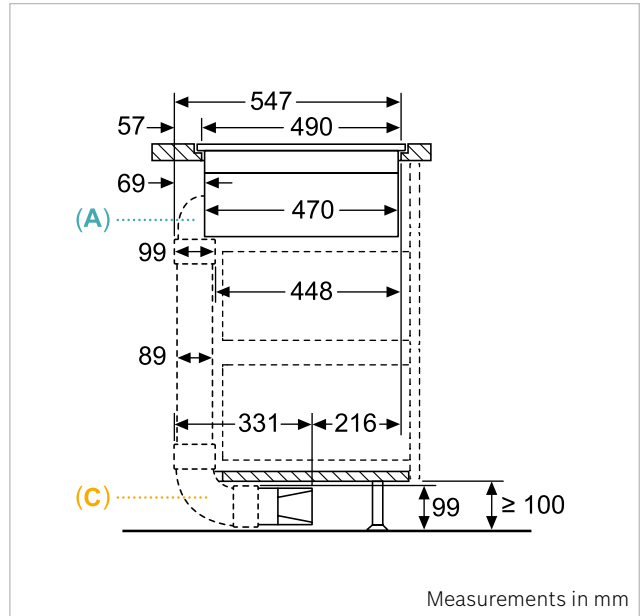

With HZ9VDSB4 (top)

Vertical 90° "S" bow flat duct element (male).

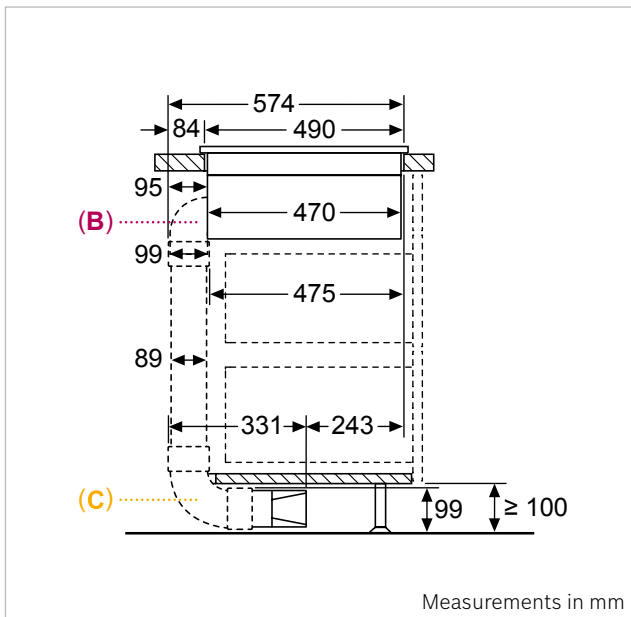

With HZ9VDSB3 (top)

Vertical 90° "M" bow flat duct element (male).

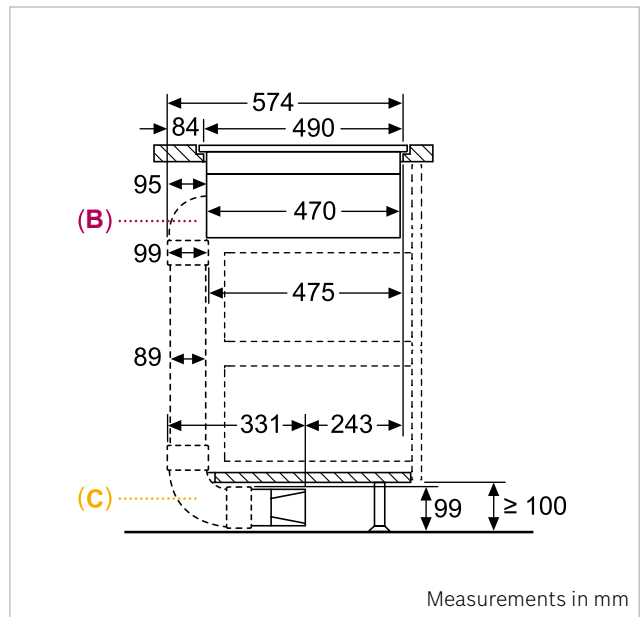

With HZ9VDSB3 (top)

Vertical 90° "M" bow flat duct element (male).

- A – 90° flat-duct element (male) "S"
- B – 90° flat-duct element (male) "M"
- C – 90° flat-duct element (male) "L"

Side view:
Cooktop with integrated ventilation module variants for **top-mounted** plannings

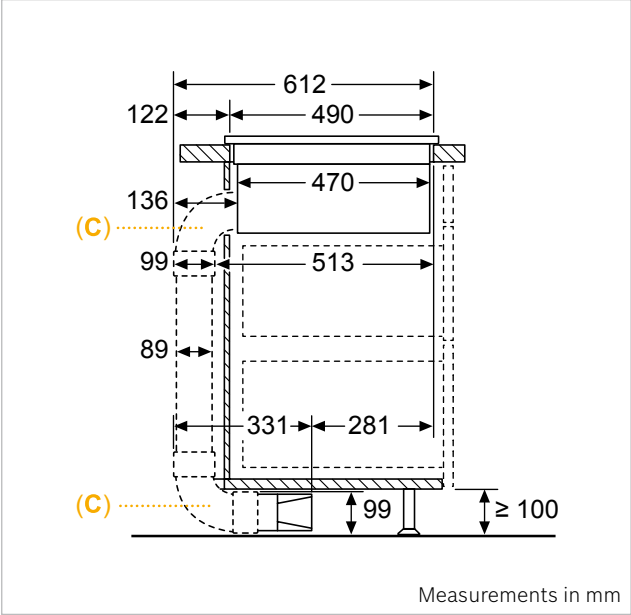

With HZ9VDSB2 (top)
Vertical 90° "L" bow flat duct element (male).

Side view:
Cooktop with integrated ventilation module variants for **flush-mounted** plannings

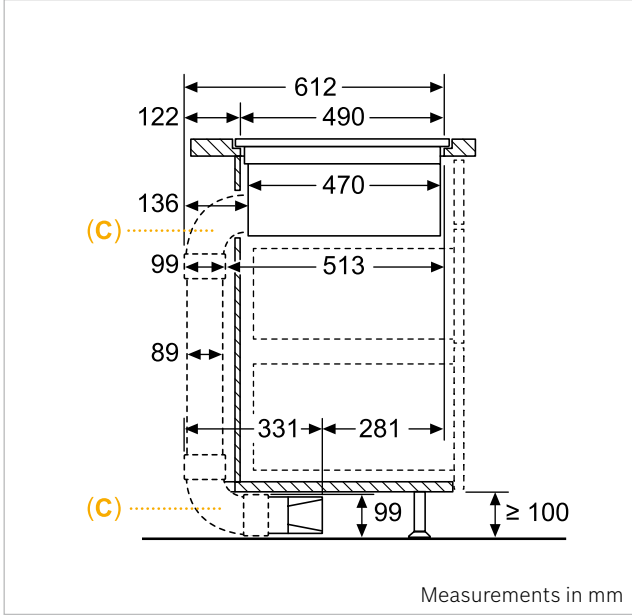

With HZ9VDSB2 (top)
Vertical 90° "L" bow flat duct element (male).

A – 90° flat-duct element (male) "S"
B – 90° flat-duct element (male) "M"
C – 90° flat-duct element (male) "L"

10.6.2 Dimensional drawings for installations in (partly) ducted recirculation and ducted extraction configurations with 3rd party 90° bows.

Side view:

Cooktop with integrated ventilation module variants for **top-mounted** plannings

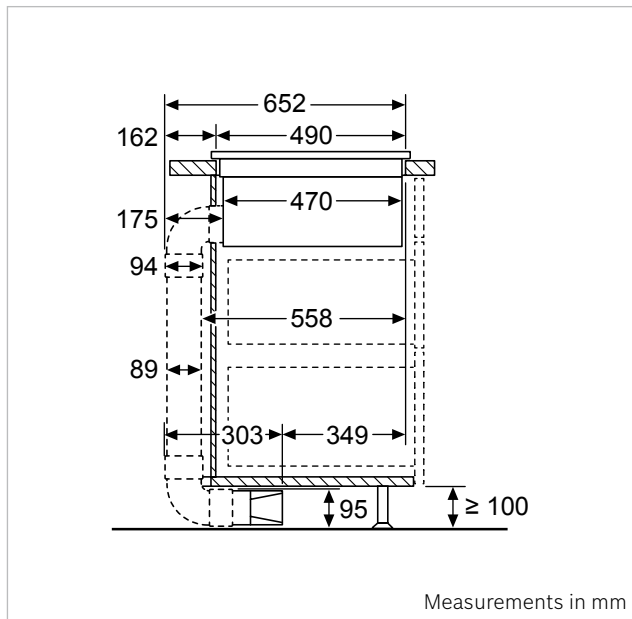

With 3rd party 90° bows

Side view::

Cooktop with integrated ventilation module variants for **flush-mounted** plannings

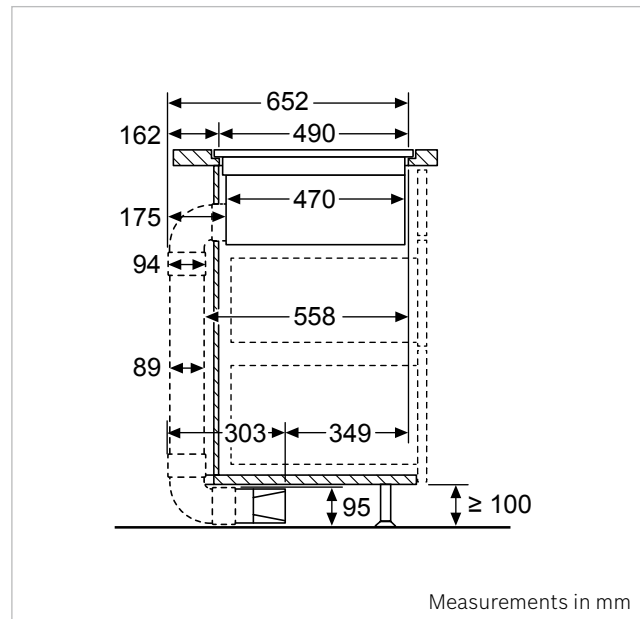

With 3rd party 90° bows

10.6.3 Dimensional drawings for installations in (partly) ducted recirculation and ducted extraction configurations.

Front view:

Cooktop with integrated ventilation module variants for **≥ 60 cm** base units

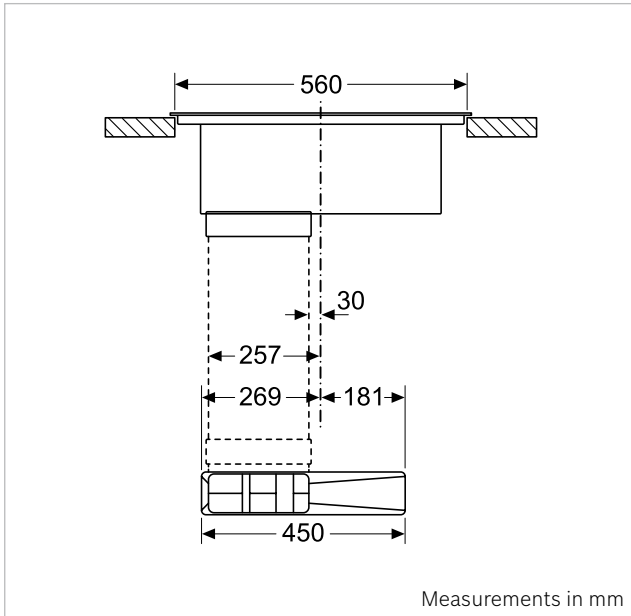

Cooktop with integrated ventilation module variants for **top-mounted** plannings
PIE695B15E | PVQ795F25E

Front view:

Cooktop with integrated ventilation module variants for **≥ 80 cm** base units

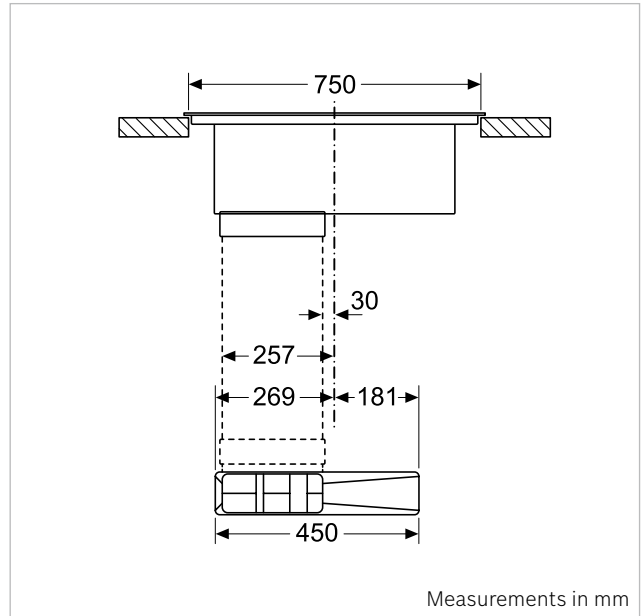

Cooktop with integrated ventilation module variants for **top-mounted** plannings
PXX895D66E | PVQ895F25E | PIE895B15E

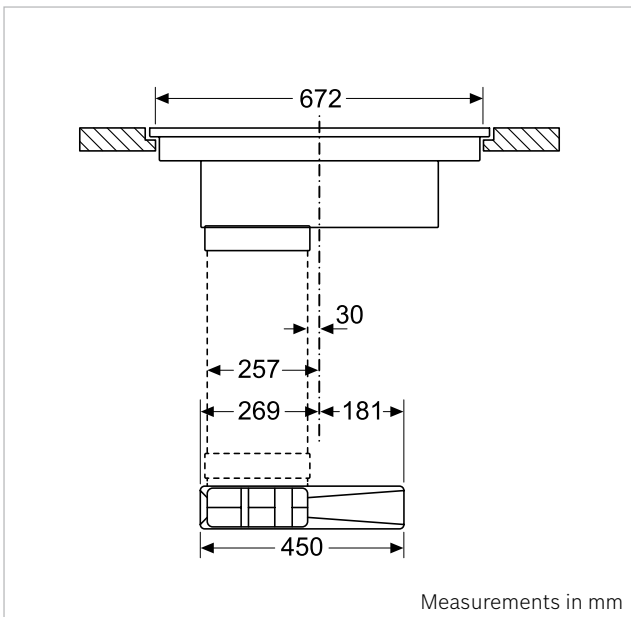

Cooktop with integrated ventilation module variants for **flush-mounted** plannings
PVQ721F25E

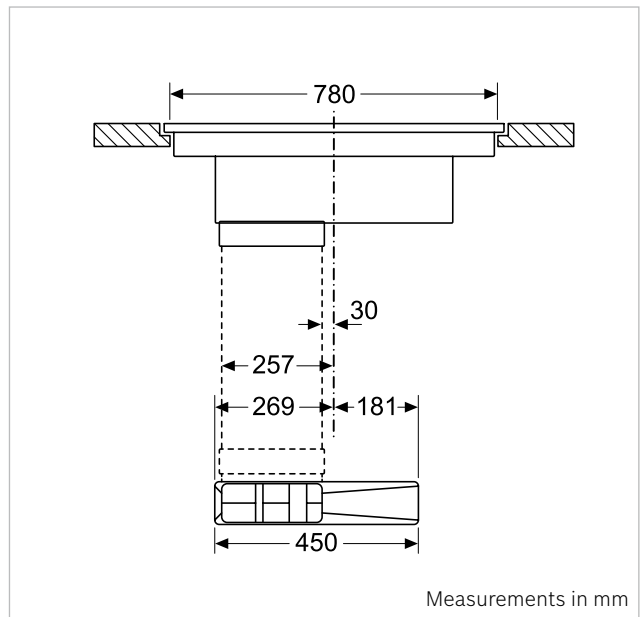

Cooktop with integrated ventilation module variants for **flush-mounted** plannings
PXX821D66E | PVQ821F25E

10.7 Dimensional drawings for Bosch installation accessories / flat duct accessories.

Flat duct accessories

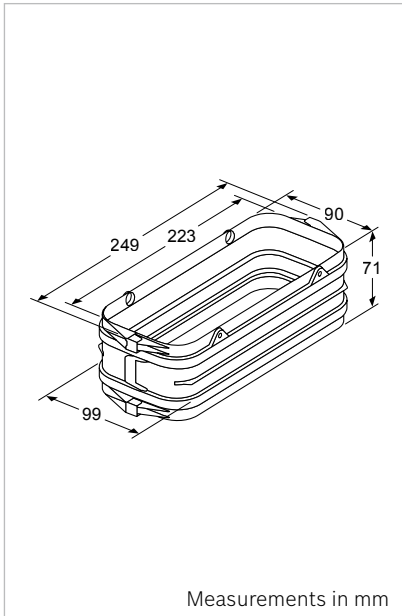

HEZ9VDSS1

Connector sleeve (female) to combine male flat duct elements.

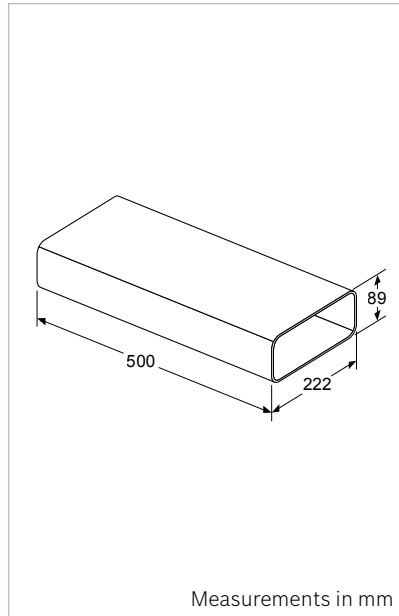

HEZ9VDSM1

Straight tube element (male, 500 mm).

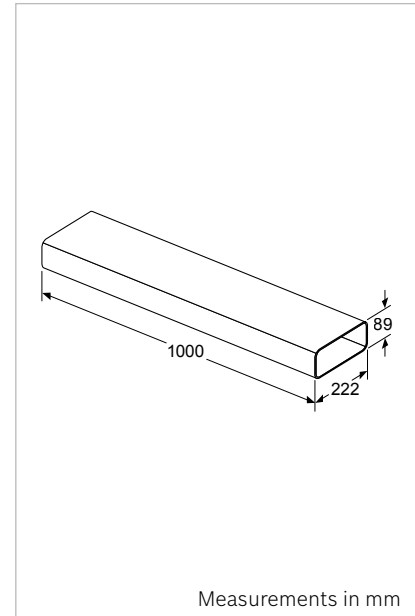

HEZ9VDSM2

Straight tube element (male, 1000 mm).

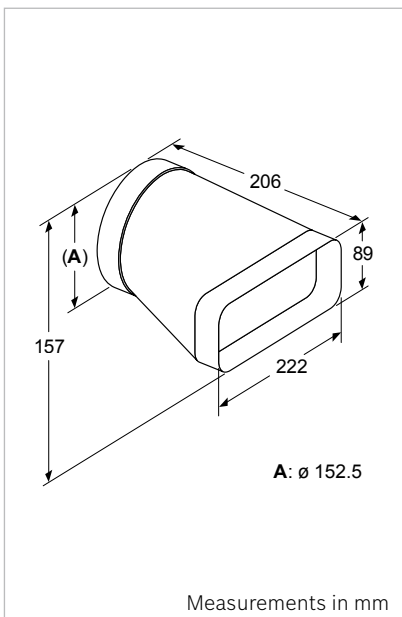

HEZ9VDSIO

Male adaptor element to combine round- and flat duct elements.

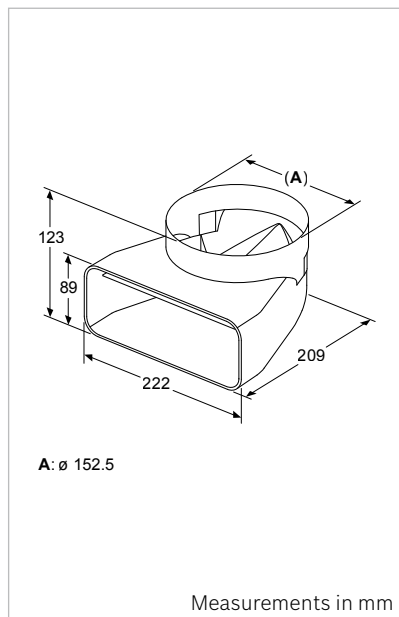

HEZ9VDSI1

Male 90° adaptor element to combine round- and flat duct elements.

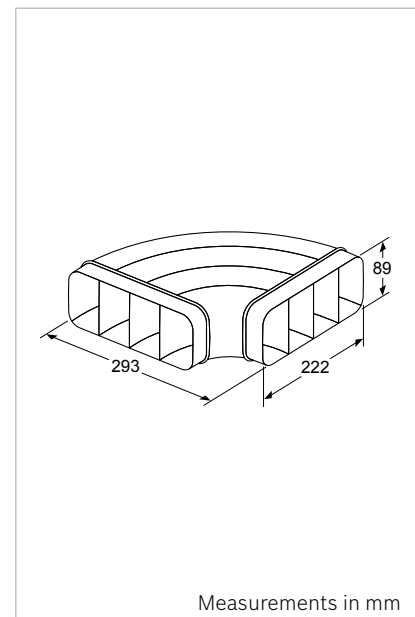

HEZ9VDSB1

Horizontal 90° bow flat duct element (male).

All elements are having a (outer) corner radius of 20 mm.

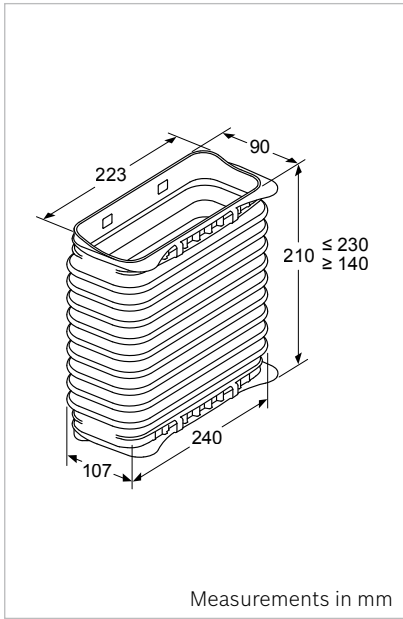

HEZ9VDSS2

Flexible, female sleeve element to combine male flat duct elements.

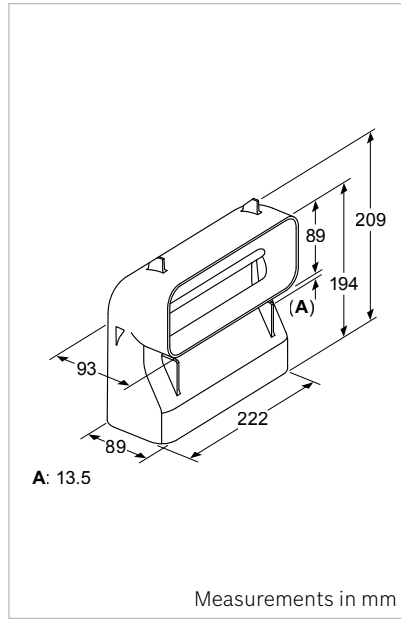

HEZ9VDSB4

Vertical 90° "S" bow flat duct element (male).

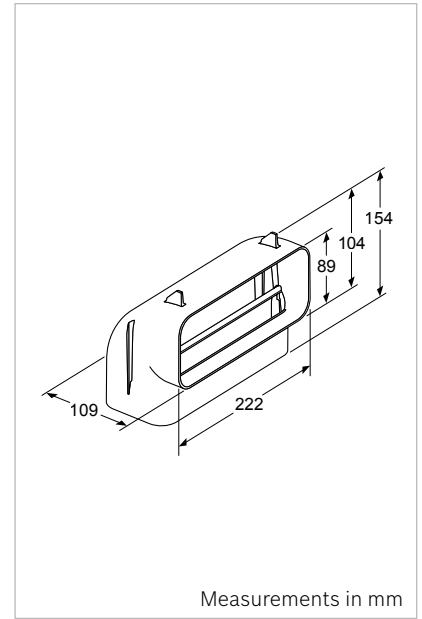

HEZ9VDSB3

Vertical 90° "M" bow flat duct element (male).

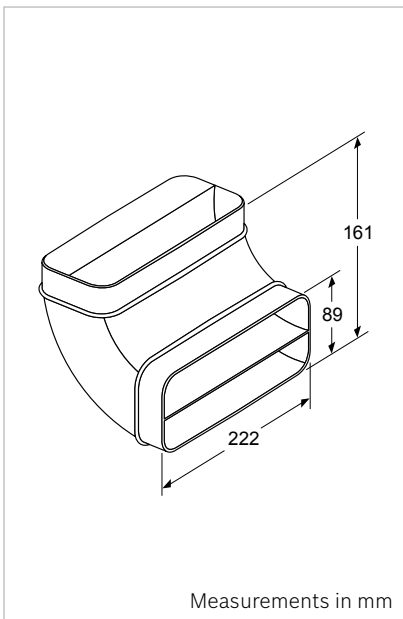

HEZ9VDSB2

Vertical 90° "L" bow flat duct element (male).

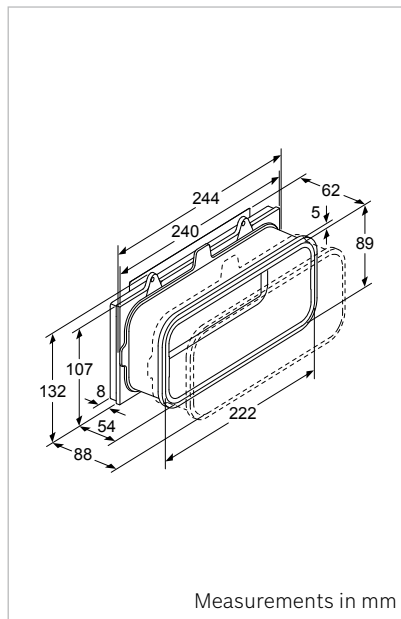

Included in cooktop

Telescopic slider element for unducted recirculation.

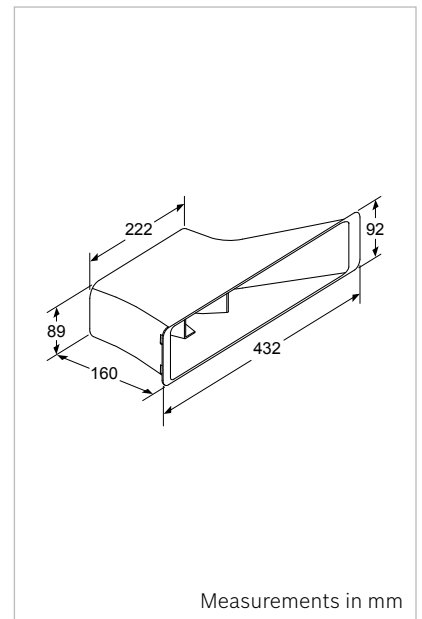

HEZ9VRPD1

Diffuser element for partly or fully ducted recirculation.

All elements are having a (outer) corner radius of 20 mm.