



# BOSCH

Invented for life



WUU28460HK Front loading washer		\$8,400
<b>Design</b>	<ul style="list-style-type: none"> <li>Series 6</li> <li>AllergyPlus: Specially developed for the needs of allergy-sensitive people</li> <li>Can be built-under</li> <li>EcoSilence Drive™: Extremely energy-efficient and quiet in operation with long lifetime.</li> <li>ActiveWater™ Plus: Automatic load adjustment system for gentle water management</li> <li>SpeedPerfect®: Time optimized program with perfect wash performance</li> </ul>	
<b>Programmes &amp; additional options</b>	<ul style="list-style-type: none"> <li>Programmes: Cottons, Eco 40-60, Cottons Colour, Synthetics, Wool, Quick 15'/30', Mix, Spin/Drain, AllergyPlus, Shirts, Jeans/Dark, Sportswear, Delicates/Silk, Drum Clean, Rinse</li> <li>Options: Temperature selection, Spin speed selection, Finish In time selection, Water &amp; Rinse Plus, Pre-wash, SpeedPerfect, Start/Reload</li> </ul>	
<b>Technology</b>	<ul style="list-style-type: none"> <li>EcoSilence Drive™: Quiet motor with long lifetime</li> <li>AntiVibration™ design: More stability and quietness, less vibration</li> <li>Super suspension system - 3 suspension axels</li> <li>VarioDrum: Comfort, spacious, gentle on fabrics, tough on stains</li> <li>Electronic control dials and Large LED-Display</li> <li>ActiveWater™ Plus and Flow sensor: Optimization of water consumption</li> <li>Jetsystem™: SelfCleaning detergent drawer</li> <li>3D AquaSpa wash system: Fast water penetration</li> <li>Buzzer to indicate the end of cycle</li> </ul>	
<b>Safety functions</b>	<ul style="list-style-type: none"> <li>Multiple Water Protection system</li> <li>Foam detection</li> <li>Unbalanced load detection</li> <li>Childproof lock</li> </ul>	
<b>Technical information</b>	<ul style="list-style-type: none"> <li>Washing Capacity: 8 kg</li> <li>Spin speed selection from 400-1400 rpm</li> <li>HK energy label 1</li> <li>HK water label 1</li> <li>Total connected load: 2.3kW (10A)</li> <li>Dimensions (H x W x D): 845 x 598 x 590(633*) mm</li> <li>Built-under model: WUU2846BHK: Height 820mm</li> </ul>	
<b>Country of origin</b>	<ul style="list-style-type: none"> <li>Spain</li> </ul>	

\* Included door frame thickness

Please reserve 5-10mm as buffer due to possible uneven flooring  
Please consult product hotline for installation requirement

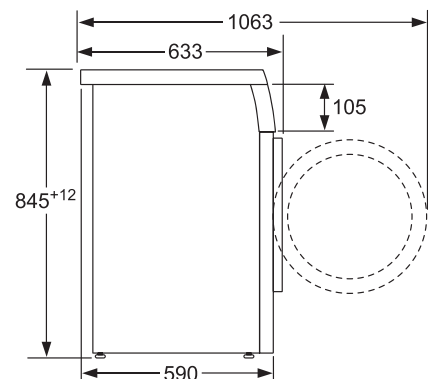
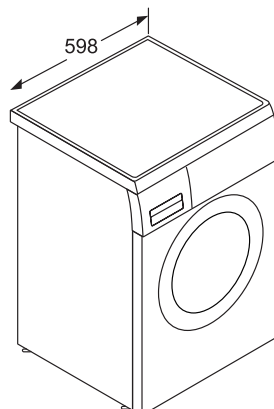

\* For major domestic appliances. Source: Euromonitor, volume sales, 2020

Measurements in mm

**BSH Home Appliances Limited**  
Customer Contact Hotline: 2626 9655 (Hong Kong) / 0800 863 (Macau local call only)  
[www.bosch-home.com.hk](http://www.bosch-home.com.hk)

• Specifications and technical information are subject to change.  
• Right of technical modification reserved, colours may vary slightly from illustrations.  
©2021 by BSH Home Appliances Limited. Reproduction, complete or in part, only with the express permission of BSH.