







BOSCH

Invented for life



GUD15AFFG		\$15,800
Built-under freezer		
   		
Performance	<ul style="list-style-type: none"> • EU Energy efficiency class: A+ (184kWh per year) • Total net capacity: 98 litres • Freezing capacity in 24 hours: 12kg • Maximum freezer storage time in power failure: 23 hours • Noise level: 38dB • Total connected load: 0.09kW (13A) 	
Key features	<ul style="list-style-type: none"> • Manual defrost freezer • Removable magnetic door seals - easy to clean and to replace 	
Additional features	<ul style="list-style-type: none"> • **** freezer • 3 freezer drawers • 1 ice cube tray • Right hinged door, door reversible • Ventilation through plinth, no cutting of worktop required 	
Functions	<ul style="list-style-type: none"> • SuperFreezing function with manual deactivation • Freezing calendar • Door open warning signal: Yes • Malfunction warning signal: visual, acoustic 	
Design	<ul style="list-style-type: none"> • Flush-folding hinge • Mechanical control • Dimensions (H x W x D): 818-868 x 598 x 548 mm 	
Country of origin	• Germany	

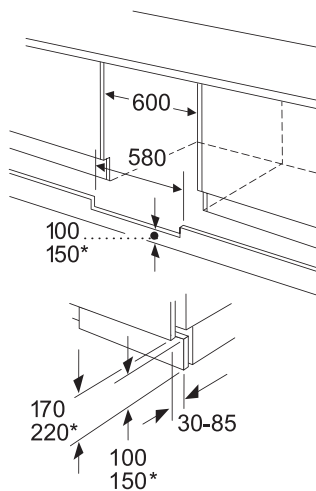

Space for electrical connection next to the appliance on the left or right-hand side.
Ventilation space in the base.

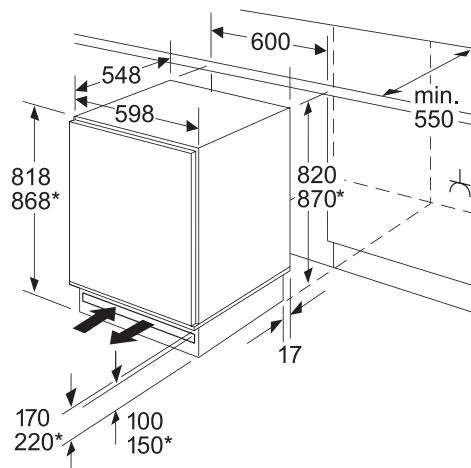

* Variable base/substructure height

Recommended gap dimensions for flat hinges

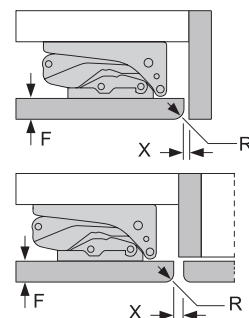

	F	R	X
16-19	0-3	2,5	
20	0-1	3	
	2-3	2,5	
21	0-1	3	
	2-3	2,5	
22	0	4	
	1	3,5	
	2-3	3	

The gap dimensions recommended in the table must be adhered to in order to ensure that appliance doors do not collide with anything when they are opened, and to avoid causing damage to kitchen units.

This appliance is best installed in a dry and/or air-conditioned room.

* For major domestic appliances. Source: Euromonitor, volume sales, 2019

Measurements in mm