

de Montageanleitung
 *) Über Kundendienst erhältlich

en Installation instructions
 *) Available from customer service

fr Notice de montage
 *) Disponible par le biais du service après-vente

nl Montagevoorschrift
 *) Tegen meerprijs bij de Servicedienst verkrijgbaar

it Istruzioni per il montaggio
 *) Disponibile presso il servizio assistenza clienti

el Οδηγίες τοποθέτησης
 *) Διατίθενται από την υπηρεσία τεχνικής εξυπηρέτησης πελατών

es Instrucciones de montaje
 *) Se puede adquirir a través del Servicio de Asistencia Técnica Oficial de la marca

pt Instruções de montagem
 *) Pode ser adquirido nos nossos Serviços Técnicos

sv Monteringsanvisning
 *) kan fås via Service

no Monteringsanvisning
 *) fåes hos kundeservice

fi Asennusohje
 *) Saatavissa huoltopalvelusta

da Monteringsvejledning
 *) Kan købes hos serviceafdelingen

tr Montaj kılavuzu
 *) Yetkili servis üzerinden alınabilir

ru Инструкция по монтажу
 *) Можно получить в сервисном центре

cs Montážní návod
 *) K dispozici přes servisní službu

pl Instrukcja montażu
 *) Do uzyskania w punkcie serwisowym

hu Szerelési utasítás
 *) A vevőszolgálaton keresztül kapható:

hr Uputa za montažu
 *) može dobiti kod službe održavanja

mk Упатство за монтажа
 *) се добива преку службата за купувачи

sl Navodilo za montažo
 *) Lahko nabavite v servisni službi

sr Uputstvo za montažu
 *) Može se nabaviti preko servisne službe

et Monteerimisjuhend
 *) küsige klienditeeninduselt

id Intruksi Pemasangan
 *) bisa didapatkan melalui Customer Service

lt Montavimo instrukcija
 *) Ją galima gauti klientų aptarnavimo servise

lv Montāžas pamācība
 *) Var saņemt servisa dienestā

sk Návod na montáž
 *) Dostanete v službe zákazníkom

sq Udhëzues për montim
 *) Sigurohet nëpërmjet servisit

bs Uputa za montažu
 *) Može se dobiti preko servisne službe

fa راهنمایی مونتاژ
 *) از مرکز خدمات پس از فروش تهیه فرمائید

ar تعليمات التركيب
 *) يمكن طلبها من مراكز خدمة العملاء

ko 설치 설명서
 *) 고객센터 센터에서 구입 가능

zh 安装说明书
 *) 可向售后服务站索取。

uk Інструкція з монтажу
 *) Можна отримати через сервісну службу

ro Instrucțiune de montaj
 *) obținabilă la serviciul pentru clienți

kk Іске қосу туралы нұсқаулар!
 *) Сервис қызмет көрсету орталығында алуына жатады

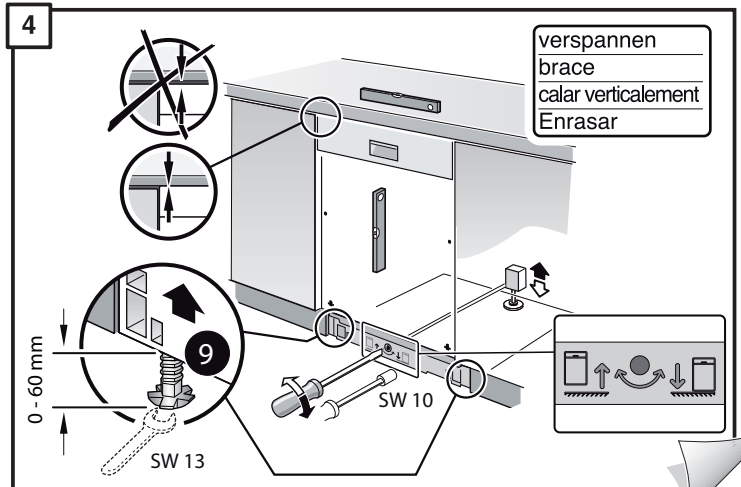
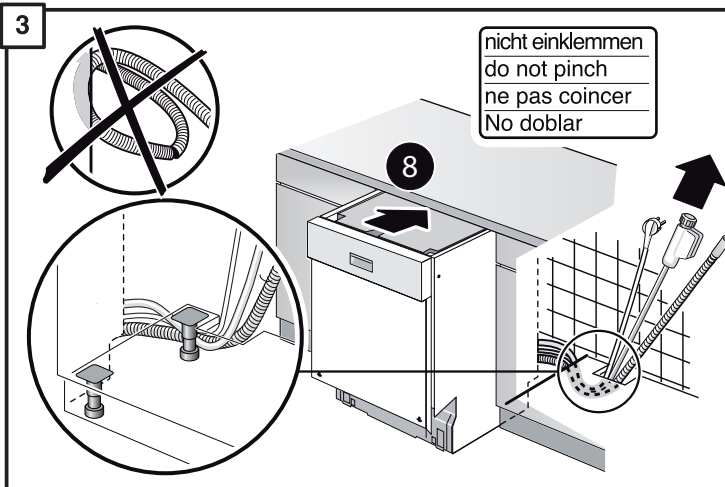
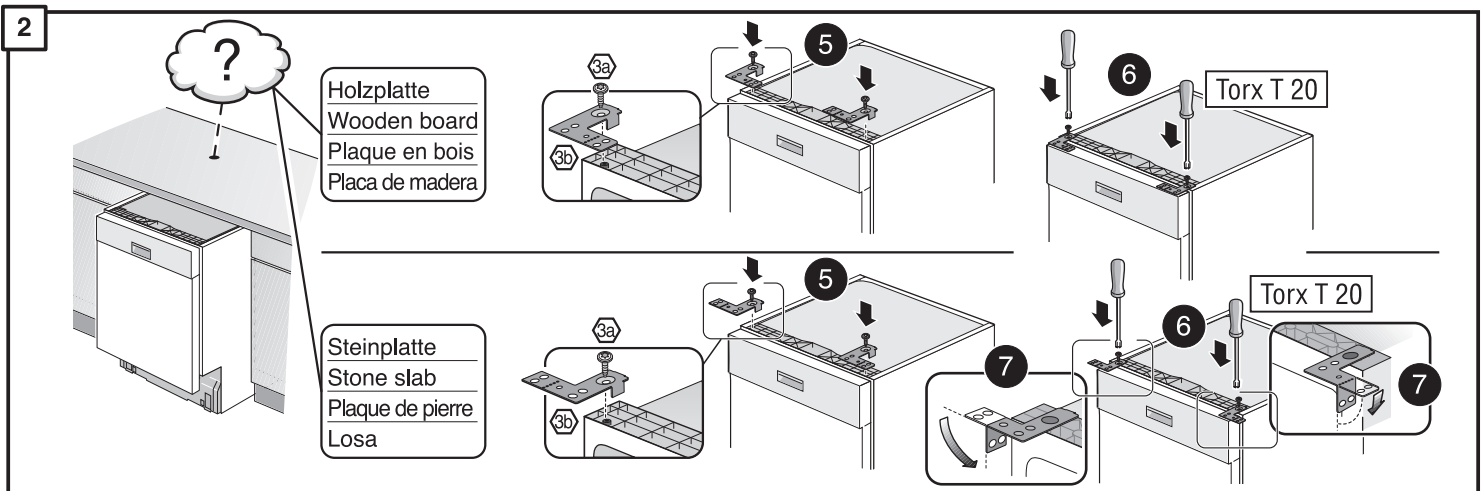
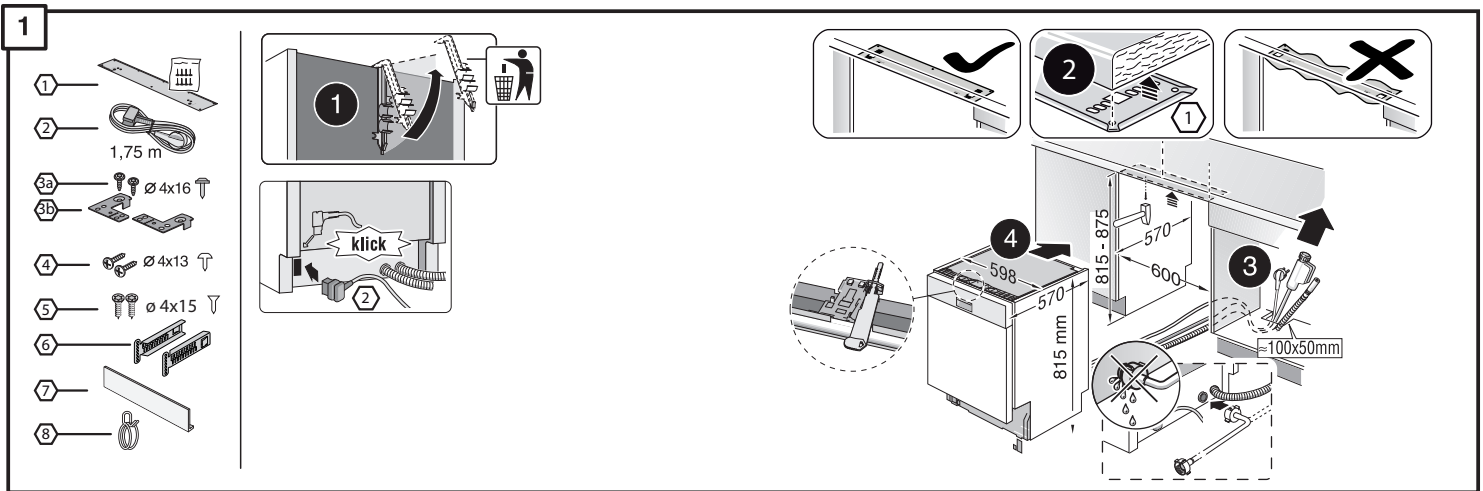

5

Holzplatte
Wooden board
Plaque en bois
Placa de madera



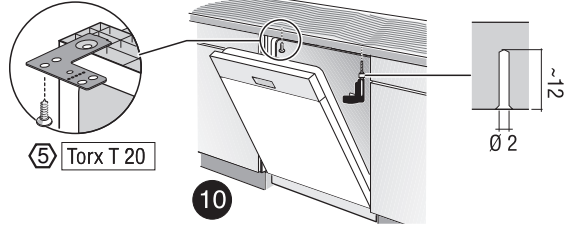

5 Torx T 20

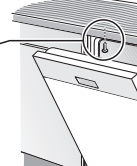

10

Steinplatte
Stone slab
Plaque de pierre
Losa

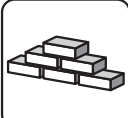

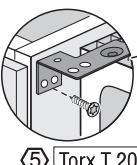

5 Torx T 20

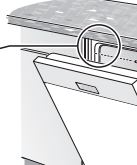

10

6

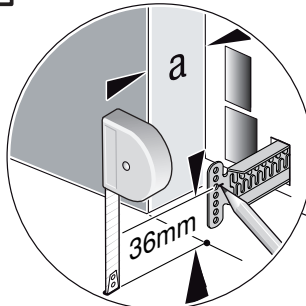

11

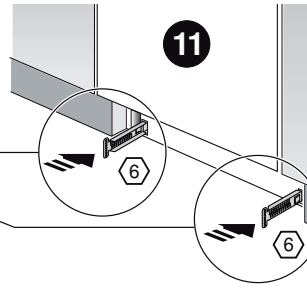

12

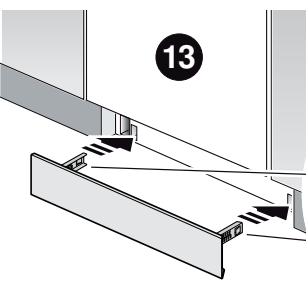

13

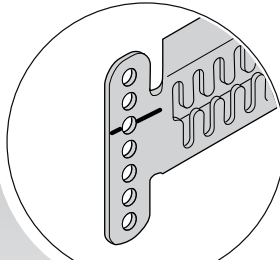
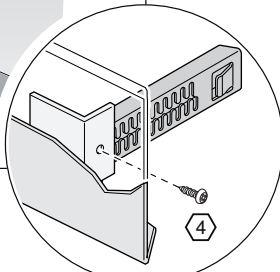

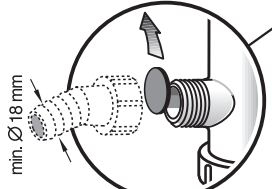

7

Scheibe entfernen
remove disc
enlever le disque
Eliminar disco

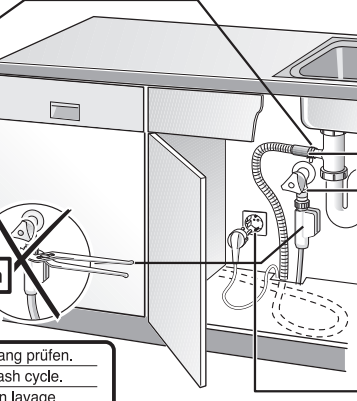

min. Ø 18 mm



max. 10 Nm

14

15

16

min. 10 mm

26,4 mm 20,9 mm
(G 3/4") (G 1/2")

0,05 - 1 MPa
(0,5 - 10 bar)
max. 60°C

DK SE NO FI

17

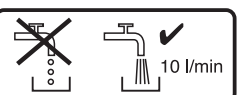

Dichtheit nach einem Spülgang prüfen.
Check for leaks after one wash cycle.
Vérifiez l'étanchéité après un lavage.
Verificar la estanqueidad tras un ciclo de lavado.

10 l/min

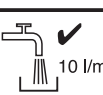









GB

Ø 38 mm

max. 1,1 m

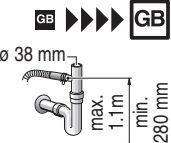
min. 280 mm



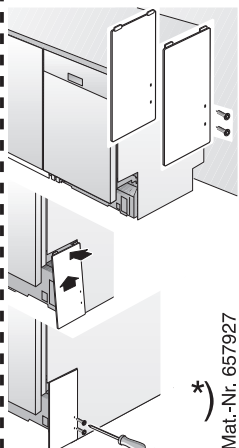

*) Mat.-Nr. 657927

GB

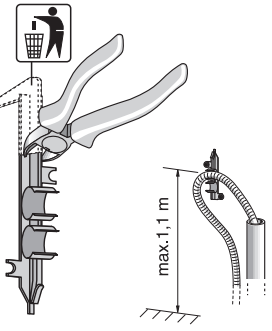

max. 1,1 m

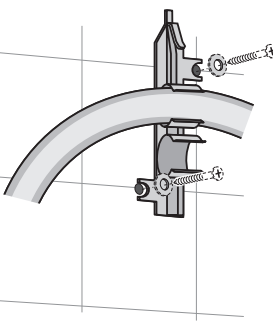

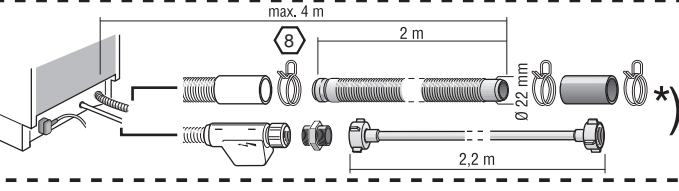

max. 4 m

2 m

Ø 22 mm

2,2 m

*) Mat.-Nr. 350564

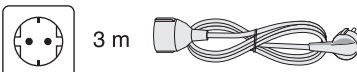

3 m

EU

*) Mat.-Nr. 644533

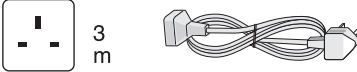

3 m

GB

*) Mat.-Nr. 644534