



Register your new Bosch now:
www.bosch-home.com/welcome



**Electric grill
PKU375CA1.**



BOSCH

en Instruction manual

Table of contents

	Intended use	3
	Important safety information	4
	Causes of damage	5
	Environmental protection	5
	Tips on energy saving	5
	Environmentally-friendly disposal	5
	Getting to know your appliance	6
	Your new lava stone grill	6
	Before using for the first time	6
	Cleaning the appliance	6
	Heating the grill	6
	Operating the appliance	7
	Grilling with water and lava stones	7
	Setting the grill	7
	Preheating the grill	7
	Overheating protection	7
	Adding water	7
	After grilling	8
	Grilling table	8
	Tips and tricks	9
	Cleaning	10
	Do not use these cleaning agents	10
	Cleaning the appliance	10
	Customer service	11
	E number and FD number	11

Additional information on products, accessories, replacement parts and services can be found at www.bosch-home.com and in the online shop www.bosch-eshop.com

Intended use

Read these instructions carefully. Only then will you be able to operate your appliance safely and correctly. Retain the instruction manual and installation instructions for future use or for subsequent owners.

Check the appliance for damage after unpacking it. Do not connect the appliance if it has been damaged in transport.

Only a licensed professional may connect appliances without plugs. Damage caused by incorrect connection is not covered under warranty.

This appliance is intended for private domestic use and the household environment only. The appliance must only be used for the preparation of food and beverages. The cooking process must be supervised. A short cooking process must be supervised without interruption. Only use the appliance in enclosed spaces.

This appliance is intended for use up to a maximum height of 2000 metres above sea level.

Do not use any unsuitable safety devices or child protection grilles. These can cause accidents.

This appliance is not intended for operation with an external clock timer or a remote control.

This appliance may be used by children over the age of 8 years old and by persons with reduced physical, sensory or mental capabilities or by persons with a lack of experience or knowledge if they are supervised or are instructed by a person responsible for their safety how to use the appliance safely and have understood the associated hazards.

Children must not play with, on, or around the appliance. Children must not clean the appliance or carry out general maintenance unless they are at least 8 years old and are being supervised.

Keep children below the age of 8 years old at a safe distance from the appliance and power cable.

Important safety information

This appliance must be installed according to the installation instructions included.

Warning – Risk of fire!

- Hot oil and fat can ignite very quickly. Never leave hot fat or oil unattended. Never use water to put out burning oil or fat. Switch off the hotplate. Extinguish flames carefully using a lid, fire blanket or something similar.
- The appliance becomes very hot and flammable materials could catch fire. Never store or use flammable objects (e.g. spray cans, cleaning agents) under the appliance or in its immediate vicinity. Never place flammable items on or in the appliance.
- The appliance becomes very hot and flammable materials could catch fire. Do not use any charcoal or similar fuels in this appliance.

Warning – Risk of burns!

- The accessible parts become very hot when in operation. Never touch hot parts. Keep children at a safe distance.
- Dripping fat can catch fire quickly during grilling. Do not bend over the appliance. Keep a safe distance away.
- The grill remains hot for a long time after being switched off. Do not touch the grill for 30 - 45 minutes after switching it off.
- When the appliance cover is closed, heat will accumulate. Only close the appliance cover when the appliance has cooled down. Never switch the appliance on with the appliance cover closed. Do not rest food on the appliance cover or use it to keep food warm.

Warning – Risk of electric shock!

- Incorrect repairs are dangerous. Repairs may only be carried out by one of our trained after-sales engineers. If the appliance is faulty, unplug the mains plug or switch off the fuse in the fuse box. Contact the after-sales service.
- The cable insulation on electrical appliances may melt when touching hot parts of the appliance. Never bring electrical appliance cables into contact with hot parts of the appliance.
- Do not use any high-pressure cleaners or steam cleaners, which can result in an electric shock.
- A defective appliance may cause electric shock. Never switch on a defective appliance. Unplug the appliance from the mains or switch off the circuit breaker in the fuse box. Contact the after-sales service.

Causes of damage

Caution!

- **Damage from unsuitable accessories:** only use designated original accessories. Do not use grilling trays or aluminium containers. This will damage the cast grill.
- If hard or sharp objects fall on the glass ceramic panel or the glass ceramic cover, damage could occur.

Environmental protection

In this section, you can find information about saving energy and disposing of the appliance.

Tips on energy saving

- Only heat the appliance until it has reached the desired temperature.
- Switch to a lower grill setting in good time.
- Select the appropriate ongoing grill setting. You will waste energy if you select an ongoing grill setting that is too high.
- Use the residual heat of the grill. For longer cooking times, you can switch off the grill 5-10 minutes before the cooking time ends.

Environmentally-friendly disposal

Dispose of packaging in an environmentally-friendly manner.



This appliance is labelled in accordance with European Directive 2012/19/EU concerning used electrical and electronic appliances (waste electrical and electronic equipment - WEEE). The guideline determines the framework for the return and recycling of used appliances as applicable throughout the EU.

Getting to know your appliance

In this section, we will explain the components and controls.

Your new lava stone grill

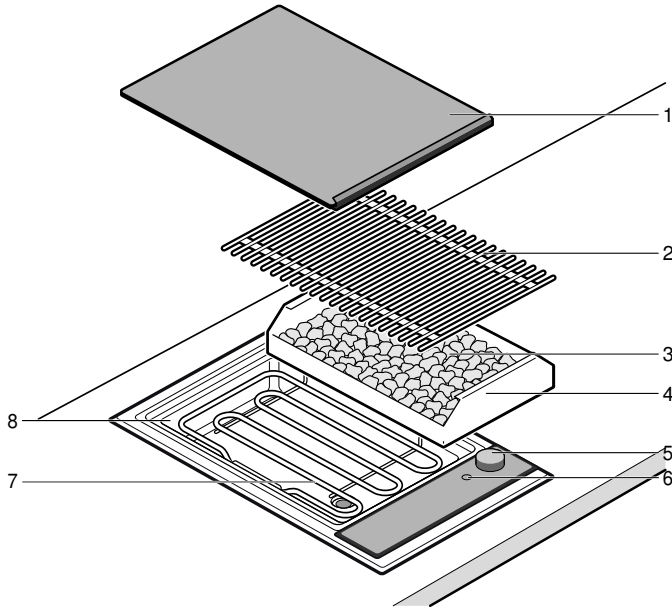

No.	Name
1	Glass ceramic cover
2	Wire rack
3	Lava stones
4	Lava stone container
5	Dial
6	Indicator light
7	Grill element
8	Grill container (water bath)

Before using for the first time

In this section, you can find out what you must do before using your appliance to prepare food for the first time. Read the safety information before you start. → *"Important safety information" on page 4*

Cleaning the appliance

Before using the appliance and accessory parts for the first time, clean them thoroughly with lukewarm soapy water.

Heating the grill

Heat the empty grill for a few minutes at the highest setting. This will eliminate the new odour. A slight development of smoke is normal when the grill is used for the first time.

Operating the appliance

In this section, you can find out how to set your appliance. In the table, you can find the settings for various dishes.

Grilling with water and lava stones

Note: Fill the grill container with water before each use. Otherwise the appliance will overheat.

The amount of water depends on whether you want to use lava stones. The lava stones store the heat from the grill element, leading to intense radiation of heat and even heat distribution.

Filling with water and lava stones

1. Remove the wire rack and fold up the grill elements. Remove the lava stone container from the appliance.
2. Ensure the drain valve is closed.
3. Fill the grill's container with water.
Grilling with lava stones: 0.7 litres (bottom mark)
Grilling without lava stones: 2.5 litres (top mark)

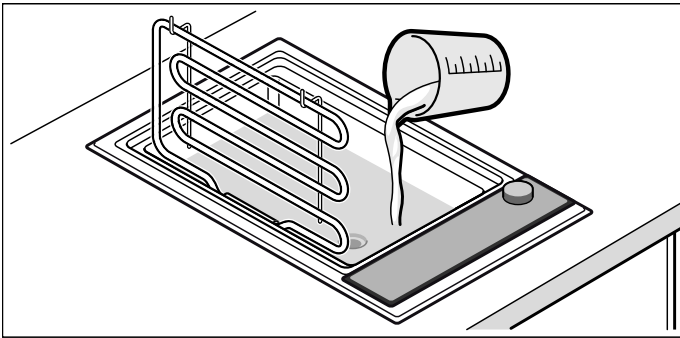

4. To grill with lava stones: Remove the lava stones from the packaging and place them in the lava stone container. Insert the lava stone container in the appliance.

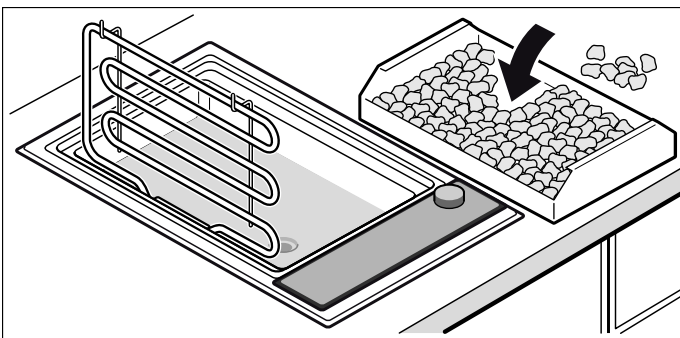

5. Fold down the grill heating element, replace the wire rack. The grill is ready to use.

Setting the grill

The dial allows you to adjust the grill's heat setting. The dial has no increments – the heat setting is infinitely variable. The indicator light will light up when the grill has been switched on.

Turn the dial to 0 to switch off the appliance.

Note: The grill regulates the temperature by switching the grill element on and off. The grill element may also switch on and off at the highest setting.

Preheating the grill

Do not place the food to be grilled under the grill until the preheating time has elapsed. Use the information provided in the grill table to guide you. Always preheat the grill at setting 9.

Preheating takes between 8 and 12 minutes.

Note: Preheat the grill without food under it for no longer than 8-12 minutes. Leaving the grill to heat up for prolonged periods of time may cause the appliance to shut down (overheating protection). Switch off the appliance and allow it to cool down before switching it back on again.

Overheating protection

The overheating protection switches the grill heating off when the grill overheats. When the grill has cooled down sufficiently, grill heating switches on again automatically.

Adding water

Warning – Risk of scalding!

If water touches the hot wire grilling rack or grill element during topping up, hot steam will be generated. Do not reach over the grill while topping up and do not pour water over the hot components.

If there is not enough water in the grill pan, the overheating protection shuts down the appliance. It is therefore important that you keep an eye on the amount of water in the grill pan, and that you add more water if required.

Note: To add more water, there is no need to remove the wire rack or to fold up the grill element. Before adding more water, allow the grill to cool down sufficiently.

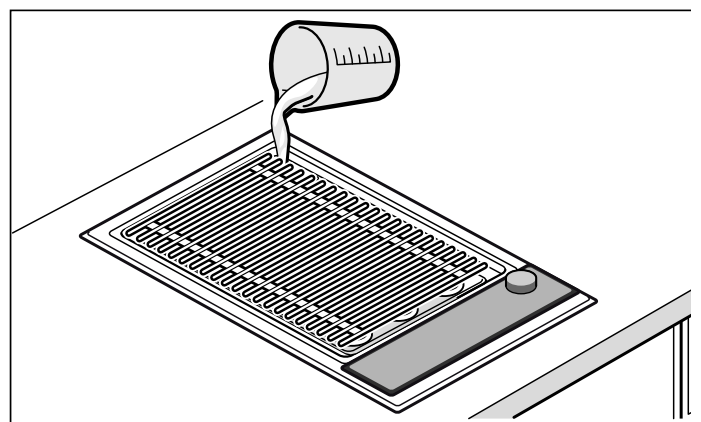

Grilling with or without lava stones: 0.7 litres

After grilling

Only close the glass ceramic cover after the grill has cooled down completely. Leave damp lava stones to dry completely before you close the glass ceramic cover or else mould could develop.

If the water is still hot when being drained, first add cold water to cool it down! To drain the water, place a heat-resistant container underneath the drain tap. Open the tap by turning the lever 90° downwards. Then close the tap by turning the lever upwards to the stop.

Grilling table

The values in the tables are given as a guide and are based on a pre-heated grill. The values may vary depending on the type and amount of food to be grilled.

Do not place the food to be grilled onto the grill until the pre-heating time has elapsed.

Turn the grilled food at least once.

Grilled food	Preheating time (in minutes) at setting 9	Grill setting over lava stones	Grill setting over water bath	Grilling time in minutes	Information
Beefsteak, medium, 2-3 cm	12	8 - 9	8 - 9	8 - 10	
T-bone steak, medium rare, 3 cm	10	7 - 8	8 - 9	10 - 15	
Pork neck steak, boned	10	8 - 9	8 - 9	12 - 16	
Pork chops, 2 cm	8	7 - 8	8 - 9	15 - 20	Cut along the bone
Lamb chops, medium rare, 2 cm	10	7 - 8	8 - 9	8 - 12	
Chicken breast, 2 cm	10	7 - 8	8 - 9	15 - 20	
Chicken wings, 100 g each	10	7 - 8	8 - 9	15 - 20	
Turkey escalope, without breadcrumbs, 2 cm	10	7 - 8	8 - 9	12 - 15	
Salmon steak, 3 cm	8	7 - 8	8 - 9	20 - 25	Oil the wire rack
Tuna steak, 2 cm	8	7 - 8	8 - 9	10 - 15	Oil the wire rack
Trout, whole, 200 g	10	7 - 8	8 - 9	12 - 15	Oil the skin well; repeat before turning
King prawns, 30 g each	10	7 - 8	8 - 9	12 - 15	
Hamburgers/meatballs, 1 cm	10	7 - 8	8 - 9	12 - 17	
Kebab skewers, 100 g each	8	7 - 8	8 - 9	17 - 25	Turn frequently
Grilled sausage, 100 g each	10	7 - 8	8 - 9	10 - 20	
Vegetables	8	7 - 8	8 - 9	8 - 12	For example, aubergines, courgettes in slices 1 cm thick, peppers in quarters

Tips and tricks

- Always pre-heat the grill. That way, the intense heat radiation causes a crust to form quickly and prevents meat juice from escaping.
- Before grilling, you can coat or marinate the food in heat-resistant oil (e.g. peanut oil). This improves the flavour. Be careful not to use too much oil/marinade, otherwise this could cause flames to form or generate lots of smoke.
- Do not salt the meat before grilling. Otherwise soluble nutrients and meat juice may escape.
- Place the food to be grilled directly on the wire rack. Do not use any aluminium foil or grilling trays.
- Only turn the items on the grill over when they lift off the wire rack easily. If meat sticks to the grill, the fibres are destroyed and meat juice escapes.
- Do not pierce the meat while grilling it, otherwise meat juice may escape.
- Cured meat such as ham and smoked pork chops are not suitable for grilling. This can produce a compound that is harmful to health.
- Score chops on the bones and in fatty layers several times so that they do not curl up.
- Remove fatty layers after grilling instead of before, otherwise the meat loses juice and flavour.
- Poultry will turn out particularly crispy and brown if you baste it towards the end of the grilling time with butter, salted water or orange juice.
- Fruit can be seasoned to taste after grilling with honey, maple syrup or lemon juice.
- You can parboil vegetables that take a long time to cook (e.g. corn on the cob) before placing them on the grill.
- Grill fillets of fish on the skin side first. Coat the skin with oil, so that it does not stick to the wire rack.
- Serve grilled food hot. If you keep it warm it will go tough.
- Drops of fat falling onto the heating element may ignite and briefly produce flames and smoke. Very fatty foods should be grilled over the water bath to minimise this.

Cleaning

With good care and cleaning, your appliance will retain its appearance and remain fully functioning for a long time to come. We will explain here how you should correctly care for and clean your appliance.

Suitable maintenance and cleaning products can be purchased from the after-sales service or in our e-Shop.

Warning – Risk of burns!

The appliance becomes hot during operation. Allow the appliance to cool down before cleaning.

Warning – Risk of electric shock!

Do not use any high-pressure cleaners or steam cleaners, which can result in an electric shock.

Warning – Risk of burns!

The accessible parts become very hot when in operation. Never touch hot parts. Keep children at a safe distance.

Do not use these cleaning agents

- Scouring or chemically aggressive cleaners
- Acidic cleaners (e.g. vinegar, citric acid, etc)
- Cleaners containing chlorine or with a high content of alcohol
- Oven cleaner
- Hard and scratchy sponges, brushes or scouring pads
- Thoroughly wash out new sponge cloths before using them.

Cleaning the appliance

Leave the appliance to cool and clean after each use. This will prevent residues from being burnt on. Residues that have been burnt-on several times can only be removed with difficulty.

1. Allow the appliance to cool down.
2. Remove the wire rack.
3. Swing the heating element upwards.
4. Remove the lava stone trough and lava stones.
5. Leave burnt-on residues to soak in water and washing-up liquid.

Note: Do not scrape off burnt-on residues.

Appliance part/surface	Recommended cleaning
Wire rack	Remove large clumps of residue using a scrubbing brush. Soak the wire rack in the sink. Clean using a scrubbing brush and washing-up liquid and dry thoroughly. Apply our grill cleaner gel (order no. 00311761) to stubborn dirt and let it work for at least 2 hours, or overnight for heavy soiling. Then rinse off thoroughly and dry. Follow the instructions on the cleaner's packaging. Note: Do not clean them in the dishwasher.
Lava stone trough and grill container	Remove the lava stones and drain the water. Clean in a sink of water and washing-up liquid using a scrubbing brush; dry with a soft cloth. Soak stubborn dirt or apply our grill cleaner gel (order no. 00311761) to it to remove it.
Lava stones	Occasionally dry out very damp lava stones in the oven at 200 °C. This will prevent the formation of any mildew. Replace the lava stones when they have turned black. This means that the lava stones are saturated with fat, which may generate a lot of smoke during operation, or the fat may ignite. You can obtain replacement lava stones from your specialist dealer (order number 00291050). Take care when refilling that the grill element is not resting directly on the lava stones.
Control panel and glass ceramic cover	Clean using a soft, damp cloth and some washing-up liquid; the cloth must not be too wet. Dry with a soft cloth.

 **Customer service**

Our after-sales service is there for you if your appliance needs to be repaired. We will always find an appropriate solution, also in order to avoid after-sales personnel having to make unnecessary visits.

E number and FD number

Please quote the E-number (product number) and the FD number (production number) of your appliance when contacting the after-sales service. The rating plate bearing these numbers can be found on the appliance certificate.

Please note that a visit from an after-sales service engineer is not free of charge in the event of misuse of the appliance, even during the warranty period.

Please find the contact data of all countries in the enclosed customer service list.

To book an engineer visit and product advice

GB 0344 892 8979

Calls charged at local or mobile rate.

IE 01450 2655

0.03 € per minute at peak. Off peak 0.0088 € per minute.

Rely on the professionalism of the manufacturer. You can therefore be sure that the repair is carried out by trained service technicians who carry original spare parts for your appliances.



Robert Bosch Hausgeräte GmbH

Carl-Wery-Straße 34
81739 München, GERMANY

www.bosch-home.com



9001240762
950526