

5

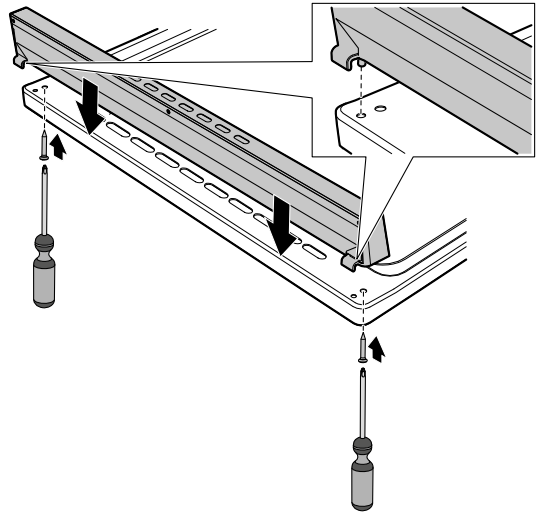

6

a

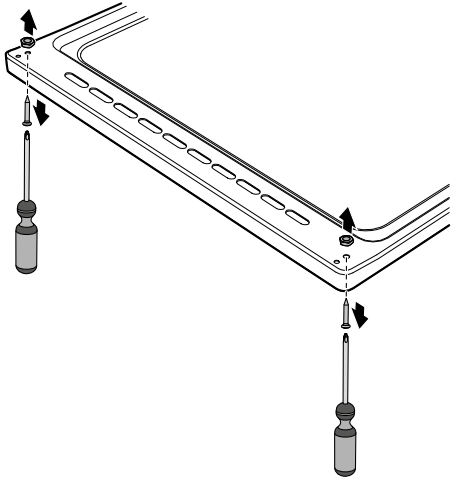
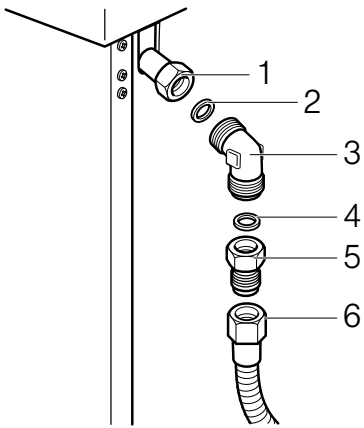

b

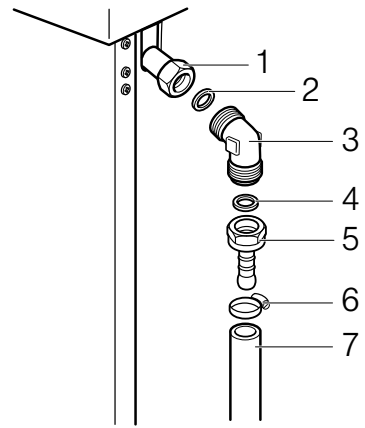

7

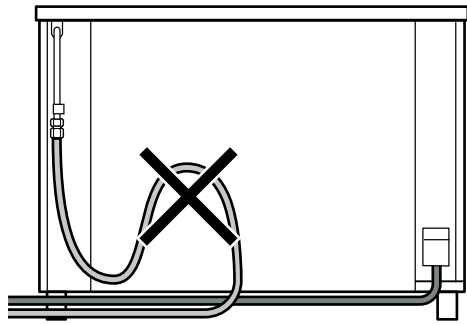
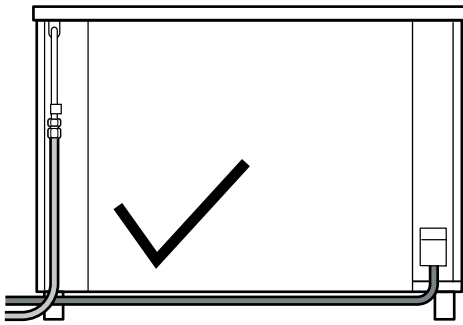

**8a**

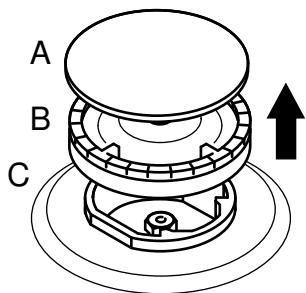

**b**

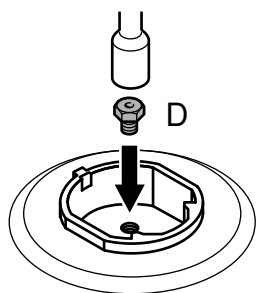

**c**

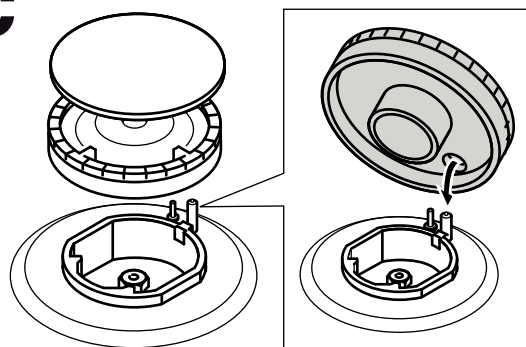

**9**

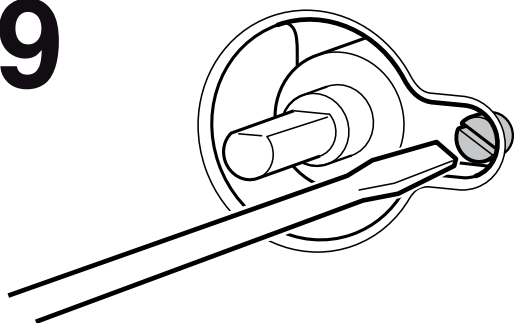

**10**

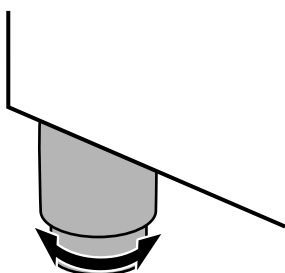

## Safety precautions

Read and store these instructions carefully. Safe use can only be guaranteed if the appliance has been installed by a professional and in accordance with these assembly instructions.

The appliance must be connected to the mains only by a licensed and trained technician.

If you wish to convert to a different type of gas, call the after-sales service.

### ⚠ Risk of gas escape!

After connecting the appliance to the gas supply, always check the connection for leak tightness. The manufacturer accepts no responsibility for the escape of gas from a gas connection which has been previously tampered with.

The fitter or the installer is liable for damage or faults resulting from incorrect assembly or installation.

When installing the appliance you must observe the building regulations that are currently applicable and the regulations set by the local electricity and gas suppliers (e.g. Germany: DVGW-TRGI/TRGF; Austria: ÖVGW-TR).

Switch off the power and gas supply before carrying out any work.

The information on the rating plate regarding voltage, gas type and gas pressure must comply with the local connection conditions.

Electrical appliances must always be earthed.

If an extractor hood is to be fitted, it must be fitted according to the associated assembly instructions. Take into consideration the specified minimum distance to the hob.

This appliance must not be installed on boats or in vehicles.

### ⚠ Gas-pressure regulator!

This appliance requires an operating pressure of 2,8 kPa at the appliance. A suitable LPG regulator that complies with the requirements of SANS 1237 must be installed.

### ⚠ Important Information for the user!

This appliance may only be installed by a registered LP Gas installer. All registered installers are issued with a card carrying their registration number. Ask to be shown the card before allowing the installation work to commence and make a note of the Installer QCC number. Upon completion of the installation, the installer is required to explain the operational details of the appliance together with the safety instructions. You will be asked to sign acceptance of the installation and be provided with a completion certificate. You should only sign for acceptance of the installation when the installation is completed to your satisfaction.

Note that your invoice is required in the event that you wish make a guarantee claim.

### ⚠ Important Information for the installer!

This appliance may only be installed by a LP gas installer registered with the Liquefied Petroleum Gas Association of Southern Africa. The appliance must be installed in accordance with the requirements of SANS 10087-1 and any fire department regulations and/or local bylaws applicable to the area. If in doubt check with the relevant authority before undertaking the installation. Upon completion of the installation you are required to fully explain and demonstrate to the user the operational details and safety practices applicable to the appliance and the installation.

## Before installing

These instructions are intended for several models. Details may vary, depending on the appliance model.

Read the following information about the appliance and the guidelines for ventilation.

In this section, you will find information on

- Unpacking
- the appliance classes
- the appliance dimensions
- the distance from any adjacent furniture
- the rating plate

### Unpacking

Check the appliance for damage after unpacking it. Do not connect the appliance if it has been damaged in transport. Dispose of packaging in an environmentally-friendly manner.

## Appliance classes - Fig. 1

This appliance corresponds to the following appliance classes:

Appliance class	Description
<b>Fig. 1a</b>	<b>Class 1</b> Non flush-fitted cooker
<b>Fig. 1b</b>	<b>Class 2 - subclass 1</b> Cooker immediately adjacent to two units, consisting of a single unit, can also be installed so that the side walls are accessible

## Appliance dimensions - Fig. 2

### Adjacent units - Fig. 3

Adjacent units and adjacent unit fronts must be heat-resistant up to at least 90 °C. If the appliance is installed close to other kitchen units, you must comply with the minimum distances specified in the diagram.

### Rating plate

The technical data for the appliance can be found on the rating plate.

The rating plate is on the back of the appliance.

The setting values are specified on a label on the appliance packaging.

Enter the product number (E no.), production number (FD no.), factory settings for the type of gas/gas pressure and, if applicable, the converted gas type into the table below. The changes made to the appliance and the type of connection are crucial for the safe and correct operation of the appliance.

E no.	FD no.
Aftersales service 	
Type of gas/gas pressure Factory setting	_____
Type of gas/gas pressure Conversion	_____

## Guidelines for ventilation

This appliance must only be installed in a room that is sufficiently ventilated.

If the total power for all gas appliances is below 11 kW, then this requirement is met if the installation room has a volume of over 15 m<sup>3</sup> and at least one door leading outside or one window that can be opened.

If the total power for all gas appliances is above 11 kW, then this requirement is met if the installation room has a volume of over 2 m<sup>3</sup> per kW and at least one door leading outside or one window that can be opened. Furthermore, an exhaust extractor hood or a controlled domestic ventilation system (no recirculated air operation) should be present and should have a minimum flow volume of 15 m<sup>3</sup>/h for each kW of total power for all gas appliances. Appropriate supply air openings must be present.

**Note:** In some countries, the requirements for minimum room volume vary. Find out information on this from your after-sales service.

## Installation

This appliance is supplied with a set of adjustable feet and a glass cover. The glass cover is prefitted.

### Fitting the adjustable feet - Fig. 4

1. Remove all parts that are not permanently fixed, especially the pan supports and burners.
2. Remove the accessories from the oven.
3. Tilt the appliance by raising it slightly on one side from the floor.
4. Screw the adjustable feet into the mounting holes on the underside of the appliance.

**Note:** If you then need to pull the appliance, screw in the adjustable feet fully.

5. Only finally level the appliance when the electricity and gas have been connected, and all of the installation work has been completed.

### Fitting the splash guard - Fig. 5

1. Remove the packaging and the protective film from the splash guard.
2. Loosen the two screws on the back of the appliance.  
The nuts are no longer required.
3. Place the splash guard into the holes intended for this purpose using the dowels.
4. Insert and tighten the bolts from below.

### Electrical connection

The appliance must only be connected to the power supply by a licensed professional. The appliance must be installed in accordance with the most recent IEE guidelines (Institute of Electrical Engineers). The appliance may be damaged if incorrectly connected.

Make sure the voltage of the power supply corresponds to the specified value on the rating plate.

Ensure that the power supply is properly earthed and that the fuse and the wiring and piping system in the building is sufficiently dimensioned for the electrical power of the appliance.

It is recommended that you configure the circuit for the appliance to 16 A.

Observe the following points when routing the service cable:

- Do not pinch or squeeze the cable.
- Keep the cable away from sharp edges.
- Do not bring the cable into contact with parts that can reach temperatures of more than 50 °C above room temperature.

### Connecting the appliance to the power supply

The appliance corresponds to protection class 1 and may only be operated with a protective earth connection.

The appliance must be disconnected from the power supply for all installation work.

The appliance must only be connected to the power supply with the power cable provided.

Contact protection must be ensured by the installation.

Only a licensed expert may connect the appliance. He is subject to the regulations of the local electricity provider.

Power cable without a plug with earthing contact

An all-pole isolating switch with at least a 3 mm contact gap must be fitted in the installation. Identify the phase and neutral conductors in the socket. The appliance may be damaged if incorrectly connected.

Connection to nominal voltage 220-240 V. Connect the wires of the mains power cord according to the colour coding: green/yellow = PE conductor (⊕), blue = (zero) neutral conductor, brown = phase (external conductor).

### Gas connection

The appliance must be connected in accordance with the currently applicable regulations. Before installing the appliance, check that the local conditions (type of gas and pressure) are compatible with the appliance settings. The permissible appliance settings can be found on the rating plate. The appliance must be connected to the gas lines and seals by a professional in accordance with currently applicable standards.

#### Gas connection on the appliance

The gas connection is located on the rear of the appliance.

A connection elbow (EN ISO 228 G1/2 male - 228 G1/2 male), an adapter for natural gas (EN ISO 228 G1/2 - EN 10226 R1/2), and a hose connection for liquefied gas (EN ISO 228 G1/2 - LPG) are supplied with the appliance.

#### Default setting of the burners

The burners have been preset for liquefied gas G30/31 (28-30/37 mbar). A nozzle set for G20 natural gas (20 mbar) is supplied with the appliance.

### Connecting to natural gas - Fig. 6a

Only use connecting cables or flexible hoses which comply with the applicable regulations and which are approved for this purpose.

1. Screw the elbow (3) and the seal (2) to the gas connection (1)
2. Hold the elbow (3) in place with a spanner and screw the adapter piece (5) and the seal (4) to the elbow.
3. Hold the adapter piece (5) with a spanner and screw it to a fixed connection line or a flexible gas connecting hose (6).

Only use approved sealing compound to seal the thread.

### Connecting to liquefied gas - Fig. 6b

If you connect the appliance to liquefied gas, you must always install a suitable gas pressure regulator. Use the total gas consumption of the appliance stated on the rating plate to select a suitable gas pressure regulator.

Only use connecting cables or flexible hoses which comply with the applicable regulations and which are approved for this purpose.

1. Screw the elbow (3) and the seal (2) to the gas connection (1)
2. Screw the hose connection (5) and the seal (4) to the elbow (3).
3. Slide the flexible gas connecting hose (7) onto the hose connection (5).

4. Pull the clamp (6) tight.

Only use approved sealing compound to seal the thread.

### Flexible hoses - Fig. 7

For flexible hoses, observe the following points:

- Do not pinch or squeeze hoses.
- Do not subject the hoses to twisting or pulling forces.
- Keep the hoses away from sharp edges.
- Do not let the hoses come into contact with parts that may reach a temperature higher than 70 °C above room temperature.
- Make sure that the full length of the hoses is accessible for inspection.

### Installing the safety valve

The installation of a safety valve for opening and closing the gas supply is a compulsory requirement. Fit the safety valve between the gas supply line to the appropriate room and the appliance. Ensure unhindered access to this valve.

### Checking for leaks

After connecting the gas line, check the connections for leaks using soapy water.

### Initial use

Switch the appliance on as described in the instructions for use. Light all the burners and check that the flames remain stable at both the high and low settings.

### Converting the gas type

If the appliance is not already set up for the existing type of gas, the appliance must be converted. The conversion to a different type of gas must be carried out by an authorised expert in accordance with the applicable regulations. The type of gas and pressure that was preset at the factory are indicated on the rating plate.

In order to convert to a different type of gas, the nozzles must be replaced and the low flame and primary air may have to be adjusted.

### Replacing the gas burner nozzles - Fig. 8

1. Disconnect the appliance from the electricity supply.
2. Remove the pan support.
3. Remove the burner cap **A** and burner cup **B** from the burner **C** (Fig. 8a).
4. Remove the nozzle **D** and replace it with an appropriate nozzle for the new type of gas (Fig. 8b).
5. Replace the old gas label with the new gas label.  
The new gas label is supplied with the nozzle set.
6. Place the burner cup **B** onto the burner **C**.
7. Position the burner cap **A** exactly on top of the burner cup **B** (Fig. 8c).
8. Refit the pan support.

### Setting the minimum gas flow

1. Disconnect the appliance from the power supply.
2. Switch on the gas burner and light the gas with a match.
3. Turn the control knob for the gas burner towards the small flame setting.
4. Detach all of the control knobs.
5. Undo the screws and remove the control panel (fig. 9a).
6. Adjust the internal setting screw until a stable flame is burning correctly (fig. 9b).
7. Loosen the setting screw to increase the gas flow or tighten it to decrease the gas flow.

**Note:** Make sure that the flame does not go out when the gas flow is quickly changed between maximum and minimum, and vice versa.

The setting is correct when the height of the small flame is approx. 3 to 4 mm.

8. Fit the control panel and screw it firmly in place.
9. Refit the control knobs for the gas burner.
10. Connect the appliance.

### General nozzle table

Type of gas	mbar	kPa	Nozzle		Type of burner	Power W	Power min. (W)	Max. consumption		
			Number	Bypass				G20	G30	G31
Natural gas - NG G20	20	2.0	115 (Y)	Gap	High output burner	3000	800	283 l/h		
			97 (Z)	Gap	Standard burner	1800	500	167 l/h		
			72 (X)	Gap	Economy burner	1000	400	97 l/h		
			135 (s)	Gap	Wok burner	3900	1600	359 l/h		
Liquefied gas - LPG Butane Propane G30/G31	28-30/37	2.8-3.0/3.7	85	0.45	High output burner	3000	800	218 g/h		
			65	0.33	Standard burner	1800	500	131 g/h		
			50	0.30	Economy burner	1000	400	73 g/h		
			100	0.63	Wok burner	3900	1600	284 g/h		

### Nominal operating pressure

The nominal operating pressure of your appliance is:

- for natural gas - NG (G20) 20 mbar / 2.0 kPa.
- for liquefied gas - LPG (G30) 30 mbar / 3.0 kPa.
- for liquefied gas - LPG (G31) 37 mbar / 3.7 kPa.

Your appliance must be operated at these pressure values. All information on the rating plate refers to these pressure values. The manufacturer does not accept any liability for operability, power of the appliance or for other risks if the appliance is operated at pressure values other than those values specified for the appliance.

**Note:** If you are operating the appliance with liquefied gas, use a gas pressure regulator. The pressure regulator must be connected and maintained by a licensed technician.

### Positioning and levelling

#### Positioning the appliance

When installing the appliance, make sure that there is enough space in the final installation location to pull the appliance forwards for cleaning and maintenance work.

The ground underneath must be hard and firm. The wall immediately behind the appliance must be made from non-flammable material, e.g. tiles.

If you need to move the appliance in order to position it, make sure that the adjustable feet are fully screwed in.

#### Adjusting the appliance - Fig. 10

Turn the adjustable feet to level the appliance.

**Note:** Only level the appliance once all other work has been completed.



