



MUM52..AU
MUM54..AU
MUM56..AU



BOSCH

en Operating instructions

*Congratulations on the purchase of your new BOSCH appliance.
In doing so, you have opted for a modern, high-quality domestic appliance.
You can find further information about our products on our web page.*

Contents

For your safety	2
Overview	5
Operating the appliance	6
Cleaning and servicing	9
Storage	10
Troubleshooting	10
Application examples	10
Disposal	12
Warranty conditions	12
Optional accessories	12

For your safety

Before use, read these instructions carefully in order to become familiar with important safety and operating instructions for this appliance.

If the instructions for correct use of the appliance are not observed, the manufacturer's liability for any resulting damage will be excluded. This appliance is designed for processing normal household quantities in the home or similar quantities in non-industrial applications.

Non-industrial applications include e.g. use in employee kitchens in shops, offices, agricultural and other commercial businesses, as well as use by guests in boarding houses, small hotels and similar dwellings.

Use the appliance for processing normal quantities of food for domestic use. Do not exceed permitted maximum quantities (see "Application examples").

This appliance is suitable for mixing, kneading and beating food. It must not be used for processing other objects or substances. Other applications are possible if the accessories approved by the manufacturer are used.

Use the appliance with original accessories only. When using the accessories, follow the enclosed operating instructions.

Please keep the operating instructions in a safe place. If passing on the appliance to a third party, always include the operating instructions.

General safety instructions

Electric shock risk

The appliance must not be used by children.

The appliance and its power cord must be kept away from children.

Appliances can be used by persons with reduced physical, sensory or mental capabilities or lack of experience and knowledge if they have been given supervision or instruction concerning use of the appliance in a safe way and if they understand the hazards involved.

Children shall not play with the appliance. Do not leave the running appliance unattended.

Connect and operate the appliance only in accordance with the specifications on the rating plate. Only use indoors. Do not use the appliance if the power cord and/or appliance are damaged. Always disconnect the appliance from the supply if it is left unattended and before assembling, disassembling or cleaning. Do not place the power cord over sharp edges or hot surfaces. To prevent injury, a damaged power cord must be replaced by the manufacturer or his customer service or a similarly qualified person. Only our customer service may repair the appliance.

Safety instructions for this appliance

Risk of injury

Risk of electric shock!

Do not insert mains plug until all preparations for working with the appliance are complete.

Never immerse the base unit in liquid or hold under running water.

Do not use a steam cleaner.

Do not adjust the swivel arm while the appliance is switched on.

Wait until the drive has come to a standstill.

Do not change tool/accessory until the drive is at a standstill – when the appliance is switched off, the drive continues running briefly.

Use only the rotary switch to switch the appliance on or off.

When the appliance is not in use, pull out the mains plug.

Before eliminating a fault, pull out the mains plug.

Risk of injury from the rotating tools!

Keep hands clear of rotating parts. While the appliance is operating, never place fingers in the mixing bowl. Attach the cover (12) before operating the appliance!

Do not change tools until the drive has come to a standstill – when the appliance is switched off, the drive continues running briefly and stops in the tool change position. Do not move the swivel arm until the tool has come to a standstill.

For reasons of safety the appliance cannot be operated unless unused drives are covered with drive guards (5, 8).

Before attaching/removing the continuous-feed shredder, wait until the drive has come to a standstill and pull out the mains plug. Do not reach into the feed tube.

Risk of injury from sharp blades!

Do not grip the sharp blades or edges of the cutting discs. Take hold of cutting discs by the edge only.

Do not touch blender blades with bare hands.

Risk of injury from sharp blades/rotating drive!

Never place fingers in the attached blender! Do not remove/attach the blender until the drive is at a standstill! Operate the assembled blender only and with the lid attached.

Risk of scalding!

If processing hot liquids, steam escapes through the funnel in the lid. Add a max. 0.5 litres of hot or frothing liquid.

Important!

Use the appliance with original accessories only. When using the accessories, follow the enclosed operating instructions.

Use only one tool or accessory at any one time.

▲ Explanation of the symbols on the appliance or accessory



Follow the instructions in the operating instructions.



Caution! Rotating blades.



Caution! Rotating tools.

Do not place fingers in the feed tube.

Safety systems

Start lock-out

See “Operating positions” table.

The appliance can be switched on in **pos. 1 and 3** only:

- when the bowl (11) has been inserted and turned until it locks into place and
- the blender drive cover has been attached (9).

Restart lock-out

If the power is interrupted, the appliance remains switched on but the motor does not start running again when the power is restored. To switch the appliance on again, turn the rotary switch to **0/off**, then switch on.

Overload protection

If the motor switches itself off while the appliance is being used, the overload protection feature has been activated. A possible cause may be that too much food was processed at one time.

If a safety system is activated, see “Troubleshooting”.

The operating instructions describe several models, see also overview of models (Fig. M). The appliance requires no maintenance.

Overview

Please fold out the illustrated pages. Fig. A

Base unit

1 Release button

2 Swivel arm

“Easy Armlift” function to support the upward movement of the arm (see “Work positions”).

3 Rotary switch

When the appliance has been switched off (position **0/off**), the appliance runs automatically to the optimum position for changing the tools.

MUM52..:

0/off = Stop

M = Pulse switch at maximum speed, grip switch for required blending duration.

Settings **1–4**, Operating speed:

1 = low speed – slow,

4 = high speed – fast.

MUM54../MUM56..:

0/off = Stop

M = Pulse switch at maximum speed, grip switch for required blending duration.

Settings **1–7**, Operating speed:

1 = low speed – slow,

7 = high speed – fast.

4 On/Off display (MUM54../56..)

Is lit while the appliance is operating (rotary switch on **M** or **1–7**).

Flashes if the appliance has been operated incorrectly, the electronic fuse has tripped or the appliance is defective – see section entitled “Troubleshooting”.

5 Drive for

– continuous-feed shredder and
– citrus press (special accessory *).

When not in use, attach the drive cover.

6 Drive cover

To remove the drive cover, press on the rear area and remove cover.

7 Drive for tools (stirrer, whisk, kneading hook) and mincer (special accessory *)

8 Drive for blender (special accessory *)

When not in use, attach the blender drive cover.

9 Blender drive cover

10 Cord store

MUM52../MUM54..: Stow the cord in the cord store.

MUM56..: Automatic cord winder

Bowl with accessories

11 Stainless steel stirring bowl

12 Lid

Tools

13 Stirrer

14 Whisk

15 Kneading hook with dough deflector

16 Accessories bag

For storage of the tools and cutting discs.

Continuous-feed shredder

17 Pusher

18 Cover with filling shaft

19 Cutting discs

19a Reversible slicing disc – thick/thin

19b Reversible shredding disc – coarse/fine

19c Grating disc – medium-fine

20 Drive shaft

21 Housing with outlet opening

Blender *

22 Blender jug

23 Lid

24 Funnel

* If an accessory is not included in the product package, it can be purchased via the trade or customer service.

Operating positions

Fig. B

Attention!

Before operating the appliance, attach the tool/accessory to the correct drive and in the correct position and place in the operating position according to this table.

The swivel arm must be engaged in every operating position.











Note

The swivel arm features an “Easy Armlift” function which supports the upwards movement of the swivel arm.

Selecting the operating position:

- Press the Release button and move the swivel arm.
Support movement with your hand.
- Move the swivel arm until it engages in the required position.

Position	Drive		MUM52..	MUM54.. MUM56..
1	7		1-4	1-7
			1-4	1-7
			1-2	1-3
2	7		*	-
3	5		2-4	3-7
			2-3	3-5
4	8		3-4	5-7
	7		3-4	5-7

* Insert/remove whisk, stirrer or kneading hook. Add large quantities of ingredients.

Operating the appliance



Risk of injury!

Do not insert mains plug until all preparations for working with the appliance are complete.

Attention!

*Do not operate the appliance without an accessory/tool in the operating position.
Do not operate the appliance empty.
Do not expose appliance or accessories to heat sources. Parts are not microwave-safe.*

- Before operating the appliance and accessories for the first time, clean thoroughly; see "Cleaning and servicing".



Important information

In these instructions for use the recommended reference values for the operating speed refer to appliances with a 7-setting rotary switch. For appliances with a 4-setting rotary switch you can find the values in brackets after the values for a 7-setting rotary switch.

These instructions for use contain a sticker with reference values for the operating speed of the appliance when using the tools or accessories. We recommend attaching this sticker to the appliance (Fig. 9).

Preparation

- Place the base unit on a smooth, clean surface.
- Pull out the power cord (Fig. 10).

MUM52../MUM54..

Cord store:
Pull out cable to the required length.

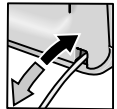

MUM56..

Automatic cord winder:
Pull out the cord in one go to the required length (max. 100 cm) and slowly release; the cord is locked.

Reducing the cord length:

Pull gently on the cord and allow it to roll up to the required length. Then gently pull the cord again and slowly release; the cable is locked.



Warning!

*Do not twist the cord when inserting it.
If the appliance features an automatic cord winder, do not insert the cord manually.
If the cord jams, pull out the cord all the way and then allow it to wind up.*

- Insert the mains plug.

Bowl and tools



Risk of injury from rotating tools

While the appliance is operating, keep fingers clear of the mixing bowl. Attach the cover (12) before operating the appliance!

Do not change tools until the drive has come to a standstill – when the appliance is switched off, the drive continues running briefly and stops in the tool change position. Do not move the swivel arm until the tool has come to a standstill.

For reasons of safety the appliance may only be operated when unused drives have been covered with drive guards (6, 9).

Attention!

Use bowl with this appliance only.

Stirrer (13)

for stirring dough, e.g. cake mixture



Whisk (14)

for whisking egg whites, cream and light dough, e.g. sponge mixture



Kneading hook (15)

for kneading heavy dough and mixing-in ingredients that ought not be cut (e.g. raisins and chocolate chips)



Working with the bowl and the tools

Fig. 13

- Press the Release button and move the swivel arm to position 2.
- Insert the bowl:
 - Tilt the bowl forwards and then set it down,
 - turn anti-clockwise until it locks into place.
- Depending on the processing task, insert the stirrer, whisk or kneading hook until it locks into position.



Note:

If using the kneading hook, rotate the dough deflector until the kneading hook can lock into position (**Fig. 13-4b**).

- Put the ingredients to be processed into the bowl.
- Press the Release button and move the swivel arm to position 1.
- Attach the cover.
- Set the rotary switch to the desired setting.



Our recommendation:

- Stirrer: first stir in at setting 1 (1), then select setting 7 (4)
- Whisk: setting 7 (4), mix in at setting 1 (1)
- Kneading hook: first stir in at setting 1 (1), knead at setting 3 (2)

Adding more ingredients

- Switch off the appliance with the rotary switch.
- Add more ingredients through the feed tube in the cover.
 - or
 - Remove lid.
 - Press the Release button and move the swivel arm to position 2.
 - Add ingredients.



After using the appliance

- Switch off the appliance with the rotary switch.
- Pull out the mains plug.
- Remove lid.
- Press the Release button and move the swivel arm to position 2.
- Take the tool out of the drive.
- Remove the bowl.
- Clean all parts, see “Cleaning and servicing”.



Continuous-feed shredder



Risk of injury

Do not grip the sharp blades or edges of the cutting discs. Take hold of cutting discs by the edge only.

Before attaching/removing the continuous-feed shredder, wait until the drive has come to a standstill and pull out the mains plug. Do not reach into the feed tube.

Warning!

The continuous-feed shredder must be completely assembled before use. Never assemble the continuous-feed shredder on the base unit.

Operate the continuous-feed shredder in the indicated operating position only.

Predetermined breaking point Fig. 5a

The built-in predetermined breaking point protects the drive of the appliance. If an overload occurs, the drive shaft of the continuous-feed shredder breaks. However, the drive shaft can easily be replaced.

A new drive shaft with driver is available from customer service.

Reversible slicing disc – thick/thin

for slicing fruit and vegetables.

Process at setting 5 (3).

Designation on the reversible slicing disc:

“1” for the thick slicing side

“3” for the thin slicing side

Warning!

The reversible slicing disc is not suitable for slicing hard cheese, bread, rolls or chocolate. Slice boiled, waxy potatoes only when they are cold.

Reversible shredding disc – coarse/fine

for shredding vegetables, fruit cheese, except for hard cheese (e.g. Parmesan).

Processing at setting 3 (2) or 4 (3).

Designation on the reversible shredding disc:

“2” for the coarse shredding side

“4” for the fine shredding side

Warning!

The reversible shredding disc is not suitable for shredding nuts. Shred soft cheese with the coarse side only at setting 7 (4).

Grating disc – medium-fine

for grating raw potatoes, hard cheese (e.g. Parmesan), cooled chocolate and nuts.

Process at setting 7 (4).

Warning!

The grating disc is not suitable for grating soft cheese and cheese slices.

Working with the continuous-feed shredder

- Press the Release button and move the swivel arm to position **2**.
- Insert the bowl:
 - Tilt the bowl forwards and then set it down.
 - Turn anti-clockwise until it locks into place.
- Press the Release button and move the swivel arm to position **3**.



- Remove drive cover from the drive of the continuous-feed shredder (**Fig. 5a**).
- Hold drive shaft with the predetermined breaking point face down with one hand underneath.
- Carefully place the required slicing or shredding disc onto the tips of the disc holder (**Fig. 6a**). In the case of reversible discs, ensure that the required side is face up.
- Grip disc holder at the upper end and insert into the housing (**Fig. 6b**).
- Attach the cover (note mark) and turn all the way in a clockwise direction.
- Place continuous-feed shredder on the drive and rotate all the way in a clockwise direction, as illustrated in **Fig. 8**.
- Turn rotary switch to recommended setting.
- Put food to be processed in the feed tube and push down with the pusher.

Warning!

Prevent the cut ingredients from building up in the outlet opening.

Tip: To ensure evenly cut ingredients, process slender ingredients in bunches.

Note: If the food to be processed sticks in the continuous-feed shredder, switch food processor off, pull out mains plug, wait until the drive comes to a standstill, remove cover from the continuous-feed shredder and empty feed tube.

After using the appliance

- Switch off the appliance with the rotary switch.
- Rotate the continuous-feed shredder in an anti-clockwise direction and remove.
- Rotate the lid in an anti-clockwise direction and remove.
- Remove drive shaft together with disc. To do this, press finger from below against the drive shaft (**Fig. 5**).
- Clean parts.

Blender



Risk of injury from sharp blades/rotating drive!

Never place fingers in the attached blender!
Do not remove/attach the blender until the drive is at a standstill! Operate the assembled blender only and with the lid attached.



Risk of scalding!

If processing hot liquids, steam escapes through the funnel in the lid.
Add a max. 0.5 litres of hot or frothing liquid.

Warning!

Blender may be damaged. Do not process deep-frozen ingredients (except ice cubes). Do not operate when empty.

Working with the blender

Fig. 1



- Press the release button and move the swivel arm to position 4.
- Remove the blender drive cover.
- Attach blender jug (mark on the handle on mark on the base unit) and turn all the way in an anti-clockwise direction.
- Add ingredients.
Maximum capacity – liquid = 1.25 litres;
maximum capacity frothing or hot liquids max. 0.5 litres;
optimal processing capacity – solids = 50–100 g;
- Attach the cover and turn anti-clockwise all the way into the blender handle.
The lug must be engaged.
- Set the rotary switch to the desired setting.

Adding more ingredients (Fig. 1-8)

- Switch off the appliance with the rotary switch.
- Remove the cover and add ingredients or
- remove the funnel and gradually add solid ingredients through the feed tube or
- pour liquid through the funnel.

After using the appliance

- Switch off the appliance with the rotary switch.
- Rotate the blender in a clockwise direction and remove.

Tip: It is recommended to clean the blender immediately after use.

Cleaning and servicing

Attention!

Do NOT use abrasive cleaning agents. Surfaces may be damaged.

Cleaning the base unit



Risk of electric shock!

Never immerse the base unit in water or place under running water.
Do not use a steam cleaner.

- Pull out the mains plug.
- Wipe the base unit and drive cover with a damp cloth. If required, use a little detergent.
- Then dry the base unit.

Cleaning the bowl and tools

The bowl and tools are dishwasher-safe. Do not wedge plastic parts in the dishwasher, as they could be permanently deformed during the washing process!

Cleaning the continuous-feed shredder

All parts of the continuous-feed shredder are dishwasher-proof.

Tip: To remove the red film after processing e.g. carrots, pour a little cooking oil on a cloth and rub the film off the continuous-feed shredder (not the cutting discs). Then rinse the continuous-feed shredder.

Cleaning the blender



Risk of injury from sharp blades!

Do not touch blender blades with bare hands.

The blender jug, lid and funnel are dishwasher-safe.

Tip: After processing liquids, it is often sufficient to clean the blender without removing it from the appliance. Pour a little water and washing-up liquid into the attached blender.

Switch on the blender for several seconds (setting M). Pour out the water and rinse out the blender with clear water.



Important information

If required, clean accessories bag.
Follow care instructions in the bag.

Storage



Risk of injury!

When the appliance is not in use, pull out the mains plug.

Fig. 14

- Store tools and cutting discs in the accessories bag.
- Keep accessories bag in the bowl.
- To store in the original packaging, see Fig. 14.

Troubleshooting



Risk of injury!

Before eliminating a fault, pull out the mains plug.



Important information for MUM54../MUM56..

The On/Off display flashes if the appliance has been operated incorrectly or the fuse has tripped or the appliance is defective.

The swivel arm must be engaged in every operating position.

Initially try to eliminate the problem which has occurred with the help of the following information.

Fault

Appliance does not start.

Remedial action

- Check the power supply.
- Check the mains plug.
- Check swivel arm. Correct position? Engaged?
- Screw on blender or bowl as far as possible.
- Attach the blender cover and screw on as far as possible.
- Attach drive cover to unused drives.
- The safety lock is active. Switch appliance to 0/off and then back to the required setting.

Fault

Appliance switches off during use. The overload protection feature has been activated. Too much food was processed at one time.

Remedial action

- Switch off the appliance.
- Reduce processing quantity. Do not exceed permitted maximum quantities (see "Application examples").

Fault

While the drive was running, the release button was inadvertently pressed.

The swivel arm moves up. The drive switches off, but does not stop in the tool change position.

Remedial action

- Set rotary switch to **0/off**.
- Move swivel arm to position **1**.
- Switch on appliance (setting 1).
- Switch off appliance again.
- Tool stops in tool change position.

Fault

Blender does not start working or stops during use, the drive is "humming". Blade is blocked.

Remedial action

- Switch off the appliance and pull out the mains plug.
- Detach the blender and remove the obstruction.
- Re-attach the blender.
- Switch on the appliance.



Important information

If the fault cannot be eliminated, please contact customer service.

Application examples

Whipped cream

100–600 g

- Whip cream with the whisk for 1½ to 4 minutes at setting 7 (4) depending on the quantity and properties of the cream.



Egg white

1 to 8 egg whites

- Beat egg white with the whisk for 4 to 6 minutes at setting 7 (4).



Sponge mixture

Basic recipe

2 eggs

2–3 tbs. hot water

100 g sugar

1 packet of vanilla sugar

70 g flour

70 g cornflour

Baking powder if required

- Beat the ingredients (except flour and cornflour) with the whisk for approx. 4–6 minutes at setting 7 (4) until frothy.
- Rotate switch to setting 1 (1) and spoon in the sifted flour and cornflour within approx. ½ to 1 minute.

Maximum quantity: 2 x basic recipe

Cake mixture

Basic recipe

3–4 eggs

200–250 g sugar

1 pinch of salt

1 packet of vanilla sugar or peel from ½ lemon

200–250 g butter or margarine (room temperature)

500 g flour

1 packet of baking powder

125 ml milk

- Mix all ingredients with the stirrer for approx. ½ minute at setting 1 (1), then for approx. 3–4 minutes at setting 7 (4).

Maximum quantity: 1.5 x basic recipe

Short pastry

Basic recipe

125 g butter (room temperature)

100–125 g sugar

1 egg

1 pinch of salt

A little lemon peel or vanilla sugar

250 g flour

Baking powder if required

- Using the stirrer, process all ingredients for approx. ½ minute at setting 1 (1), then for approx. 2–3 minutes at setting 6 (3).

From 500 g flour:

- Knead the ingredients with the kneading hook for approx. ½ minute at setting 1 (1), then for approx. 3–4 minutes at setting 3 (2).

Maximum quantity: 2 x basic recipe



Yeast dough

Basic recipe

500 g flour

1 egg

80 g fat (room temperature)

80 g sugar

200–250 ml lukewarm milk

25 g fresh yeast or 1 packet of dried yeast

Peel of ½ lemon

1 pinch of salt

- Mix all ingredients with the kneading hook for approx. ½ minute at setting 1, then for approx. 3–6 minutes at setting 3 (2).

Maximum quantity: 1.5 x basic recipe



Pasta dough

Basic recipe

300 g flour

3 eggs

1–2 tbs. (10–20 g) cold water as required

- Process all ingredients for approx. 3–5 minutes at setting 3 (2) until a dough forms.

Maximum quantity: 1.5 x basic recipe



Mayonnaise

2 eggs

2 tsp. mustard

¼ l oil

2 tbs. lemon juice or vinegar

1 pinch of salt

1 pinch of sugar

Ingredients must be at the same temperature.

- Process the ingredients (except the oil) in the blender for several seconds at setting 3 (2) or 4 (3).
- Switch the blender to setting 7 (4) and slowly pour the oil through the funnel and mix until the mayonnaise emulsifies.

Eat the mayonnaise immediately, do NOT store.



Honey bread spread

30 g butter (from refrigerator, 7 °C)

190 g honey (from refrigerator, 7 °C)

- Cut butter into small pieces and put into the blender.
- Add honey and blend for 15 seconds at setting 7 (4).



Disposal



This appliance has been identified in accordance with the European directive 2012/19/EG on Waste Electrical and Electronic Equipment – WEEE. The Directive paves the way for effective EU-wide withdrawal and utilization of waste appliances.

Please ask your dealer or inquire at your local authority about current means of disposal.







Warranty conditions

The guarantee conditions for this appliance are as defined by our representative in the country in which it is sold. Details regarding these conditions can be obtained from the dealer from whom the appliance was purchased.

The bill of sale or receipt must be produced when making any claim under the terms of this guarantee.

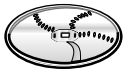
Optional accessories

	<p>MUZ5ZP1 Citrus press</p>	<p>For squeezing oranges, lemons and grapefruits.</p>
	<p>MUZ5CC1 Dicer</p>	<p>For cutting fruit and vegetables into equally sized cubes.</p>
	<p>MUZ5FW1 Mincer</p>	<p>For cutting fresh meat for steak tartare or meat loaf.</p>
	<p>MUZ45LS1 Perforated disc set fine (3 mm), coarse (6 mm)</p>	<p>For the mincer MUZ5FW1. Fine disc for pasties and spreads, coarse disc for sausages and bacon.</p>
	<p>MUZ45SV1 Viennese whirl attachment</p>	<p>For the mincer MUZ5FW1. With metal template for 4 different pastry moulds.</p>
	<p>MUZ45RV1 Grater attachment</p>	<p>For the mincer MUZ5FW1. For grating nuts, almonds, chocolate and dried bread rolls.</p>
	<p>MUZ45FV1 Juicer attachment</p>	<p>For the mincer MUZ5FW1. For pressing soft fruit, except raspberries, tomatoes and rose hips, to a pulp. At the same time e.g. currants are automatically stemmed and pitted.</p>

	MUZ45PS1 Chipper disc	For the continuous-feed shredder MUZ5DS1. For slicing raw potatoes for chips.
	MUZ45AG1 Asiatic vegetables disc	For the continuous-feed shredder MUZ5DS1. Slices fruit and vegetables into fine strips for Asian vegetable dishes.
	MUZ45RS1 Grating disc coarse	For the continuous-feed shredder MUZ5DS1. For grating raw potatoes, e.g. for potato pancakes or dumplings.
	MUZ45KP1 Potato fritter disc	For the continuous-feed shredder MUZ5DS1. For grating raw potatoes for rostis and potato fritters, for cutting fruit and vegetables into thick slices.
	MUZ5ER2 Stainless steel stirring bowl	Up to 750 g of flour plus ingredients can be processed in the bowl.
	MUZ5KR1 Plastic mixing bowl	Up to 750 g of flour plus ingredients can be processed in the bowl.
	MUZ5MX1 Plastic blender attachment	For blending drinks, for pureeing fruit and vegetables, for preparing mayonnaise, for cutting fruit, nuts, for crushing ice cubes.
	MUZ5MM1 Multi-blender	For chopping herbs, vegetables, apples and meat, for shredding carrots, radishes and cheese, for grating nuts and cooled chocolate.

If an accessory is not included in the product package, it can be purchased via the trade or customer service.

* Not all accessories available in Australia.

Subject to alterations.

Robert Bosch Hausgeräte GmbH

Carl-Wery-Str. 34

81739 München

Germany

www.bosch-home.com

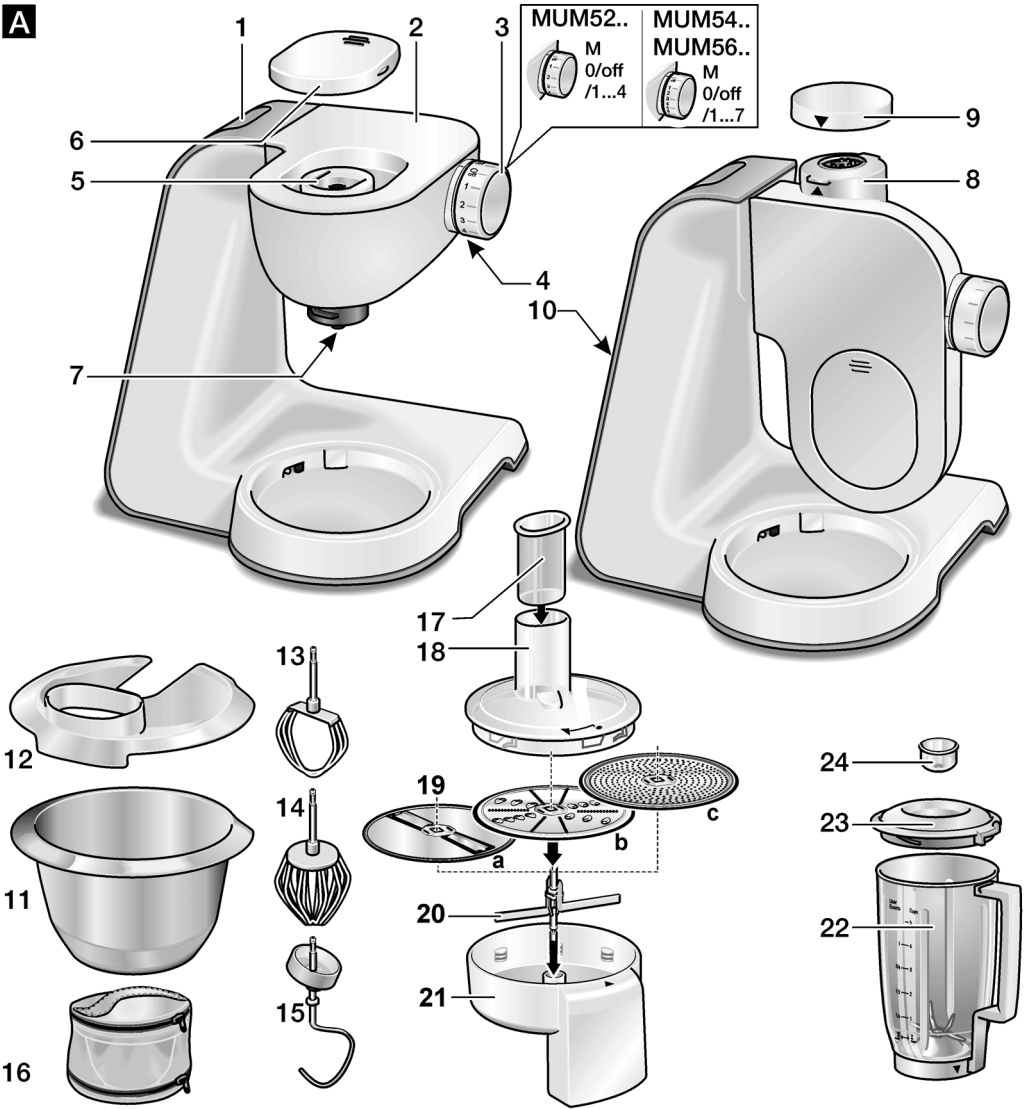
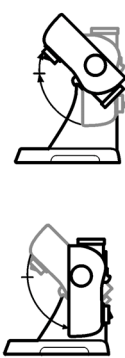
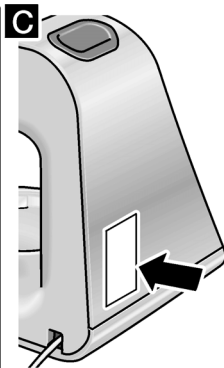
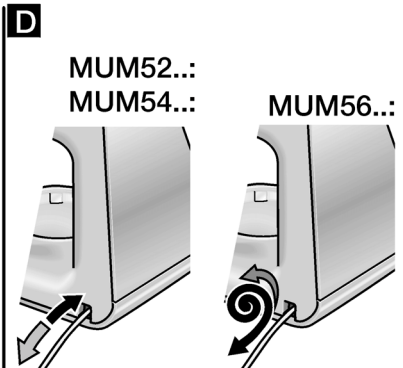
A**B****C****D**

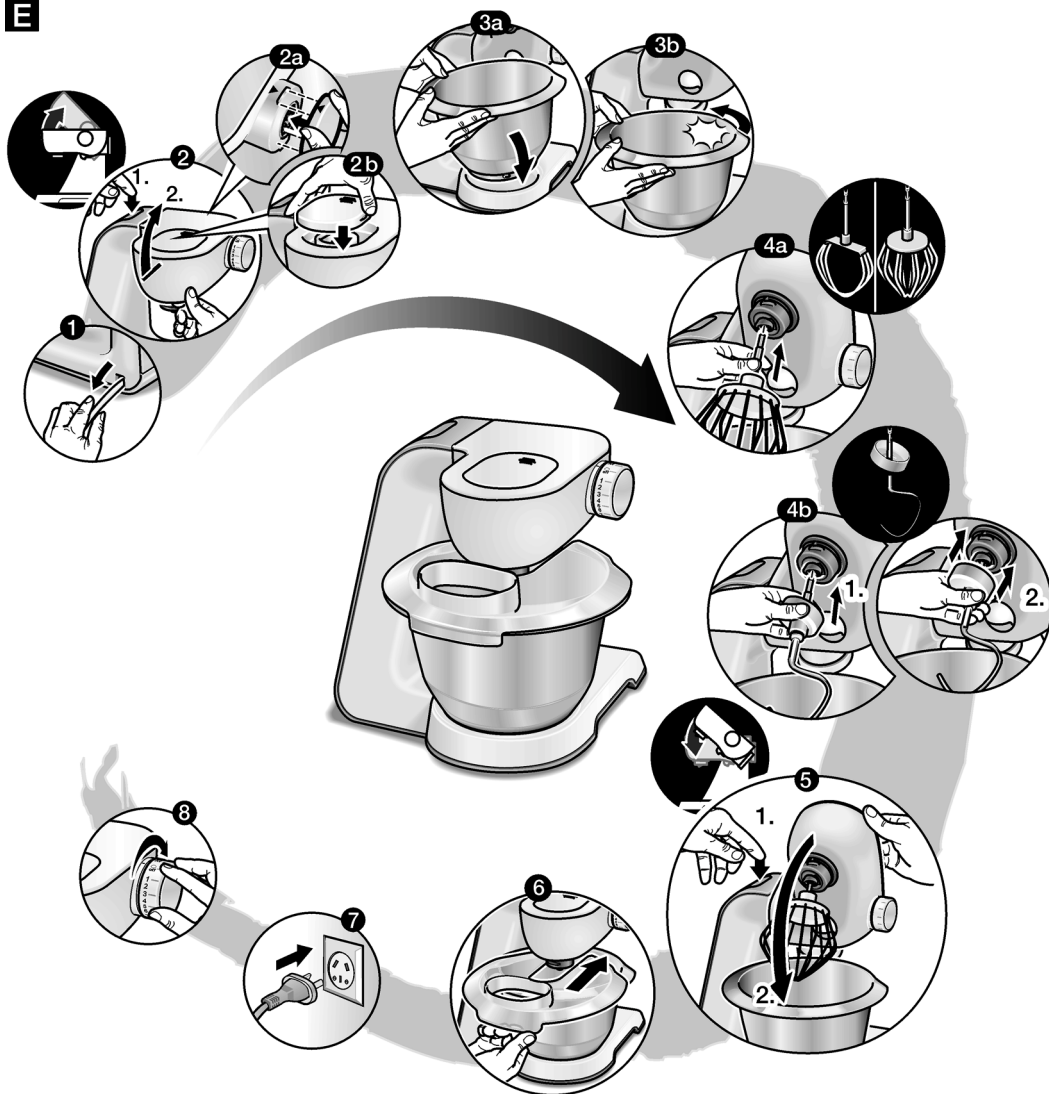
E

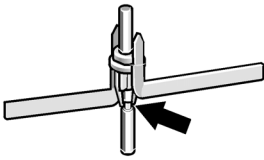
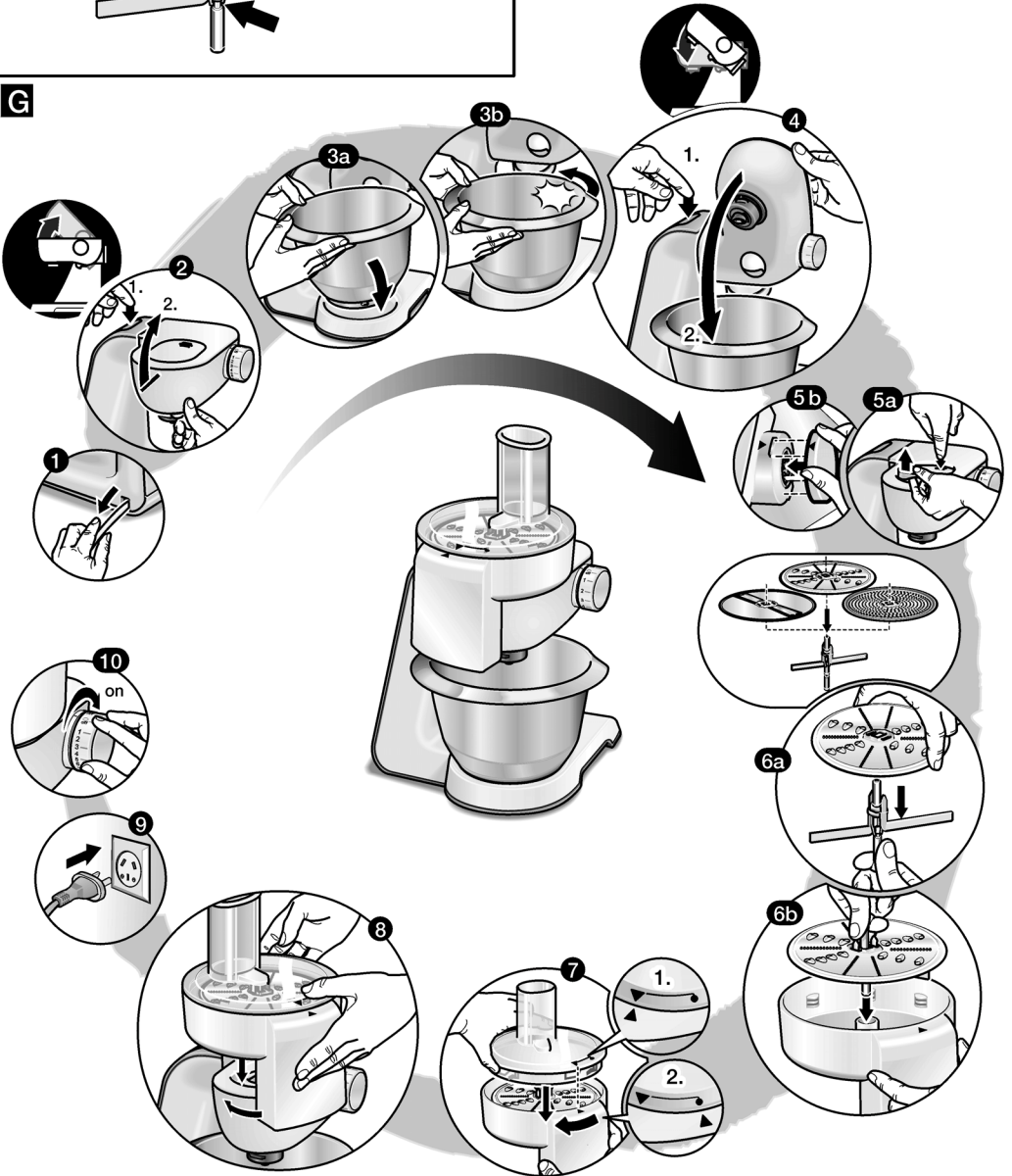
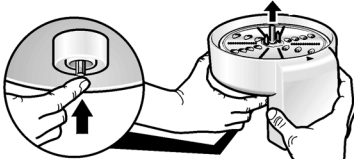
F**G****H**

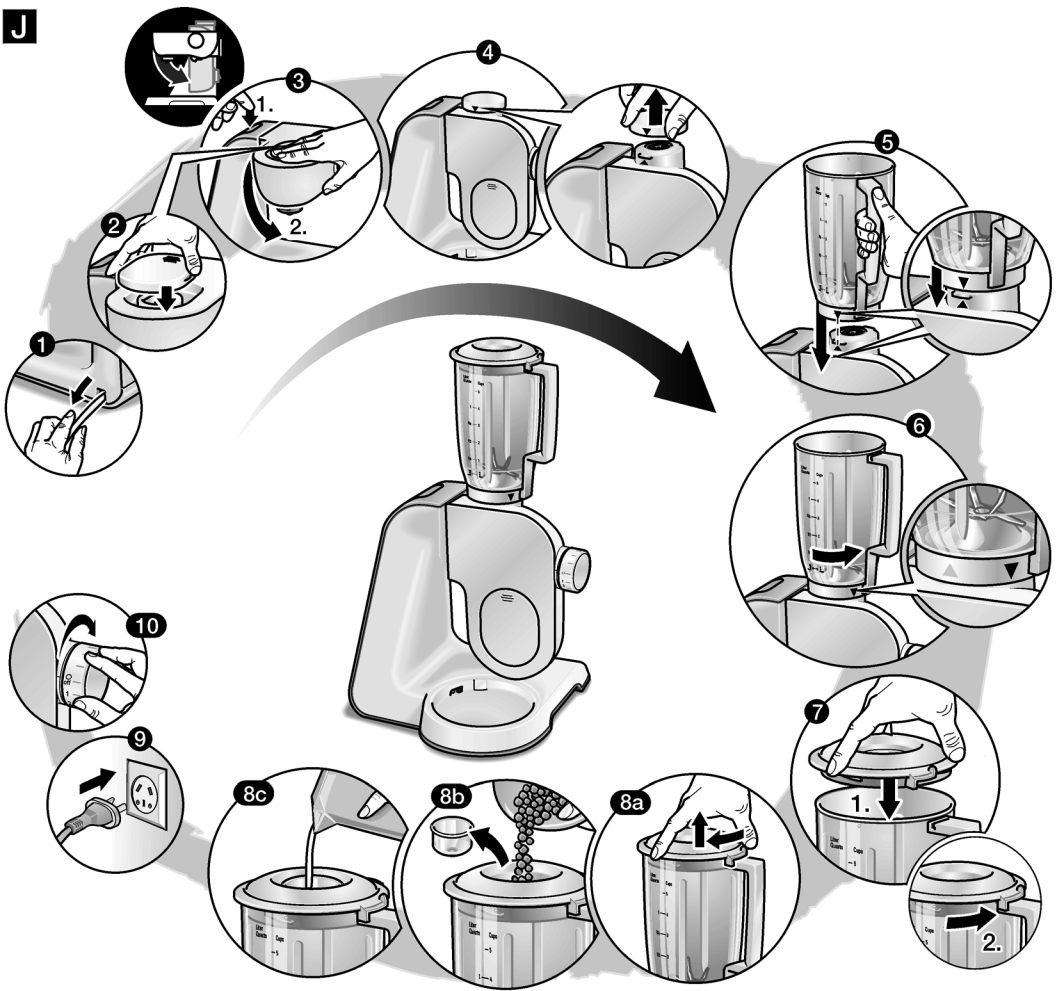
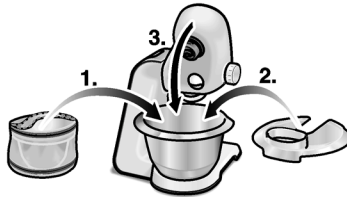
J**K****L**